



Director of  
Central  
Intelligence

~~Secret~~

# Soviet Ballistic Missile Defense

National Intelligence Estimate  
Volume I—Key Judgments and Summary

**CIA HISTORICAL REVIEW PROGRAM  
RELEASE AS SANITIZED**

~~Secret~~

NIE 11-13-82  
13 October 1982

Copy

21



THIS ESTIMATE IS ISSUED BY THE DIRECTOR OF CENTRAL INTELLIGENCE.

THE NATIONAL FOREIGN INTELLIGENCE BOARD CONCURS, EXCEPT AS NOTED IN THE TEXT.

*The following intelligence organizations participated in the preparation of the Estimate:*

The Central Intelligence Agency, the Defense Intelligence Agency, the National Security Agency, and the intelligence organizations of the Departments of State and Energy.

*Also Participating:*

The Assistant Chief of Staff for Intelligence, Department of the Army

The Director of Naval Intelligence, Department of the Navy

The Assistant Chief of Staff, Intelligence, Department of the Air Force

The Director of Intelligence, Headquarters, Marine Corps

~~SECRET~~

NIE 11-13-82

SOVIET BALLISTIC MISSILE DEFENSE

Volume I—Key Judgments and Summary

Information available as of 13 October 1982 was  
used in the preparation of this Estimate.

~~SECRET~~

## CONTENTS

	<i>Page</i>
PURPOSE AND SCOPE.....	1
KEY JUDGMENTS.....	3
SUMMARY.....	7
I. Factors Affecting Future Soviet Ballistic Missile Defenses.....	7
Military Doctrine and Strategy.....	7
Soviet ABM Programs—Historical Perspective.....	7
Military Factors.....	8
Political Factors.....	9
Capabilities of Soviet Systems for Ballistic Missile Defense.....	10
The Moscow System.....	10
New ABM Systems.....	10
Surface-to-Air Missile Systems.....	14
Capabilities for ABM Deployments.....	16
Upgraded ABM Defenses at Moscow.....	16
Options for Deployments Beyond Treaty Limits.....	16
Radars for Battle Management Support.....	19
Potential ABM Deployment Rates.....	22
Indications of Postulated ABM Deployments.....	22
Economic Factors.....	24
II. Prospects for Directed-Energy Weapons.....	24
Laser Systems.....	26
Ground-Based.....	26
Space-Based.....	26
Particle Beam Weapons.....	26
Ground-Based.....	26
Space-Based.....	26
III. Capabilities of Soviet Ballistic Missile Defenses.....	27
Upgraded Moscow Defenses Within Treaty Limits.....	27
Expanded Defenses at Moscow.....	27
Widespread ABM Defense.....	27
IV. Future Soviet ABM Deployments.....	28
Revisions to the ABM Treaty.....	28
US Withdrawal From the Treaty.....	29
Soviet Abrogation of the Treaty.....	29
V. Key Uncertainties.....	32

## PURPOSE AND SCOPE

This Estimate responds to a request of the President's Special Assistant for National Security Affairs for a comprehensive assessment by the Intelligence Community on Soviet antiballistic missile (ABM) defense. It has been prepared for use by the administration in considering strategic arms limitation policies, in planning US strategic force programs, and in reviewing the ABM Treaty. It is intended to provide our best answers to the following questions relevant to US policy and planning decisions:

- What are the objectives of Soviet programs for ballistic missile defense?
- What are the estimated technical characteristics and performance of present and future Soviet ballistic missile defense systems and supporting radars?
- What potential do the Soviets have to deploy ballistic missile defenses beyond the limits of the ABM Treaty during the next 10 years or so?
- What is the likelihood that the Soviets will deploy ballistic missile defenses in excess of Treaty limits?

While the Estimate highlights factors bearing on the effectiveness of Soviet ballistic missile defenses it does not analyze in any detail the degree of protection that future ABM deployments would afford the USSR. We have not performed the analyses of the capabilities of Soviet ABM systems in a multiple-engagement scenario. The great complexity and severe time constraints inherent in ballistic missile defense operations result in our having major uncertainties in any prediction of how well a Soviet ABM system would function. Any assessment of Soviet ABM effectiveness will be an aggregation of the results of technical analyses of expected component performance using assumptions about the characteristics of a ballistic missile attack, about some nuclear weapon effects, and about the phenomena associated with ballistic missiles reentering the atmosphere.

Given the gaps in information and our analytical uncertainties, there are understandably many differing conclusions and opinions about the technical characteristics of Soviet ABM systems and components and supporting radars and about their capabilities to perform all

the functions essential to ballistic missile defense. Some of these differences concern capabilities on which the success or failure of a future Soviet ballistic missile defense would depend. We are not likely to be able to resolve many of these issues within the next several years. Moreover, we have difficulty assigning probabilities to alternative interpretations of the evidence. However, the consequences of Soviet acquisition of a ballistic missile defense, despite uncertainties about its effectiveness, are so serious that even a low probability of such an achievement is cause for concern.

Volume II of this Estimate, "The Analysis," treats Soviet ballistic missile defense programs in the detail required by staff planners and analysts responsible for policy studies and military assessments. Its emphasis is on completeness rather than brevity. The important findings of the Estimate on the prospects for future Soviet ballistic missile defense are summarized in volume I.

## KEY JUDGMENTS

The Soviets are upgrading their antiballistic missile (ABM) deployments at Moscow and are actively engaged in ABM research and development programs. The available evidence does not indicate with any certainty whether the Soviets are making preparations for deployments beyond the limits of the Treaty—100 ABM launchers at Moscow—but it does show they are steadily improving their ability to exercise options for deployment of widespread ballistic missile defenses in the 1980s. If the Treaty were abrogated by either the United States or the USSR, we believe the Soviets would undertake rapidly paced ABM deployments to strengthen their defenses at Moscow and cover key targets in the western USSR, and to extend protection to key targets east of the Urals. Such widespread defenses could be in place by the late 1980s or early 1990s.

Since the negotiation of the ABM Treaty in 1972, most of the trends in strategic forces have been favorable to the USSR. The Soviets probably consider that they are much better able to prosecute a nuclear war than they were in 1972. To reduce damage to the USSR in accordance with their doctrine and strategy for nuclear war, the Soviets are continuing to improve the counterforce capabilities and survivability of their offensive forces, to strengthen their air defenses and antisubmarine warfare forces, and to expand their passive defenses. In this context, we believe that an assessment by the Soviets of the correlation of strategic forces would indicate that the continuing vulnerability of the USSR to ballistic missile attack is a deficiency they would want to reduce.

We judge that in evaluating the technical performance of the ABM systems they could deploy, the Soviets probably would not have high confidence in how well these systems would perform against a large-scale, undegraded US missile attack, especially in the late 1980s by improved US forces. However, the Soviets would probably view their ballistic missile defenses as having considerable value in reducing the impact of a degraded US retaliatory attack if the USSR succeeded in carrying out a well-coordinated, effective initial strike. Also, widespread Soviet defenses, even if US evaluations indicated they could be overcome by an attacking force, would complicate US attack planning and create major uncertainties about the potential effectiveness of a US strike.



Another view is that the Soviets, in a widespread deployment, would deploy sufficient numbers of ABM systems to enhance their confidence in the survival of high-value targets, even in the event of a full-scale US attack.<sup>1</sup>

If certain features which we have assumed for a new advanced surface-to-air missile (SAM) system, the SA-X-12, are realized, its potential contribution to ballistic missile defenses would be of growing concern as it becomes widely deployed in the USSR and Eastern Europe in the mid-to-late 1980s. While we do not believe the SA-5 and SA-10 SAM systems are suitable for ABM use as currently configured, the Soviets could, with an unrestricted modification and testing program, probably conduct an overt upgrade of these systems that would provide a potentially important supplement to an ABM defense. There is an alternative view that the SA-5 and SA-10 without any upgrading may be capable of operating in a limited ABM role, and that [ ] upgrade to improve potential ABM capabilities could be performed [ ]<sup>2</sup>

A decision by the Soviets on whether to deploy a widespread ABM system would be based primarily on the answer to a crucial question: whether the USSR will face a sufficiently threatening strategic situation in the late 1980s and beyond, for which an expanded ABM defense based on their systems now in testing and development would make a significant difference. If their answer is yes, then they would probably make the commitments necessary to deploy such defenses despite the economic and political costs. Since their answer probably will not be clear-cut, other important factors would bias their decision toward nondeployment:

- The USSR's two-track approach—arms control and a military buildup—to further its strategic goals has achieved limits on US delivery vehicles and constrained US defenses, while permitting expansion of Soviet offensive forces. There are no indications that the USSR is becoming dissatisfied with this approach.
- Under the Treaty the USSR has ABM defenses to protect critical targets in the Moscow area while the United States has no similar capability.
- The Soviets apparently see the Treaty as having slowed US ABM research and development, while they moved ahead with their own.

<sup>1</sup> The holder of this view is the Director, Defense Intelligence Agency.

<sup>2</sup> The holder of this view is the Director, Defense Intelligence Agency.

On balance, we believe there is a fairly low, but nevertheless significant chance (about 10 to 30 percent) that the Soviets will abrogate the Treaty and deploy ABMs in excess of Treaty limits in the 1980s. We believe they would see the military advantages of the defenses they could deploy as being outweighed by the disadvantages cited above, especially of energizing the United States and perhaps its Allies into a rapid and sustained growth in overall military capabilities, both conventional and nuclear, that could lead to an erosion in the 1990s of Soviet gains achieved in the 1970s and 1980s.

An alternative view notes that Soviet benefits from the Treaty, under current and projected conditions, far outweigh the potential gains from abrogation. As a result, the likelihood of abrogation is considered to be very low (10 percent or less) in the 1980s unless current conditions change substantially. This view cautions, however, that the Soviets have a motivation to deploy a widespread ABM system to fill the serious gap in their defenses, and there is a higher probability of such a deployment in the 1990s. Moreover, they have the capability to complete such a deployment in only a few years.<sup>3</sup>

Another view holds that the crucial question for Soviet leaders is whether deployment of ABMs is required to attain Soviet strategic objectives. According to this view, the following factors should be given greater weight in judging Soviet motivations for deployment of a widespread ABM defense. Soviet doctrinal requirements for damage-limiting capability have always provided the motivation to deploy ABMs both at Moscow and elsewhere. Now, as a result of advances by the USSR in ABM technology, the USSR's counterforce advantage over the United States, and US plans to deploy survivable and hard-target-capable ballistic missiles, the Soviets may no longer deem it necessary to restrain themselves from further ABM deployment. They have taken essentially all the steps necessary to prepare for a decision to deploy and have demonstrated confidence in their current ABM technology by deploying the new ABM system at Moscow. The Soviets may be expected to accompany any widespread ABM deployments with an active-measures campaign to manipulate Western attitudes and actions and to inhibit energizing the United States and its Allies into sustaining a rapid growth in military capabilities. The holder of this view believes it is not possible with current intelligence data to evaluate and quantify with confidence the extent to which various factors would influence the Soviets to abandon or retain the ABM Treaty. However, given the preparations the Soviets have made and the fact that the motivations

<sup>3</sup> The holder of this view is the Assistant Chief of Staff for Intelligence, Department of the Army.

discussed above strongly influence Soviet decisions, the main text may have understated the prospect for widespread ABM deployment.<sup>4</sup>

□

□ A widespread Soviet ABM deployment by the late 1980s or early 1990s would give the USSR an important initial advantage over the United States in this area. We have major uncertainties about how well a Soviet ABM system would function, and the degree of protection that future ABM deployments would afford the USSR. Despite our uncertainties about its potential effectiveness, such a deployment would have an important effect on the perceptions, and perhaps the reality, of the US-Soviet strategic nuclear relationship. According to an alternative view, the Soviet Union will not have the capability in this decade to deploy ABM defenses which would significantly affect the US-Soviet strategic nuclear relationship.<sup>5</sup>

<sup>4</sup> The holder of this view is the Director, Defense Intelligence Agency.

<sup>5</sup> The holder of this view is the Director, Bureau of Intelligence and Research, Department of State.

## SUMMARY

1. The Soviets' antiballistic missile (ABM) programs would enable them to have deployed by the late 1980s to early 1990s widespread<sup>1</sup> ballistic missile defenses that would have an important effect on the perceptions and perhaps the reality of the US-Soviet strategic nuclear relationship. Other means envisioned by the Soviets for reducing potential damage to the USSR from ballistic missiles—not assessed in this Estimate—include Soviet counterforce strikes on enemy ballistic missiles and facilities for their control, attacks on ballistic missile submarines by Soviet antisubmarine warfare (ASW) forces, hardening and mobility of Soviet military forces, and passive defense measures. We believe the Soviets regard ABM as a critical element in their future capability to reduce damage from a US ballistic missile attack.

2. The available evidence does not indicate with any certainty whether the Soviets are making preparations for ABM deployments beyond the limits of the ABM Treaty, but it does show that, through their ABM development and deployment programs, the Soviets are steadily improving their ability to exercise options for widespread ballistic missile defenses. In making any decision to deploy ABMs in excess of Treaty limits, we believe Soviet leaders would give first consideration to the net effect of ABM deployments on their capability to perform the missions called for by Soviet strategy, taking into account likely US strategic offensive and defensive force deployments. They would also consider other factors such as the overall military, political, and economic implications of revising, abrogating, or withdrawing from the ABM Treaty.

### I. FACTORS AFFECTING FUTURE SOVIET BALLISTIC MISSILE DEFENSES

#### Military Doctrine and Strategy

3. The Soviets' present military doctrine and strategy emphasize offensive operations to neutralize or

<sup>1</sup> A widespread defense, in the western USSR or nationwide, would be one deployed to protect key military, leadership, and military industrial targets. Although we employ the terms "widespread" and "nationwide" in the text, it should be noted that many areas of lesser importance might not be protected by ABM coverage.

eliminate US nuclear forces and reject mutual vulnerability as a desirable or permanent basis for the US-Soviet strategic relationship. The Soviets prefer superior capabilities to fight and win a nuclear war with the United States, and have been working to improve their chances of prevailing in such a conflict.

4. We have no reason to expect any major alterations in Soviet doctrine and strategy during the 1980s and beyond. It is likely that in the future the Soviets will of necessity be unable to rely as heavily on offensive forces to destroy US strategic nuclear delivery means. They are clearly aware that US strategic force modernization programs will make more difficult and less certain the future effectiveness of counterforce strikes by the USSR. At the same time, the Soviets are continuing to take measures to reduce the vulnerability of their own strategic offensive forces as they recognize that fixed-base weapons are becoming increasingly vulnerable. They will not view these trends as requiring them to reduce the offensive, counterforce orientation of their strategy in favor of some assured level of survivability, as would be implied by a defense-dominated strategy. Rather, they will see the situation as placing a greater burden on active and passive defenses to achieve their strategic objectives.

5. Changes in the future capabilities of Soviet strategic defenses could have a greater effect on the US-Soviet strategic relationship than at any time in the past, particularly if there were major reductions in offensive missiles of the two sides under a new arms agreement. Thus, from the standpoint of the objectives called for by their doctrine and strategy, the Soviets may have greater incentives in the 1980s and 1990s to acquire a credible ballistic missile defense.

#### Soviet ABM Programs—Historical Perspective

6. The Soviets apparently formalized programs for defenses against ballistic missiles early in the 1950s, but our understanding of some of these early programs is quite limited and subject to interpretation. Since the 1950s, they have devoted considerable resources to ballistic missile defense and have started deployment

of ABM systems before developmental testing was completed. There are differing assessments about whether the history of Soviet ABM research, development, and deployments indicates two distinct overall programs—one for defenses at Moscow and another for a widespread defense—or whether the Soviets have been pursuing a single program with several potential applications. The question of whether they have been pursuing a single or dual ABM program has little bearing on key issues of the technical performance and effectiveness of the ABM systems and components under development and the USSR's capabilities to deploy them. According to one view, however, the continuation of two programs in parallel is indicative of Soviet commitment to ABM and implies the Soviets may intend to deploy defenses beyond Moscow.<sup>2</sup>

#### Military Factors

7. The Soviets negotiated the SALT I agreements to achieve political and military objectives that they believed could not be attained by unconstrained development and deployment of strategic weapons. From their perspective in 1972, the Soviets expected the ABM Treaty to enhance their counterforce capabilities by inhibiting the United States from deploying an extensive ballistic missile defense of Minuteman. At the same time, they probably assessed that their own ABM systems then under development would be unable to protect critical targets from US missile attacks at least through the 1970s. They hoped to continue their own ABM development programs while inducing the United States to slow down. A key issue is how the Soviets now assess the effect of a continuation of the ABM Treaty limitations on the present and future relationship of US and Soviet military power.

8. Since the negotiation of the ABM Treaty, most of the trends in strategic forces have been favorable to the USSR. The Soviets probably consider that they are much better able to prosecute a nuclear war than they were in 1972. To reduce damage to the USSR in accordance with their doctrine and strategy for nuclear war, the Soviets are continuing to improve the counterforce capabilities and survivability of their offensive forces, to strengthen their air defenses and antisubmarine warfare forces, and to expand their

<sup>2</sup> The holders of this view are the Director, Defense Intelligence Agency, and the Assistant Chief of Staff for Intelligence, Department of the Army.

passive defenses. In this context, we believe that a Soviet assessment of the correlation of strategic forces would indicate that the continuing vulnerability of the USSR to ballistic missile attack is an obvious deficiency that should be redressed; however, various political and economic factors as well as military requirements would figure in any Soviet decision to deploy ABMs in excess of the Treaty limits.

9. There is an additional view that to appreciate the military factors affecting Soviet attitudes toward ABMs one should consider the totality of the Soviets' commitment to a strategic war-fighting capability, as exemplified by their continued reliance on the damage-limiting forces and measures cited in the preceding paragraph. Their doctrinal requirement for victory in a nuclear war dictates acquisition of *all* military forces needed to achieve that objective, including ABMs.<sup>3</sup>

10. Developments in military technology in the 1980s that could increase the Soviets' incentive for extensive deployment of ballistic missile defenses in the 1990s include advances in ABM technology that resulted in a significant increase in system effectiveness and development of survivable radars that could contribute to a hard-point ABM defense of ICBM fields. Other technical advances by the United States, however, such as the development of maneuvering reentry vehicles (MaRVs)—evader MaRVs suitable for use against hard targets—could reduce Soviet incentives to undertake widespread deployment of ABM systems now being developed.

11. An additional view holds that US countermeasures provide additional incentives for the Soviets to improve the capabilities of their ABM systems; however, prospects for US countermeasures would have little effect on Soviet incentives for undertaking widespread ABM deployments.<sup>4</sup>

12. Their increasing vulnerability to a ballistic missile attack could influence the Soviets to expand their ABM programs. The growing size and sophistication of French, British, and Chinese ballistic missiles, and the deployment of Pershing II would be taken into account by the Soviets. Most important, of course, the US

<sup>3</sup> The holders of this view are the Director, Defense Intelligence Agency, and the Assistant Chief of Staff for Intelligence, Department of the Army.

<sup>4</sup> The holder of this view is the Director, Defense Intelligence Agency.

MX and Trident programs would, later in the 1980s, confront the Soviets with much improved hard-target threats.

#### Political Factors

13. A decision on whether to deploy a widespread ABM system would be made by the top Soviet leadership, based primarily on military rather than political or economic factors. The crucial question for the Soviet leaders is whether the USSR will face a qualitatively different and sufficiently threatening strategic situation in the late 1980s and beyond, for which they would perceive that a widespread ABM system would make a significant difference. If their answer is yes, then the Soviets would probably make the commitments necessary to deploy such a system and would accompany the deployment with a propaganda blitz to minimize short-term political losses. The answer, however, probably will not be clear-cut to Soviet leaders and important factors would bias their decision toward nondeployment:

- The primary factor is the continued effectiveness of the method the USSR developed in the early 1970s to further its strategic goals. In essence, this method has been a two-track approach calling for arms control and a Soviet military buildup. During the 1970s the USSR achieved limits on the number of US delivery vehicles through the SALT process, constrained US defenses through the ABM Treaty, and gave priority to building up its own offensive forces. This two-track approach worked well in the 1970s, and there are no indications that the USSR is becoming dissatisfied with it.
- A second factor is the advantage the USSR currently enjoys by virtue of the ABM defenses to protect critical targets in the Moscow area, even though these defenses will remain limited under the ABM Treaty. In contrast, the United States has no similar capability. Also the Soviets apparently see the Treaty as having slowed US ABM research and development, while they moved ahead with their own. They would not lightly forgo these advantages and risk stimulating US ABM development and deployment programs.
- A third factor is the significant resource commitment for such a system, which would have to be

weighed in the resource-constrained environment of the 1980s. Allocation of these resources to ABM would probably affect some other military programs, rather than simply add to the annual growth that has gone into defense spending.

- A fourth factor is the absence of strong leadership at the center. There is already a lack of clear direction under the Brezhnev regime. The rebuilding of new power and personal relationships in the aftermath of Brezhnev's departure are not circumstances conducive to making the tough decision to initiate a widespread ABM deployment within at least the next several years. There is an alternative view that by the time critical decisions would have to be made on ABM deployment—not expected before the 1990s, according to this view—the succession process is likely to be complete. It is unlikely, therefore, that the absence of strong leadership will bear significantly on Soviet ABM programs in the near term.<sup>a</sup>

- The effects of a positive ABM decision on the relationship with the United States and Western Europe would be counted on the negative side, but if the Soviets felt compelled to deploy a widespread ABM system, this factor would probably not hold them back. The leadership would assume that the West would attempt to adjust to the fact that the USSR was developing substantial ABM defenses, but the Soviets would stress the defensive nature of the system and try to use Western public opinion to constrain the freedom of action of Western governments.

14. An alternative view stresses that the crucial question for Soviet leaders is whether deployment of an active ABM defense is required to attain Soviet strategic objectives. In addressing this question, the Soviets would consider the value of such deployment in the context of the totality of their strategic military posture, which includes a broad range of damage-limiting forces and tactics. The factors that are listed above would also certainly affect Soviet judgment, but not necessarily toward the negative:

- While the Soviets have every justification for being satisfied with their two-track approach of

<sup>a</sup> The holder of this view is the Assistant Chief of Staff for Intelligence, Department of the Army.

arms control and military buildup, there are factors that may convince them that this approach with regard to ABMs has served out most of its useful life. These include the present level of the Soviets' ABM technology, their current ICBM counterforce advantage, and the planned US deployment of survivable hard-target-capable strategic ballistic missiles.

- While the ABM defense equation is one-sided in the Soviet favor, it is not clear that the Soviets believe that further ABM deployments would precipitate US offensive or defensive deployments substantial enough to offset the benefits of their own ABM deployments. The Soviets would undoubtedly undertake active measures to manipulate Western opinion and lessen such US reactions.
- This view points out that consistency and continuity of party control of military doctrine and derived programs have been a hallmark of Soviet military development and deployment. The deployment of widespread ABM defenses, a fundamental doctrinal requirement, involves decisions over such an extended period of time that it is unlikely to be affected by leadership changes.
- The Soviets could assess the increase in their overall strategic strength that could result from such a deployment as adding significantly to their influence in Western Europe.<sup>6</sup>

#### Capabilities of Soviet Systems for Ballistic Missile Defense

15. The Soviets' assessment of the capability of the ABM systems and components they are developing is a key factor bearing on their policies and programs for ballistic missile defense. We do not know how they assess these capabilities. In our own assessments, there are uncertainties and differences of view among intelligence agencies about some of the capabilities of individual Soviet ABM systems and the potential of some Soviet surface-to-air missiles (SAMs) to perform in an ABM role. We have been unable to assess in any detail the degree of protection from ballistic missile attack that the Soviets could achieve by deployment of the ABM systems and components they have under development.

<sup>6</sup> The holder of this view is the Director, Defense Intelligence Agency.

#### The Moscow System

16. The present ballistic missile defenses at Moscow consist of four sites with aboveground launchers and engagement radars, and the large radars—designated Dog House and Cat House—to provide target acquisition and tracking data. (See figure 1.) These defenses—now being upgraded—could provide only a limited, single-layer defense; that is, they could intercept ballistic missile reentry vehicles (RVs) only outside the atmosphere. These defenses probably could counter a small attack not accompanied by penetration aids such as chaff and decoys. Attempting to counter a larger number of attacking RVs, however, would rapidly exhaust the available interceptors.

#### New ABM Systems

17. We believe that the upgraded defenses at Moscow and any additional ballistic missile defenses the Soviets may deploy in the 1980s will incorporate components currently under development. Of these, the upgraded defenses at Moscow will apparently include a new large fixed engagement radar which may have capabilities for search and target acquisition; silo launchers; a high-acceleration, short-range interceptor; and a modified version of the exoatmospheric interceptor deployed with the original defenses at Moscow. The rapidly deployable system the Soviets are developing—a site for which could be deployed in months rather than years—would consist of transportable engagement radars, aboveground launchers, and either a long-range interceptor or a high-acceleration, short-range interceptor or both.

18. There are major uncertainties and gaps in information about key performance parameters of the components of ABM systems the Soviets are developing and deploying. Agencies differ in their analyses and in engineering judgments about these key parameters and, as a result, reach different conclusions about the capabilities of Soviet systems to intercept US ballistic missile reentry vehicles. These capabilities would vary, depending on various factors—for example, whether target acquisition and tracking data (handover data) were provided to the ABM launch site from a remotely located radar providing battle management support.

19. The characteristics of Soviet ABM components that have the greatest impact on assessments of their effectiveness, based on evidence of test activity, include the search and target discrimination capabilities

Figure 1  
The Moscow Antiballistic Missile System

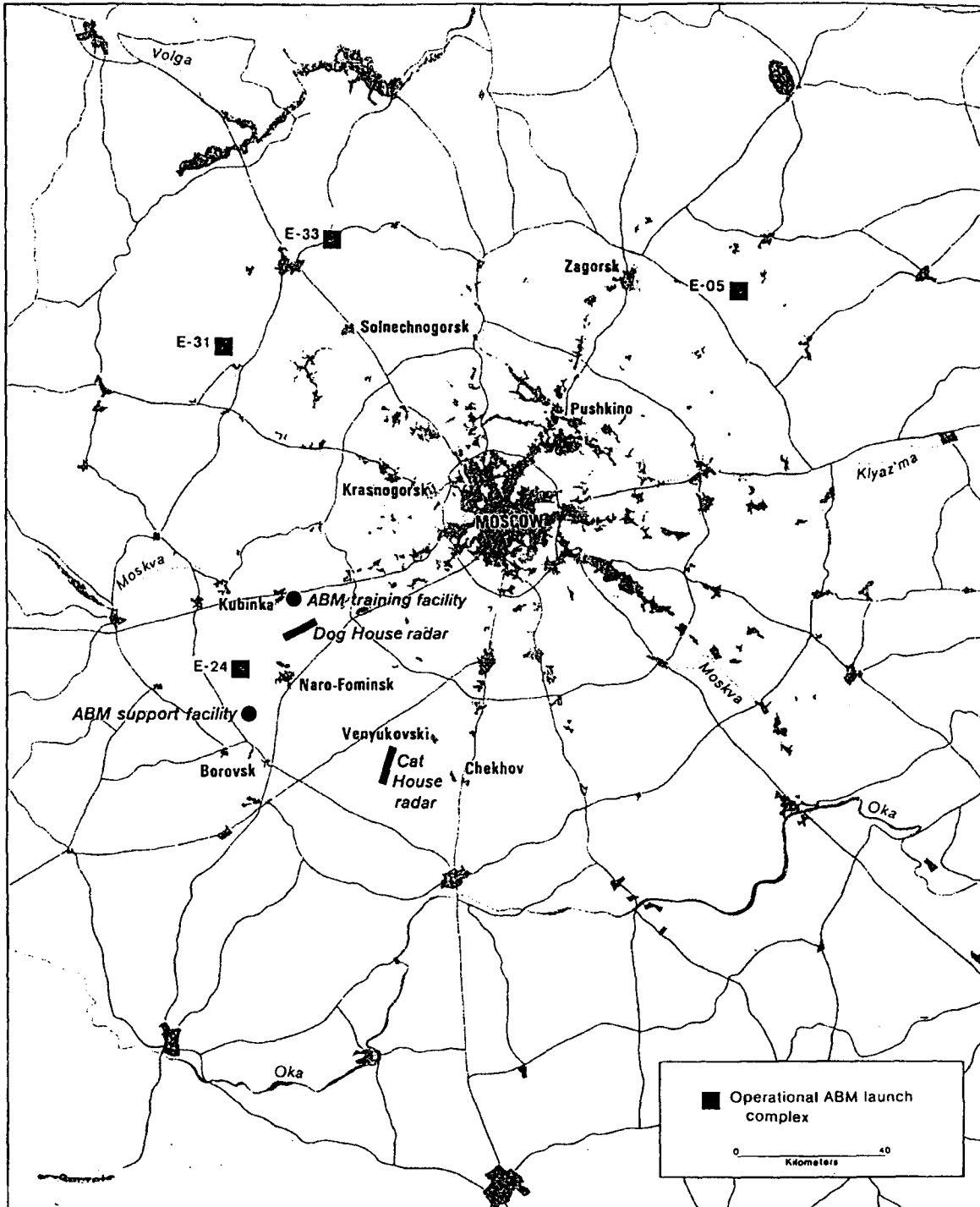

637600 9-87



of engagement radars, the target-handling capabilities of all radars, and, if MaRVs are deployed, the maneuverability of Soviet interceptors. Our estimates of the capabilities of the upgraded ABM defenses the Soviets are deploying at Moscow and rapidly deployable systems available to the Soviets are shown in table I. Intelligence Community agencies' differing judgments, shown in the table, about the potential capabilities of the rapidly deployable ABM system are based primarily on their assessments of the performance of its target-tracking engagement radar—designated the Flat Twin. The table shows ABM system capabilities for one-on-one intercepts of current types of US ICBM and submarine-launched ballistic missile (SLBM) RVs not accompanied by penetration aids. (One-on-one intercept capabilities do not account for the effects of multiple interceptors being used against multiple RVs.)

20. Agency estimates in the table show that, with handover data, these ABM systems could intercept all currently deployed types of US ICBM and SLBM RVs not accompanied by penetration aids, with the exception, according to one view,

21. Operating autonomously, without handover data, these systems according to one assessment would have virtually no practical capability to intercept ICBM and SLBM RVs with a single Flat Twin radar.

Therefore, for autonomous intercepts, many Flat Twin engagement radars would be needed at each defense site or in a defended region for defense against multiple RVs arriving simultaneously from different directions and for defense against MaRVs.<sup>9</sup> According to another assessment, a single Flat Twin radar would have the capability for autonomous operation over a useful threat sector. All-azimuth coverage is not required at all defended regions under a number of operational conditions. Where extended-azimuth coverage is desired, multiple radars could be assigned adjoining angular sectors. This view judges that one

<sup>9</sup> The holder of this view is the Deputy Director for Intelligence, Central Intelligence Agency.

<sup>10</sup> The holder of this view is the Deputy Director for Intelligence, Central Intelligence Agency.

radar could handle more than the ICBM corridor for a defended region and that several radars could cover the entire potential strategic ballistic missile threat region.<sup>9</sup>

22. For defense against reentry vehicles accompanied by penetration aids, chaff, and decoys one assessment is that the estimated limitations in the performance of Soviet ABM systems make it highly unlikely that current systems deployed or under development would be able to discriminate RVs

<sup>10</sup> Another assessment is that available Soviet discrimination techniques

make it possible that current Soviet ABM systems deployed or under development could defeat those penetration aids.<sup>11</sup> An additional view notes that, while such discrimination techniques may be available, it is not clear the Soviets are using them. In any event, they would be useful only against

<sup>12</sup> All agencies agree that the capabilities demonstrated by a new large Soviet radar under development, if incorporated into operational systems, would enhance discrimination performance.

23. The capabilities of Soviet ABM systems against evader-type maneuvering reentry vehicles

would depend on the specific characteristics of the reentry vehicles and accompanying penetration aids. Achievement of a good-quality defense would require multiple interceptors for each MaRV. In addition, even with handover data, multiple Flat Twin radars would be required at a site to be able to defend against two or more MaRVs arriving simultaneously, since their trajectories could prevent a single Flat Twin from tracking more than one of them.

<sup>9</sup> The holders of this view are the Director, Defense Intelligence Agency, and the Assistant Chief of Staff for Intelligence, Department of the Army.

<sup>10</sup> The holder of this view is the Deputy Director for Intelligence, Central Intelligence Agency.

<sup>11</sup> The holders of this view are the Director, Defense Intelligence Agency, and the Assistant Chief of Staff for Intelligence, Department of the Army.

<sup>12</sup> The holder of this view is the Assistant Chief of Staff, Intelligence, Department of the Air Force.

~~SECRET~~



13  
~~SECRET~~

24. Taking these differing estimates into account, we believe it is unlikely that the most critical performance parameters of Soviet ABM components will all be at the more threatening or less threatening end of the range of our present uncertainty about them. In any case, incremental improvements in the characteristics of Soviet ABM components under development, as well as new and follow-on components, are expected to make Soviet ABM systems more capable in the late 1980s and beyond. Thus, the likely technical capabilities of Soviet ABM systems which could be deployed appear to be sufficient to inject significant uncertainty into any US calculations of the effects of any planned ballistic missile attack.

#### Surface-to-Air Missile Systems

25. Our assessments of the capabilities of Soviet surface-to-air missiles to intercept strategic ballistic missile RVs are summarized in table 1. The only Soviet SAMs that any agency believes could potentially be used in this role are: the SA-5, a widely deployed SAM first introduced in the mid-1960s; the SA-10, which first became operational in 1980; and the SA-X-12, an advanced tactical SAM still under development.

26. SA-5 and SA-10. We do not believe the currently deployed SA-5 and SA-10 systems are suitable for use in ballistic missile defense. The Soviets are not likely to have developed these SAM systems with an ABM mission in mind, nor have they overtly conducted the upgrade program required to give these SAMs a significant ABM capability. We do not believe that the Soviets could covertly upgrade the SA-5 or SA-10 systems to achieve more than marginal capabilities to intercept strategic ballistic missile reentry vehicles.

27. An alternative analysis concludes that the SA-5 and the SA-10 may have a limited ABM role. According to this view, the SA-5 was intended as a dual system

With handover data the SA-5 system should be capable of providing a limited regional defense against RVs not accompanied by

penetration aids. According to this view, the SA-5, used in conjunction with a dedicated ABM system, could handle some RVs, thereby releasing the dedicated ABM system to defend against more difficult targets. This view also stresses the significant similarities between the SA-10 and the SA-X-12, a system with demonstrated antitactical ballistic missile (ATBM) capabilities, and believed to have the potential to intercept some ICBM and SLBM RVs as well. Because of these similarities, it is possible that the SA-10 also has antiballistic missile design features. The potential capabilities of the SA-10 are sufficient for it to be used in a preferential defense of small target areas. In addition, upgrade to improve potential ABM capabilities could be performed

28. We believe that in the absence of the ABM Treaty restrictions, and with an unrestricted modification and testing program, the Soviets could upgrade the capabilities of these systems to intercept certain strategic ballistic missile RVs. Such an upgrade, even if it provided much less capability than a dedicated ABM system, could be an important supplement to a ballistic missile defense—for example, a self-defense capability, a point defense against ballistic missiles launched from China or Europe, or possibly against SLBM RVs.

29. SA-X-12. We believe the SA-X-12, an advanced tactical surface-to-air missile system, will have both antiaircraft and antitactical ballistic missile capabilities. (See figure 2.) The system has two interceptors, one of which has higher acceleration, speed, and range than the other.

The SA-X-12 system could be ready for deployment in the next year or so with the lower performance interceptor and somewhat later using the higher performance interceptor.

30. Available evidence suggests that the SA-X-12 is intended for use by Soviet ground forces. However, a system with antitactical ballistic missile defense capabilities could have many of the features one would expect to see designed into an ABM system. Making a

"The holder of this view is the Director, Defense Intelligence Agency.

Figure 2  
SA-X-12 System Components

Engagement radar

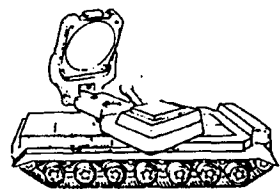

Command and control vehicle

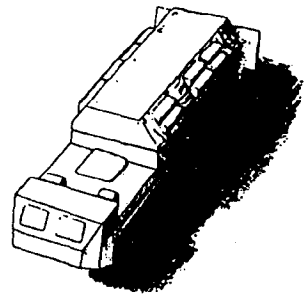

Acquisition radar

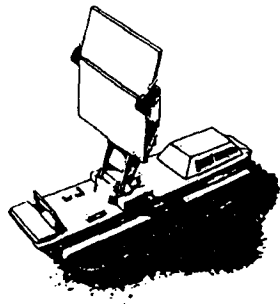

Transloader

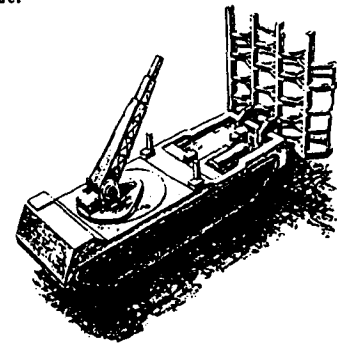

TELAR for lower acceleration interceptor\*

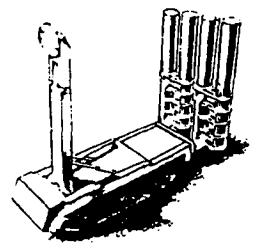

TELAR for high-acceleration interceptor\*

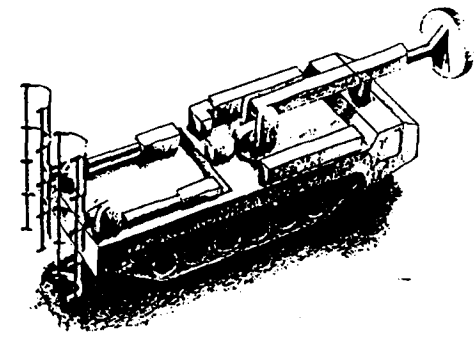

\* TELAR - transporter, erector, launcher, and radar.

number of assumptions about design features the system could have. [ ] we conclude that the SA-X-12 with the higher acceleration interceptor could have the capability to intercept all current types of US ICBM and SLBM RVs except [ ] As shown in table 1, the SA-X-12 could have a significant autonomous capability to defend a small area against US ICBM and SLBM RVs. There is an alternative view that there are insufficient data to characterize the capabilities of the SA-X-12 against strategic ballistic missiles as "significant." On the basis of less generous assumptions about the system's design features, its capability would be marginal.<sup>15</sup>

### Capabilities for ABM Deployments

#### Upgraded ABM Defenses at Moscow

31. The Soviets are in the process of upgrading and expanding the ballistic missile defenses at Moscow, thus far within the limits of the ABM Treaty (see figures 3 and 4):

- The upgraded defenses at Moscow include silo launchers for a high-acceleration missile to conduct intercepts within the atmosphere and for a long-range missile to conduct intercepts outside the atmosphere. As long as the ABM Treaty remains in effect the Soviets will deploy the maximum number—100 launchers—at Moscow.
- While we are not certain of all the components that will make up the upgraded defenses, the two large radars providing battle management support (Dog House and Cat House) will probably remain part of the Moscow defenses.
- A new large phased-array radar is under construction near Pushkino north of Moscow, which will provide 360-degree coverage and is probably intended to control ABM engagements. We are unable to judge whether the Pushkino radar will have the capability for search and target acquisition. If it does, we believe it would be more likely to have short-range rather than long-range search and target acquisition capabilities. If it were to have long-range search and target acquisition capabilities, the Pushkino radar would

<sup>15</sup> The holders of this view are the Assistant Chief of Staff, Intelligence, Department of the Air Force, and the Director of Naval Intelligence, Department of the Navy.

close existing gaps in radar coverage by the Dog House and Cat House and could provide target acquisition and tracking data for expanded ABM deployment in the western USSR. If it were to have short-range search and target acquisition capabilities, it would be able to provide battle management support for defenses at Moscow, reducing the need for the Cat House and Dog House radars.

#### Options for Deployments Beyond Treaty Limits

32. We have postulated four options for Soviet ABM deployments which represent an expansion beyond ABM Treaty limits of the upgraded defenses now being deployed at Moscow, with increasing numbers of ABM launchers for defense of areas beyond Moscow. For the three options that postulate a widespread defense, we have assumed a rapidly deployable system using components the Soviets are developing, consisting of radars for target tracking and missile guidance, aboveground launchers, a long-range interceptor, and a high-acceleration interceptor like the US Sprint. (See figure 5.) These components would provide the Soviets a two-layer defense—that is, a defense permitting intercepts outside and inside the atmosphere. The deployment options we have postulated are:

- Option 1: A 500-launcher defense at Moscow.
- Option 1A: A 500-launcher defense at Moscow and 900 aboveground launchers in the western USSR.
- Option 2: A 500-launcher defense at Moscow and 1,500 aboveground launchers throughout the USSR.
- Option 3: A 500-launcher defense at Moscow and 3,000 aboveground launchers throughout the USSR.<sup>16</sup>

<sup>16</sup> We emphasize that our four options were created for illustrative purposes only; in any actual deployment the size, target coverage, and mix of interceptors and supporting radars could be different from those we have assumed. Thus, variations in these factors can be made for use in US defense analyses. The numbers of launchers in each option represent different levels of effort, and are not based upon assumed Soviet requirements to defend against a particular US attack or to provide a given level of defense of key targets at Moscow or beyond. In our options we have assumed ABMs would be deployed to achieve coverage of military and nonmilitary targets of high value to the Soviets. The Soviets might choose a deployment pattern that would maximize the defense of specific types of targets—for example, heavy ICBM silos.

Figure 3  
Present Status of Upgraded Ballistic Missile Defenses at Moscow

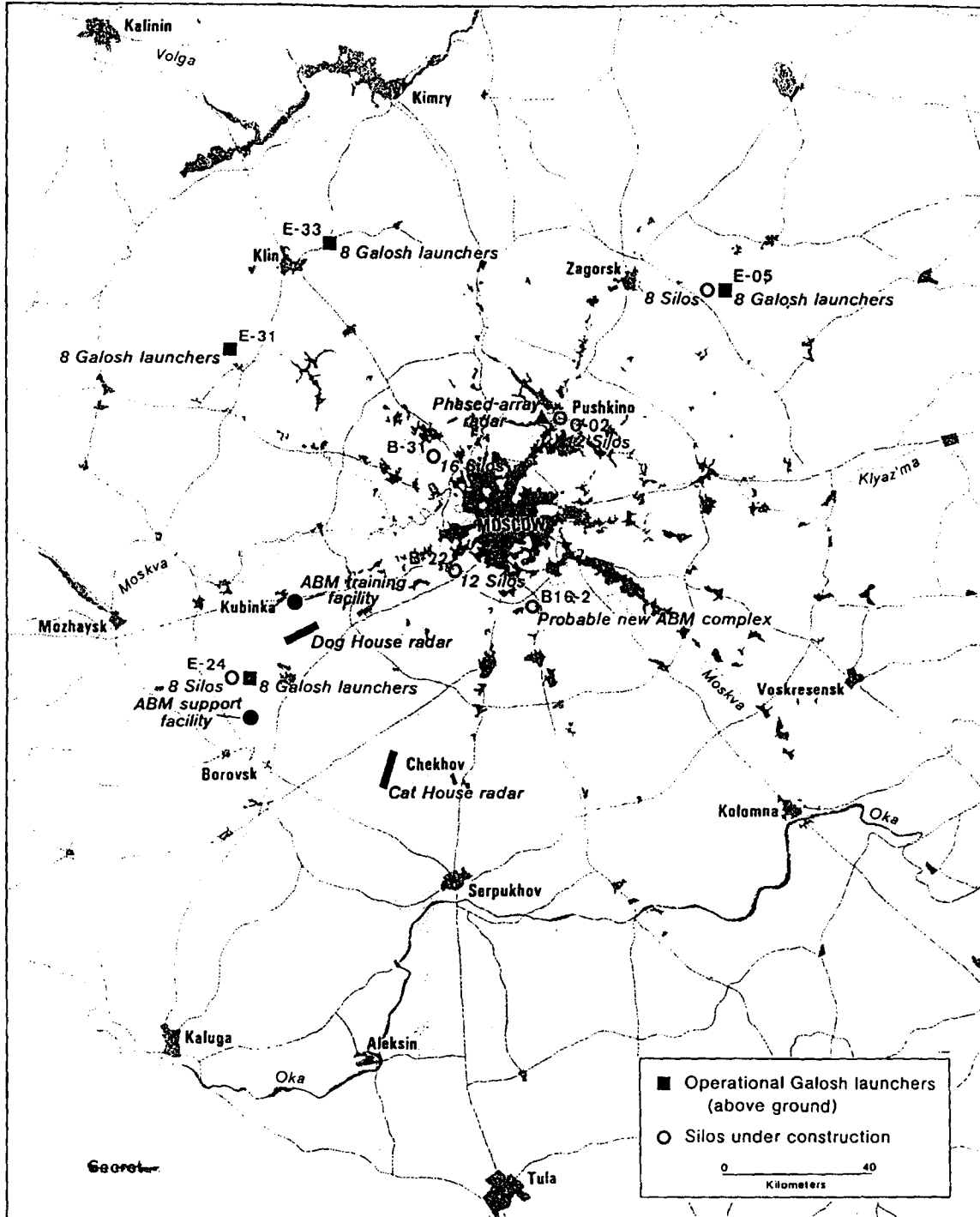

63786A 10-82

~~SECRET~~

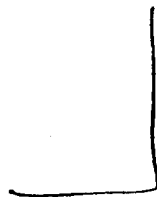
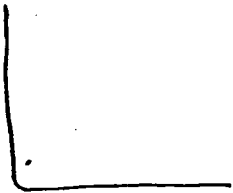
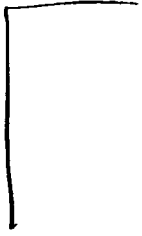

~~SECRET~~

**Figure 5**  
**Potential Elements of a Rapidly Deployable ABM System**

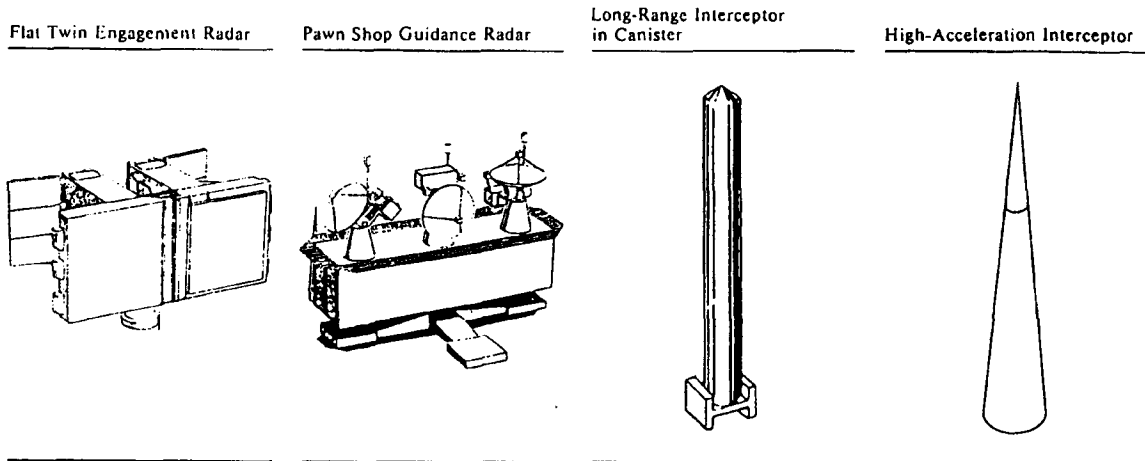

Note: Drawings not to scale.

~~SECRET~~

587835 10-82

#### Radars for Battle Management Support

33. Among the factors affecting the pace of Soviet deployments are the requirements for radars providing battle management support, about which there are uncertainties and differences of view. While agencies disagree about the autonomous capabilities of the rapidly deployable ABM system we have assumed, there is agreement that the ABM systems associated with the four deployment options would operate most effectively using handover data from large long-range search and target acquisition radars. The Soviets have a number of large phased-array radars that, to varying degrees, could provide ballistic missile early warning, attack assessment, and battle management support data. These radars include the two radars at Moscow—Dog House and Cat House—and radars on the periphery of the Soviet Union—15 older Hen House radars and five new radars operational or under construction. These five new radars will have better capabilities

than the Hen House. The estimated azimuthal coverage of these large radars, as well as the Pushkino radar, is shown in figure 6.

34. All agencies agree that the large phased-array radars on the periphery of the USSR have the technical potential to provide target-tracking data for support of a widespread ABM system, but agencies disagree about their suitability—their location and vulnerability—for a battle management support role. Agencies differ about whether the Soviets would deploy a widespread ABM system that relied on these radars for battle management support, or instead would require, to assure the system's effectiveness, a network of other radars in the interior of the USSR—prohibited by the ABM Treaty—that have not yet been observed to be under construction.

35. One view holds that the ABM defenses that the Soviets could deploy which relied on the peripheral



**Figure 6**  
**Estimated Azimuthal Coverage of Ballistic Missile Detection and Tracking Radars**

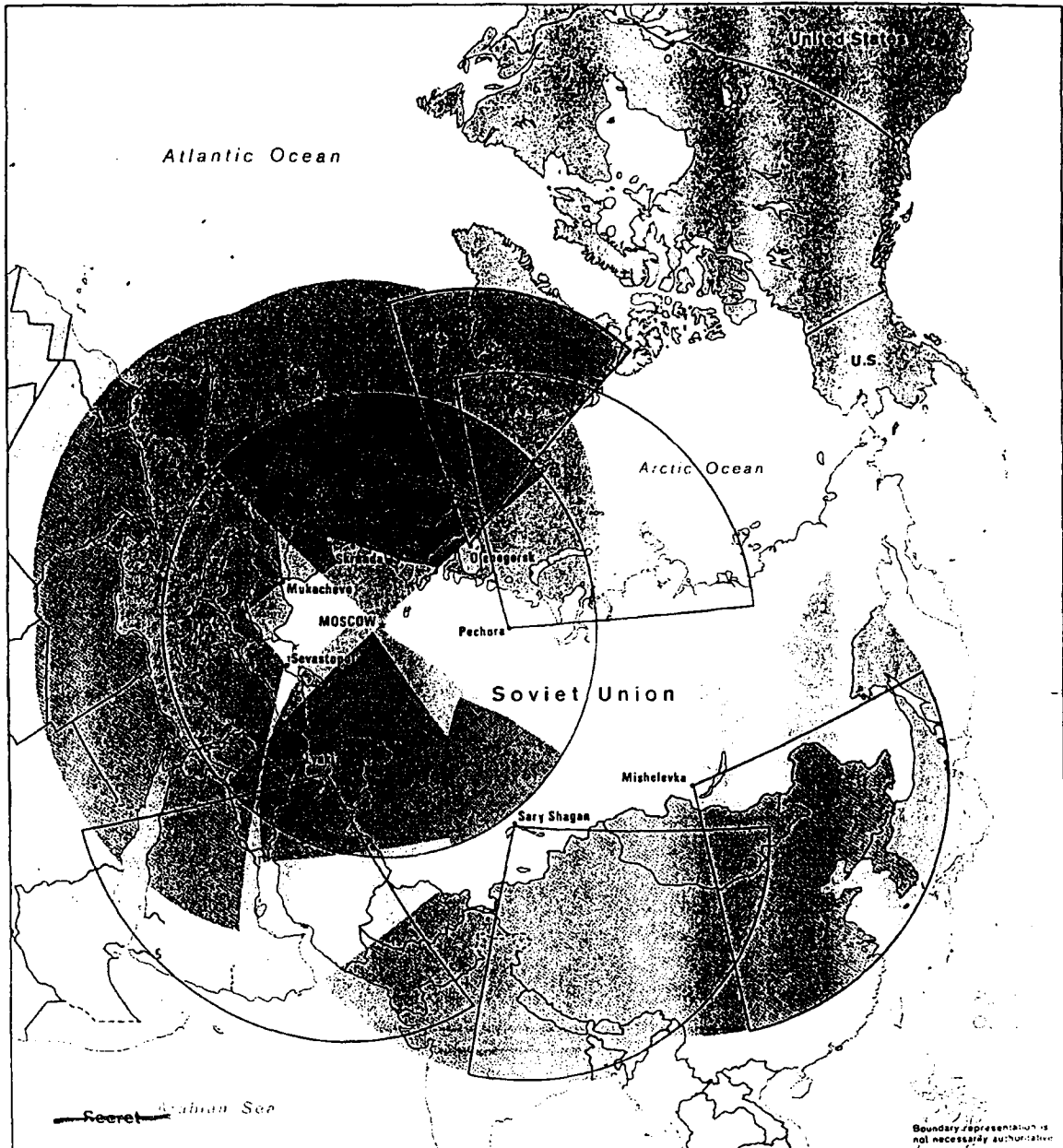

~~Secret~~

Boundary representation is not necessarily authoritative

6325 19 9 80

- ▷ New phased-array radars under construction
- ▨ Hen House radars
- ▩ Dog House and Cat House radars
- Pushkino radar

radars for battle management support could be quickly and easily overcome by the United States because of the vulnerability of the radars to attack. Therefore, the large radars are unlikely candidates for the key elements upon which a widespread ABM defense would depend:

- The forward locations of the peripheral radars and their present limited defenses make them more vulnerable to destruction by ballistic missiles as well as aircraft and cruise missiles. Radars in the interior would not be vulnerable to the same degree. The peripheral radars do not fill the existing gaps in battle management coverage and only look outward, making them vulnerable to blind-side attacks by ballistic missiles, regardless of the number of ABMs deployed to defend them.
- Because of their low operating frequencies they are extremely susceptible to electromagnetic effects (such as blackout) of nuclear bursts. [

] warheads detonated beyond the range of defenses could render such a radar useless for [ minutes to hours. [

- In order to be potentially effective against current US ballistic missiles, a widespread ABM deployment beyond the western USSR would require a network of four or five new radars. We assume the new radars would provide 360-degree coverage, and would be located in the interior where they would be less vulnerable to attack. Finally, we assume the new radars would operate at a higher frequency which would make them less susceptible to nuclear weapons effects.<sup>17</sup>

36. Another view holds that the large peripheral radars, including the older, less capable Hen House radars, are suitable for providing battle management support to a widespread ABM deployment:

- Given the most likely scenarios, it is unlikely that cruise missiles or aircraft would suppress these radars in time to prevent precision tracking of attacking strategic missiles. In addition, radars

<sup>17</sup> The holders of this view are the Deputy Director for Intelligence, Central Intelligence Agency, and the Director, Bureau of Intelligence and Research, Department of State.

located on the periphery would be no more vulnerable than those in the interior to suppression attacks using ballistic missiles. Likely increases in the ballistic missile defense of the peripheral radars in the course of a widespread ABM deployment would improve their protection from blind-side attacks.

- All radars are susceptible to electromagnetic effects of nuclear bursts, but rendering these radars ineffective by such means would be a significant operational undertaking. [

- Moreover, radars on the periphery would be unaffected by nuclear bursts in the interior. Similarly, nuclear bursts associated with defense of the peripheral radars would not blind ABM engagement radars in the interior.<sup>18</sup>

37. If, for whatever reasons, the Soviets decided to deploy ABM defenses in excess of Treaty limits, we believe the circumstances surrounding such a decision would call for deployments to be in place as rapidly as possible. To this end, we believe the Soviets would make use of the large radars operational or under construction, including those on the periphery of the USSR, for battle management support. We believe the Soviets would provide some active defenses for the peripheral radars and would make evolutionary improvements in these radars. In addition, they would probably construct new radars in the interior to improve battle management support. The large Dog House and Cat House radars near Moscow could provide battle management support for ABM deployments throughout much of the western USSR, as in Option 1A. Such a system, in order to be viable, would probably require additional battle management support—from the Pushkino radar (provided it had long-range search and target acquisition capabilities), from a new search radar (possibly at Moscow), and from the large peripheral radars. There is an alternative view that—while not precluding Soviet deployment of additional acquisition radars for redundancy, possibly even

<sup>18</sup> The holders of this view are the Director, Defense Intelligence Agency, and the Assistant Chief of Staff for Intelligence, Department of the Army.

large numbers with less sophistication than the peripheral radars—holds that at present there is no basis in evidence for such an eventuality.<sup>19</sup>

Potential ABM Deployment Rates

38. In assessing Soviet capabilities for ABM deployments we have also considered requirements for supporting command, control, and communications networks, for production of nuclear materials and warheads, and for manpower and troop training. We believe that these would not be pacing factors in the rate of deployment. Launch site construction and ABM component production, however, probably would be. There are uncertainties and differences of view, as explained in volume II, about the effect of these factors on the rate at which the Soviets could deploy silo and aboveground ABM launch sites. As a result of these differences, as well as differences about the requirements for battle management support radars, we have postulated three forces with differing deployment rates for each of the deployment options described in paragraph 32. In all three forces, deployment of the expanded defenses at Moscow is paced by the rate of silo construction. A 500-launcher defense at Moscow could be completed several years sooner if aboveground launchers were used instead of silos. All three force postulations assume, for the purposes of the Estimate, a high-priority program in which the Soviets would implement the necessary production and deployment initiatives during 1982 (or, in this supposition, already have taken such initiatives) and that the deployments in excess of ABM Treaty limits, under this assumption, would begin about 1985.<sup>20</sup> (The likelihood of such deployments is addressed later.) The three force postulations are:

- Force A, which is paced by the construction schedule for engagement radar production, launch site deployment, and, for widespread deployments beyond the western USSR, deployment of a network of large new radars.
- Force B, which is paced by the rate of engagement radar production and launch site deployment

<sup>19</sup> The holders of this view are the Director, Defense Intelligence Agency, and the Assistant Chief of Staff for Intelligence, Department of the Army.

<sup>20</sup> For purposes of this Estimate, we have arbitrarily chosen 1982 as the date for implementing the necessary production and deployment initiatives. If the Soviets have already made a deployment decision, the sustained peak ABM deployment rates we have projected could be achieved a year or two earlier.

ments and for which we assume that the radars operational or under construction will provide the requisite battle management support.

- Force C, which is based on the same assumptions as Force B, except that it is paced by the rate of launch site construction and not by the rate of engagement radar production. It also assumes a mix of silo and aboveground launchers at Moscow.

39. These three forces for each of the deployment options are shown in figure 7. As a result of our assumptions more significance should be attached to the pace of deployments we have postulated rather than to their ultimate size and composition. Under the various force postulations, significant Soviet ABM deployments could be operational by the late 1980s or early 1990s, as shown in table 2, assuming that the Soviets made the decision to initiate them this year. However, because of differing assumptions about pacing factors, the dates of completion of the deployments could vary.

Indications of Postulated ABM Deployments

40. [ ]

41. [ ]

[ ]

**Figure 7**  
**Potential Soviet Deployments Beyond ABM Treaty Limits\***

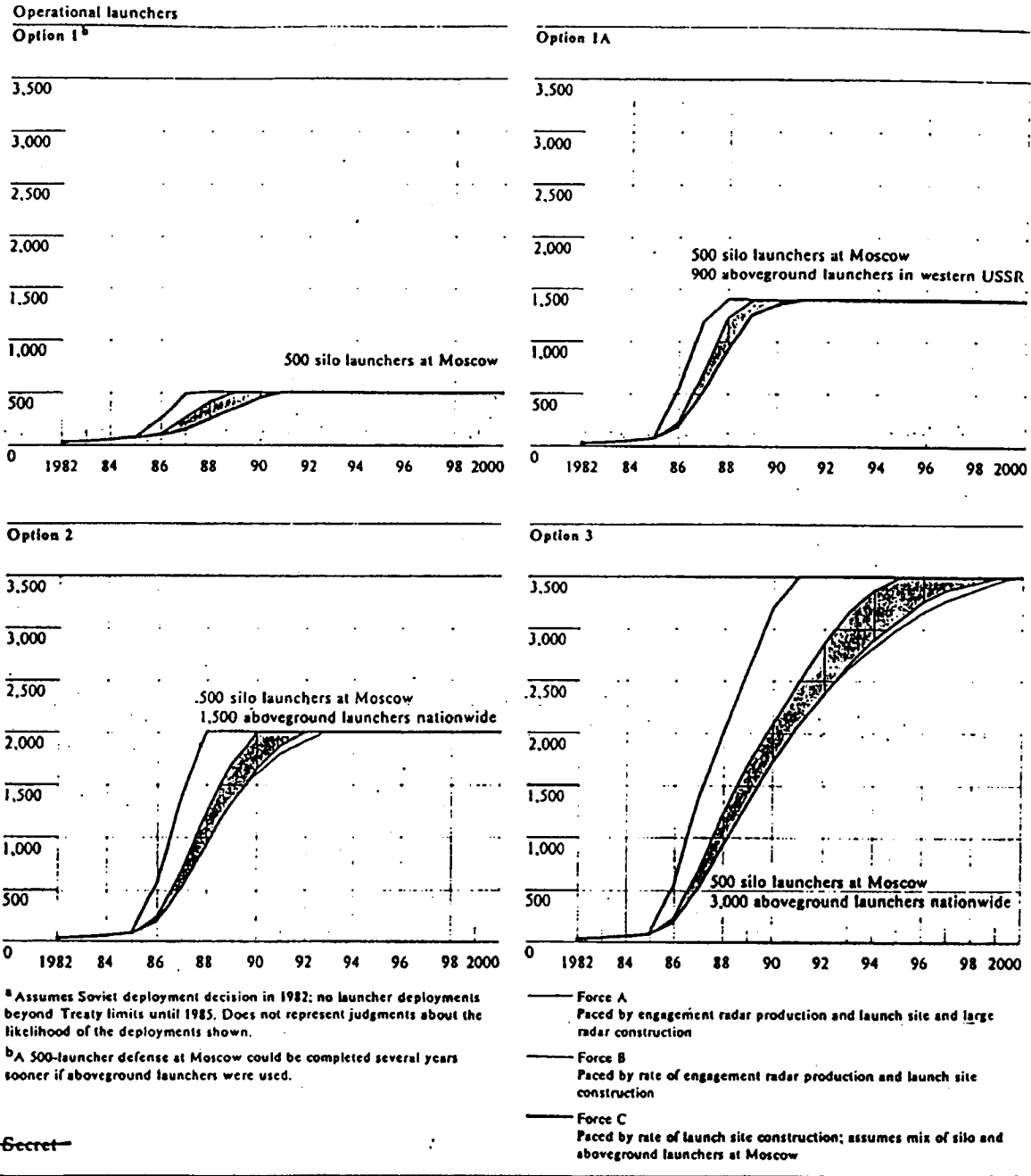

\* Assumes Soviet deployment decision in 1982; no launcher deployments beyond Treaty limits until 1985. Does not represent judgments about the likelihood of the deployments shown.

<sup>b</sup>A 500-launcher defense at Moscow could be completed several years sooner if aboveground launchers were used.

Table 2

Dates of Completion for Postulated Soviet ABM Deployments

	Force A	Force B	Force C*
500-launcher defense at Moscow (Option 1) <sup>b</sup>	1991	1989-91	1988
1,400-launcher defense for key targets in western USSR (Option 1A)	1991	1989-91	1988
2,000-launcher defense for key targets nationwide (Option 2)	1993	1990-92	1988
3,500-launcher defense for key targets nationwide (Option 3)	2000	1995-99	1991

\* There is an alternative view that Force C would be implausible because the postulated deployment rates would seriously compete with the Soviets' ability to carry out other military programs. The holder of this view is the Assistant Chief of Staff, Intelligence, Department of the Air Force.

<sup>b</sup> A 500-launcher defense at Moscow could be completed several years sooner if aboveground launchers were used instead of silos.

~~Secret~~

[

]

42. [

]

### Economic Factors

43. The estimated 10-year procurement and operating costs of a widespread, 2,000-launcher ABM defense (Option 2) could amount to some 25 percent of strategic defense expenditures and about 13 percent of spending on all Soviet strategic forces. During 1983-92, the estimated costs of a 100-launcher defense under Treaty limits would amount to about 5 percent of strategic defense costs and a little over 2 percent of the spending on all strategic forces, similar to the proportion of spending for ABMs in the 1970s.<sup>11</sup>

<sup>11</sup> There are considerable uncertainties in the cost-estimating methodology applied to Soviet military programs.

44. While there are differing views about the economic implications of a widespread Soviet ABM deployment on other military programs and on the Soviet economy, we believe that, if Soviet leaders concluded that such a program was necessary, economic considerations would not deter them from pursuing it. It should be noted, however, that the circumstances under which the Soviets would embark on such a deployment would probably involve increased efforts in a number of other military programs by the USSR (and the United States). These programs and the cost of the widespread ABM deployment would further strain an already strained Soviet economy.

### II. PROSPECTS FOR DIRECTED-ENERGY WEAPONS

45. The Soviets' assessment of their prospects for developing operationally practical directed-energy weapons for ballistic missile defense could affect their decision about ABM deployments in excess of Treaty limits. The USSR has been working on military applications of directed-energy technology as long as and more extensively than the United States. The Soviets have the expertise, manpower, and resources to develop those directed-energy weapon and military support systems that prove to be feasible. Directed-energy systems for ballistic missile defense, if they prove to be feasible and practical, would most likely be used in conjunction with conventional ABM systems and supporting radars, at least initially.

~~SECRET~~

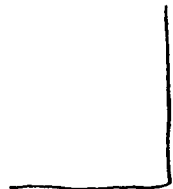
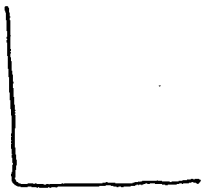
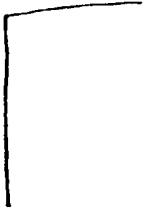

25  
~~SECRET~~

46. Of the types of directed-energy technology with potential application to ballistic missile defense, evidence is strongest that the Soviets are pursuing development of high-energy laser ABM weapons. We believe that the Soviets have a program to develop laser weapons for ballistic missile defense, although its full scope, concept of weapon operation, and status are not clear. There are limited indications that the Soviets have performed research to investigate the feasibility of particle beam weapons (PBW).

### Laser Systems

#### Ground-Based

47. There are many unknowns concerning the feasibility and practicality of ground-based laser weapons for ballistic missile defense. We do not know, for example, how the Soviets would handle the problem of heavy cloud cover prevalent in many areas of the USSR containing facilities the Soviets would want to protect. Nevertheless, we are concerned about the magnitude of the Soviet effort. It would be consistent with Soviet philosophy and practices to deploy a weapon system even if its capability were limited under some conditions. There are large uncertainties in any estimate of when a Soviet laser weapon could be available. We expect that the high-energy laser facility at the test range will be used during the 1980s for testing the feasibility of ballistic missile defense applications. If feasibility is demonstrated, our judgment is that a prototype ground-based laser weapon for ballistic missile defense would then have to be built and would not begin testing until the early 1990s. An initial operational capability (IOC) probably would not occur until after the year 2000. An alternative view holds that, if tests from this facility prove successful in engaging ballistic missile RVs, the Soviets would not have to construct a new prototype weapon, and therefore a deployed ground-based laser weapon system for ballistic missile defense could reach IOC by the early-to-middle 1990s.<sup>44</sup>

#### Space-Based

48. While space-based weapons for ballistic missile defense are probably feasible from a technical standpoint, such weapons require significant technological

<sup>44</sup> The holder of this view is the Director, Defense Intelligence Agency.

advances in large-aperture mirrors and in pointing and tracking accuracies. They would also require very large space boosters having perhaps 10 times the capacity of those now in use. We expect the Soviets to have such boosters in the late 1980s. In view of the technological requirements, we do not expect them to have a prototype space-based laser weapon system until after 1990 or an operational system until after the year 2000.

### Particle Beam Weapons

#### Ground-Based

49. Soviet particle beam weapon (PBW) technology and related efforts have reached a level suitable for conducting experimental research on the feasibility of several applications, including ground-based ballistic missile defense. We doubt that the Soviets are yet capable of building PBWs, or that they are close to solutions for the technical problems involved. We believe Soviet development of any prototype ground-based PBW, if feasible, would be at least 10 to 15 years in the future.

#### Space-Based

50. Space-based PBWs would not be encumbered by the atmospheric propagation effects of ground-based PBWs and therefore appear more feasible; the issue is one of developing an operationally practical system. The Soviets have a research program on at least some of the aspects of space-based PBWs. These weapons would be quite different from the ground-based PBWs; the particle energy and current requirements would be much lower and the systems requirements would be far less stressing. Nevertheless, the technical requirements for such a system, such as extremely precise pointing and tracking, are severe, and it is unlikely that the Soviets could develop a prototype space-based particle beam weapon to destroy hard targets like missile RVs before the end of the century. According to one view, systems intended to disrupt the electronics of ballistic missiles, requiring significantly less power, could probably be developed and deployed in the 1990s.<sup>45</sup>

<sup>45</sup> The holders of this view are the Director, Defense Intelligence Agency, and the Assistant Chief of Staff for Intelligence, Department of the Army.

### III. CAPABILITIES OF SOVIET BALLISTIC MISSILE DEFENSES

#### Upgraded Moscow Defenses Within Treaty Limits

51. The projected upgrade of the defenses at Moscow with 100 ABM launchers—the Treaty limit—will provide the Soviets with a much more reliable, two-layer capability to defend critical targets at Moscow against an attack by some tens of current types of US RVs and against increasingly sophisticated third-country missiles. Like the present system, the long-range, exoatmospheric interceptors in the upgraded defenses could intercept RVs targeted against areas well beyond Moscow.<sup>44</sup> In a large-scale attack, the projected 100 interceptors would quickly be exhausted, but they might be effective in preferentially defending selected targets in the Moscow area, such as national command and control facilities. The Soviets may close existing gaps in coverage of radars providing battle management support of the Moscow system, either by constructing a new radar or radars if the Pushkino radar does not have a long-range search and target acquisition capability—or, according to one assessment, possibly by relying on the large peripheral radars to provide battle management support.<sup>45</sup>

#### Expanded Defenses at Moscow

52. The upgrade to the defenses at Moscow is expected to provide the Soviets with a foundation for expanding their defenses. With a firepower level of about 500 interceptors (Option 1), the Soviets could make hardened targets around Moscow, especially command bunkers, less vulnerable to a substantial US force of attacking RVs. The leakage likely to result from such an attack would cause severe damage to most of the aboveground, unhardened facilities and to some of the hardened target facilities as well. Against a smaller scale attack, a defense like Option 1 would

<sup>44</sup> We believe the upgraded defenses at Moscow are intended to protect targets in the Moscow area. Similarly, the expanded 500-launcher defense at Moscow included in the four deployment options which we postulated was envisioned for defense of targets in the area of Moscow. However, exoatmospheric interceptors launched from sites at Moscow could intercept US ICBM and SLBM RVs targeted against areas a few hundred kilometers distant. The degree of defense afforded targets beyond Moscow would, of course, depend on the number of interceptors available and whether penetration aids were used by the attacking force.

<sup>45</sup> The holder of this view is the Director, Defense Intelligence Agency.

allow the Soviets to spread their interceptor coverage to a larger number of targets over a larger area. The effectiveness of such a defense against attack by third countries, such as China, would be considerable.

#### Widespread ABM Defense

53. If the Soviets were to deploy an ABM defense involving as many as 1,400 to 3,500 launchers, as in Options 1A, 2, and 3, assuming the deployed systems were reasonably effective, the potential effect on the US strategic missile force would be substantial. A US first strike in the face of such a heavy defense would be degraded, perhaps to a significant degree. A US second strike would be degraded even more, because the lower number and rate of RV arrivals in most areas would result in lower leakage rates for the defense.

54. The actual effectiveness of such a defense would depend, not only on the performance of the deployed ABM systems, but also on the vulnerabilities of key elements of the network and the potential of an attacking force to exploit them. We have not analyzed these problems in detail. For example, in addition to protecting the key targets, considerable numbers of interceptors would have to be allocated for protection of the radars providing battle management support. Hundreds of RVs might be required for a direct attack on all these radars for the attacker to have high confidence of their destruction. An attack to open selected corridors would require considerably fewer RVs to give the attacker high confidence in neutralizing the targeted radars.

Given the uncertainties involved, the prospect of an attack with only a few RVs per radar would diminish a Soviet planner's confidence in the performance and survivability of the radars. Planning and execution of an attack to destroy or neutralize these radars would be more difficult under conditions in which the United States rode out an initial Soviet strike, because of the reduced number of surviving US weapons and the potentially degraded US capability to execute a coordinated attack.

55. We have not quantitatively assessed, and are uncertain about, the potential ability of a widespread



ABM system to reduce overall damage and to protect key military functions. It would probably be more effective against SLBMs than against ICBMs, if adequate coverage of SLBM approaches were provided by battle management support radars. US countermeasures such as decoys, chaff, and maneuvering RVs could reduce its effectiveness. [

the defenses at Moscow is currently consistent with the limits of the ABM Treaty, holds that the evidence is insufficient to judge whether or not the Soviets have near-term objectives to deploy beyond the Treaty limits. [

[ In any case, widespread Soviet deployment of an ABM system, even if US evaluations indicated it could be overcome by an attacking force, would complicate US attack planning and create major uncertainties for US planners about the potential effectiveness of a US strike. Additionally, according to one view, any evaluation of the effects of a widespread ABM defense to reduce damage should consider the potential ABM capabilities of the SA-5 and SA-10 systems, which could further complicate US attack planning."<sup>4</sup>

56. If the capabilities of the SA-X-12 noted in table 1 are realized, its potential contribution to ballistic missile defenses would be of growing concern as it becomes widely deployed in the USSR and Eastern Europe in the mid-to-late 1980s.

#### IV. FUTURE SOVIET ABM DEPLOYMENTS

57. There are a number of situations involving ABM Treaty revisions, abrogation, or withdrawal initiated by the United States or the USSR which could result in Soviet deployment of ABMs beyond current Treaty limits. At present, the Soviets apparently value the ABM Treaty for both political and military reasons; they are probably concerned about a major US commitment to ballistic missile defense. We do not foresee a Soviet initiative to revise, abrogate, or withdraw from the ABM Treaty within the next several years. The Soviets do not need to revise the ABM Treaty limits to support what we believe to be their near-term objectives—the currently observed modernization of the Moscow ballistic missile defenses. There are considerable uncertainties about what situation will prevail beyond about the mid-1980s. There is an alternative view that, while noting that the upgrade to

<sup>4</sup> The holder of this view is the Director, Defense Intelligence Agency.

#### Revisions to the ABM Treaty

58. The United States is considering ICBM basing options which include ABM defenses that could require revision of the ABM Treaty. Any US defense of MX which the Soviets view as viable would cause a basic reevaluation of their offensive and defensive strategies. The Soviets' response would depend on a number of factors, including the size of the additional defenses contemplated by the United States. They would be resistant to a US initiative to defend MX; should the United States insist on Treaty modifications, the Soviets might flatly refuse, thus forcing the United States to withdraw from the Treaty to defend MX. Nevertheless, should the Soviets agree to such a US-proposed modification, it is unclear to us what concessions they would try to extract in a revised Treaty—whether their ABM program objectives would be to increase deployments at Moscow, along the lines of Option 1, to defend ICBMs, or to establish ABM deployment areas elsewhere in the Soviet Union. At a minimum the Soviets probably would make other adjustments in their strategic forces, such as increasing their offensive system deployments and giving them better capabilities to penetrate US ABM defenses:

- We have not specifically examined a deployment option for ICBM defense alone, but the systems the Soviets could deploy in the mid-to-late 1980s could be used to provide a degree of ICBM defense, such as a defense of their heavy ICBMs.
- The advantage of providing a better defense for important targets in the Moscow area—intended, for example, to defend against Chinese attacks—could be offset by the disadvantage of allowing the United States comparable numbers of ABMs for defense of ICBMs. We would be concerned, however, that the expanded ABM production and deployments that such expansion would require, probably including radars at Moscow to

<sup>4</sup> The holder of this view is the Director, Defense Intelligence Agency.

close gaps in battle management coverage, would put the Soviets in an improved position to extend their defenses beyond Moscow.

We doubt that the Soviets themselves would initiate revision of the Treaty in order to deploy ABM defenses as noted above.

#### US Withdrawal From the Treaty

59. If the United States were to withdraw from the ABM Treaty, we believe that the Soviets would increase their ballistic missile deployments and improve their capabilities to penetrate a US defense. While various factors might potentially constrain Soviet ABM deployments, we believe that, under the conditions that would be likely to attend US withdrawal, the Soviets' damage-limiting objectives would almost certainly lead them to rapidly deploy a widespread ABM system on the scale of Option 2, for completion in the early 1990s, as noted below. They might not immediately begin such a widespread deployment after the US withdrawal, but rather would expand the Moscow defenses while assessing US intentions and their own options.

#### Soviet Abrogation of the Treaty

60. While all agencies agree that the Soviets are not likely to abrogate or withdraw from the ABM Treaty within the next two years or so, there are alternative views (see paragraphs 62 to 64) about the chances that they would do so after that time and about the large radars for battle management support. These alternative views are based in part on differing assessments of the potential effectiveness of the ABM defenses the Soviets could have by the late 1980s to early 1990s. All agencies agree, however, that, if the Soviets abrogated the ABM Treaty, they would deploy a widespread ABM defense in the western USSR, by the late 1980s to early 1990s, and most agencies agree the defenses would be extended east of the Urals. To explain their actions and minimize short-term political losses the Soviets would claim that the United States was about to abrogate or that, because of US offensive and defensive force actions, the USSR was forced to act.

61. We believe that if the Soviets decided to abrogate or to withdraw from the Treaty at any time during the next 10 years, their decision would be based

on the intention to initiate deployment of a widespread system, in both the western USSR and east of the Urals, on the scale of Option 2, for completion in the early 1990s:

- If either the USSR or the United States abrogated the ABM Treaty, we believe the Soviets would deploy a widespread ABM defense using the large radars now operational or under construction for battle management support, and would construct a network of new large radars in the interior of the USSR, less vulnerable than those on the periphery. They would move to enhance the Moscow ABM defenses—thereby protecting the highest concentration of national command, control, and communications, political, military, and military industrial targets in the Soviet Union—and would expand these defenses as quickly as possible to cover other critical targets in the western USSR, including many of their ICBM complexes. A widespread western USSR deployment could be completed by the late 1980s to early 1990s, if key decisions were made in 1982, as postulated in the several options.
- The Soviets would also deploy by the early 1990s ABMs to protect selected important targets east of the Urals, with battle management support provided by the large peripheral radars, and then by the new interior radars as they became operational. Some of these radars also would be built in the western USSR to improve the battle management support capabilities for ABM deployments there. The pace of construction of the large radars would depend substantially on the degree of urgency and the availability of necessary components; these radars probably could be completed by the early 1990s.
- The Soviets probably would not have high confidence in the capabilities of this widespread ABM defense against a large-scale undegraded US missile attack. On the other hand, the Soviets might believe that a well-coordinated initial strike on US military forces and supporting command, control, and communications facilities would result in a poorly coordinated, greatly reduced US retaliatory strike. The degree of protection they might achieve against this type of US attack by a combination of widespread ABM

defenses, improved air defenses, and passive defenses might weigh heavily in any Soviet assessment of the USSR's ability to satisfy military objectives. We cannot evaluate the extent to which this factor would influence the Soviets to abrogate the Treaty, but we believe it would be the key military factor if such a step were taken.

On balance, we believe there is a fairly low but nevertheless significant chance (about 10 to 30 percent) that the Soviets will abrogate the Treaty and deploy ABMs in excess of Treaty limits in the 1980s. We believe the Soviets would weigh the military advantages of such a deployment as being outweighed by the disadvantages, especially that of energizing the United States and perhaps its Allies into a rapid and sustained growth in overall military capabilities, both conventional and nuclear, that could lead to an erosion in the 1990s of Soviet gains achieved in the 1970s and 1980s.

62. An alternative view holds that it is unlikely (less than a 10-percent chance) that the Soviets would take the initiative to abrogate the ABM Treaty in the 1980s. Soviet benefits from the Treaty, under current and projected conditions, far outweigh the potential gains from abrogation. This view is based on the following:

- The ABM Treaty allowed the USSR to significantly close the gap in ABM research and development and to surpass the United States in rapid deployment capability. Furthermore, as noted in paragraph 13, the Treaty still places a drag on US research and development for ABM.
- The asymmetries in the value of a single ABM deployment greatly favor the USSR. The value of what lies within the Moscow ABM deployment area is very high, as noted in paragraph 61. No similar concentration exists in the United States. Therefore, the USSR's strong incentive to protect this asymmetry is another reason why Soviet leaders are unlikely to abrogate the Treaty.
- SALT limits give Soviet defense planners certainty about the inventory of US RVs. Thus, when the strategic defense of the USSR is planned, the Soviets know the size (outer limits) of attack to expect. This makes it possible to estimate the requirements for various levels and types of defense. Thus, there is a strong Soviet incentive to retain both the ABM Treaty and the RV limits under SALT.

— Significant technological breakthroughs by the Soviets that would drastically alter their ABM capability are unlikely in the 1980s. Even a breakthrough in principle would not be easy to apply in practice within the decade.

In sum, the Soviets have effectively combined force structure development with arms control in SALT I and II, as noted in paragraph 13. Thus the holder of this view believes there are virtually no objective reasons for the Soviets to abandon the treaties unless current conditions change substantially. This view emphasizes, however, that, while the probability of abrogation is very low in the 1980s, the Soviets have a motivation to deploy a widespread ABM system and there is a higher probability of deployment in the 1990s. To complete their strategic defenses, the massive and expensive air defense system (and the passive defenses) must be complemented by ABMs. Furthermore, their ABM program would permit widespread deployment in only a few years, a time during which, at least initially, the deployment could outpace potential US responses.<sup>22</sup>

63. Another alternative view holds that the Soviets are unlikely to abrogate the ABM Treaty during the 1980s, because the conditions that led to Soviet acceptance of the Treaty—including the perception of the potential for US technological and manufacturing capabilities to outstrip those of the USSR—still pertain; the political costs of abrogation, particularly in Western Europe, would be a further restraining factor; and, finally, the Soviets will not have the capability to deploy during this decade ABM defenses that could significantly alter the US-Soviet strategic nuclear relationship.<sup>23</sup>

64. Another alternative view holds that the following significant factors should be given greater weight in judging Soviet motivations for deployment of a widespread ABM defense:

- Soviet doctrinal requirements for damage-limiting capability have always provided the motivation to deploy ABMs both at Moscow and elsewhere. The Soviets' restraint in the early 1970s, as noted in paragraph 7, was driven by the overriding requirements to limit US ABM de-

<sup>22</sup> The holder of this view is the Assistant Chief of Staff for Intelligence, Department of the Army.

<sup>23</sup> The holder of this view is the Director, Bureau of Intelligence and Research, Department of State.

ployments to enable them to achieve a counterforce capability against undefended US ICBMs and by the Soviets' recognition that their systems were not then capable of adequate defense. Since then, however, important changes in the nature of both Soviet and US systems have occurred: Soviet ABM technology has evolved to a point where, as noted in paragraph 20, it is judged capable of defending against many kinds of ballistic missile RVs; the USSR has achieved a MIRV counterforce advantage; and the United States is planning to deploy survivable and hard-target-capable ballistic missiles. This view holds that, as a result the Soviets now may judge that the military advantage lies on the side of further ABM deployment and that restraining the United States through the ABM Treaty is no longer a military necessity.

- This view notes that the Soviets, in their criteria for judging adequacy of performance, consider effectiveness in the total context of their overall damage-limiting capabilities as part of their plan to fight and win a nuclear war. The holder of this view concludes that, while not providing a leak-proof defense, a widespread ABM deployment using present technology and systems under development, combined with passive defense measures and possibly augmented by SAMs performing in an ABM role, could satisfy the requirements of Soviet military strategy for limiting damage to critical targets in the USSR. Also, the Soviets would deploy sufficient numbers of ABM systems to enhance their confidence in the survival of high-value targets, even in the event of a full-scale US attack.
- The Soviets have taken essentially all the steps necessary to prepare for a decision to deploy. ABM radar and interceptor developments have proceeded to the point where deployments of viable systems is possible, and they are in the process of improving their network of long-range acquisition radars on the periphery of the Soviet Union. In this view the Soviet ABM system for widespread deployment appears to have the general features of a good ABM system design with the technical potential to engage all currently deployed types of US ballistic missile RVs. Moreover, confidence in current ABM technology is demonstrated by deployment of the new

ABM system at Moscow. [

]widespread ABM defense, the Soviets appear to have an adequate and expanding production base for such deployment. It is unlikely that they would have carried development and testing to the point they have without planning for the production base to support a deployment decision. Similarities between components of the rapidly deployable system and the new ABM defenses being installed at Moscow demonstrate that at least a partial production base already exists.

- This view—while certainly not precluding Soviet deployment of additional radars for redundant battle management support, possibly even large numbers with less sophistication than the peripheral radars—holds that they would not be necessary and at present there is no basis in evidence for them. In this view, large fixed acquisition radars, whether located in peripheral or interior regions of the Soviet Union, would have the same vulnerabilities.
- The Soviets may be expected to accompany any widespread ABM deployments with an active-measures campaign to manipulate Western attitudes and actions. They would attempt to lessen the impact of abandoning the ABM Treaty by focusing attention and blame on the United States and by taking action to inhibit energizing the United States and its Allies into sustaining a rapid growth in military capabilities. The Soviets may therefore perceive long-term military and political advantages as outweighing any short-term political disadvantages connected with a rapid widespread ABM deployment.

On balance, the holder of this view believes that the Soviets have prepared themselves, and may have sufficient motivation, to deploy ABMs beyond present Treaty limits. The decision for such deployment could be made at any time. By initiating a rapid deployment in the mid-1980s, the Soviets could confront the United States in a matter of a few years with Soviet ballistic missile defenses effective enough to create serious doubts about the credibility of the US nuclear deterrent. The holder of this view believes it is not possible with current intelligence data to evaluate and quantify with confidence the extent to which various factors would influence the Soviets to abandon or

retain the ABM Treaty. However, given the preparations the Soviets have made and the fact that the motivations discussed above strongly influence Soviet decisions, the main text may have understated the prospect for widespread ABM deployment.<sup>20</sup>

#### V. KEY UNCERTAINTIES

<sup>20</sup> The holder of this view is the Director, Defense Intelligence Agency.

#### DISSEMINATION NOTICE

1. This document was disseminated by the Directorate of Intelligence. This copy is for the information and use of the recipient and of persons under his or her jurisdiction on a need-to-know basis. Additional essential dissemination may be authorized by the following officials within their respective departments:

- a. Director, Bureau of Intelligence and Research, for the Department of State
- b. Director, Defense Intelligence Agency, for the Office of the Secretary of Defense and the organization of the Joint Chiefs of Staff
- c. Assistant Chief of Staff for Intelligence, for the Department of the Army
- d. Director of Naval Intelligence, for the Department of the Navy
- e. Assistant Chief of Staff, Intelligence, for the Department of the Air Force
- f. Director of Intelligence, for Headquarters, Marine Corps
- g. Deputy Assistant Secretary for International Intelligence Analysis, for the Department of Energy
- h. Assistant Director, FBI, for the Federal Bureau of Investigation
- i. Director of NSA, for the National Security Agency
- j. Special Assistant to the Secretary for National Security, for the Department of the Treasury
- k. The Deputy Director for Intelligence for any other Department or Agency

2. This document may be retained, or destroyed in accordance with applicable security regulations, or returned to the Directorate of Intelligence.

3. When this document is disseminated overseas, the overseas recipients may retain it for a period not in excess of one year. At the end of this period, the document should be destroyed or returned to the forwarding agency, or permission should be requested of the forwarding agency to retain it in accordance with IAC-D-69/2, 22 June 1953.

4. The title of this document when used separately from the text is unclassified.