

Executive Registry
80-2392

80-10-18

THOMAS J. KANE, JR.
vice president

GRUMMAN AEROSPACE
CORPORATION
BETHPAGE, NEW YORK 11714

October 23, 1980

Admiral Stansfield Turner, Director
Central Intelligence Agency
Washington, D.C. 20505

Dear Admiral Turner:

We have noted with interest your recent U.S. Naval Proceedings article on the future makeup of the United States surface fleet.

Enclosed are a brochure and two recent papers given by Grumman in advocacy of one possible future course of action based upon emerging technology.

It is basically a ship/surface-launched missile/aircraft system for which the ship is certainly feasible, missiles are existent with new types in R&D and the aircraft/conformal surveillance radar well underway in ground-based R&D. The next step is to build a technology research aircraft of the type illustrated, and, in parallel, flight test the conformal radar.

Should you wish to discuss the matter further, we would be most happy to do so. My telephone number is (516) 575-7400.

Yours very truly,



Thomas J. Kane, Jr.
Vice President -
Business Development

Enclosures

TJK/ap

001 31 5 21 1980

EB

001 31 5 21 1980

13

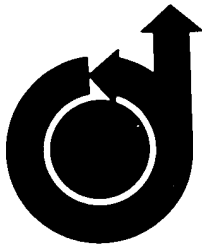

AIAA-80-1811

**Surface Combatant Fleet
Offensive/Defensive Enhancement
by High Performance
Turbofan VTOL Aircraft
R. W. Kress, Grumman
Aerospace Corp., Bethpage, N.Y.**

*Timing
Radar Perf
Time Dist intercept
Replace cv
LAMP3
On bd processing*

**AIAA AIRCRAFT
SYSTEMS MEETING**

August 4-6, 1980/Anaheim, California

SURFACE COMBATANT FLEET OFFENSIVE/DEFENSIVE ENHANCEMENT
BY HIGH PERFORMANCE TURBOFAN VTOL AIRCRAFT

Robert W. Kress*
Director of Advanced Concepts
Grumman Aerospace Corporation
Bethpage, New York 11714

Abstract

A new concept of naval air operations, involving surface combatants equipped with long range air/surface missiles, and ten small, high-altitude, high-speed and long-range surveillance/missile aircraft for targeting and attack, is described. Results of an affordability analysis of this concept are briefly presented. Grumman's Design 698 aircraft, conceived for this role, is described, and its basic compatibility with various ship classes is presented. The current status of the development program directed toward a Technology Demonstrator of the Design 698 concept is described.

Introduction

The content of this paper is addressed in Figure 1. It is important at the outset to stress that this paper does not concern itself with the role of VSTOL aircraft mixed in with the normal complement of carrier-borne aircraft, nor does it address a VSTOL ship concept which is either a replacement or supplement to existing carrier forces. What the paper does address is a new conceptual surface combatant class, which combines a ship with long-range missiles and high-performance turbofan aircraft. This ship has systems and mission roles which are distinct and additive to the carrier battle groups. In effect, this paper deals entirely with a conceptual change in the method of operations and capability of the naval surface forces other than the carriers.

- | |
|--|
| <ul style="list-style-type: none"> ● WILL NOT ADDRESS THE ROLE OF V/STOL AIRCRAFT ON CVs ● WILL NOT ADDRESS A V/STOL CARRIER CV REPLACEMENT OR SUPPLEMENT ● WILL ADDRESS A NEW CONCEPTUAL SURFACE COMBATANT CLASS WITH <ul style="list-style-type: none"> - LONG RANGE MISSILES AND - HIGH PERFORMANCE TURBOFAN AIRCRAFT <p style="text-align: center; margin: 5px 0;">HAVING</p> <ul style="list-style-type: none"> ● SYSTEMS AND MISSION ROLES DISTINCT AND ADDITIVE TO CV BATTLE GROUPS. |
|--|

Figure 1 Content of the Paper

The Concept

Figure 2 is an artist's rendition of the concept of a new class of surface combatant ship having aircraft and long-range missilery in a particular combination, such that there is a very substantial offensive and defensive capability enhancement of the ship class. The artist's concept shows an aircraft, Grumman's Design 698, which is envisioned to exist in two basic versions for this particular application; the first version being a surveillance/missile aircraft, and the second being a jammer aircraft. The complement of these aircraft envisioned for the ship in the artist's rendition is ten aircraft; eight of the surveillance/missile type and two jammers. The ship itself is in the 10,000 ton

* Associate Fellow, AIAA

Copyright © American Institute of Aeronautics and Astronautics, Inc., 1980. All rights reserved.

class, carrying a load-out of approximately 120 vertically launched, long range, surface-to-surface, surface-to-air, and surface-to-subsurface missilery. The ship is equipped with a rather large central hangar and a 250 ft. foredeck which can be used for vertical takeoff or short takeoff operations for payload enhancement. The afterdeck is approximately 150 ft. long and can be used for vertical takeoff and landing operations. It may also be equipped with a low energy barricade arrestment system for retrieving aircraft in a one-engine-failed situation. This avoids penalties associated with provision of excessive aircraft core engine power for vertical landings in the engine out case.

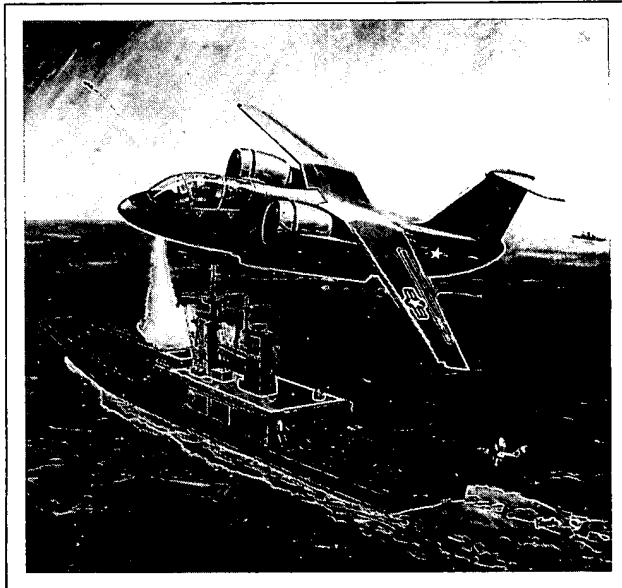

Figure 2 Design 698 VTOL Aircraft/DGV Ship Concept

The basic surveillance or jammer aircraft are designed such that, as VTO's, they have a very respectable level of performance, which will be shown later. In other words, these aircraft are fully capable with a vertical takeoff on a hot day. A good indicator of this is the 29% fuel fraction under those circumstances. A short STO run of 170 ft. with a mild ski jump, which is close to the natural bow contour of this size surface combatant ship, results in the capability of roughly a 3,000 lb. payload enhancement on a hot day, with 10 kts. wind over deck. This allows the aircraft to be fitted out with a pair of Harpoon air-to-surface weapons, or a pair of long range air-to-air weapons, or up to six AMRAAM-class weapons for closer in air-to-air applications, or four advanced lightweight torpedos for long range ASW "Pouncer" operations.

Grumman has been working very closely with Litton-Ingalls in the design and integration of this ship class with the Design 698 aircraft. The Design 698 aircraft described is basically an aircraft in the 20,000 lb. takeoff gross weight category having a crew of two. The avionics systems envisioned for

this aircraft employ the most modern surveillance radar, jammer, and control and display technology expected to be available at the time of aircraft fleet introduction. All systems are under development.

Figure 3 is a brief illustration of the Soviet naval force trends which form the underlying basis for the thought process leading to consideration of this new concept of operations. We have seen the emergence of Kiev-class VSTOL carriers equipped with the Forger supersonic fighter-attack aircraft. We have seen increasing numbers of Soviet surface combatants which appear to be in an almost continuous mode of shadowing U.S. fleet elements. We are faced now with the emerging threat of the Backfire naval land-based aircraft with long range air-to-surface missiles. Throughout the design of these Soviet fleet elements runs a central thread which is an emphasis on long-range missilery from all sorts of platforms; surface, subsurface, and air. In the future, but beginning to be dimly perceived, are such ships as 30,000 ton class nuclear battle cruisers and 80,000 ton carriers. Faced with this threat, one must take a hard look at one's own status, which is basically shown in Figure 4.

- EMERGENCE OF KIEV V/STOL CARRIERS
 - FORGER SUPERSONIC FIGHTER/ATTACK
- INCREASING NUMBERS OF SURFACE COMBATANTS
- BACKFIRE NAVAL LAND-BASED AIRCRAFT
- INCREASING SUB FLEET
- EMPHASIS ON LONG RANGE MISSILES FROM ALL PLATFORMS
 - ASMs, SURFACE & SUBSURFACE LAUNCHED SSMs
- LARGE NEW COMBATANTS
 - 30,000 TON NUCLEAR BATTLE CRUISER
 - 80,000 TON CARRIER?

Figure 3 Soviet Naval Force Trends

- | | | |
|--|-------|-------|
| | 1968 | 1990 |
| ● DIMINISHING NUMBER OF AIRCRAFT CARRIERS | (23) | (13) |
| ● DIMINISHING NUMBER OF SURFACE COMBATANTS | (314) | (212) |
| - ORIENTED MORE TOWARDS DEFENSIVE RATHER THAN OFFENSIVE ROLES: i.e. ASW, AAW RATHER THAN ASUW, SKW | | |
| ● INCREASED DEMANDS/NEEDS | | |
| - FOR MORE GLOBAL PRESENCE, i.e. INDIAN OCEAN, SOUTH ATLANTIC | | |
| - FOR BROADER WARTIME MISSIONS | | |
| * ESCORT: CONVOYS, AMPHIB, AND UNDERWAY REPLENISHMENT GROUPS | | |
| * POWER PROJECTION | | |
| * DEFENSE OF OIL ROUTES: TANKER PROTECTION | | |
| ● BECOMING MORE VULNERABLE, AS SOVIET SEA & LAND BASED NAVAL CAPABILITIES IMPROVE, TO | | |
| - COORDINATED PREEMPTIVE MISSILE STRIKES BY | | |
| * SUBMARINES | | |
| * SURFACE SHIPS | | |
| * AIRCRAFT, BOTH SEA BASED AND LONG RANGE BACKFIRES | | |
| - COORDINATED SUBMARINE & AIR ATTACKS AGAINST | | |
| * CONVOYS | | |
| * OIL TANKERS | | |

Figure 4 U.S. Naval Force Trends

Using 1968 as the year of reference, we see that the number of our aircraft carriers has diminished from 23 in 1968 to 13 in 1980. A historical note shows that at the conclusion of World War II the United States had 105 aircraft carriers in commission. Similarly, we are faced with a diminishing number of surface combatants from 314 in 1968 to 212 in 1980. Furthermore, the roles of these surface combatants has, in recent history, been oriented more towards defensive rather than offensive operations.

Meanwhile, the U.S. naval fleet, in the face of diminishing carrier and surface combatant assets, is presented with increased needs and demands for global presence, and a broader spectrum of wartime missions throughout the world. Coupled with this is the fact that they are becoming more vulnerable to Soviet sea and land based threats, and most importantly, they are faced with the possibility of a preemptory, concentrated, coordinated Soviet missile strike.

Figure 5 briefly summarizes some fundamental limitations of the United States fleet under its current makeup. First of all, the carrier provides the only major fleet offensive capability and there are a limited number, at best, at sea at any given time. For its defense against major enemy missile attacks, it is dependent upon the Aegis cruiser and its radar and defensive missile systems. The Aegis cruiser with no over-the-horizon detection capability due to the line-of-sight limitations of its ship-based radar is dependent upon carrier air assets in the form of the E2C for over-the-horizon information. Therefore, with the present fleet composition, the concept of an autonomous non-carrier surface action or escort group may simply not be feasible, due to the lack of effective air coverage. Such an autonomous non-carrier surface action group might or might not involve the use of Aegis cruisers, but in any case, to be survivable, a group would have to have adequate air coverage.

- CV PROVIDES ONLY MAJOR FLEET OFFENSIVE CAPABILITY; LIMITED NUMBER AT SEA
- AUTONOMOUS NON-CV SURFACE ACTION AND ESCORT GROUPS MAY NOT BE SURVIVABLE DUE TO LACK OF EFFECTIVE AIR COVERAGE.

Figure 5 U.S. Fleet Limitations

Turning now to Figure 6, we will begin to elaborate on the key ingredients of the concept presented in this paper. The first ingredient, of course, is to develop a subsonic, high-speed, high-altitude, long-range turbofan VTOL aircraft for the surface combatants. We will return to this topic later in the paper, which is really the central issue. As was mentioned earlier, the basic concept consists of the marriage of a ship, long-range missilery and a turbofan high-performance aircraft to form an autonomous ship capability. The only ingredient of that combination which remains to be set into motion from a development point of view is the aircraft.

- SUBSONIC, HIGH SPEED, HIGH ALTITUDE, LONG RANGE TURBOFAN VTOL AIRCRAFT FOR SURFACE COMBATANTS
- PRIMARY VERSIONS:
 - AEW/MISSILEER
 - EW JAMMER
 - DISTRIBUTED vs. POINT SENSOR CONCEPT
 - ALLOWS SHIP EMCON
- OTHER VERSIONS:
 - ASW "POUNCER"
 - OV-X OVERLAND TARGETING
- COMBINE WITH SHIP-BASED VERTICAL LAUNCH MISSILES TO ALLOW AUTONOMOUS NON-CV SURFACE ACTION AND ESCORT GROUPS
- MISSILEER CAPABILITY COMPOUNDS THREAT TO ENEMY
- EXPLORE A SHIP CLASS MATCHED TO THE AIRCRAFT: "DGV"
 - DD 963 HULL
 - 10 AIRCRAFT
 - 250 FT. FOREDECK FOR STOL LAUNCH OVERLOADS
 - 150 FT. AFTERDECK FOR SINGLE ENGINE OUT BARRICADE ARRESTMENTS
 - 120 VERTICAL LAUNCH TUBES

Figure 6 The Key Ingredients of the Concept

The concept of the aircraft involves two primary versions: an AEW version, designed to operate with full capability with a vertical takeoff on a hot day, and with a short 170 ft. takeoff from the foredeck of the vessel, can be loaded with a full complement of either air-to-air or air-to-surface missiles; the other primary version of the aircraft is envisioned to be an electronic warfare or jammer version which is very effective in coping with air threats. In effect then, what has happened in comparison, for instance, to a ship-based radar system is that the point sensor in the form of the ship's radar has been supplemented by the distributed sensors carried by the aircraft. This has one very valuable fall-out, that is, it allows the ship to run quiet or on EMCOM, which makes the detection of the ship, from an enemy point of view, very much more difficult.

There are other versions of the aircraft which are envisioned. In our scenario work done under contract to the Navy, a variant of the airplane called an ASW "Pouncer" was found to be very useful. For instance, a maritime patrol aircraft might have several submarine contacts existent at one time. If the patrol aircraft chose to prosecute one of these contacts, it would of course lose the other contacts. Under these circumstances, it would be highly desirable to call in a fast aircraft to prosecute the attack so that the patrol aircraft could hold all of its contacts while the attack was underway. Of course, this role as envisioned is in no way competitive with the LAMPS helicopter, which is a closer-in device with a much more substantial payload in the form of onboard ASW equipment.

Another version of the aircraft envisioned as being highly desirable is one carrying a system of sensors which would be useful for overland targeting. Such sensors would take the form of battlefield radar for detecting small moving targets, plus signal

monitoring equipment for determining emitter locations. This version of the airplane would be used in combination with ship-based missilery, wherein missiles would be fired at long range and their guidance updates performed by the aircraft.

All of the roles of the combined aircraft/ship/missile system can be performed by ship-launched weaponry guided via the aircraft over the horizon. However, the existence of a missileer capability in the aircraft provides an additional element, which greatly compounds the threat to the enemy in that offensive weapons against his surface units or air units can now come from many directions simultaneously. Furthermore, in the case of attacks against enemy units, be they surface ships or aircraft, there are certain occasions when one cannot afford the transit time of the ship-launched weapon to a particular target.

The ship which is currently envisioned and matched to the aircraft, we have dubbed DGV, standing for Destroyer, Guided Missile, Vertical Takeoff Aircraft. Our investigations to date have been conducted with the help of Litton-Ingalls Shipbuilding and have been based upon utilization of variants of the DD-963 Spruance-class destroyer hull and machinery. At this time we envision a hangar capable of comfortably berthing 10 of the 20,000 lb. class Design 698 aircraft. With the 250 ft. foredeck for STOL missileer overloads and a 150 ft. afterdeck for single-engine-out barricade arrestments, and having 120 vertical launch tubes, the basic configuration details of this ship have been fairly thoroughly investigated. The ship turns out to be in the 10,000 ton class, and more will be said about it at a later point in the paper.

Figure 7 is a pictorial comparison of today's surface combatant operational concept vs. tomorrow's concept of operations just described. With today's

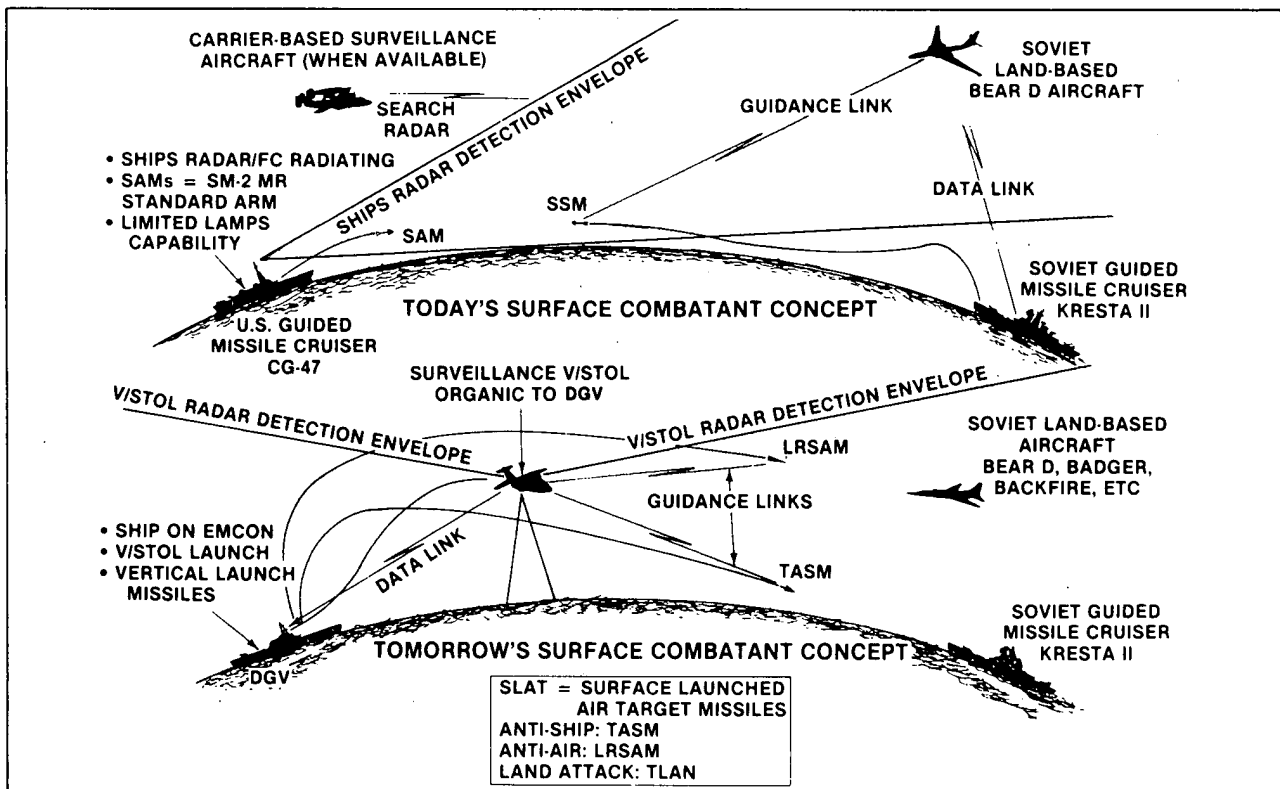

Figure 7 New Surveillance/Fire Control Concept for DGV Surface Combatant

operations one would have, for instance, an Aegis guided missile cruiser of the CG-47 class, using its point source radar for detection of enemy surface and air units. It would be equipped with anti-radiation missiles and surface-to-air missilery. It would have an ASW capability in the form of the LAMPS helicopter, and it would work in concert with carrier-based surveillance aircraft when available. This system, of course, is line-of-sight limited. Without carrier assets, the line-of-sight limitations make offensive operations against enemy surface and low-altitude air units at long ranges impractical, and place greater demands on the ship's defensive systems against low-flying cruise missiles. With the new concept of operations, using the vertical takeoff aircraft, the ship can run in EMCON and launch missiles, the guidance of which is performed at long ranges by the VTOL aircraft against either surface or air targets. The kinds of roles and missions envisioned for this DGV class of ship with its missiles and aircraft are illustrated in Figure 8.

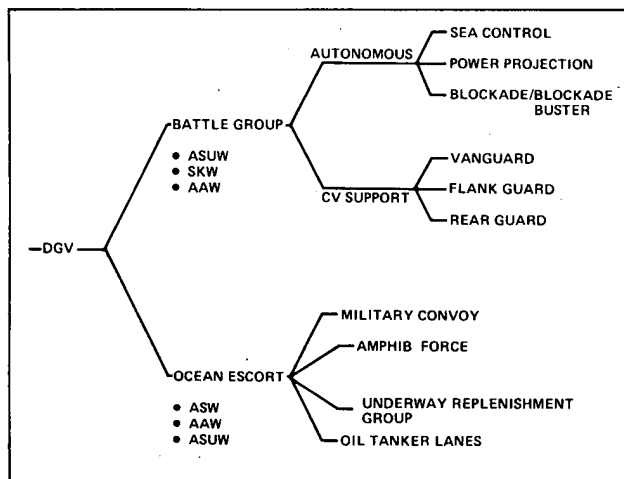

Figure 8 Missions/Roles for DGV Battle/Escort Groups

For instance, it could operate in support of a major carrier battle group, either as an integral element of the carrier group for vanguard, flank guard, or rear guard operations, or it could split off with other cruisers and destroyers as an autonomous element for sea control, power projection, or blockade roles. This sort of support of a carrier group would have many fundamental advantages in that the power of the group would be divisible to meet situational requirements, and the overall surveillance capability of the group would be substantially enhanced. The other mode of operation of the DGV envisioned is with frigates as an escort for convoys, amphibious, task groups, underway replenishment groups, or in the tanker lanes. In work which will be displayed later, we currently envision that the Navy could afford something on the order of 30 of these DGV's for the roles envisioned in Figure 8.

Figure 9 presents the overall operational concept of the system, the elements of which have just been described. What emerges is an offensive and defensive capability for operations of ship groups not under a carrier air umbrella. These groups would have a defensive capability vs. the Backfire in the form of long-range detection of the aircraft and attack of those aircraft, either via long-range, ship-launched, air-guided missiles or air-launched missiles from the missileers. This capability not only covers the aircraft but also extends to cruise missiles which are easily detected by the airborne radar, and can be attacked by ship-based air-guided missilery, air-

launched missiles from the missileers or ship-based, ship-controlled missiles. It is important to note that the capability to detect and attack a cruise missile from one platform, as the missileer version can, does not exist in the fleet air units today.

- **AUTONOMOUS OFFENSIVE/DEFENSIVE OPS OF SHIP GROUPS NOT UNDER CV UMBRELLA**
- **DEFENSIVE VS. BACKFIRE THREAT**
 - AEW/MISSILEER VERSION FOR LONG-RANGE DETECTION AND ATTACK OF BACKFIRES AND CRUISE MISSILES WITH SLAT & AIR-TO-AIR MISSILES
 - JAMMER VERSION TO SCREEN SHIPS
 - LONG-RANGE CRUISE MISSILE DETECTION AND ATTACK CAPABILITY
- **DEFENSIVE AND OFFENSIVE VS. ENEMY SURFACE/SUB-UNITS AND LAND TARGETS**
 - AEW/MISSILEER VERSION FOR DETECTION, IDENTIFICATION AND ATTACK. SLAT TOMAHAWK TO 500 N MI
 - AUTONOMOUS CARRIAGE OF HARPOONS FOR HIGH ELECTRONIC CONFUSION ENVIRONMENT - OR QUICK SUB REACTION
- **ASW: COMPLEMENTARY TO LAMPS III, "POUNCER"**
 - LONG RANGE
 - HIGH SPEED
 - NEEDS ADVANCED LIGHTWEIGHT ASW SYSTEMS
- **ENHANCED IN MOST ROLES BY MPA INTERACTION**
 - LOWER MPA REQUIREMENTS AND VULNERABILITY IN SEA LANE DEFENSE ROLES.

Figure 9 Subsonic Turbofan V/STOL Operation Concept

The function of the jammer version of the aircraft is to provide a defensive screen for the surface ships to force the Backfire aircraft in closer to the ships, where they can be handled more easily by the aircraft and ship-launched weaponry.

In the area of mounting offensive operations against enemy surface or submarine units, the surveillance/missileer version is used for the detection and identification of those units, and either surface-launched, air targeted Tomahawks or air-launched Harpoon missiles can be used. The air-launched missiles are most valuable in high-ECM environments and for quick reaction strikes at extreme ranges where the fly-out time of the Tomahawk is excessive.

Control of the operations can be vested either in the ship or in the aircraft, depending upon the demands of the particular occasion. In general, the ship commander would prefer to have situation reporting from the aircraft, which involves a transmission of data and fairly complicated message traffic. However, under certain circumstances, there is an advantage to having the control of the situation vested in the aircraft where the aircraft commander can either call for surfaced-launched weaponry, or use his own weaponry to mount an attack. This sort of situation could develop when the airplane commander ran into a situation demanding immediate action with enormous advantage to his forces without the time lags inherent in the message traffic and the returned-command orders. Basically, in a situation where the aircraft commander is in control, the only command required to be sent back to the ship would be a fire signal to launch a missile on a particular heading and have guidance taken over by the aircraft.

I have already described the operation of the ASW Pouncer aircraft, which is really a system complementary to the LAMPS III system which is presently coming into service. The Pouncer, of course, capitalizes on its long range and high speed to prosecute submarine contacts coming from either air units

or surface units. In order to increase the effectiveness of such an aircraft, advanced, lighter-weight ASW systems would be highly desirable. In the case of the interaction of the various aircraft types with maritime patrol aircraft, our scenarios have tended to indicate that the maritime patrol aircraft capability requirements are dramatically reduced by the existence of the VTOL aircraft in support of the maritime patrol aircraft. The vulnerability of the maritime patrol aircraft in sealane defense roles is also greatly reduced by the presence of the VTOL.

Turning now to Figure 10A, we see typical Atlantic operations of a number of naval groups. In the North Atlantic there is a carrier battle group having a very substantial and effective defense zone against Backfire aircraft threats, by virtue of the long range detection capability of the E-2 and the combat air patrol and Phoenix missile capability of the F-14 fighters. Other parts of Figure 10A show an underway replenishment group, an amphibious group, a surface-action group, and a convoy group, all of which have protection against Backfire aircraft only in the form of the inner defense zones provided by the surface-to-air missiles guided to their target by ship-borne radars.

Looking now at Figure 10B, we have shown the vulnerability zones of the underway replenishment group, the amphibious group, the surface-action group, and the convoy group to Backfire antiship missiles (ASMS). These missile launch zones are substantially beyond the capability of the point defense surface-to-air missile systems of the groups, and saturation attacks would doubtless have a devastating effect.

Finally, referring to Figure 10C, one sees the effect of adding to each of these four vulnerable groups a single DGV ship with its air complement. It is seen that the addition of this ship provides effective defense against a Backfire threat over a perimeter which, while not as large as that of the carrier battle group, is still sufficient to be effective.

Figure 11 addresses the major steps in implementation of the concept of operations just described. Step 1 would be to demonstrate that such a turboprop VTOL aircraft can in fact be built and effectively operated in the types of missions described. This has been the major objective of Grumman for some time, and is in fact the major point of this paper. The second step is to demonstrate the aircraft conformal surveillance radar which forms such a key element of the surveillance/missile aircraft system. Fortunately, this development and the ensuing demonstration are well under way at Grumman under vigorous Navy funding. Demonstration of the DGV ship concept would be a natural follow-up to the availability of the turboprop VTOL aircraft demonstrator. Sea trials of both the ship roll stabilization required for aircraft operations for the DGV and the guidance and control concepts inherent in matching the aircraft motion to the ship motion in heavy seas, from a vertical motion point of view, would be a fallout of this exercise.

Looking beyond the period of demonstration of the viability of the aircraft and ship concept and their matching, one would then address the acquisition programs required to put the system into naval operation. In the ship area, current naval thinking calls for acquisition of approximately 50 DDGX's, or

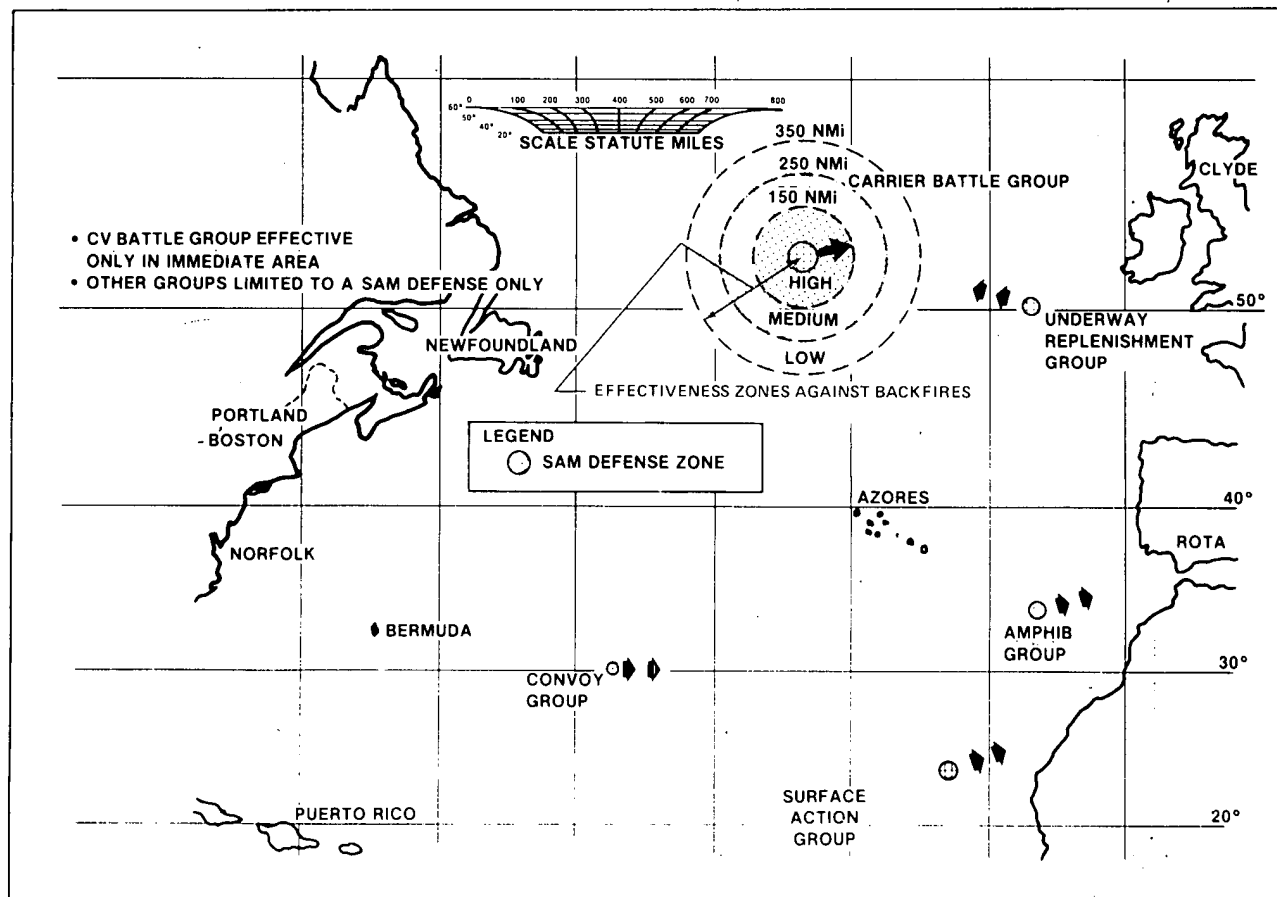

Figure 10A Today's Operations

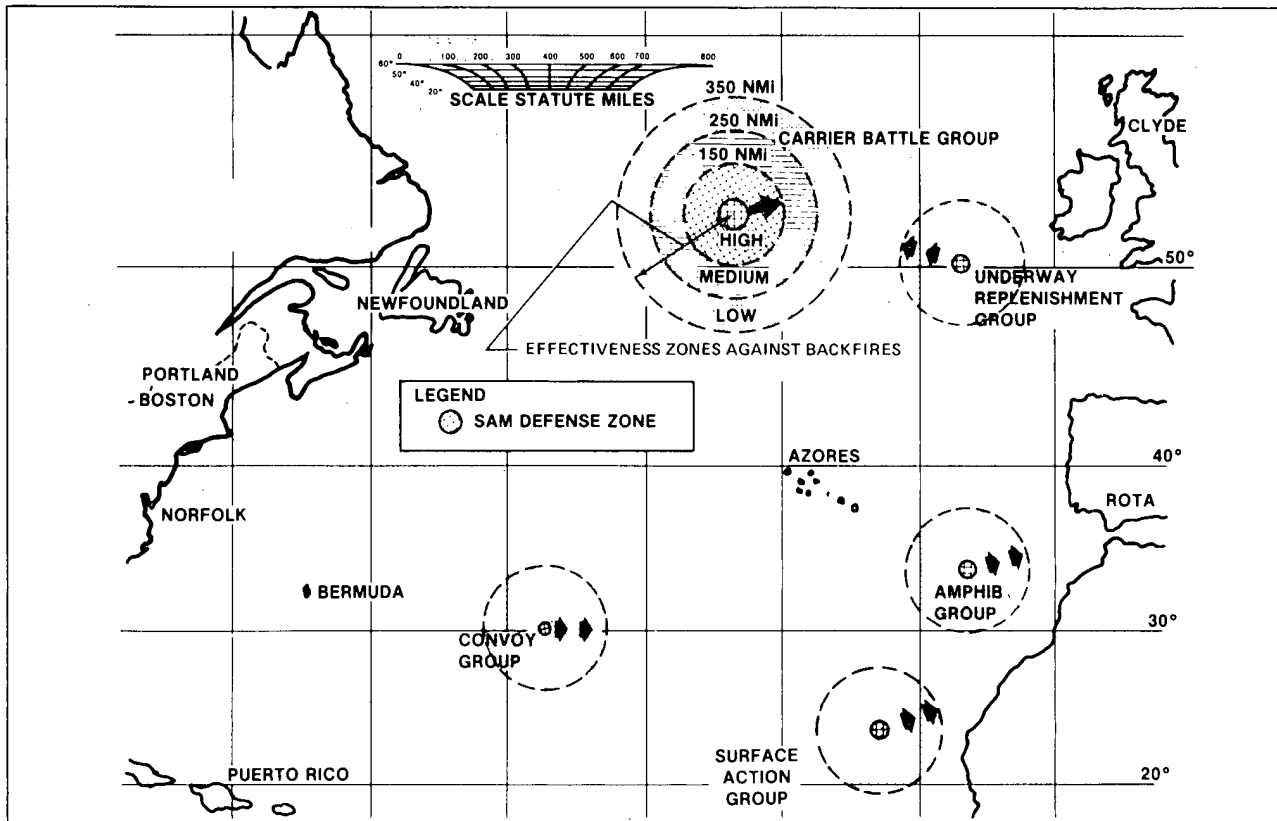

Figure 10B Backfire Launch Zones

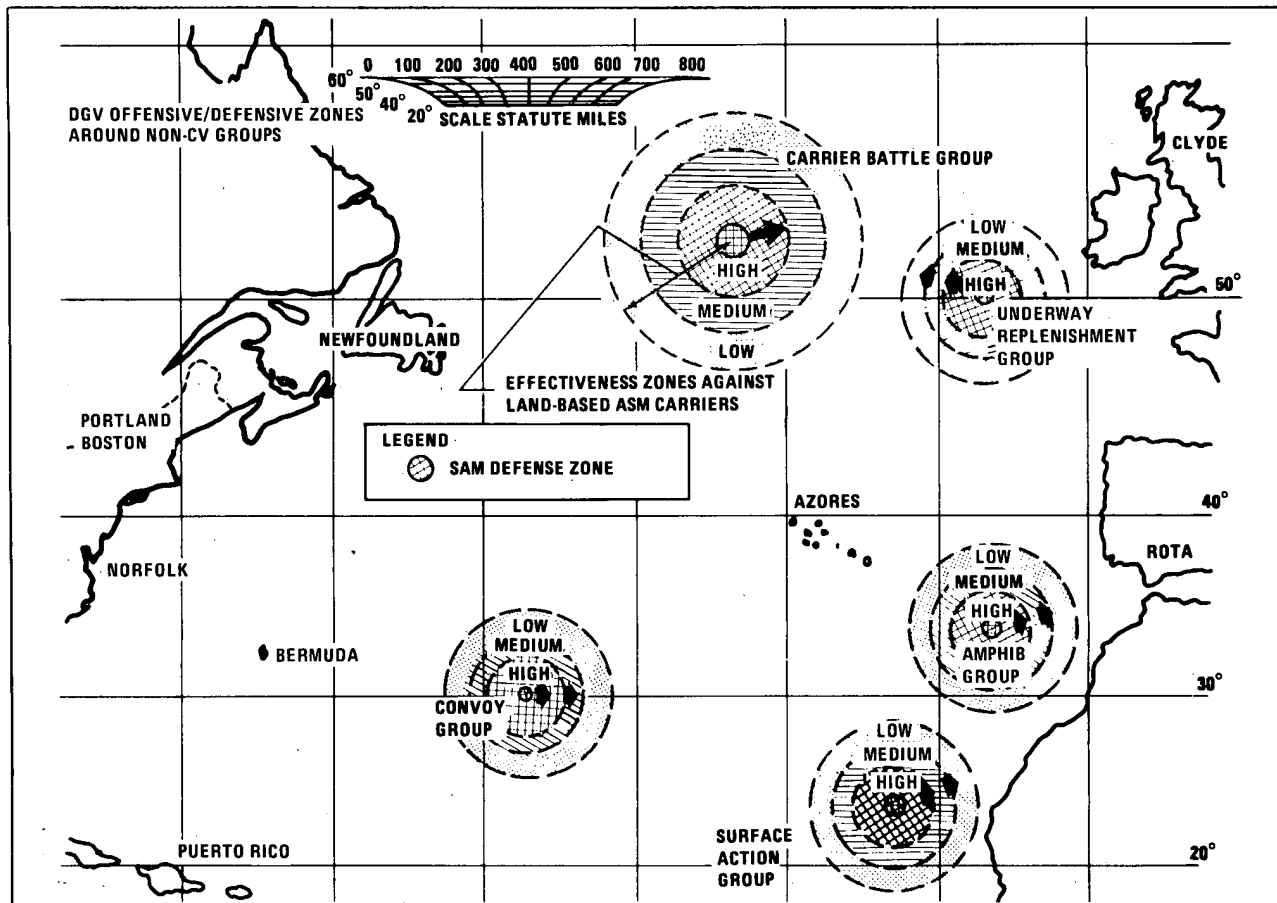

Figure 10C DGV Offensive/Defensive Zones Around Non-CV Groups

Guided Missile Destroyers. Implementation of the concept described herein could be accomplished by acquisition of 18 DDGX's and 28 of the DGV's, as opposed to 50 of the DDGX's. In the aircraft area, acquisition of 410 of the VTOL aircraft is envisioned. What may appear somewhat surprising is that acquisition of an additional 190 LAMPS III helos would be required for ASW coverage of the additional autonomous fleet groups created by addition of the DGV's. Lastly, acquisition of additional vertically launched missiles would be required to fill out the expanded capability inherent in the DGV ship concept.

- DEMONSTRATION**
- DEMONSTRATE TURBOFAN VTOL AIRCRAFT CONCEPTUALLY
 - DEMONSTRATE AIRCRAFT CONFORMAL SURVEILLANCE RADAR
 - DEMONSTRATE THE DGV & CONDUCT AIRCRAFT SEA TRIALS.
- ACQUISITION**
- ACQUIRE 18 DDGX'S & 28 DGVs vs. 50 DDGXs
 - ACQUIRE 410 VTOL AIRCRAFT
 - ACQUIRE 190 ADDITIONAL LAMPS III HELDS FOR ASW COVERAGE OF THE ADDITIONAL AUTONOMOUS FLEET GROUPS CREATED BY ADDITION OF THE DGVs
 - ACQUIRE ADDITIONAL VERTICAL LAUNCHED MISSILES.

Figure 11 Major Steps in Implementing the Concept

Perhaps the most important aspect of this concept is briefly addressed in Figure 12, which is the affordability of the concept. Basically, what has been done at Grumman is to define a baseline Navy from a variety of sources of information, then to construct an alternative Navy along the lines of the information previously presented, and then to cost both out using various commonly recognized cost models. The total cost of the ships, aircraft, and weaponry for both the baseline and alternative surface combatant Navy concepts has been established in a rather extensive cost study at Grumman. The outcome of the study was that by introduction of the DGV, one could create 28 autonomous surface action and escort groups, each of which was centered about a DGV. The naval ship acquisition program would be almost the same in the baseline vs. the alternative case, with the alternative case involving acquisition of only four less surface combatants. What was found was that including the ships, aircraft, and missiles, one could acquire this new naval concept for the same fundamental cost as the baseline case. Figure 12 only contains the outcome of the study; presentation of the details of the study are beyond the scope of this paper.

- 28 AUTONOMOUS SURFACE ACTION AND ESCORT GROUPS CREATED CENTERED AROUND DGVs
- 4 LESS SURFACE COMBATANT SHIPS ACQUIRED.
- EQUAL COST OPTION INCLUDES:
 - SHIPS
 - AIRCRAFT
 - MISSILES.

Figure 12 Affordability of the Concept

The Aircraft

Having presented the overall concept of the integration of the aircraft with the ship and the surface-launched, air-targeted missiles, it is now appropriate to present more information on the kind of aircraft envisioned for the roles involved.

Figure 13 tabulates the desired performance and desired characteristics of a high performance aircraft for the surface combatant aviation roles envisioned. In the top half of Figure 13, five roles are defined. For each of these roles, the desired performance in general terms is called out; speed, altitude, long range and remote station loiter. Certainly, if the role envisioned for the aircraft involves a lot of hovering or very heavy load carrying capability for short ranges, the obvious choice would be a helicopter, but for the roles that we envision as being critical to the surface combatant, aside from ASW, which is the responsibility of LAMPS, the performance illustrated in the matrix is appropriate. In addition to the performance characteristics noted, other desired characteristics are that the airplane should be small for small-ship basing, and that they should be numerous in order to provide better ocean surveillance coverage. In addition, it would be highly desirable if a substantial non-Navy acquisition base potential existed, perhaps for the other services or for foreign Navies.

ROLES	DESIRED PERFORMANCE			
	HIGH SPEED	HIGH ALTITUDE	LONG RANGE	REMOTE STATION LOITER
● SURVEILLANCE (OVER WATER)		X		X
● TARGETING: AAW & ASUW	X	X	X	
● AUTONOMOUS MISSILEER; AAW & ASUW	X		X	X
● JAMMER	X	X	X	
● SURVEILLANCE & TARGETING (LAND TARGETS)	X	X	X	
DESIRED CHARACTERISTICS				
● SMALL: SMALL SHIP BASING				
● NUMEROUS				
- COVERAGE				
- ACQUISITION BASE				
● LARGE NON-USN ACQUISITION BASE POTENTIAL				
- OTHER SERVICES				
- FOREIGN				

Figure 13 Potential Surface Combatant Subsonic High Altitude/Speed Aircraft and Desired Characteristics

Figure 14 illustrates Grumman's Design 698 aircraft concept. Basically, the aircraft is a twin tilt-nacelle airplane, which is controlled through transition and hover primarily by means of horizontal and vertical vanes located in the turbofan slipstream. The airplane is of otherwise conventional arrangement with one exception. Airplane designers as a whole have gotten used to nose wheel type tricycle landing gear arrangements. For this airplane we have reverted to a dual forward landing gear configuration. This turned out to be overwhelmingly preferable for turnover stability on small decks wherein rolling motions of the ship could be expected. For a given landing gear tread, a much higher turnover stability could be achieved. Furthermore, since the airplane in its STOL mode does not require rotation for take-off with the fixed nacelle incidence, the tail wheel could be counted upon for the steering function.

Further elaboration on the key features of our Design 698 is presented in Figure 15. Of course, the keynote of the design is simplicity. The simplicity is obtained primarily through the fact that all VTOL equipment is located within the engine nacelles, (that is, provisions for thrust, modulation of thrust,

and control of the aircraft). In the capability of hovering in the event of a single engine failure is required, a backup cross shaft can readily be provided which is straight shaft between two right-angle gear boxes in the turbofans. This shaft is housed in the cross-box structure which links the two engine packages together into what we have called a "dumbbell" assembly. For military applications, one could consider operations without the cross shaft in the event of an engine failure, for reasons which will be discussed shortly. The aircraft has excellent visibility due to the shape of the nose, which is not in any way compromised by the presence of VTOL-related equipment. In fact, the entire airframe is completely free of VTOL provisions.

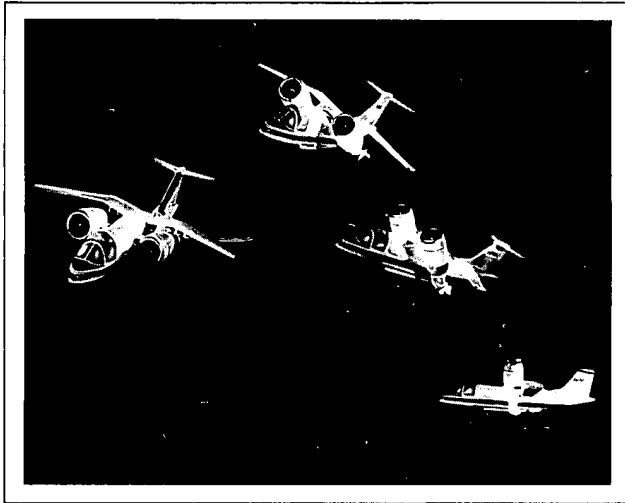

Figure 14 Design 698 in Takeoff/Transition Sequence

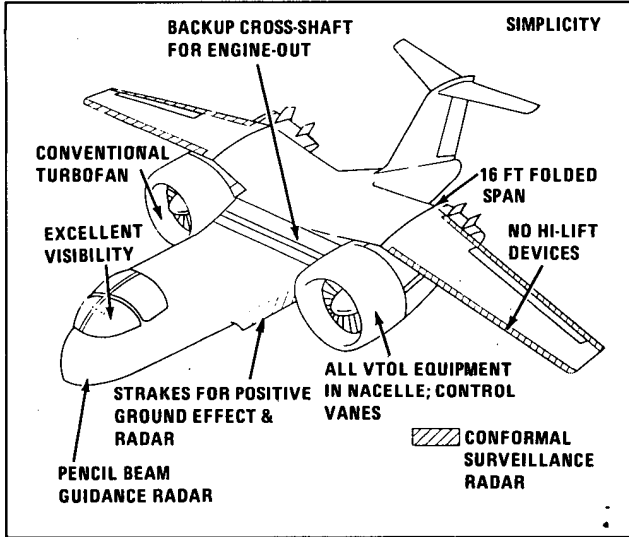

Figure 15 Features of Design 698

The major element of the aircraft, from a systems point of view, is the conformal surveillance radar which is housed in the leading and trailing edges of the wings and in the two fuselage strakes which are also provided to give positive ground effect. These six arrays provide 360 degree surveillance coverage about the aircraft, and have an excellent detection capability against the spectrum of air and surface targets, as well as being flush assemblies of a very low weight. For missile guidance, a small pencil beam-X-band guidance radar is provided, which works in consonance with the confor-

mal arrays for guidance of weaponry against both air and surface targets.

Figure 16 provides more detailed information on control of the aircraft in the hover mode. Addressing first pitch control, we see that there are a pair of vanes in the turbofan exhaust located below the center of gravity. Pitch control of the aircraft is provided by symmetrical deflection of these vanes. Similarly, differential deflection of these vanes produces yaw control of the aircraft. For roll control, we have provided both vertical vanes in the fan blast and variable inlet guide vanes. Approximately 50% of the roll control comes from each source. The major benefit of this kind of a system is that the thrust modulation of the engine for roll control is reduced from roughly plus or minus 20% of maximum thrust to plus or minus 10% of maximum thrust by use of the vertical vanes. This results in a significant reduction in the fan diameter requirements and weight of the power-plant package.

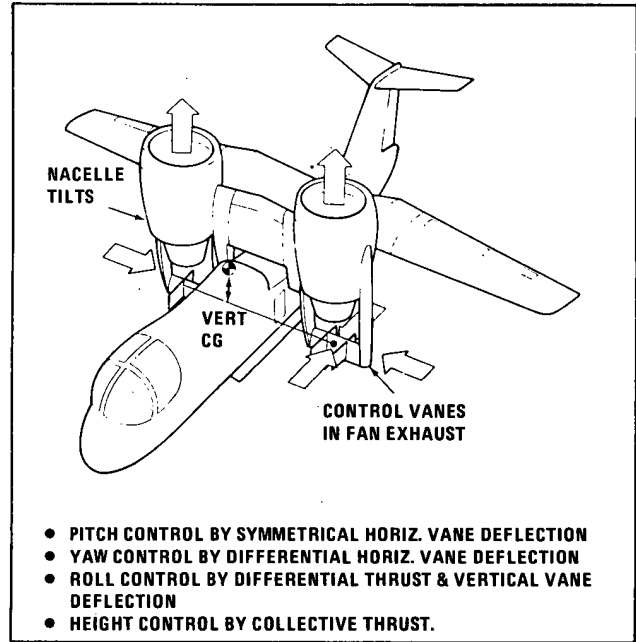

Figure 16 Vertical Flight Control

A second function of the variable inlet guide vanes is to stabilize the aircraft in roll in the event of an engine failure, for a configuration not employing a cross-shaft. Such might be used for military applications. For even extremely sudden or catastrophic fan failures, it is possible to very rapidly kill the thrust on the other side of the aircraft by shutting the variable inlet guide vanes completely; literally stuffing a cork in the live engine. This gives the crew adequate time for ejection. The subject of whether or not removal of the cross shaft is advisable for military applications has arisen fairly recently in order to reduce the cost and complexity of the aircraft. It may turn out to be a very logical thing to do, considering the fact that the overall probability of failure during a hover period of one of the two turbofans may be more operationally acceptable than the reduction in reliability introduced by the cross shaft assembly itself.

Perhaps the most important feature of the Design 698 aircraft is that it utilizes a conventional high bypass turbofan engine (bypass of approximately 6:1) used in virtually all modern commercial transports and also in the S-3 and A-10 military aircraft. The engines in this class are characterized

by their excellent cruise efficiency and their high static thrust. The TF34 engine is shown in Figure 17. Two of the A-10 TF34-100's are currently being used to power the full scale model of Design 698 in the 40 ft. x 80 ft. full scale tunnel test and the outdoor static testing to follow. As will be seen later, our ultimate intent is to build a technology demonstrator of Design 698 in exactly the same size as the wind tunnel model, using a pair of A-10 TF34 engines modified to accept inlet guide vanes and a digital fuel control. Basically, these are the only modifications required. Utilization of a slightly modified TF34 engine for the technology demonstrator is the key to being able to offer this program at low cost.

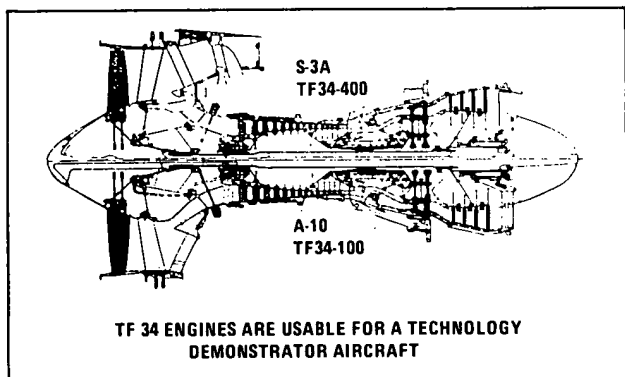

Figure 17 Design 698 Uses a Conventional Hi-Bypass Turbofan Engine Adapted to V/STOL

It should be noted that a vigorous program of variable-inlet-guide-vane technology demonstration for the TF34 engine is currently under way at NASA Lewis using a full scale TF34 engine.

The projected performance of the surveillance version of Design 698 is presented in Figure 18. This figure involves a very substantial upgrade of the TF34 engine. However, there is little disagreement about whether or not the technology levels are achievable in the time frame in which such an aircraft would become operational. The upgrade of the engine was defined working in cooperation with General Electric. In the case of this aircraft, we used the same sort of short-lift ratings typical of the Pegasus engine in definition of the allowable takeoff gross weight. The aircraft had a crew of two, with an overall mission load of 3,220 lb. and a fuel allowable of 6,814 lb. for a tropical day takeoff. This results in a fuel fraction of 29.2%, which is very respectable and provides excellent mission performance, considering the rather good specific fuel consumption characteristic of the high-bypass turbofan. The maximum Mach number is 0.8, the cruise Mach number is 0.59, and the aircraft has a time on station at 100 nautical miles of 3.65 hours. Ceiling of the aircraft is 50,000 ft. It should be noted that while we frequently hear cries of anguish about the "VTOL penalty", such penalty takes the form of oversized engines, which is not all bad. Figure 18 indicates that the sea level rate of climb of this aircraft is nearly 15,000 ft. per minute, which is better than the Harrier, although, of course, at the higher Mach numbers the high-bypass-ratio fan begins to fade compared to the lower-bypass class of the AV-8.

Figure 19 summarizes other applications of this 20,000 lb. class, subsonic turbofan VSTOL envisioned by Grumman. Basically, we see a large acquisition

base potential for versions of the aircraft which we have designated the OV-X, or the battlefield surveillance aircraft. We forecast interest developing in both the Army and Marine Corps. Foreign navies are developing and building VSTOL carriers, and we envision a rather large market in these navies for this class of aircraft. Eventually, we feel that the benefits of a commercial or executive VTOL transport in the nine-passenger class, which is the class of this aircraft (Cessna Citation, etc.), will be enthusiastically received. We think that the availability of an aircraft that can takeoff and land in confined areas like a helicopter, and still have a range of 1,200 nautical miles with comfort and low vibration levels, will prove to be of great interest to this market. Oil rig transport is a big factor in helicopter operations today, and we feel that this airplane, with its high block speed and comfort, will eventually come to replace a substantial part of the helo fleet currently in operation for these tasks. Another emergent role which may seem somewhat surprising is the search and rescue role. Recent discussions with experts in this field indicate that the prime requirement for a combat search and rescue aircraft may very well be to go along with raids against hostile territory, such as in Viet Nam, and to be prepared to rescue downed aviators through air pickups. These become straightforward with the VTOL aircraft, as opposed to letting the aviator go down into the ocean beyond the range of helicopters, which was a big problem in Viet Nam. The possibility of land pickups of downed aviators also becomes much more plausible with this class of airplane. In the search and rescue regard, Air Force interest may well evolve.

	DES 698
TOGW (TROPIC DAY, VTO SHORT LIFT)*	23,269
MISSION-LOAD/FRACTION	3220/0.138
FUEL/FRACTION	6814/0.292
M _{MAX}	0.80
M _{CR}	0.59
RAD (TOS = 0), N MI	705
TOS AT 100 N MI, HR	3.65
CEILING, FT	50,000
R/C @ SL, FPM	14,850

* PEGASUS-TYPE SHORT LIFT ENGINE RATING PHILOSOPHY

Figure 18 Design 698 Performance Surveillance Version

- LARGE ACQUISITION BASE POTENTIAL
- OV(X) BATTLEFIELD ACTIVE/PASSIVE WEAPONS CONTROL SYSTEM
 - ARMY (OV-1 REPLACEMENT)
 - USMC (OV-10 REPLACEMENT)
- SEARCH AND RESCUE
- FOREIGN NAVIES
- COMMERCIAL/EXECUTIVE TRANSPORT (STRONG NASA INTEREST)
- OIL RIG TRANSPORT

Figure 19 Other Applications of Subsonic Turbofan V/STOL

Ship Options

One of the first considerations in shipboard operations of a new class of airplane is the amount of landing area required for operations aboard ship.

Figure 20 compares Design 698 with the plan area of a Sikorsky LAMPS Mark-III helo. It can be

seen at once from this Figure that the required operating deck area is much smaller for the turbofan design, and additionally, it is probably much safer because of the absence of the possibility of the rotor tips striking hangar or deck structure. Furthermore, the high disk loading turbofan aircraft is inherently less gust-susceptible than a helicopter during hovering operations.

The next immediate question of interest is the size of the aircraft, not only for operations, but for

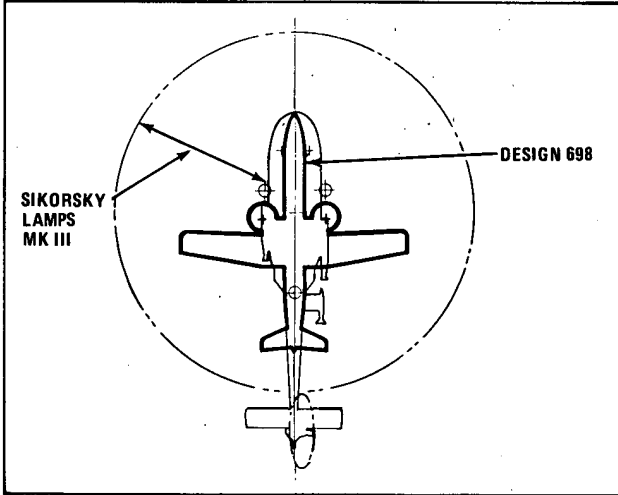

Figure 20 Landing Pad Compatibility

hangaring. Figure 21 shows the comparison of our Design 698 with several of the helicopters existent today, or planned for operations in the future. Design 698 is compared with the SH-3 Sea King, today's Kaman SH-2 LAMPS, and the newly designed and acquired Sikorsky LAMPS Mark-III helos. The size comparison is quite striking.

Hangar compatibility is of great importance, since modification of ships is often a painful and expensive proposition. Figure 22 shows the relative hangaring of the Design 698 on the Perry FFG-7 class Frigate. It can be seen that the airplane hangs very nicely.

Figure 23 shows the same sort of diagram, but for the Spruance class DD-963 Destroyer. Here again two aircraft can be hangared in this ship, which was originally designed to accommodate two LAMPs helos. One minor hitch here is that the outer airplane locks the inner airplane into the hangar due to the increased folded span of 698 vs. the helo.

Moving upward in air capability for ships, in Figure 24 we see the hangaring capability of Design 698 on a ship which was designed by NavSea, but was never constructed - the DDH. This was a Spruance-class destroyer modification involving a five-aircraft hangar, which would give the ship a basic round-the-clock surveillance capability without substantially degrading the basic ASW mission of the ship.

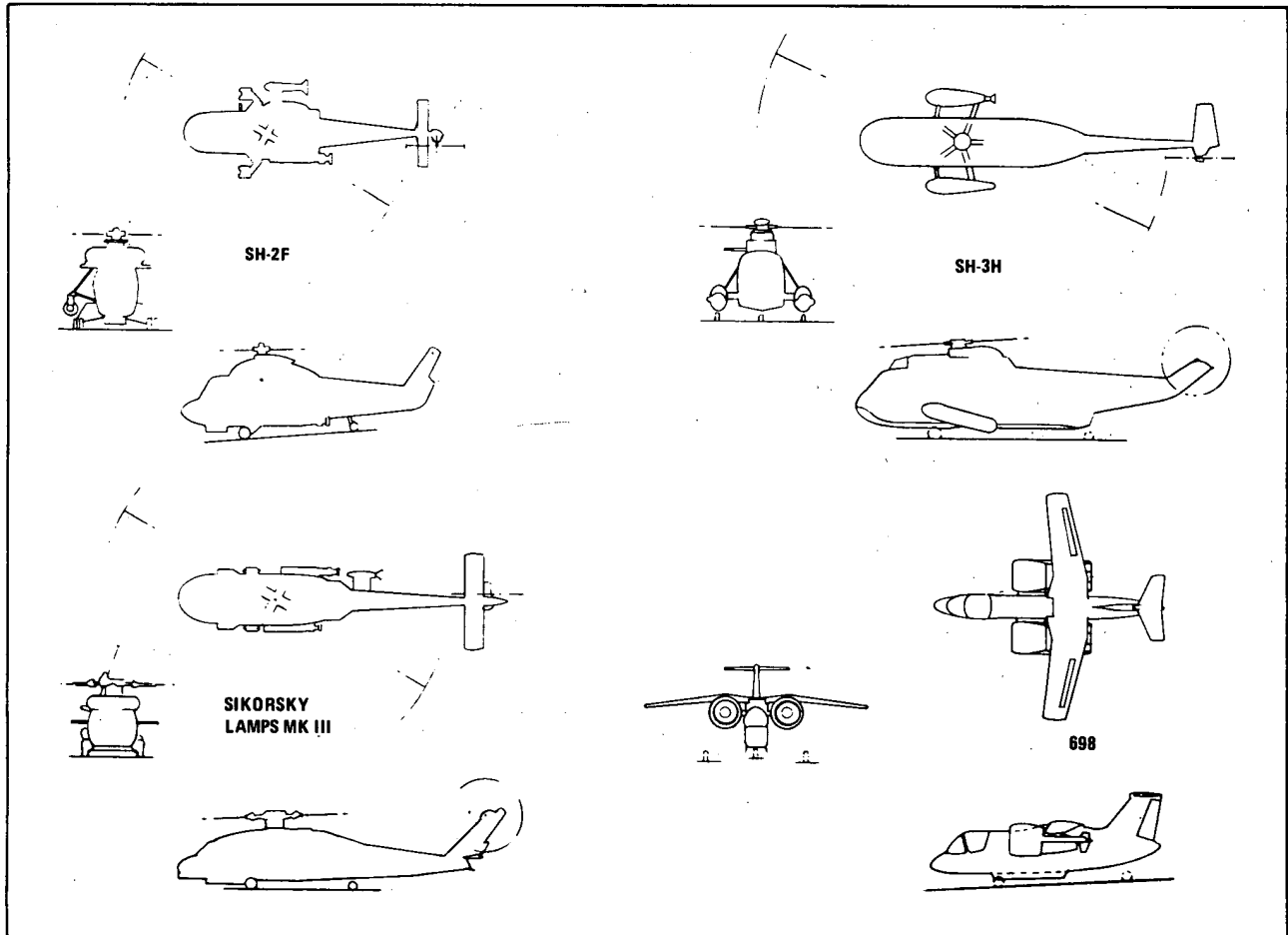

Figure 21 Helicopter Comparison

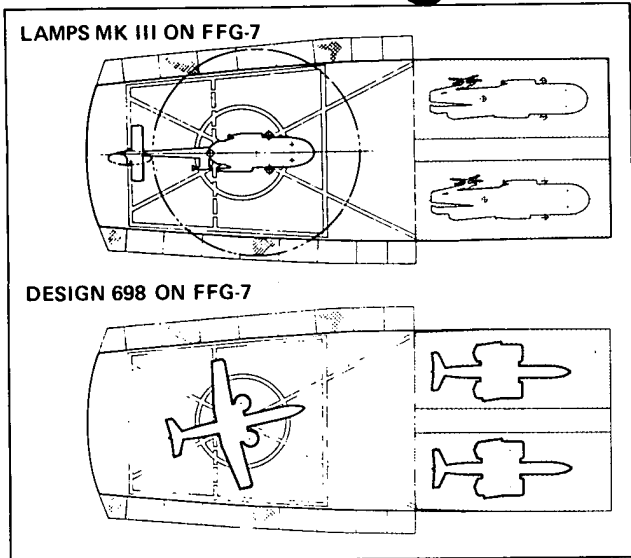

Figure 22 Comparison of Design 698 with LAMPS MK III Helo on FFG-7

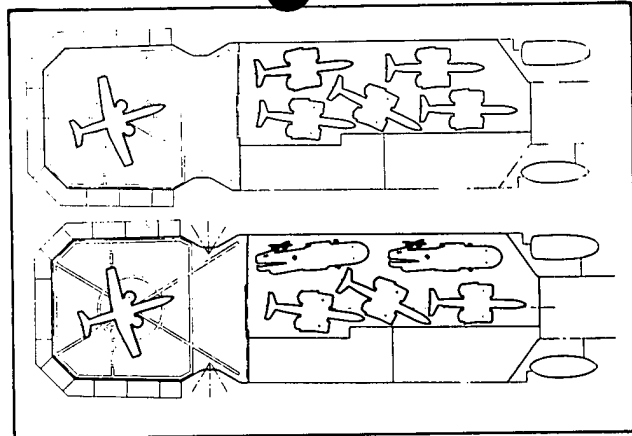

Figure 24 Design 698 on DDH

Turning now to Figure 25, we have depicted a ship which we have dubbed the DGV, Guided Missile Aviation Destroyer. This ship has been arrived at as a reasonable design by the joint efforts of Litton/Ingalls and Grumman. The ship would displace about 12,000 tons full load and is 569 ft. long. It is a high-speed surface combatant carrying 120 missiles in vertical launch tubes. The complement of aircraft for this ship would nominally be eight surveillance/missileers and two jammers, for a maximum of ten aircraft aboard.

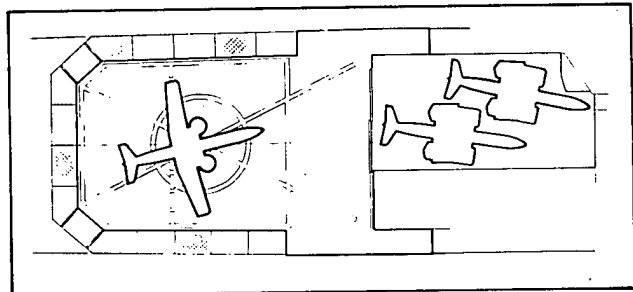

Figure 23 Design 698 on DD-963

Figure 26 illustrates the planning for sea-based aircraft among friendly nations projected to the year 1987. The total number of aircraft spots on these vessels is projected to be 584, while approximately 300 are existent today. We feel that a substantial number of these ship spots could be occupied by aircraft of this type.

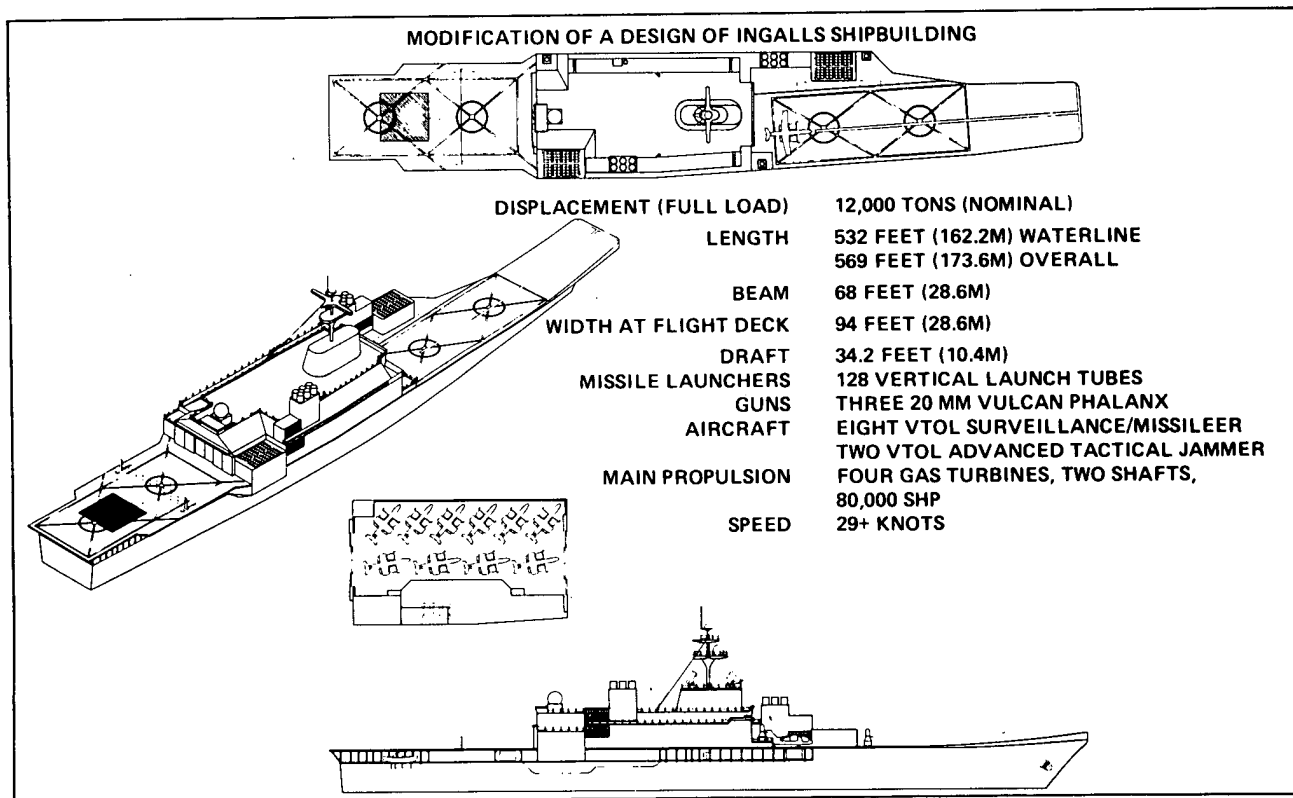

Figure 25 DGV Guided Missile Aviation Destroyer

COUNTRY	LIGHT CARRIERS (16-25 ACFT)	CRUISERS (2-9 ACFT)	FRIGATES/ DESTROYERS (1-3 ACFT)	TOTAL ACFT
ARGENTINA	1	2	8	36
AUSTRALIA	1		3	23
BRAZIL	1		7	27
CANADA			14	20
FRANCE	3	1	15	141
GERMANY			12	24
ITALY	1	3	18	61
JAPAN			9	17
NETHERLANDS			20	38
SPAN	1		3	25
UNITED KINGDOM	3	2	70	138
OTHER*		3	29	34
TOTAL ACFT	255	42	287	584

* TOTAL OF SEVEN SMALL COUNTRIES

Figure 26 1987 Projected Sea Based Aircraft - Friendly Nations

Design 698 Aircraft Development Program

Figure 27 summarizes the testing of our Design 698 in the 3 categories of wind tunnel, radio-control models, and simulation against a background showing one of our more interesting and dramatic tests of the configuration. This was a whirling arm transition facility where the aircraft could be taken from hovering flight through transition to wing-borne flight and back down again on the end of a 50 ft. ultra-lightweight whirling arm. It was found that transitioning of the aircraft with the crudest type of pitch, RPM, and engine nacelle tilt controls, aided only by a pitch-rate gyro, could be accomplished very easily as a manual task.

It is important to note that most of the tests performed on Design 698 (Navy and NASA contributions to the full-scale model are the most notable exception) were conducted under Grumman Independent Research and Development funding. The original impetus for this work was the Navy's Type A VSTOL program, which was terminated in the latter part of 1978. Fortunately, the technical work for this program was almost entirely applicable to Grumman's follow-on initiative, which was the idea of small aircraft for surface combatants, which for Grumman was nothing but a return to our earlier Nutcracker concept. Started some five years earlier, the Nutcracker had the same intent, but with a much less desirable aircraft and shipboard equipment configuration. At any rate, the Type A program gave us a large data base to work with, and fortunately the basic aircraft configuration has remained stable for a number of years so that we could really concentrate our research on the fundamentals of the configuration.

The end objective, of course, of the testing illustrated in Figure 27 is to provide the basis for construction of a manned flight demonstrator. Further illustration of the technology demonstrator approach for the turbofan class of aircraft is shown in Figure 28. Many VTOL concepts have been previously demonstrated, and yet this turbofan concept, potentially one of the most useful, has not been demonstrated. This comment will be further explained in the next figure. As an aside, many of the demonstrations of VTOL concepts occurred in the 1950's before technology was ready to give us production aircraft with a high level of mission capability, that

is, engine thrust-to-weight ratios had not advanced sufficiently, nor had composite structures and ultra lightweight avionic systems with a high level of capability. Today, of course, the availability of these technologies changes the picture entirely. What happened in the '50's was that the Korean War showed how useful helicopters could be. At the same time, their drawbacks in terms of speed, range and comfort were immediately obvious. It was quite natural to seek a marriage of the virtues of conventional aircraft with vertical lift and the search started with great vigor and little success, simply because technology was not ready to provide the marriage of the best facets of both worlds.

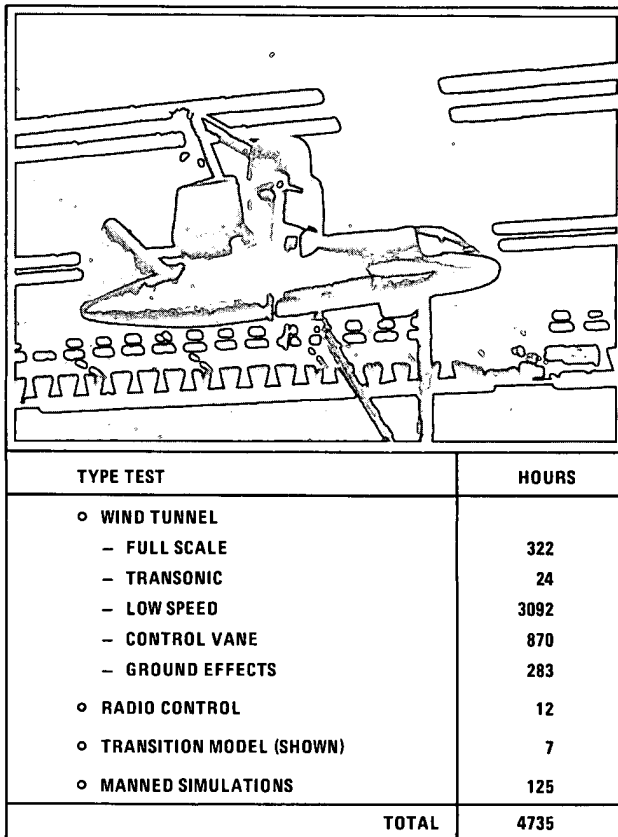

Figure 27 Design 698 Testing

- MANY VTOL CONCEPTS DEMONSTRATED PREVIOUSLY - YET THIS, POTENTIALLY ONE OF THE MOST USEFUL, HAS NOT BEEN
- GRUMMAN, IN COOPERATION WITH USN AND NASA, HAS A FULL PROGRAM OF WIND TUNNEL TESTS UNDERWAY ON PATENTED DESIGN 698 AIRCRAFT; CONFIGURATION PASSED NAVAIR MINI-EVALUATION
 - SMALL SCALE TESTS
 - FULL SCALE TESTS IN NASA 40 FT. X 80 FT. TUNNEL JUNE 1980
- FOLLOWING TUNNEL TESTING, GRUMMAN WILL BE READY TO BUILD A TECHNOLOGY DEMONSTRATOR AIRCRAFT
 - LOW COST PROGRAM THROUGH USE OF [EXISTING TF 34 ENGINES:] 2 AIRCRAFT

Figure 28 Subsonic Turbofan Aircraft Demonstrator Program

We at Grumman are convinced that the time is right for a technology demonstrator in this class which could ultimately lead to a very useful production aircraft with both the capability to carry fuel for a very substantial mission capability, plus a very good mission load while operating in the vertical takeoff mode. Towards the end objective of demonstrating this technology, Grumman, in cooperation with NASA and the U.S. Navy, has recently

completed a full-scale wind tunnel test of a demonstrator configuration based upon the use of Mitsubishi-2 airframes. This full-scale tunnel test will be followed by outdoor tests of the aircraft in ground proximity to determine its characteristics in terms of stability, control, suckdown, and reingestion. The full scale tests are accompanied by a full program of small scale tests of an aircraft having exactly the same configuration as the full scale tunnel model. Following the completion of this broad test program, Grumman will be in a position to propose to build a technology demonstrator of this airframe. We can offer a low-cost program through the use of existing TF34 engines, which is most attractive in these austere R&D times.

Figure 29 illustrates my earlier comment on the fact that a turbofan aircraft of this class has never before been demonstrated. Figure 29 is the classical plot of thrust achieved per horsepower invested as a function of the disk loading of the propulsive device. There are two ideal curves shown, the ideal fan and the ideal prop. Against this backdrop are spotted some, but not all, of the demonstrator concepts which have been tried in the past. It can be immediately seen from this chart that the low disk loading area has been thoroughly covered, and some very significant work has been done in the higher disk loading area, but the cloud in the center, which contains all of the engines in the high-bypass commercial or military category, has never been exposed to a VTOL technology demonstrator investigation. In other words, there is a very broad demonstrator gap just where the most efficient cruise engines from a commercial and military point of view lie. These also have excellent static thrust characteristics. It is our proposition to fill this gap with a Design 698 technology demonstrator.

Figures 30, 31 and 32 show three pictures of the Design 698 full-scale wind tunnel model mounted on the outdoor test stand, where initial engine runs were conducted, and within the tunnel set up for transition testing. The data resulting from this test program are in the analysis and reporting cycle for dissemination to the industry at large. Seven-hundred and forty independent measurements are available spanning the range of forces, moments, pressures, temperatures, acoustics, vibration, and so forth.

In addition to measurement of overall aircraft forces and moments, there is a separate balance system for measuring the forces on the engine dumbbell assembly alone. A further set of balances is in the vane assemblies for measuring the vane lift, drag, and hinge moment.

The approach to building a flight technology demonstrator of the Design 698 aircraft is illustrated in Figure 33. The nose module of a Mitsubishi-2 transport would be modified for a pair of side-by-side ejection seats. A new center module would be added for balance. The dumbbell assembly would be an entirely new fabrication, specifically for the demonstrator aircraft. The Mitsubishi-2 aft section and wing assemblies could be used with minor modification. A new vertical and horizontal tail assembly would have to be provided, as would a retractable forward main gear set and a retractable tailwheel assembly. The question frequently arises in technology demonstrators, "Why not use a fixed landing gear?" It was felt in the case of this aircraft, for which high speed performance is really its strongest suit, it would be foolish to build an aircraft which would be limited by a fixed landing gear.

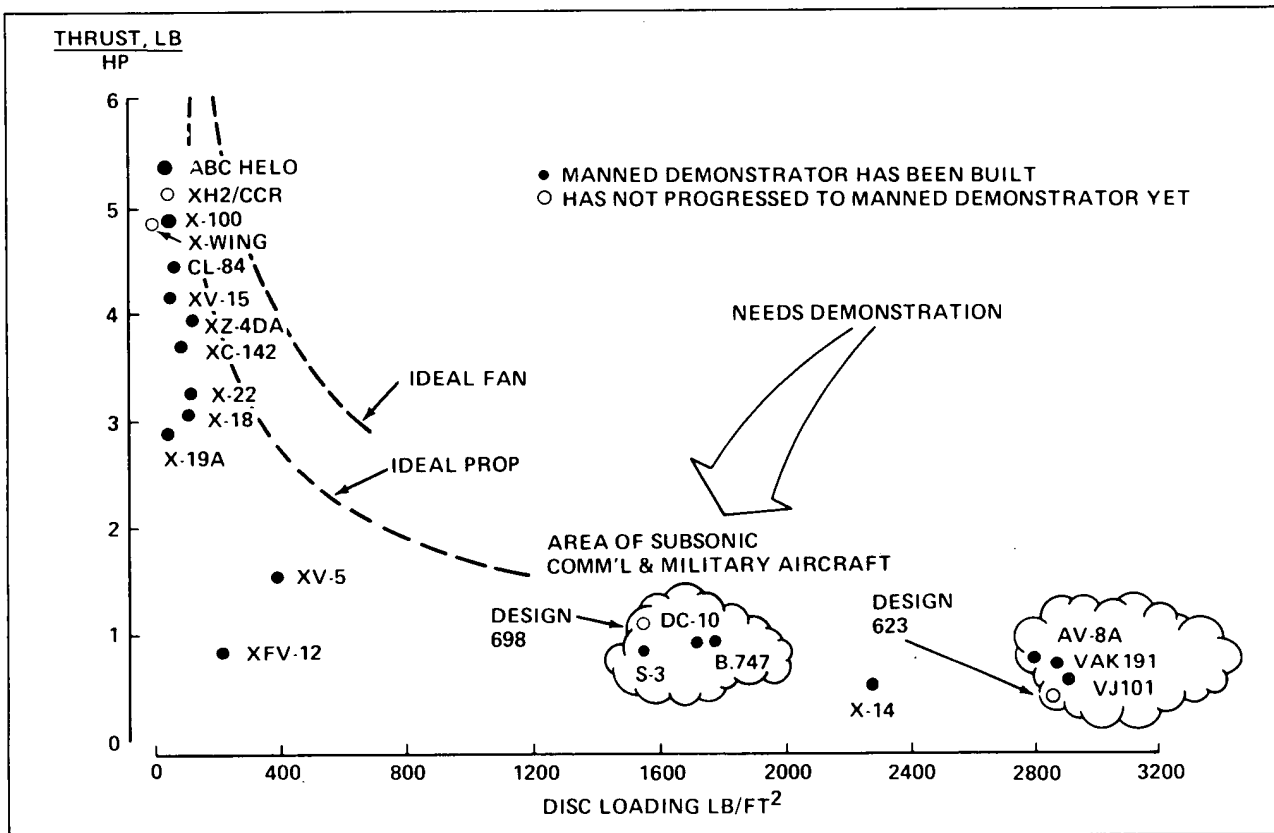

Figure 29 VTOL Technology Demonstrators

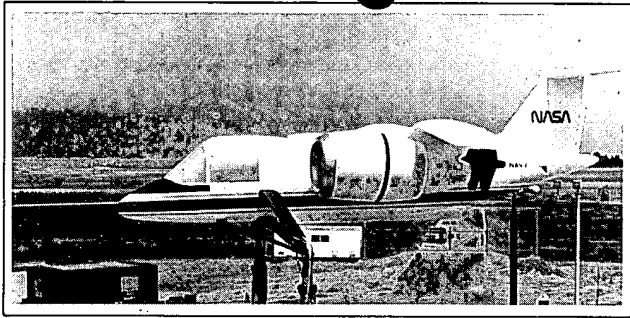

Figure 30 Full Scale Model on Outdoor Test Stand - Nacelles in Cruise Position

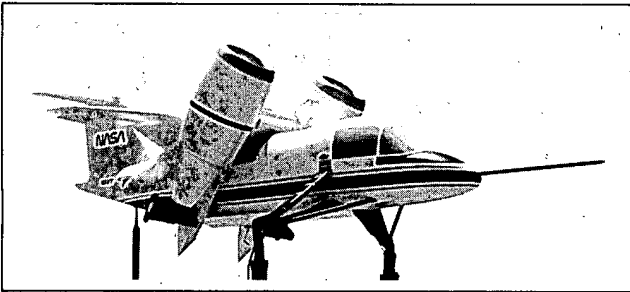

Figure 31 Full Scale Model on Outdoor Test Stand - Nacelles Rotated

In summary, Grumman believes strongly, not only in our basic aircraft design concept, but in the value of a flying technology demonstrator program predicated upon what we feel are solid future naval and military applications, as well as civil uses of this 20,000 lb. class of VTOL.

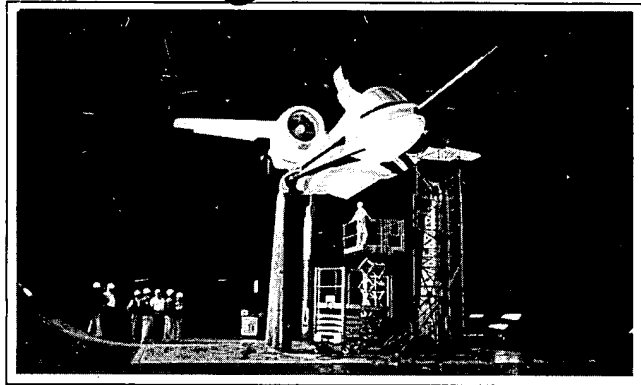

Figure 32 Full Scale Model in NASA Ames 40 Ft x 80 Ft Wind Tunnel

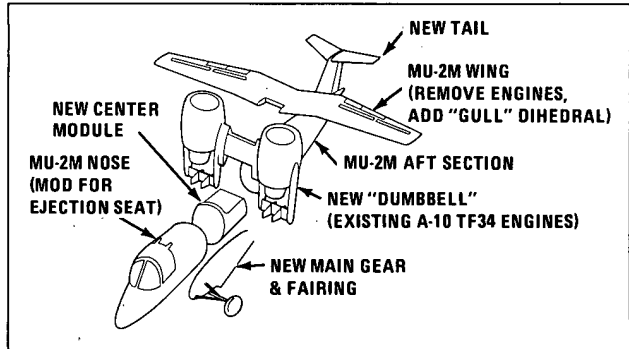

Figure 33 Demonstrator Fabrication Approach