

8452-65-43

TM-65- 5

SPECIAL HANDLING

COPY NO. 1

TACTICAL MULTISENSOR RECONNAISSANCE

VOL. 5

SYSTEM CONCEPT

15 JUNE, 1965

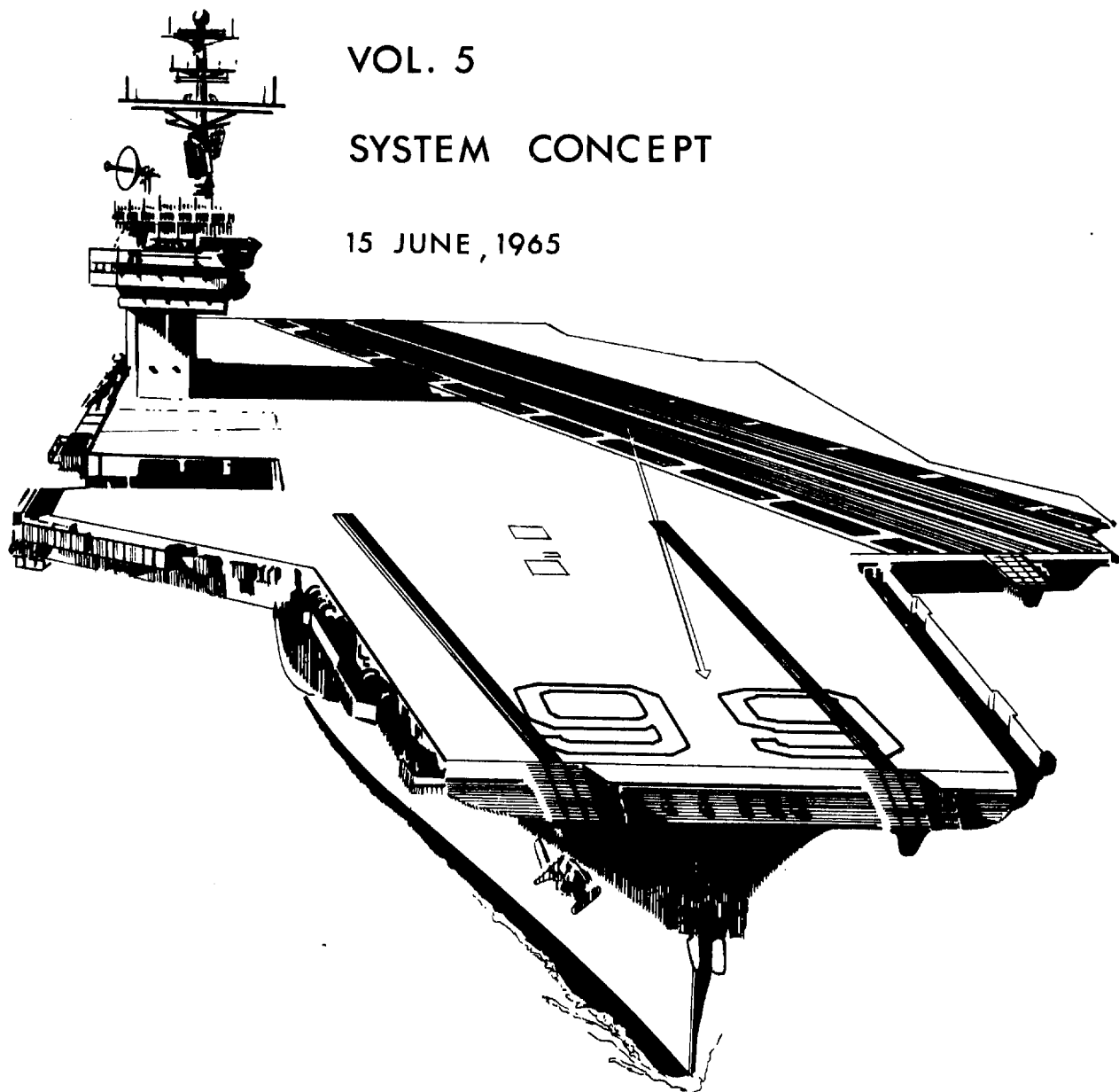

25 YEAR RE-REVIEW

SPECIAL HANDLING

SPECIAL HANDLING

CONTENTS

Introduction	xi
1. Synopsis	1-1
2. Engineering Summary.	2-1
2.1 Mission Analysis and Performance Requirements.	2-2
2.2 Sensor Integration	2-13
2.3 Optimized Multisensor System Utilizing Keying.	2-18
2.4 Typical Sensors and their Parameters	2-24
2.5 Observer	2-24
2.6 Photography.	2-25
2.7 Infrared	2-28
2.8 High Resolution Side Looking Radar	2-29
2.9 ELINT	2-30
2.10 Key System	2-31
2.11 Display System	2-32
2.12 Data Management.	2-33
2.13 Data Preparation	2-33
2.14 Priority Analysis.	2-34
2.15 Mission Analysis	2-35
2.16 Viewing System	2-36
2.17 Data Storage and Retrieval	2-37
2.18 Mission Materials.	2-37
3. Mission Parameters	3-1
4. Optimized Multisensor System	4-1
4.1 Target Data Gathering Requirements	4-1
4.2 Sensor Operating Characteristics	4-16

SPECIAL HANDLING

SPECIAL HANDLING

CONTENTS (Continued)

4.3	Sensor Operating Procedures.	4-106
4.4	Observer Display and Control Operations.	4-117
4.5	Airborne Data Processing	4-134
4.6	Data Links	4-142
4.7	Data Management.	4-183

SPECIAL HANDLING

FIGURES

2-1.	Time Response Cycle.	2-4
2-2.	Target Class Distribution in Parameter Space	2-9
2-3.	Imaging Sensors.	2-12
2-4.	Sensor Capabilities.	2-14
2-5.	Airborne System Concept.	2-19
4-1.	Solar Horizontal Plane Illuminance as a Function of Solar Altitude in Average Clear Weather.	4-3
4-2.	Constant Solar Horizontal Plane Illuminance as a Function of North Latitude and Time of Year (time: local apparent noon) . .	4-4
4-3.	Constant Solar Horizontal Plane Illuminance as a Function of North Latitude and Time of Year (time: local apparent noon <u>±2</u> hours).	4-5
4-4.	Constant Solar Horizontal Plane Illuminance as a Function of North Latitude and Time of Year (time: local apparent noon <u>±5</u> hours).	4-6
4-5.	Reflected Radiation Useful for Near Visual UV and IR Photography as Restricted by Atmospheric Absorbption.	4-7
4-5(a).	Plot of Soviet Radar over 2500 to 6000 Megacycle Frequency Range	4-12
4-6.	Typical Survivability vs Operating Altitudes for High Performance Aircraft Tactical Reconnaissance	4-17
4-7.	Frame/Strip Camera - 44 mm EFL, 5" Sq. Format (vertical) (1 permanent) (2 optional)	4-21
4-8.	Frame Camera - 3-6" EFL, 5" Sq. Format (side oblique).	4-23
4-9.	Panoramic Camera - 3" EFL, 70 mm or 5" Format (vertical)	4-25
4-10.	Frame or Panoramic - Constant Scale Pan 2" - 4" EFL, 70 mm Format (forward oblique)	4-27
4-11.	Urban Area - Black and White Print	4-29
4-12.	Urban Area - SO-121 Color Film	4-30

SPECIAL HANDLING

SPECIAL HANDLING

FIGURES (Continued)

4-13.	Urban Area - Additive Color from Black and White Negatives . . .	4-31
4-14.	Urban Area - Additive Color Camouflage Detection from Black and White Negatives.	4-33
4-15.	Forest Area - Black and White Print.	4-34
4-16.	Forest Area - SO-121 Color Film.	4-35
4-17.	Forest Area - Camouflage Detection Film.	4-35a
4-18.	Constant Scale Pan - 6-12" EFL, 70 mm Format Vertical (high-med altitude).	4-36
4-19.	Panoramic - 24" EFL, 5" Format, Vertical (high alt.)	4-38
4-19(a)	Example Mounting for IR Panoramic Sensor	4-41
4-20.	Infrared Scanner Optical Configuration	4-44
4-21.	Signal Channel Block Diagram	4-46
4-22.	Airborne Signal Processing Block Diagram	4-50
4-22(a)	Idealized Video Waveform (end of mirror scan).	4-51
4-23.	Carrier Based Data Processing	4-55
4-24.	Interconnection Between Requirements and System Parameters for a Synthetic Array Radar	4-59
4-25.	Parameter Derivation Flow Chart Synthetic Array Radar Imagery. .	4-61
4-26.	Possible Radar Sensor Subsystems	4-64
4-27.	Radar Unit Block Diagram	4-65
4-28.	Dual Channel Airborne Recorder	4-66
4-29.	Range Coverage	4-74
4-30.	Segmented Recording.	4-76
4-31.	Total Range Swath per 100 Pounds of Recorder	4-78
4-32.	Real Time Storage Tube MTI Processor	4-79
4-33.	Real Time Storage Belt Processor	4-83
4-34.	System Weight for Different Configurations	4-84
4-35.	ELINT Subsystem Block Diagram	4-91
4-36.	Basic Receiver Electronics	4-93
4-37.	Range Accuracy as a Function of Time and Azimuth	4-96
4-38.	Forward-Looking Monopulse Antenna (multi-mode spiral).	4-98
4-39.	Projected $\phi - \theta$ Grid	4-99

SPECIAL HANDLING

FIGURES (Continued)

4-40.	Coverage Diagram of DF Systems	4-101
4-41.	Multisensor Components Fields of View	4-107
4-42.	ELINT Situation Display.	4-125
4-43.	Sensor Coverage Areas (500 feet altitude).	4-128
4-44.	Airborne System Concept	4-139
4-45.	Data Processing Flow Diagram	4-141
4-45(a)	Conceptual Data Link	4-144
4-46.	Imagery Sensor Resolution.	4-148
4-47.	Commercial TV Frequency Spectra.	4-155
4-48.	Estimated Spectra of the HRSLR Sensor.	4-156
4-49.	Estimated S/N in a KC Band South Vietnam - March, 1965	4-161
4-50.	Multiplexing - Modulation Technique (straight-forward analogue).	4-171
4-51.	Multiplexing - Modulation Technique (multiple RF carriers)	4-171
4-52.	Multiplexing - Modulation Technique (straight-forward digital)	4-172
4-53.	Multiplexing - Modulation Technique (hybrid analogue-digital).	4-172
4-54.	Multiplexing - Modulation Technique (multiple digital transmitters).	4-173
4-55.	Detailed Breakdown of Signal Flow in the Reconnaissance Center	4-187

SPECIAL HANDLING

SPECIAL HANDLING

SPECIAL HANDLING

TABLES

2-1.	Targets and Data	2-5
2-2.	Information Requirements with Respect to Targets.	2-7
2-3.	Report Time and Resolution for Various Target Types	2-8
4-1.	ELINT Input Data Requirements	4-15
4-2.	Example Scanner Parameters.	4-43
4-3.	Weight Estimates - Airborne Data Processing Equipment	4-49
4-4.	Comparison of Radar Characteristics	4-69
4-5.	Weight Estimates for "A" Design	4-72
4-6.	Weights for Storage Tube Processor	4-81
4-7.	Weights for Storage Belt Processor	4-81
4-8.	Receiver Characteristics.	4-94
4-9.	Typical Miniature Aerospace General Purpose Computers (December 1964)	4-103
4-10.	Miniature Airborne Computer - Typical Characteristics	4-105
4-11.	System Resolution versus Data Link Resolution	4-153
4-12.	Summary: Wide Band Link Parameters	4-157
4-13.	Digital Data Format	4-159
4-14.	Wideband Link Characteristics Summary	4-163
4-15.	Signal Power at Receiver, P_R , for Three Frequency Bands	4-166
4-16.	Receiver Noise Temperatures for Three Frequency Bands	4-167
4-17.	Resulting Receiver S/N Ratios Three Frequency Bands	4-168
4-18.	Transmitted Power Required - Modulation System B-1.	4-177
4-19.	Transmitted Power Required - Modulation System B-2.	4-177
4-20.	Transmitted Power Required - Modulation System B-3.	4-179
4-21.	Transmitted Power Required - Modulation System B-3 (PCM/M ¹ FSK).	4-179
4-22.	Typical Operational Characteristics of Disc Storage Systems	4-205

SPECIAL HANDLING

SPECIAL HANDLING

SPECIAL HANDLING

SPECIAL HANDLING

INTRODUCTION

The multisensor system which is conceptually delineated here is based on the cooperative effort of the technical specialists from each sensor area.

Sensors treated were photography - by Itek Corporation; infrared (IR) - by Baird Atomic; high resolution side looking radar (HRSLR) - by Conductron, Inc.; and electronic intelligence (ELINT) - by Airborne Instruments Laboratory, with Itek Corporation managing the overall multisensor system effort.

In considering the optimization of the system for minimum interpretation time, the following two factors were paramount in the study.

1. Simplicity — For an operational, combat system, it is recognized that only the essential tools will be fully utilized by men under extreme pressure.
2. Man/Machine Relations — In a fast moving and changing environment, man's limited ability to deal with vast amounts of simultaneous data is recognized, and the system has been conceived to utilize to the fullest the data handling capability at the man/machine interface by using automatic systems to preselect information and bring to the man a volume of data which can be handled quickly to produce effective timely decisions.

The optimized multisensor system which is presented has been purposely divorced from existing systems and vehicles, and is based on parallel studies of the basic elements on which system requirements are founded. The sensor technology is current capability suitable for prototype hardware by 1967, and does not represent nebulous advances in the state-of-the-art. Some of the systems concepts are new, but they utilize available components, ingeniously combined to enhance the utilization of the multisensor system.

SPECIAL HANDLING

SPECIAL HANDLING

The multisensor system has resulted in the compilation of six documents, which are as follows:

- Volume 1 - Naval Doctrine
- Volume 2 - Target Characteristics
- Volume 3 - System Characteristics
- Volume 4 - Technology Survey
- Volume 5 - System Concept
- Volume 6 - Summary

The next section is a summary of the information presented in Volume 5 - System Concept.

SPECIAL HANDLING

1. SYNOPSIS

The multisensor system conceived in this study combines a small number of unusual state-of-the-art sensors to arrive at the airborne equipment complement, and adds a wideband data link for real-time relay of selected information.

Photographic Data is considered as the prime record, since it produces high resolution imagery having the highest information content.

The aircraft systems will produce prime records, and transmit secondary records. Thus, redundant records will be generated to cover two possibilities: first, the need for image information prior to the return of the aircraft; second, to provide image information should the aircraft be lost or the records damaged in combat.

The system will provide adaptive analysis by keying all records with a locator to indicate the detection of an active or potential target as automatically determined from the SLR, ELINT and IR sensors or the observer.

A real-time electro-optical operator display is provided which presents keyed, geographically located, probable targets and moving targets on an up-to-date Order of Battle representation.

The operator display will be designed to utilize the 4 to 5 bit per second visual data rate of man, but it will also have a IR image mode for navigation, and night reconnaissance.

A simultaneous wideband and narrowband data link are suggested to relay information to the analysis center. For real-time analysis, the same display as is in the aircraft is considered proper, so that areas of high interest can be set up for detailed analysis of the prime records. The wideband link, perhaps requiring a relay system, could provide real-time IR imaging, SLR imagery and ELINT locators for those target systems with very short timeliness requirements.

SPECIAL HANDLING

1-1

SPECIAL HANDLING

The records, prime or secondary, will be analyzed using the keys to correlate the areas of high target probability. A viewer which has available on call all the image records, and displays only two major and two historical records is recommended to best utilize the interpreters' viewing capability.

The record handling system is designed to use machine aids wherever possible, but is configured for manual operation in an emergency.

SPECIAL HANDLING

2. ENGINEERING SUMMARY

The derivation of a system usually a complex compromise, based on the operational and design tradeoffs which have to be made. The simplest and most reliable designs will result when there is a thorough understanding of the purpose for which the system is ultimately to be used. Unless there is a deep appreciation of the user's problems, and the system technology, it is difficult for the design to evolve into a useful system.

In designing a tactical multisensor reconnaissance system, such as is presented in this study, an attempt was made to gain such an understanding and to apply the knowledge obtained to the derivation of the system. This has led to a philosophy of design which stresses the use of automatic equipment to accomplish functions which are beyond the data rate capabilities of man, but which take full advantage of man's subjective capabilities to recognize patterns, evaluate situations, make decisions, and to take responsive action.

The system, however, retains the use of manual modes to backup automatic equipment, of course, accepting the performance reduction thus caused. The concept provides for simple designs, and for the incorporation of redundant records and flow paths throughout the system. The flexibility thus introduced also provides for a priority intelligence path to speed up the processing of vital real time data.

During the study, only the design concept has been prepared, using hardware examples to provide explanations for some of the system arrangements.

Before examining the capabilities of the sensors and data processing systems, it is necessary to evaluate the needs and priorities of the intelligence cycle of tactical multisensor reconnaissance.

SPECIAL HANDLING

2-1

SPECIAL HANDLING

2.1 MISSION ANALYSIS AND PERFORMANCE REQUIREMENTS

An optimized tactical multisensor reconnaissance system is conceived by first developing a set of performance requirements. These, in turn, are derived from the operational requirements arising out of the basic reconnaissance mission(s). This discussion will therefore begin with an analysis of the intelligence objectives pertinent to the full range of tactical situations, then proceed to a specification of the physical data that must be reported to the air intelligence officer, and conclude with technical performance requirements on the sensors and means of communication. A comparison is made between these requirements and the performance obtainable by conservative extrapolation of current state of the art to a time not later than mid-1967. This comparison yields an optimum choice of the sensors to perform each of the defined reconnaissance functions, and leads to a requirement for mutual reinforcement of the data output, especially between image and non-image classes of data. Sensors considered for this task are visual (observer), photographic (cameras) infrared (IR), high resolution side looking radar (HRSLR), and electronic intelligence.

The tactical environments of greatest significance in which air reconnaissance will be performed are represented by operations against hostile land forces. These will be assisted in some cases by small surface craft and submarines. Typical examples are an amphibious operation and a continued series of carrier-based interdiction strikes. Intelligence is required in support of two distinct functions: strike direction and prevention of tactical surprise. For the purpose of identifying reconnaissance targets, strikes can be classified in three classic missions: winning and holding air superiority, interdiction, and close support of friendly ground forces. Tactical surprise prevention is concerned with threats to both the fleet and friendly ground forces.

For strike direction, reconnaissance is performed to determine:

1. Identity and location of strike targets.
2. Hostile air defense capability (location and strength of air defense units).
3. Effectiveness of previous strikes (damage assessment).

SPECIAL HANDLING

For tactical surprise prevention, reconnaissance is performed:

1. To detect the existence of threat forces.
2. To evaluate the nature, degree and imminence of the threats.

Consider now the reconnaissance targets that are associated with each of the missions, and specific types of information that is to be collected from each. Table 2-1 shows the classes of targets by missions. Table 2-2 shows the information required with respect to each target in support of the mission. These tables are not exhaustive, but include most of the targets of major importance. An examination of Table 2-3 shows that, with few exceptions, the sensory data required is imagery that can be interpreted by visual inspection. Non-image data, consisting of ELINT, moving target indication (MTI) and radiometric highlights ("hot spots") are in almost all cases inadequate to provide the clues necessary for target identification when used without imagery. The principal exception lies in the class of radars associated with air defense units, where ELINT by itself can provide high confidence identification, subject to the condition of active radiation by the radars. However, location accuracy achieved by this means alone is less than that desirable for strike direction, though it can be used.

Therefore, the first conclusion is that the system must be capable of collecting and presenting imagery data of quality sufficiently high to permit identification and assessment of condition of the targets. While "quality" is a complex concept, for the purpose of defining order of magnitude performance requirements, and choosing between sensors, it is suitable to measure it by the single parameter resolution. Table 2-3 lists the range of resolution for each class of target. (Ref. Vol. II, Target Characteristics).

The other parameter of the collection-reporting process that must be specified is timeliness. This quality may be measured by a parameter defined in the context of the complete response cycle, beginning with the instant of collection of the sensory data and ending with completed action (e.g., weapon delivery, evasion accomplished, redeployment completed), which is illustrated in simple form in Fig. 2-1. Since the end product of the multisensor system is delivered to the air intelligence officer, the appropriate parameter is the

SPECIAL HANDLING

2-3

SPECIAL HANDLING

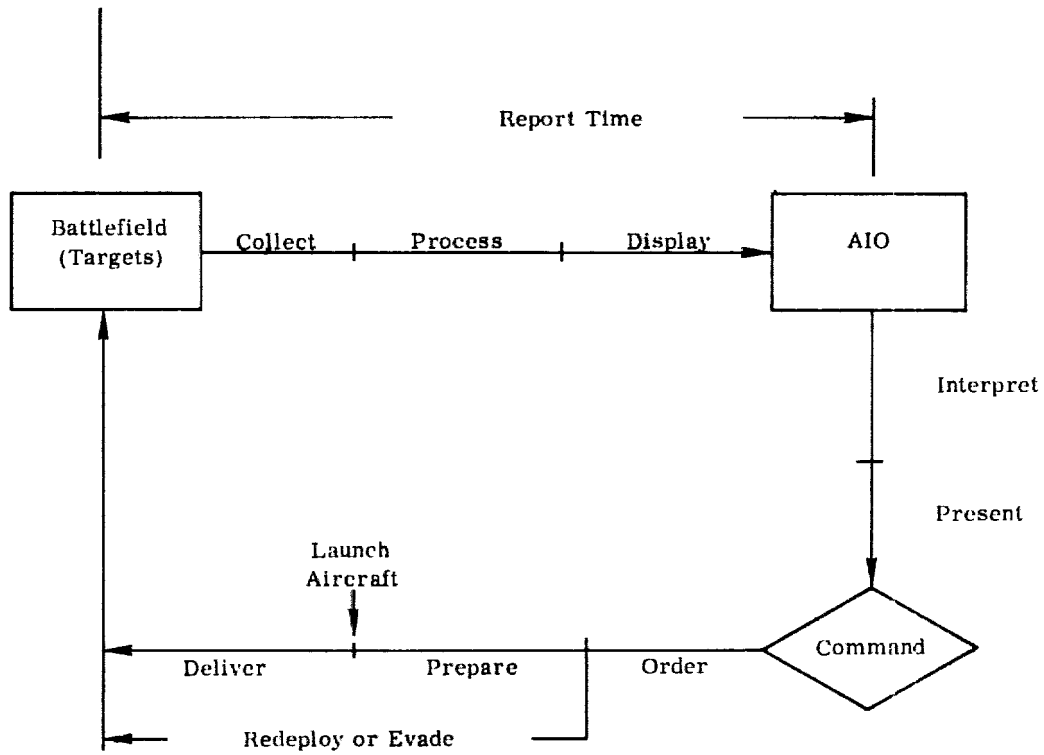

Fig. 2-1 — Time response cycle

SPECIAL HANDLING

SPECIAL HANDLING

Table 2-1. Targets and Data

Strike Direction: Air Superiority

Air Interception:	Airfields, parked aircraft, GCI and TARC complexes
Missiles:	SAM complexes, launchers, missile storage, radars
AAA:	Batteries, guns, radars

Strike Direction: Interdiction

All Air Superiority Targets (for evasion)	
Transportation Bottlenecks:	Bridges, railroad junctions, tunnels, marshalling yards, docks
Tactical Supply Concentrations:	Fuel stores, vehicle parks, ammunition stores
Communication Nodes:	Transmitters, telephone centers
Power Facilities:	Central stations, substations, transmission lines
Industrial Facilities:	Factories, warehouses

Strike Direction: Close Support

Artillery
Armor
Troops
Fortifications and entrenchments

SPECIAL HANDLING

SPECIAL HANDLING

Table 2-1. (Cont.)

Tactical Surprise Prevention: Threat to Fleet

Attack and Bombing Aircraft (primarily parked)

SSM

Torpedo or Missile Boats

Submarines - principal responsibility is in other hands

Tactical Surprise Prevention: Threat to Ground Forces

Artillery SSM troops, armor, machine gun emplacements

SPECIAL HANDLING

Table 2-2. Information Requirement with Respect to Targets

Airfield:	Location, capability, condition structures
Parked Aircraft:	Location, type, condition, number
GCI Complex:	Location, type, radar components
SAM Complex:	Location, type, condition (readiness)
AAA:	Location, type of guns, radar, size, condition
Transport Bottleneck:	Location, identity, size, orientation, surroundings, distinguishing features, condition Same as for Transport Bottleneck
Communication Nodes:	Same as for Transport Bottleneck
Power Facilities:	Same as for Transport Bottleneck
Industrial Facilities:	Same as for Transport Bottleneck
Artillery:	Type, location, number of guns, revetments, auxiliary components, surroundings, motion
Armor:	Type, location, number, condition, motion
Troops:	Number, vehicles, motion, equipment
Fortifications, Trenches:	Location, description, size, ordnance
SSM:	Same as Artillery
Boats:	Location, type, number, armament, motion

SPECIAL HANDLING

SPECIAL HANDLING

Table 2-3. Report Time and Resolution
for Various Target Types

<u>Target Type</u>	<u>Resolution Range (feet)</u>	<u>Report Time Range (hours)</u>
1. Airfield	25 - 100	5 - 10
2. Parked Aircraft	2 - 30	0.5 - 2
3. GCI Complex	6 - 20	5 - 10
4. SAM Complex	5 - 50	3 - 5
5. AAA	3 - 25	0.5 - 2
6. Transport Bottlenecks	15 - 100	5 - 10
Tactical supply concentrations	10 - 100	5 - 10
Communication nodes	5 - 50	5 - 10
Power facilities	50 - 100	5 - 10
Industrial facilities	50 - 100	5 - 10
7. Artillery, SSM	4 - 8	0 - 0.5
8. Armor	2 - 8	0 - 0.5
9. Troops	1 - 4	0 - 1
Fortifications (passive defense)	2 - 4	0.5 - 5
Warcraft (small)	2 - 25	0 - 1

SPECIAL HANDLING

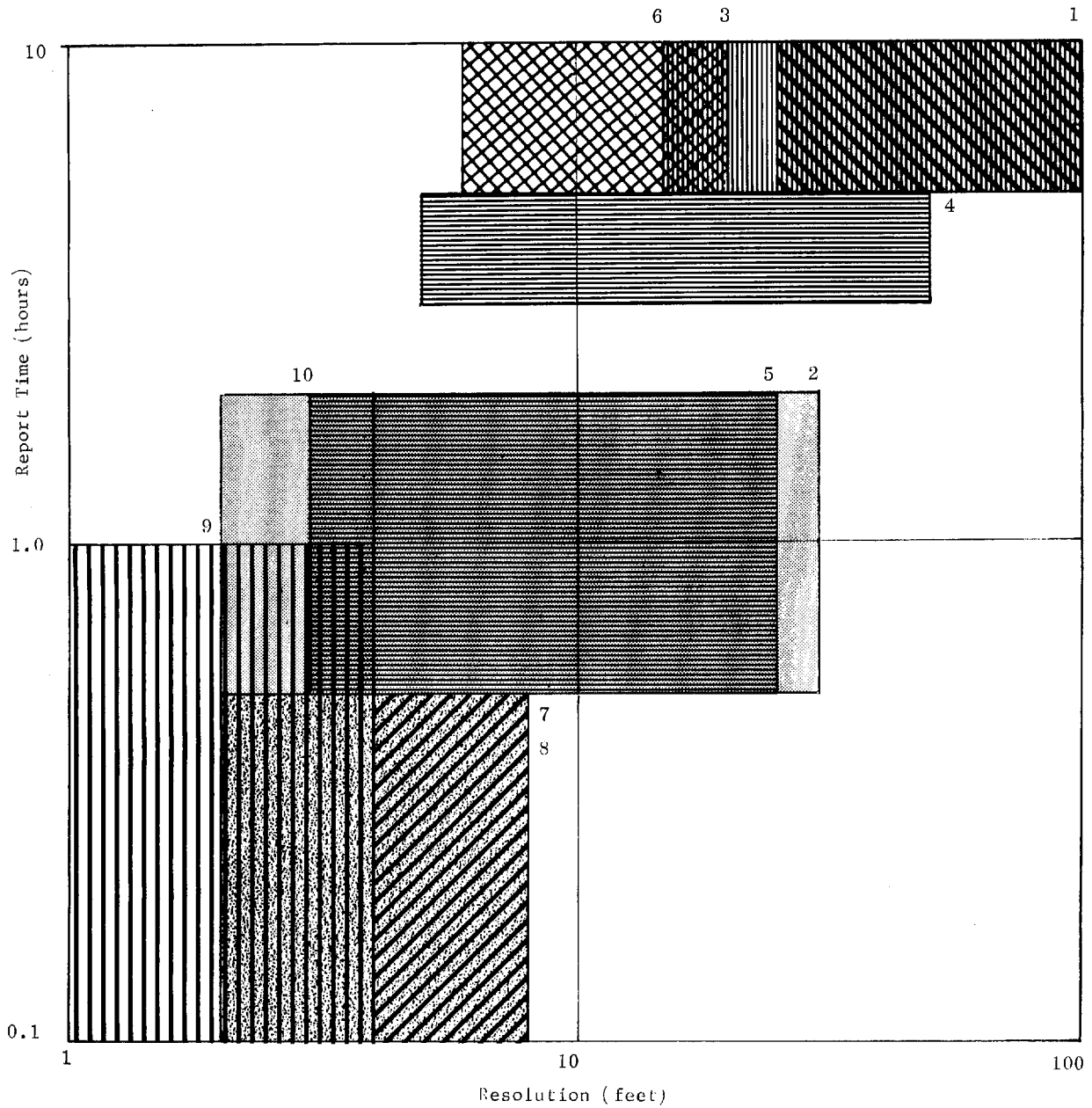

Fig. 2-2 — Target class distribution in parameter space

SPECIAL HANDLING

SPECIAL HANDLING

"report time", defined as beginning at the instant of collection and ending at the instant of delivery to the air intelligence officer, either as hard copy or visual display. Table 2-3 lists the range of allowable maximum report times for the targets. These are derived from the two basic functions (strike direction and tactical surprise prevention). For strike direction, the important considerations are the perishability of the data as determined by mobility and changeability of the target, and the time required to interpret the data, make a decision, order, prepare and deliver the strike. For surprise prevention, the important considerations are the time required for a threat to materialize and the time required to interpret the data, make a decision, and take counteraction.

Figure 2-2 shows how the target classes are distributed in the parameter space defined by report time and resolution. While the target list is not exhaustive and the report time and resolution requirements depend to some extent on judgment, the plot of Fig. 2-2 nevertheless reveals certain major features of the requirements. There is a rough correlation between the resolution element size and the report time. Furthermore, taking the mean time from data collection to return to carrier to be between one and two hours. There is a substantial set of targets requiring imagery reporting inflight. Some of these (e.g., artillery, armor, troops, and warcraft), generate a requirement for imagery to be reported almost in real time (maximum delay of a few minutes only). This set of targets is for the most part associated with ground combat and hence with the close support strike mission and prevention of tactical surprise to ground forces. Required resolution is 8 feet or less, and extends down to 1 foot. This target set is called Class A.

A second set of targets — Class B — consisting of parked aircraft and anti-aircraft artillery has slightly less exacting imagery requirements in both resolution and report time. Some effective intelligence is gained by reporting after landing, but much is lost unless reporting inflight is done.

Finally, the class of fixed or slow moving structures (Class C) that includes most of the interdiction targets and the less mobile elements of air defense does not in general require reporting during flight, and resolution below 5 feet is not required to obtain intelligence of major utility.

SPECIAL HANDLING

Consider now the capabilities of the various types of sensors answering these requirements. Figure 2-3 shows the resolution dependence on altitude of two typical cameras, an infrared imaging system, and high resolution side looking radar. The resolution as limited by a cathode ray tube dynamic display (priority viewer) and a flying spot scanner for readout from film in the aircraft are also shown. The delays of inflight processing for these sensors are as follows:

1. Photography (exposure to processed film) - 1 to 15 minutes.
2. Radar (reception to processed film) - 2 to 15 minutes first correlation.
3. IR (reception to transmission of video modulated signal) - effectively zero.

(NOTE: It is not considered feasible, in light of the 1967 cut-off for state-of-the-art to transmit raw radar data, because of bandwidth limitations.)

Examination of Fig. 2-3 and the above delay table shows that for Class A targets only the IR image former will meet all the requirements, and then only on a low altitude flight path. Resolution is limited by the viewer, which is required if near real time reporting is to be done. If line of sight limitations preclude the use of wideband data link, the one remaining method for achieving real time reporting of imagery is its presentation to the observer in the aircraft, with report by voice or narrowband link. This is a last resort, since the capability of the observer to perform this task is likely to be considerably less than when the observation is done on the carrier. The radar resolution falls short of that required for this class of targets, so that it cannot be expected to contribute much even when a delay of half an hour or more is tolerable. Since resolution achievable by photography is limited in this case by the scanner used to generate data link modulation, there is no improvement to be expected over the IR resolution, even when the processing delay can be tolerated.

For Class B targets, the IR sensor again answers best to the requirement for inflight transmission. As noted above, some amount of timely intelligence is deliverable after the aircraft lands on the carrier. Here, hard copy imagery

SPECIAL HANDLING

SPECIAL HANDLING

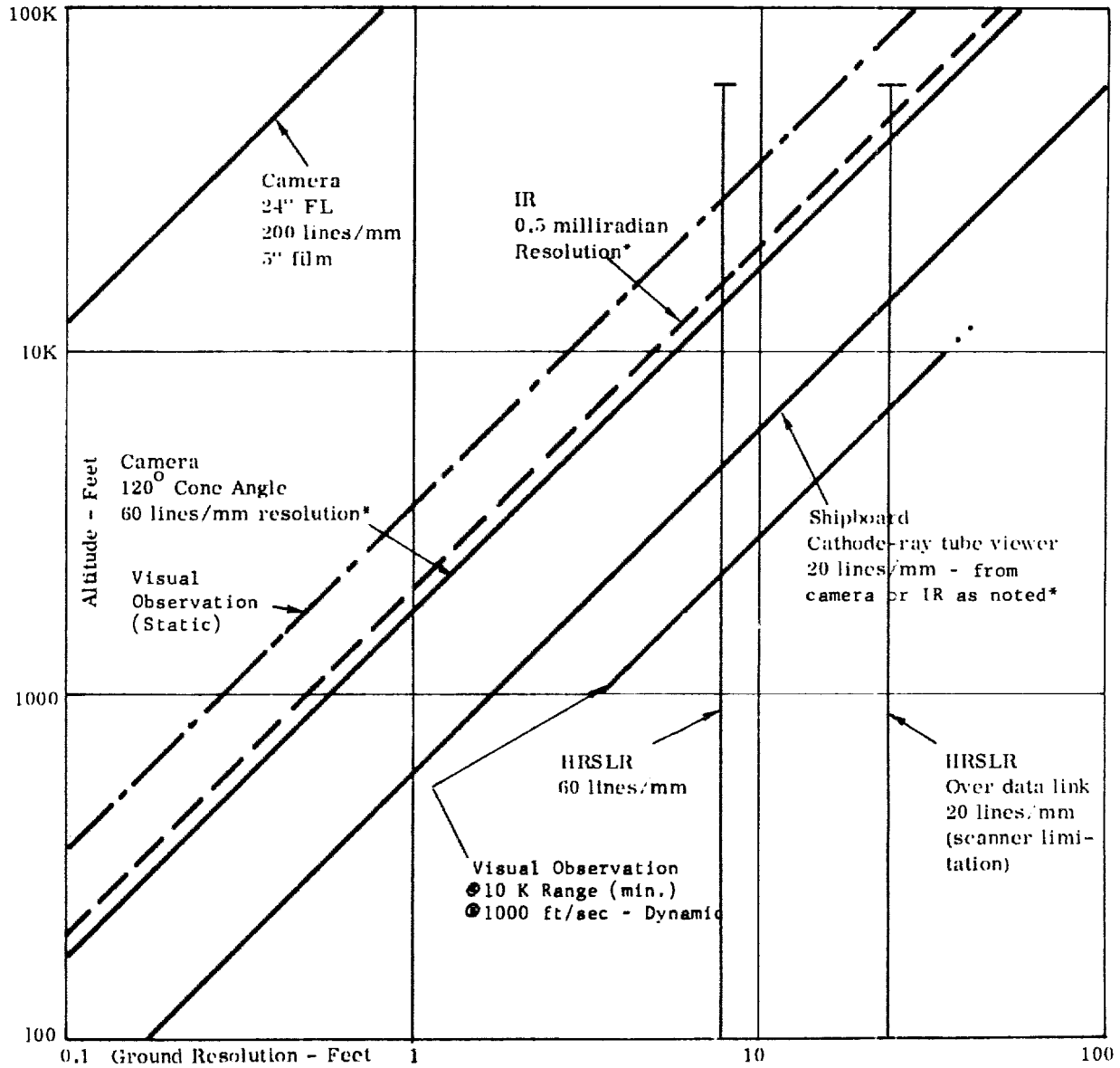

Fig. 2-3 — Imaging sensor

SPECIAL HANDLING

from all three sensors may be used in a cooperative way. Photography will satisfy all resolution requirements at both high and low altitudes, IR has limited capability at high altitude, and radar is limited at all altitudes. For Class C targets, all sensors provide usable resolution.

The final consideration relating to timeliness has to do with the time required for interpretation of the imagery aboard the carrier. Because of the large quantity of detail, this time is likely to be intolerably long. A strong requirement therefore exists for presorting the imagery hard copy to reduce substantially the amount of material that need be examined by the interpreters. This requirement can in large measure be met by the non-image data. The properties of high temperature and motion, while not having a one-to-one correspondence with the targets, do show a highly useful correlation. ELINT data is very highly correlated with priority targets. Thus, by keying the total imagery take with these data items, the time for interpretation can be very significantly reduced, and in some cases by orders of magnitude.

2.2 SENSOR INTEGRATION

Examination of sensor coordination and integration will first be discussed realizing of course that each of the five sensors has an outstanding capability not possessed by the others. Figure 2-4 indicates these functions, and it should be noted that although man has a spectral sensitivity which duplicates the photographic regime, no other device can recognize, identify and evaluate with the judgment possessed by an observer.

Briefly, the basic characteristics of the various sensors are as follows:

The observer and the photographic sensors, operating in the visual and/or near visual range, evaluate and record detail —

Observer - judgment, valuation, very limited data rate

Photography - shape and texture; limited by atmospheric conditions.

The IR sensors detect activity through heat radiation —

IR - imagery, good resolution, operative in darkness; limited by atmospheric conditions.

SPECIAL HANDLING

2-13

SPECIAL HANDLING

Sensor	Unique Capabilities							Basic Capabilities				Real Time Identif.
	Judgment	Emitters	Moving Targets	Hot Spots	Detail	Passive	All-weather	Long Range	Accurate Target Location			
Photo					X	X		X	X			
IR				X		X			X		X	
HRSLR			X					X	X		X	
ELINT		X				X					X	
Observer	X											X

Activity

Activity

Fig. 2-4 — Sensor capabilities

SPECIAL HANDLING

The SLR sensors detect moving and man-made objects through reflective characteristics —

SLR - imagery, poor resolution, operative in darkness, all weather operation foliage penetration; limited by poor resolution, specular reflections.

The ELINT sensors detect radiation from man-made emitters —

ELINT - long range, identification; limited locating ability.

The ability for real time target detection is automatic and inherent in IR, SLR, ELINT, and the observer; however, there is not such a capability for the photographic sensor due to the complex nature of the technology, and the complexity of the target characteristics. There is, however, the capability of rapid inflight processing and electronic readout, which together will enable, if desired, near real time evaluation of a record.

To be of increased value, a multisensor system must meet the obligations of data priority and timeliness of response as outlined previously. This is accomplished by integrating the individual sensor operations so that they function cooperatively to assist in sorting the data, and producing the necessary response. Integration alone is not the answer, even though the complementary data will permit extended evaluation. The sheer volume of data thus produced forms a more potent barrier to timely interpretation than any lack of data ever could. A technique must be found which enables the sensor array to achieve data priority selection, real time data reduction, and overall efficient data management.

A variety of techniques were investigated to evolve the data produced by an airborne multisensor system. Some of the basic methods considered were the following:

1. Cueing
2. Controlling
3. Pointing
4. Annotating
5. Display
6. Scaling
7. Moding
8. Screening
9. Targeting
10. Keying

SPECIAL HANDLING

SPECIAL HANDLING

There is a similiarity between some of these techniques which becomes evident in the following brief discussion. The system finally chosen has borrowed features from several to form the final configuration.

Cueing — A technique involving the alerting of one sensor by another so that features of the alerted sensor may be changed for maximum effectiveness (sensitivity, scale factor, focal length, etc.).

Controlling — An active cueing function wherein the alerted sensor is automatically changed by logic in the alerting sensor. This assumes an ability for target detection somewhat advanced beyond present capabilities.

Pointing — A controlling function in which the alerted sensor is not optimized but pointed in the direction of a detected alarm, thus utilizing very high resolution, small field systems rather than broad field systems.

Annotating — A technique in which the sensor alarm is recorded on the sensor record as a point indication, which calls special attention to that area during analysis.

Display — A system of converting imagery to an electronic or visual format for presentation in near real time. This can include simultaneous display of several sensor outputs.

Scaling — A technique of image manipulation to provide a common scale in the sensor records.

Moding — A technique for sensor operation which provides for effective sensor parameters with changing operating environments, such as high and low altitude operations. Simple parameter changes by the operator would be classed in this category.

Screening — A popular concept in which the alerting sensor causes a brief operation of the alerted sensor, this decreasing the data record volume to those areas in which an automatic alarm is sensed.

Targeting — A complex technique, requiring computer memory and manipulation, in which major tactical "targets" would have a multisensor "fingerprint", and the system would detect the signature and automatically annotate a record, precluding analysis. Thus the total multisensor output would be continuously monitored and the readout of targets computed automatically.

SPECIAL HANDLING

SPECIAL HANDLING

Keying — A composite technique in which a sensor threshold or alarm is annotated with an identifier and locator on each sensor record, and/or a separate, high density "key record" to promote quick evaluation of records for high priority areas in which sensor alarms have occurred. Since the value of the multisensor concept is inherent in this technique, this "combination of ingredients" scheme has great merit in providing an adaptive analysis method that is simple, and easily implemented.

The keying system correlates the alarm data capability of IR, SLR and ELINT with the precise detail available in the prime record - the photograph. It is an extremely flexible system which does not degrade the performance of any sensor, or rely on the proper operation of a particular sensor for continuity. The key system functions with one sensor, or any combination, with no preference or interdependence. Its greatest advantage is that the keys greatly facilitate the data management in surface based equipment.

The logic on which the selection of this concept has been made is now described.

1. The unique outputs from the IR, HRSLR and ELINT sensors (hot spots, moving targets and emitter activity) respectively are recognized as extremely important identification parameters for highly significant targets.
2. Each sensor by itself cannot always reliably identify and locate these significant targets from its unique output signal, nor can its output signal be easily correlated with photographic records.
3. If the unique high-priority signals from the observer, IR, HRSLR, and ELINT sensors are used to "key" the outputs from each other, and jointly to key the output from the photographic sensor, important targets will be highlighted from the viewpoint of all the sensors. False alarms can be reduced and unknown targets identified and located with a much higher degree of reliability.
4. The keying signals are the kind of information most useful to an observer in the aircraft in a "situation type" display. They are high-priority data, which have been heavily filtered by each sensor, and they are available in a useful format.

SPECIAL HANDLING

2-17

SPECIAL HANDLING

5. The keying signals, being activity-based signals (and not map-like imagery), consist of information whose content has a very low data rate and can be transmitted within a relatively narrow bandwidth. This information can be transmitted over standard high frequency (HF) air-to-ground links, and be available on the carrier in real time.

6. The low data rate key signals are of the type which can be readily encoded digitally and stored on tape. The tape, of course, is an ideal medium for the control of data link transmission, visual displays, and shipboard data management.

7. The key signals from the three sensors are similar in function to the keying signals which will be interjected by the observer in the aircraft. Therefore, comments and annotation by the observer (observer "keys") would also be entered on the key tape with the sensor keys to assist further in the sensor output correlation. These would likely be derived from operator's "pushbuttons", and would certainly be digitized for the tape, and for immediate transmission to the ground via the narrow band data link, since they normally would constitute high priority information.

2.3 OPTIMIZED MULTISENSOR SYSTEM UTILIZING KEYING

A block diagram of the airborne portion of the optimized multisensor system is illustrated in Fig. 2-5. As the signal flow paths in this diagram are reviewed, the advantages of the data integration keys, already discussed, will become even more apparent. In Fig. 2-5, the sensor signals originate on the left hand side of the diagram, the observer's display is at the lower right, and the data-link is in the upper right quadrant. The keying control tape is in the center of the diagram.

The margin burden of organization of material, and the basic steps in data management that make this concept workable, fall to the airborne system. The delineation of the methods which form the data management base is thus accomplished in the discussion of the data collection system.

As an aid to the interpretation of Fig. 2-5, it would be as well at this point to summarize the salient features of the optimized airborne system. No attempt is being made to delineate specific hardware, only the data flow, and basic configuration of the subsystems are shown.

SPECIAL HANDLING

SPECIAL HANDLING

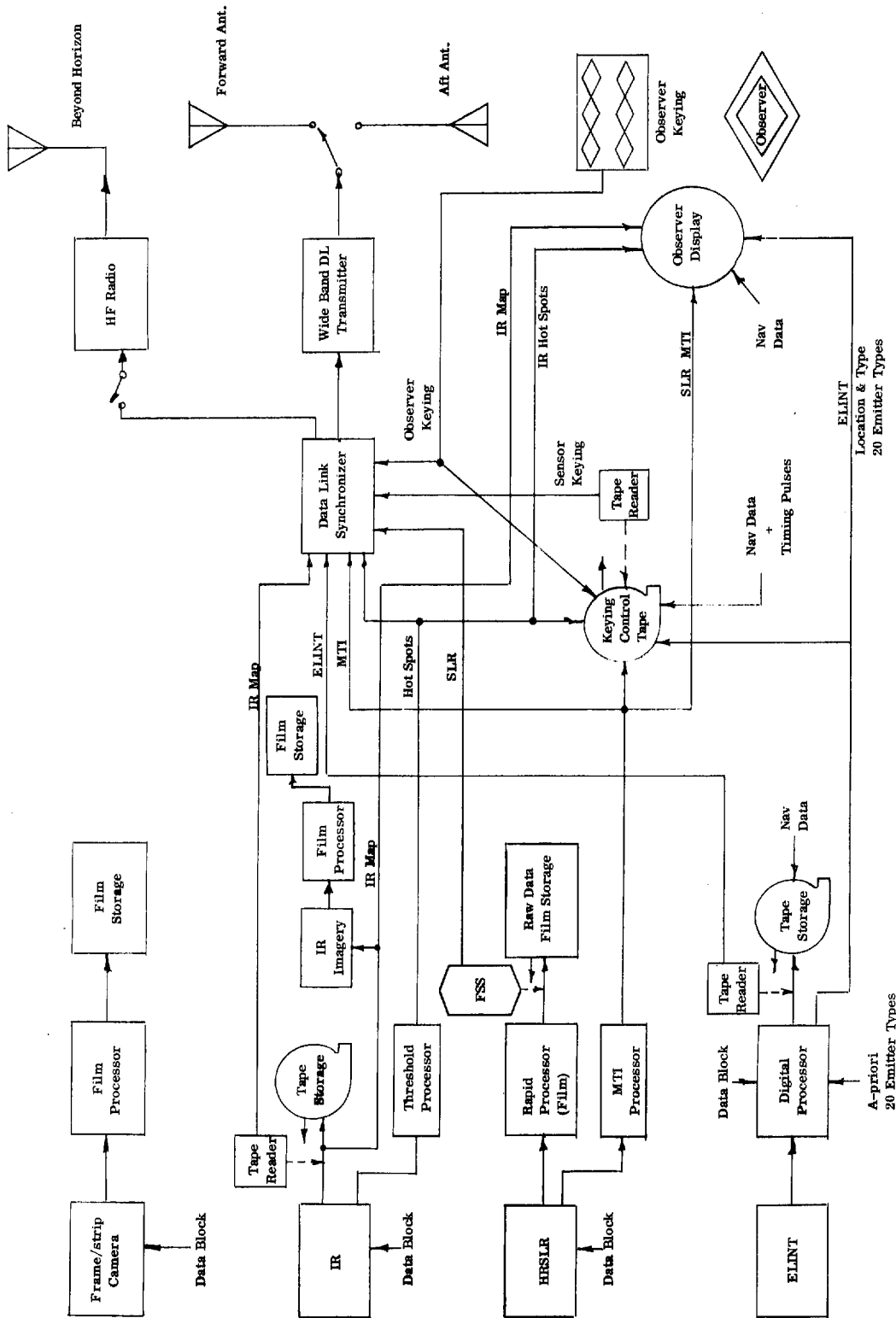

Fig. 2-5 — Airborne system concept

SPECIAL HANDLING

SPECIAL HANDLING

1. Keying of imagery by MTI and high reflectivity targets of the HRSLR, hot spots of the IR, emitters of ELINT and comments of the observer are to be the primary method of integrating the airborne sensors. Photographic sensors will not key any of the other sensors.

2. No cueing of one sensor by another will be done - sensor pointing will be fixed for all sensors, and the missions set up ahead of time to cover the target areas desired.

3. A "keying" or "control" tape will be generated in the air to store keys from the three sensors, and the observer, and allow them to be transmitted to ground via a data link. Keying data will be put on the same tape with navigational data and timing signals, so that the tape may be used in the air or on shipboard for complete sensor media synchronization.

4. Keying of the photographic, IR, HRSLR, and ELINT recording media will be done in parallel with the recording of the keys on the keying-control tape. However, because of the difficulty in obtaining the keys in precise real time, the keys placed on the imagery may be displaced from the proper nadir points. This will not alter the use of these imagery keys as a backup to the control tape, since both the keying and the imagery will be referenced to the airborne timing pulses.

5. The key/control tape could be used in the air to control the transmission of keyed data over the data link when the aircraft is returning, thus restricting the transmission to selected, highly-significant data.

6. Side looking radar will have an MTI processor so that MTI data in digital form will be available for keying, for the data link, and for the onboard observer's display. In the MTI mode, the HRSLR can look forward at approximately a 45-degree angle.

7. The IR sensor will have a real time output of thresholded hot spots for use in keying, display, and data transmission. The map image will also be provided to the observer's display for auxiliary navigation at night, etc., and also to the data link for transmission to the ground. An IR image will be recorded on film, using the tape readout as a source. This film is redundant but provides the prime IR image on film for the interpreter immediately on the return of the aircraft.

SPECIAL HANDLING

SPECIAL HANDLING

8. ELINT will use an onboard processor to provide real time identification and location data for a maximum of 20 emitter functional types. Data will go to the keying tape, data link, and observer's display. Data on all emitters intercepted will be stored on the magnetic tape.

9. The observer will be able to report on significant MTI, hot spots, or ELINT targets from real time displays presented to him. He will also have IR map display for auxiliary nighttime navigation, target location, etc.

10. The airborne observer's display is envisioned as a split optical viewer fed by superimposed sensor images and projected map/battle order synthetic image. The sensor images will be on a storage type of cathode-ray tube and will consist of ELINT type and location, IR thresholded hot spots, HRSLR, MTI targets, and an IR map display. An identical display is suggested for the Priority Analyst on the carrier.

11. Rather than using a microphone for reporting information, the observer will have a "pushbutton" keying device which will encode important data into digital codes for immediate transmission over the data link (or HF link), insertion on keying control tape, etc. These data will consist of the observer's evaluation of the overall situation and the progress of the mission, his confirmation of target identity, suggested actions, and any other information deemed necessary.

12. Limited mode switching of some of the sensors can be done by the observer.

13. A wide band data link will be provided to enable the IR map, the HRSLR data, and the processed ELINT data to be sent to the carrier in real time.

14. The data will be sent back on the data link in real time, if a line-of-sight path or relay exists, or on the return trip of the aircraft, if a line-of-sight path or the relay do not exist. Control of transmission will be at the discretion of the observer.

15. Transmission of the photographic sensor imagery over the data link will not be done. This because for the rapid assessment of real time imagery required on the carrier, the IR image would serve as well as the photographic

SPECIAL HANDLING

SPECIAL HANDLING

image. In addition, the IR map image is available at night, and conserves bandwidth in the data link. Processors will still be included with the cameras so that processing time can be saved onboard the carrier.

16. Since the keying and observer's report data occupy a relatively narrow bandwidth, they will be sent over the high frequency (HF) aircraft communication link, thereby providing a data transmission capability beyond the line of sight for the highest priority information.

Utilizing the background of system operation just presented, a more detailed examination of Fig. 2-5 is now in order. Starting with the camera sensors at the upper left hand corner of the diagram, it will be noted that the film output is processed immediately in the aircraft, but that no outputs are sent to the keying tape, observer's display, or the data link. There are a number of excellent reasons for the omissions. From the standpoint of keying, the photographic sensor cannot, within the present state-of-the-art, conveniently recognize targets and generate appropriate signals therefrom. Target recognition studies and development programs have been underway for a number of years and operational systems may someday become available, but not within the 1967 state-of-the-art. In this system, the photographic imagery will be keyed, but will not generate keys.

The photographic image is not sent to the observer's display because virtually the same information is available from the IR sensor as an electronic analog signal (IR map), and can be easily displayed. The IR sensor will have nearly the ground resolution capability of the camera, but for an observer's use in a real time situation display, it is not felt that the slight loss in resolution would be detrimental. It is interesting to note that an important added feature gained by the use of the IR signal for display is that it can "see" in the dark as well as in daylight.

Photographic transmission is not recommended since the IR image will suffice for rapid assessment of real time imagery on the ship and processed film will be back with the aircraft within an hour after it could have been sent back by the data link. Using the data link would force a minimum 3:1 resolution degradation due to readout.

SPECIAL HANDLING

The IR sensor stores the detail thermal mapping information on tape as shown, a resolution degraded image is read out for use in the display system, and a simultaneous high resolution film record is made. The tape is used for interpretation only when thermal detail, not recorded adequately on the film, is required. The IR imagery becomes high priority information when the time-liness factors of a target fall into a time period less than that required for the aircraft return. Thus the carrier-stored image will be extremely useful. The image display will also serve as an adjunct to navigation and flight path orientation. Either a vertical or forward looking IR image can be viewed at the operators choice.

Derivation of the HRSLR high resolution map requires the additional processing of film imagery by an optical correlator. Therefore the output from the HRSLR must be film, and the film must be processed rapidly before being scanned by a flying-spot scanner (FSS) and transmitted to the ground over the data link. The HRSLR MTI processor is a thresholding device, similar in function to the IR threshold processor, and produces moving target keys for the keying tape and observer's display. The data on this key are target velocity and heading, target cross range location, and time.

The ELINT sensor block located at the bottom left of Fig. 2-5 uses a small general purpose computer as its digital processor, and stores digital data from every emitter received on the airborne magnetic tape. Data processed by the computer for apriori targets of interest are sent from the computer in digital form to the keying tape and to the observer's display, similar to the priority keys from the IR and HRSLR sensors.

Before leaving the sensor blocks in Fig. 2-5, it should be pointed out that the tape readers and the flying-spot scanner used to remove data from the sensor records and keying tape are configured to permit immediate readout as the data are being stored and also, to permit readout of the data later in the flight. This feature is deemed necessary to permit transmission by the data link after the intelligence mission is completed and the aircraft is on its return to the carrier.

SPECIAL HANDLING

2-23

SPECIAL HANDLING

Two data links are shown in Fig. 2-5. The wideband data link is the primary link for all data sent from the multisensor system, and will be used for that purpose whenever there is a satisfactory propagation path from the reconnaissance aircraft to the carrier (either line-of-sight or a suitable relay). The narrowband link represents one of the standard communication links provided with the reconnaissance aircraft. A link in the HF region is recommended since it can provide a beyond-the-horizon capability for the transmission of high priority data. This link is only to be used when the primary wideband link is unusable, and, because of the bandwidth limitations, can only handle the observer's keys, and the data from the keying tape, if required.

The concept on which the solution to the problem of handling multisensor data is based has been delineated in general. Now to illustrate the concept, the typical sensors and their parameters will be briefly outlined with a justification for each.

2.4 TYPICAL SENSORS AND THEIR PARAMETERS

For adaptive analysis, there is a requirement for wide, high resolution coverage from each sensor, over as large an area as is required by the mission. A parallel need is the reduction of the number of records to be handled, without reducing their data content. Where possible, high acuity systems covering a wider angle than normal are specified, particularly to maintain correlative cover for the keying system.

The sensor systems will be laid out by technology showing the coverage and typical performance required from each.

2.5 OBSERVER

The role of man in exercising judgment against the key system, and performing correlation on a limited basis, justifies expenditure of some effort in providing a clear forward and limited side view for the observer. This indicates that a side by side seating arrangement is preferable if the man is to perform any valuable evaluation of the passing scene.

SPECIAL HANDLING

The limitations of the observer are based on some very real visual limits. Moving targets further degrade ground resolution with the following general relationships.

1. Visual Ground Resolution — Under static conditions human vision has about 1 minute of arc resolution on high contrast targets - this is equivalent to 4 inches at 1000 feet distance.

2. Motion Limits — Dynamic conditions impose severe restrictions on human vision. When a relative motion greater than 6 to 8 degrees per second exists, human vision is impaired, leading to nausea or disorientation. It is necessary then to extend the target range to the point where the relative motion is less than 8 degrees per second. At 1000 feet altitude, traveling at 1000 feet per second (Mach 1) a minimum range for useful vision is 10,000 feet. Therefore the ground resolution becomes 3 feet apparent, which at low obliquity may mean 30 feet on the ground. (The range refers only to the distance from the observer to the target on a direct line.)

It can be seen from this treatment that clear forward view is vital for low level observation, with the side view becoming more important and feasible as altitude increases.

2.6 PHOTOGRAPHY

In keeping with the concept of reducing the record count, the sensors outlined in the following paragraph have been selected as typical of the requirements.

2.6.1 Low Level Operational Envelope

2.6.1.1 Forward Oblique

Constant scale panoramic camera with an f/3.5, 2 to 4-inch zoom lens using 70 millimeter film. This camera will have a 120-degree cross-track scan and 60-degrees along the flight line set at a 25-degree depression angle. The ground resolution will be 1.2 feet from 500 feet to 1000 feet per second.

SPECIAL HANDLING

SPECIAL HANDLING

The forward oblique coverage is wider than normal, emphasizing the additional coverage judged valuable in this position. The forward oblique in tactical use is felt by many to be the most valuable single camera for low level work.

2.6.1.2 Vertical

Frame/strip camera with T/8, 1.75-inch Super Aviogon lens using 5-inch film. This convertible camera will have a strip or stereo frame capability covering 110-degrees cross-track and 110-degrees along the flight line. The ground resolution from 500 feet at 1000 feet per second will be 4 inches at nadir, and less than 12 inches at the edge of the format.

The wide angle frame camera will provide maximum coverage with a single record, and still maintain simplicity. Stereo is available from adjacent frames when 55 percent overlap is used. The coverage is designed to coincide with the coverage of the vertical IR sensor, which will have virtually the same ground resolution.

2.6.1.3 Vertical

Panoramic camera with f/3.5, 3-inch focal length lens on 70 millimeter film. This camera will have a 180-degree cross-track coverage, and cover 40-degrees along-track. The ground resolution will be less than 12 inches from 500 feet at 1000 feet per second.

This camera is selected to provide near horizon coverage which will correspond with the coverage of the IR hot spot detector, the SLR and the ELINT, along the flight line, without need for scale conversion. It is particularly needed since the key system is based on the flight line cross-track coordinate system, and horizon-to-horizon photographic coverage on one record will be useful in correlation.

2.6.1.4 Side Oblique

Frame camera with a f/2.8, 6-inch lens using 5-inch film. This camera will complete the fan array with the vertical - with a 40-degree field cross-track and a 40-degree field along-track set at a 20-degree depression angle. The ground resolution of this camera will be 6 inches on axis.

SPECIAL HANDLING

This camera is suggested for fulfilling beach running and road survey missions, and as a prime oblique record for tactical analysis along the flight path. It can be used as correlative material, with the other sensors, with scale adjustment.

2.6.2 High Level Operational Envelope

2.6.2.1 Vertical

Constant scale panoramic camera with f/3.5, 6 to 12-inch zoom lens using 70 millimeter film. This camera will provide high level basic mapping cover with a 120-degree cross-track and 20-degree coverage along the flight line. From 60,000 feet at a velocity of 2000 feet per second, a ground resolution of 6 to 8 feet can be expected across the entire format.

This camera is intended to provide reference imagery, with wide coverage without the penalty of weight and need for high light level common with high altitude wide angle frame cameras. The camera can be set up to cover up to 140-150° cross-track, should this be desirable.

2.6.2.2 Vertical

Panoramic camera with f/3.5, 24-inch Petzval lens using 5-inch film. This camera will provide high level detail, with a ground resolution of 9 inches from 60,000 feet at 2000 feet per second. The coverage is selected for 90-degree cross-track (20 nautical mile swath) and 10 degrees along-track to maintain high resolution imagery. Scale changes and atmospheric effects beyond a 45-degree elevation angle will degrade the imagery, and the swath width is judged adequate for tactical use at the 90-degree field angle. For operational requirements where extreme coverage is mandatory, this camera can be utilized up to 140-150° cross-track coverage with some resolution degradation.

Stereo coverage is possible from either high altitude camera by use of 55 percent overlap. The constant scale camera also is useful as a mid-altitude camera down to 5000 feet altitude, and the 24-inch pan camera is useful down to 10,000 feet, filling the midrange requirements if such operations should be needed.

SPECIAL HANDLING

SPECIAL HANDLING

2.6.3 Optional Photo Systems

2.6.3.1 High Altitude

Stand-off camera - this is a pod-mounted external system employing long focal length optics and stabilizing mounts to allow 70 to 100 nautical miles stand-off photography. This system is an add-on since there is no justification for carrying rarely needed equipment on the normal mission.

2.6.3.2 Low Altitude

Additional 1.75-inch focal length frame cameras, vertical - An additional two cameras for identical coverage on spectrally separated black and white high resolution coverage. This configuration would provide additive color and camouflage detection color (near IR) in a simple operational system requiring no special color processing equipment. Color has proven to be an invaluable tactical tool as detailed in the final report.

The photographic systems are considered to provide the prime image records. They produce the best detail, and the images fall into more familiar recognition patterns. For data management purposes, all imagery will be processed on aircraft to be available immediately as transparent positives on recovery. The very high resolution films will be viewed in the negative for fast work, and duplicated for leisurely interpretation due to processing limitations.

2.7 INFRARED (IR)

The infrared sensors will produce imagery and detail thermal patterns to reinforce the photographic system, and to make records under cover of darkness. It is expected that most night reconnaissance will be done with IR, but that an electronic illumination system will be provided for photographic detail if required.

The IR system is configured for a low and high altitude envelope simultaneously.

SPECIAL HANDLING

SPECIAL HANDLING

2.7.1 Vertical

A multidetector "sweep broom" array utilizing an f/8, 80-inch optical system and a rotating mirror scanning system. The sensor will record on 2-inch video tape, and has a potential ground resolution of 0.25 milliradians or 3 inches at 500 feet altitude and a speed of 1000 feet per second. The resolution limit is 0.125 milliradians for use at high altitudes where image blur (V/h) is not a major factor. Thus at 60,000 feet, the ground resolution is 7 1/2 feet, comparing directly with the corresponding photographic system. The IR sensor will have a cross-track coverage of 120 degrees and produce a strip record. In addition, the sensor will produce hot spot indicators out to 170-degrees cross-track coverage.

2.7.2 Forward Oblique

A multidetector array, used in "push broom" fashion will be mounted in the forward oblique position. It will utilize an f/8 optical system and has a dynamic resolution of 1 milliradian or about 1 1/2 feet, a direct correlation with the photographic system. The IR system, however, is limited to a 90-degree cross-track coverage. The value of the forward oblique imagery has been established, and this system provides for optional observer display and real time relay.

The IR system will be used to generate "hot spot" keys by thresholding in a signal processor. The record tape will be read out to produce an IR image on film by modulating a light source. That imagery will be the prime IR RECORD FOR INTERPRETATION, with the tape detail available for interpretation in depth. The thermal sensitivity of the sensors is about 1°C.

Either IR image can be presented on the operator display, and either can be transmitted in real time. The images are recorded simultaneously on the IR tape record.

2.8 HIGH RESOLUTION SIDE LOOKING RADAR (HRSLR)

The radar system is independent of altitude for function, and produces imagery and more important, MTI (moving target indication) data for the key system.

SPECIAL HANDLING

SPECIAL HANDLING

2.8.1 Vertical

A side looking radar system utilizing a synthetic array antenna, and coherent beam techniques. Of the sensors recommended, this system is the most advanced, and the ground resolution is dependent on the operational era. Current systems (AN/APQ-108) can resolve 8 feet out to 100 nautical miles, with 1970 era systems capable of 2 feet at 50 nautical miles and 8 feet at 100 nautical miles. The cross-track coverage of the HRSLR is from 30 degrees to 97 degrees elevation - with degraded resolution from 5 to 30 degrees.

The MTI capability will utilize a cross-track scan or a 45 degree forward "squint" for more efficient determinations. The movement detection is about 4 miles per hour cross-track and 10 miles per hour along-track with a directional vector determined above 15 miles per hour. The processed key information will be available about 1 to 2 seconds after detection in the squint mode.

The imagery produced by a synthetic array system requires an intermediary imaging and optical correlation step. The first image is formed on the aircraft on 5-inch film, processed, and read out over a data link if imagery is required quickly. The aircraft system for optical correlation is not justifiable on the basis of the operational analysis and timeliness criteria.

An optional foliage penetration system, as an external pod system, is suggested for that special purpose task. The frequency requirements are such that the same system cannot perform imagery and foliage penetration effectively.

2.9 ELINT

The ELINT system is independent of altitude, and operates passively, limited by the radio horizon. The system also provides key data, through an airborne computer processing step.

The ELINT sensor consists of an array of antenna collectors, each tuned to a different frequency range. The total range for this system is 60 megacycles to 18 gigacycles, which encompasses all the currently known hostile radars. By computed triangulation of signal intensity as received by the antenna array, the ELINT system is capable of locating an emitter to within 3 percent of its range to the aircraft. The location and emitter type computed on the aircraft are the

SPECIAL HANDLING

keys processed for the display and key system. The total ELINT record is maintained on magnetic tape for analysis at leisure for new emitters and other manifestations.

Conventionally, ELINT is a "side looking" device, covering a sector from 45 degrees aft. For the tactical mission, especially at low level, a forward looking system has been incorporated, so that the system can now be warned of emitters ahead, an important survival feature for the electronic countermeasure components, and an important coverage area for the reconnaissance mission, correlating with the forward oblique sensors of IR and photo.

The ELINT data will identify 20 basic emitters and can be programmed against any combination of emitters prior to a mission. These 20 emitters cover all known tactical systems adequately, not allowing for special purpose sorties. An airborne computer will be required for the ELINT system, and it will be cross-utilized by the display system and navigation system for airborne computations and integration of key data.

2.10 KEY SYSTEM

In order that data management can be controlled, and a two-hour data analysis period can be maintained, the key system has been instituted. As noted, judgment indicates that potential danger exists in neglecting ground areas not causing alarms in automatic equipment. Therefore, a complete ground coverage with annotations of alarms is considered safer from tactical surprise, and easier to manage because of coherence and easy correlation from all sensors.

The key system is briefly a record, on the margin of each record, and on a separate "key and control" record of an alarm from an IR hot spot, an SLR MTI signal, an ELINT detected emitter, or an observer report on visual detection of screened data or visual sightings. The data analysis, whether in real time by a "priority analyst" or on return of the aircraft, is made against the key annotations. The keys are noted on each record so that manual backup analysis without special equipment can be made on a simple light table.

The keys are generated as follows:

1. Photo - none
2. Observer - activity, identification, shape, texture

SPECIAL HANDLING

SPECIAL HANDLING

3. IR - temperature (threshold adjustable to 1°C), location
4. ELINT - emitter identification, location
5. HRSLR - MTI (speed and vector), location (2 second delay at 45 degree squint)

Each key is noted as an 18-bit digital word, man readable, giving sensor, location, and time. All records are correlated against a time standard, thus reducing location confusion.

A key and control record separate from all other records is made on magnetic tape. It contains a separate channel for each key and the observer comments, as well as time, and location from the navigation system. This tape is used in the viewer to allow control of the records, and recall against the keys, thus eliminating the need for a film reader in the viewer, where occasional overlap of keys could result from extremely high density alarms.

2.11 DISPLAY SYSTEM

A practical, simple, display system has been selected for the operator/observer, which presents only screened, high density information to relieve the strain of high data presentation rates. The keys are displayed as a symbol, in proper location, overlaid on a moving map image, on which the aircraft is correctly located. The map is a current order of battle status map, so that new alarms can readily be distinguished from old. It is automatically scaled for altitude, and has a momentary stop action mode as needed. An IR image from either the forward looking, or the vertical system can be overlaid on the map for gross analysis, or navigational updating. This mode will be particularly useful for low level night reconnaissance, for both the operator, and the aircraft commander.

The operator/observer will use a simple coded report keyboard to annotate the key record, and that key record will be read out in real time over the HF data link (not horizon limited). The data links, if both are operative, will allow a complete replay of the display for the priority analyst on the carrier. If the HF link alone is operative, the display without imagery will be in real time allowing cumulative plot of the keys and determination of detail analysis priority.

SPECIAL HANDLING

2.12 DATA MANAGEMENT

The basic problem in multisensor reconnaissance can be classed as a data management problem, as the collection methods are well established. The multi-sensor theory contends that corroborative data on the same area will reinforce, and ease the interpretive effort with reference to a given target. This is true; however, the multiplicity of records on the same target inserts a complexity into the management of data, to maintain quick, timely analysis. The key system is an important part of the concept which provides for timely data handling. The other basic points of the system are outlined here.

2.13 DATA PREPARATION

In order that all records be available on return of the aircraft, thus eliminating ground processing delays, all image records will be airborne processed. The photographic sensors will each have processing magazines, producing negatives and transparent positives ready for immediate use. The negatives will remain as backup spooled records, and the positives, usually of adequate resolution (maximum 80 lines per millimeter) will become the viewing record.

The infrared images, formed on film in the aircraft will be processed in a like manner, and be available as positive transparencies. The IR tape record will be maintained for use as required for detail temperature data, not recordable film.

The HRSLR record will be handled differently to conserve weight and space on the aircraft. The operational analysis indicates that a delay from real time is acceptable for the SLR image, due to its low comparable resolution. Therefore the first data reduction, a non image photo record, will be made on the aircraft processed, read out and relayed on the wideband data link for optical correlation on the carrier, where the imagery will be produced. This record then will be available on return of the aircraft as a second generation positive transparency.

The ELINT record will be maintained as a backup tape record, with the prime ELINT data processed into the key and control record tape. The ELINT tape will be processed for new emitters by the carrier-based computer systems.

SPECIAL HANDLING

2-33

SPECIAL HANDLING

The key and control tape, containing all the key annotations, is available as a complete separate record, both as an airborne record and as a relayed record maintained on the carrier for backup. Either record tape will be read into a disc storage system for use in cumulative plots of the aircraft progress and key alarms. The disc storage system will also maintain order of battle (OB) status and ELINT data for ECM systems on a quick access/change format for use by several downstream systems.

2.14 PRIORITY ANALYSIS

The first innovation in the data management concept involves the use of a real time analyst. This individual will monitor the key and display records relayed in real time. As noted, this may include imagery if the wideband data link is operative.

The priority analyst has two functions.

First, he will evaluate the key alarms for target activity levels. This will be done against an order of battle (OB) status map in real time, a duplicate of the airborne display, and a cumulative plot. This will possibly generate new status information, but definitely will allow programming of the analysis of the prime records. Second, the priority analyst may be able to evaluate IR imagery, which can be recorded and replayed if desired, for real time order of battle (OB) status information. The data rate, which is the limit of man's real time evaluation capability, is limited to 5 to 10 bits per second, thus generating the need for prescreening data for real time use. Without this feature, the man is overloaded and rapidly falls behind the real time situation to the point where the evaluation breaks down.

Since the analyst working in "real time" cannot use imagery, a second operator should be associated with the priority analysis whose sole function is relayed imagery evaluation. This analyst may utilize the IR imagery, either forward oblique or vertical, or a selective video presentation keyed to a sector of the real time display by either the analyst or the airborne operator. Thus the capability to work with limited imagery is incorporated, allowing target and opportune sighting evaluation.

SPECIAL HANDLING

The records used by the priority analyst, those relayed over the data links, are secondary records, and consist of the key and control record and degraded IR imagery. The SLR record relayed for processing only, is also available should the aircraft fail to return.

2.15 MISSION ANALYSIS

The next critical phase of data management occurs in the preparation for and analysis of the prime records. As shown by the operational analysis, time here is critical, so that command decisions can be timely, and based on confirmed data. The records for analysis consist of the total record take of the aircraft:

1. Photography - positive imagery from 7 cameras
2. IR - positive imagery from 2 sensors
3. HRSLR - positive imagery from 1 sensor
4. ELINT - emitter plot
5. KEY AND CONTROL - key annotations and time/navigation data

Each image record will redundantly carry the key annotations from all alarms should manual viewing be required.

There is need for reference imagery and text to establish a data base for updating, and to allow change detection, which is the critical parameter. The "historical" imagery and text will be maintained in aperture and file form for quick retrieval. A card deck, representing the imagery and text required for the analysis will be assembled on the basis of: 1) the assigned flight path and target areas, and 2) the activity and real flight path as determined by the priority analyst. Records will be maintained, and computer indexed by geographic coordinates and target type. The card system will maintain imagery in the original format (70 millimeters or 5 inch) to reduce handling problems under extreme time pressure. Text and reference material will be format reduced to microfile and standard microstorage systems, but maintained in the 6 by 9-inch standard aperture card as is the imagery.

An order of battle (OB) plot and overlaid key plot will be maintained, with aircraft location as determined from the key and control tape or the imagery data blocks for use as reference for the analysts.

SPECIAL HANDLING

2-35

SPECIAL HANDLING

2.16 VIEWING SYSTEM

The heart of the analysis system will be the viewer. The viewer should have the following major capabilities:

1. Two analyst stations
2. Two prime viewing screens
3. Two reference viewing screens
4. Ten parallel image channels with operator selection (five for each screen)
5. Stereo capabilities with binocular view module on two channels only
6. Key and control tape for target or areal selection
7. Tie-in with computer for mensuration and data index information

Associated with the viewer, but not a part of it, should be the key and order of battle (OB) plot and aircraft location indicator. The operation of this viewer complex will be on the following basis.

From the order of battle (OB) plot, an analysis area will be selected, and a computer identification of the index code will be established from coordinate read-out. The reference card deck, in the viewer will be searched and the last imagery presented on the reference screen, the key tape will be searched for the same reference, and the records slewed to the proper area by data block time read out. The analyst can optically select the prime record photograph, IR, SLR; etc., read the keys from the tape A/N display and make an interpretation in a short time. If required a simultaneous record can be switched to the other view screen for point to point comparison. Image magnification from 4X to 20X will be required as well as image rotation capability for orientation purposes (as with panoramic coverage versus frame coverage).

The analyst will make his report and requests orally to avoid delays, and an operator associated with him will communicate with the automatic systems with conventional keyboard systems. A computer will be utilized to perform mensuration conversions and communicate with the disc storage, and index reference systems.

SPECIAL HANDLING

A punchcard backup will be generated for the disc and index stores, as part of the reporting cycle. The new order of battle (OB) status or detail reports can be automatically plotted on the flag order of battle (OB) display, or they can be manually posted there from the punchcard readout.

2.17 DATA STORAGE AND RETRIEVAL

The data base update, provided by the new intelligence will take two basic forms. First will be the selection of the new imagery by the analyst from the sortie records. Second will be the selection of the order of battle (OB) status reports, in punchcard, text and disc file format.

The new imagery will be directly placed in the aperture card system and filed as original imagery in an index system for manual retrieval on call. The card file backup will be automatically sorted and stored to back up the fast access disc storage systems. By maintaining the original image format, several advantages occur. The manipulations of reduction, processing, storage, and reproduction are eliminated, and image resolution is not degraded as is inevitable with duplication processes.

Original negatives in spool storage, will be retained for duplication and archival uses as required, only for such periods as are reasonable, due to the time perishability in a dynamic environment.

The magnetic tape records will be stored for 36 hours then erased and reused.

2.18 MISSION MATERIALS

The materials for mission folders will be extracted from the imagery files and disc storage printouts and provided as hard copy along with maps and target lists.

SPECIAL HANDLING

2-37

SPECIAL HANDLING

Conclusions

The concept outlined above has been gaged to fulfill the intelligence requirements of the operational analysis. It is based on collecting all available data, and screening it by use of key annotations generated uniquely by the observer, and the IR, ELINT and SLR systems. It provides for aircraft display of important data and real time relay of priority information to the carrier.

The concept provides a system of data analysis utilizing a minimum of records, and the key information. The interface with automatic data handling equipment is limited to speed up functions, which do not in any way attempt evaluation or decision making.

The storage system is based on a minimum of manipulations, and utilizes the human capability for rapid random access.

SPECIAL HANDLING

3. MISSION PARAMETERS

In developing the system concept, a basic environment has been used that specifies the conditions in which the system must operate, and the requirements which it must fulfill. These represent as realistic an operational environment as is possible, with the parameters based on the reconnaissance doctrine discussed in Volume 1, Naval Doctrine.

1. Reconnaissance Support of the Task Force — The system must perform all the reconnaissance for the task force regardless of the operation, ranging from peaceful maneuvers to total combat support.
2. Self Contained — The system must operate alone, and perform all collection and interpretation with no support outside the task force.
3. Reconnaissance Aircraft — The system will be based on a 6 to 8 vehicle complement, and assumes that only one carrier is so equipped. Further, the aircraft are specially configured for multisensor reconnaissance, and are not assigned any other function.
4. Targets Assigned — It is assumed that each reconnaissance sortie is assigned between 10 and 20 targets, and that further "targets of opportunity" will be recorded on the judgment of the observer.
5. Simultaneous Sorties — A maximum of 2 sorties will be simultaneous and 1 sortie in the air at all times will be standard procedure under normal conditions.
6. Sortie Cycle — The launch/retrieve cycle will be 2 hours, with a launch occurring at each retrieval.
7. Interpretation Cycle — The information recovered from a sortie should influence the targeting of the next-off sortie, thus a maximum interpretation time of 2 hours from touch-down is assumed.

SPECIAL HANDLING

3-1

SPECIAL HANDLING

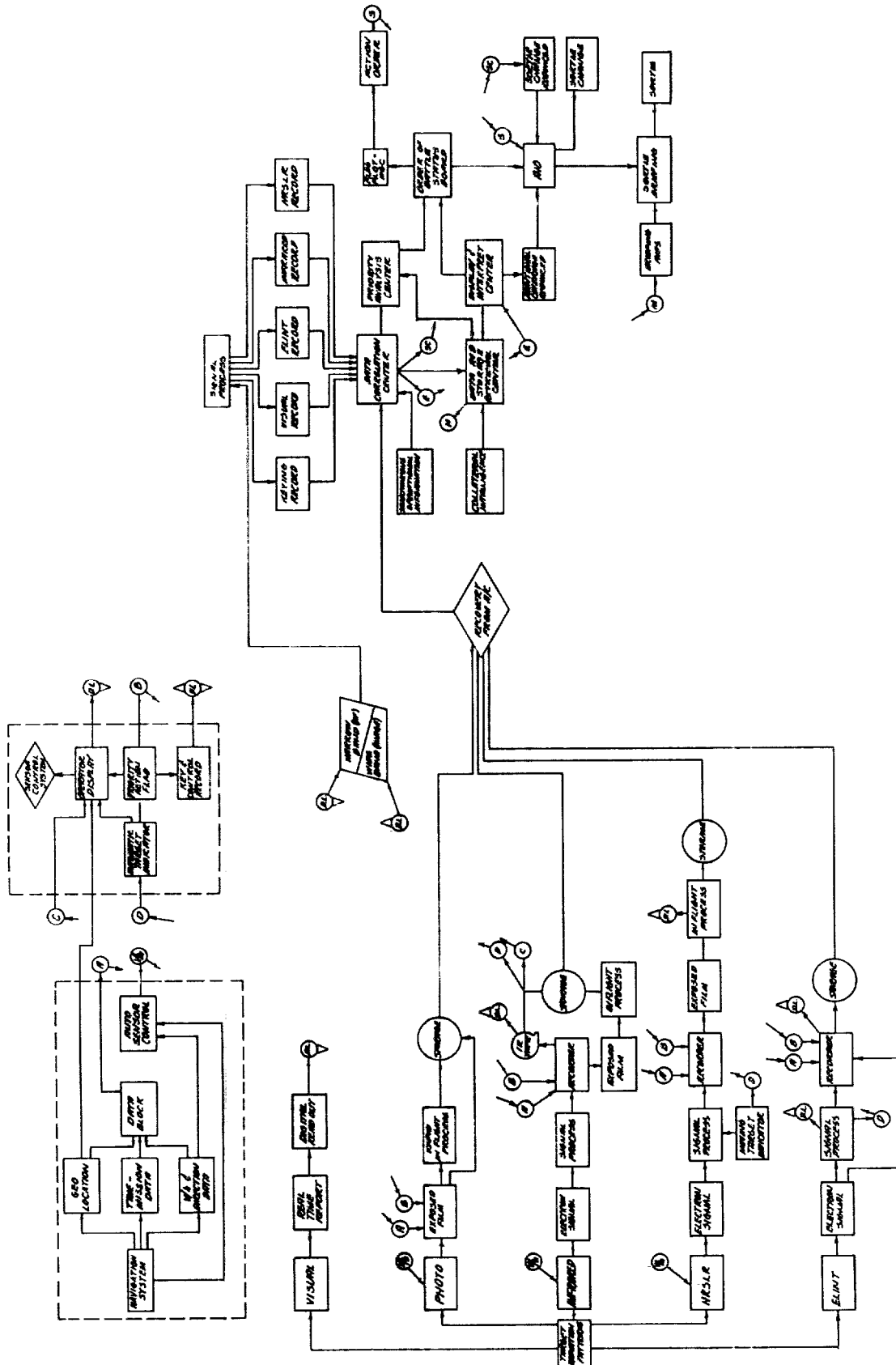

A. Multisensor Block Diagram

SPECIAL HANDLING

SPECIAL HANDLING

4. OPTIMIZED MULTISENSOR SYSTEM

4.1 TARGET DATA GATHERING REQUIREMENTS

In any complex system, the input characteristics heavily affect the design concept of the system. The considerations on which the conclusions reached here are based are discussed in detail in Volume 2, Target Characteristics, and the results are further delineated in this section. Each sensor is evaluated for its ideal environment, but it must be realized that any deviation from this condition will modify the results.

The requirement on the system for technical detail on request, and tactical Order of Battle data under all circumstances leads to the conclusion that each sensor must operate to its maximum capability. The basic system concept is shown in Block Diagram A.

4.1.1 Photography

The study of target characteristics, and the comparison of sensor systems resolution capability, leads to the realization that photographic imagery will provide the most detailed information on a target, regardless of the altitude or speed of the aircraft.

The photographic systems, recording in the visual and near visual spectrum, are passive sensors since they utilize reflected light for forming images. Normally, of course, that light is solar radiation, and good quality images can be produced at light levels as low as 100 foot lamberts. In the absence of solar illumination, photographic systems require either electronic light amplification (passive) or artificial illumination (active).

Since the multisensor system has infrared sensors, which require no illuminant source for producing imagery, light amplification systems can be considered redundant. The IR systems can produce an image of the same resolution as that

SPECIAL HANDLING

4-1

SPECIAL HANDLING

is produced with light amplification systems, thus eliminating the latter from consideration at this time.

The use of artificial illumination systems should be restricted in the multi-sensor system to those situations where low altitude detail is required which cannot be recorded by the infrared system. In order to minimize logistic and pyrotechnic problems, the use of electronic flash systems is recommended. The loss of shadow detail will result, and the system will be restricted to low altitude (below 1500 feet), but it is not anticipated that the flash mode for night reconnaissance will be a major system because of the presence of the wide range infrared systems which fill most night requirements in combination with HRSLR and ELINT.

The available solar illumination for photography can be illustrated by the illuminance charts shown in Figs. 4-1, 4-2, 4-3 and 4-4. The reflected radiation useful for near visual UV and IR photography is restricted by absorption characteristics of the atmosphere as shown in Fig. 4-5. However, dye sensitized silver halide emulsions are available which have sensitivity in the near visual ranges so that the range from 300 millimicrons to 1.2 microns can be used to form images on aerial photographic films.

The selection and use of photographic films for aerial photography is not discussed in this report; however, "Photographic Considerations for Aerospace" published by Itek treats this subject in detail. The factors which affect the selection are basic, and are as follows:

- Illumination
- Lens characteristics (f/number)
- Spectral range
- Atmospheric factors
- Exposure time
- System motion

As a basis then for the evaluation of data requirements for the photographic system, there is established adequate illumination and proper film selection, based on the mission parameters. The analyst should be provided with photographs having a resolution level determined by the task. The primary requirement of the analyst is to generate an order of battle status; detailed interpretation may be

SPECIAL HANDLING

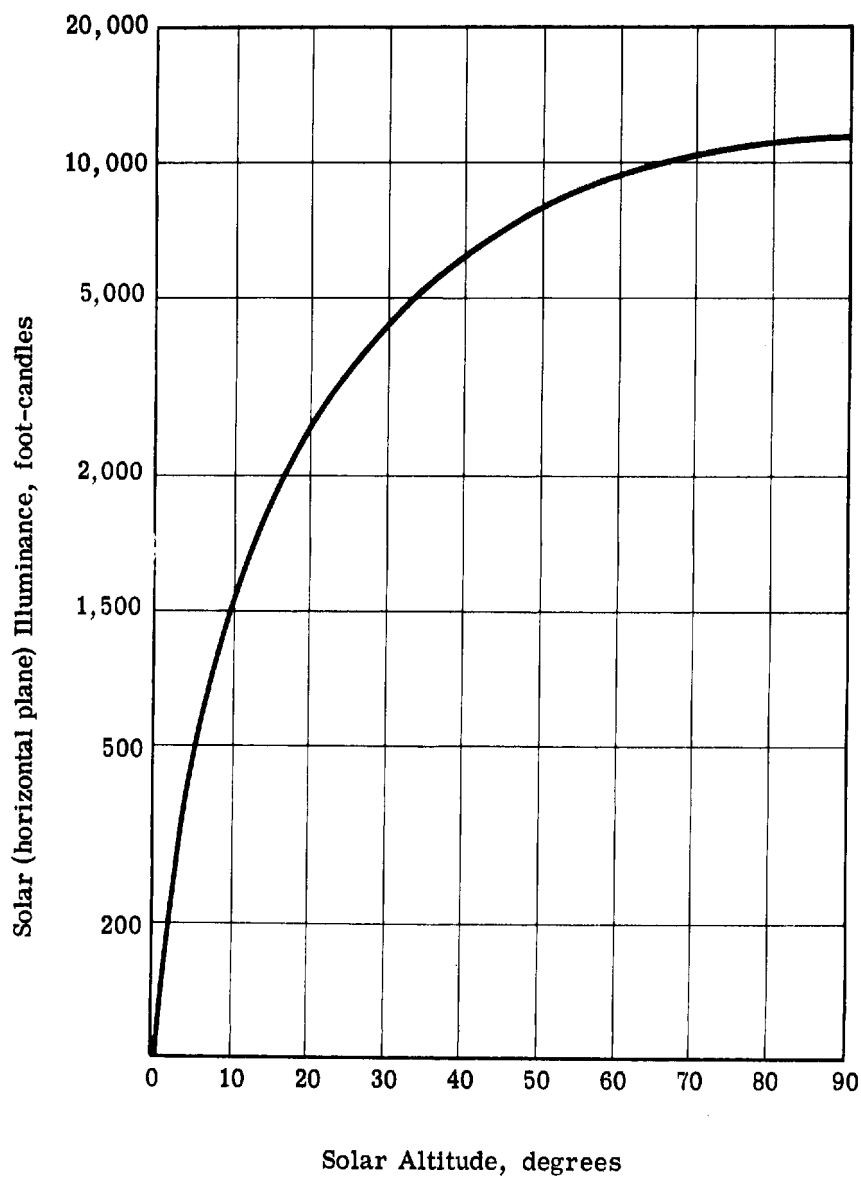

Fig. 4-1 — Solar horizontal plane illuminance as a function of solar altitude in average clear weather

SPECIAL HANDLING

SPECIAL HANDLING

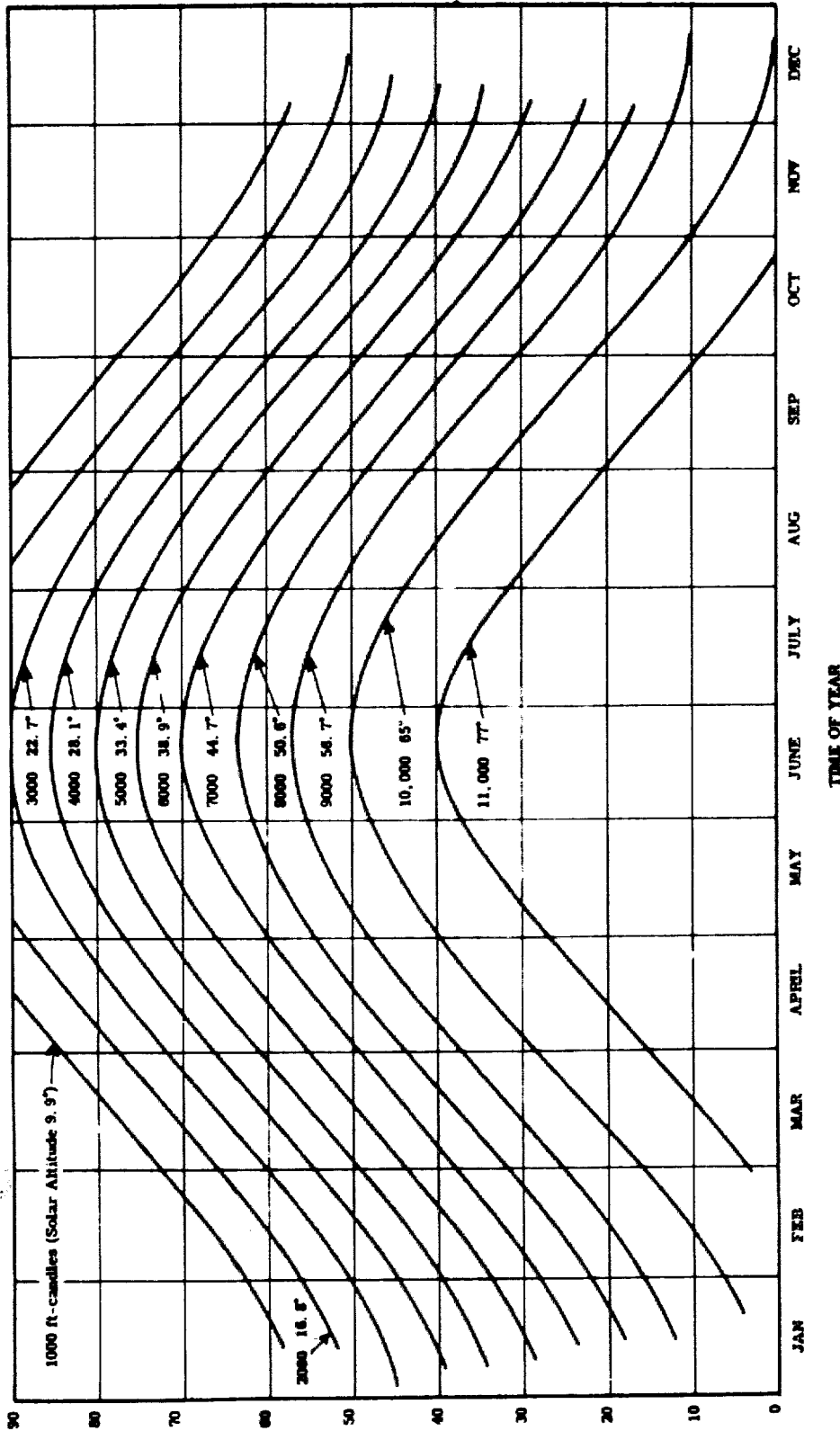

Fig. 4-2 — Constant solar horizontal plane illuminance as a function of north latitude and time of year (time: local apparent noon)

SPECIAL HANDLING

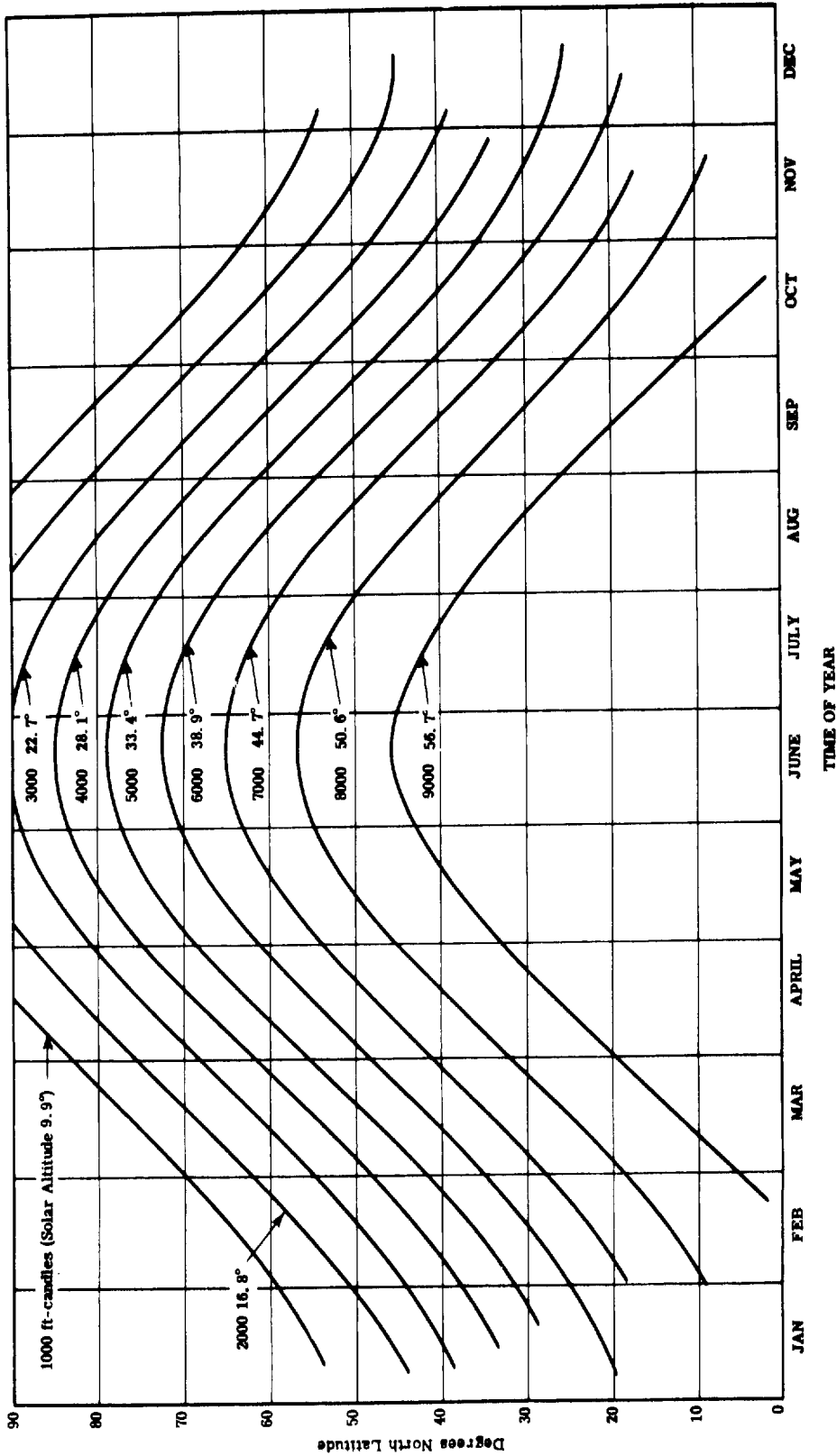

Fig. 4-3 — Constant solar horizontal plane illuminance as a function of north latitude and time of year (time: local apparent noon ± 2 hours)

SPECIAL HANDLING

SPECIAL HANDLING

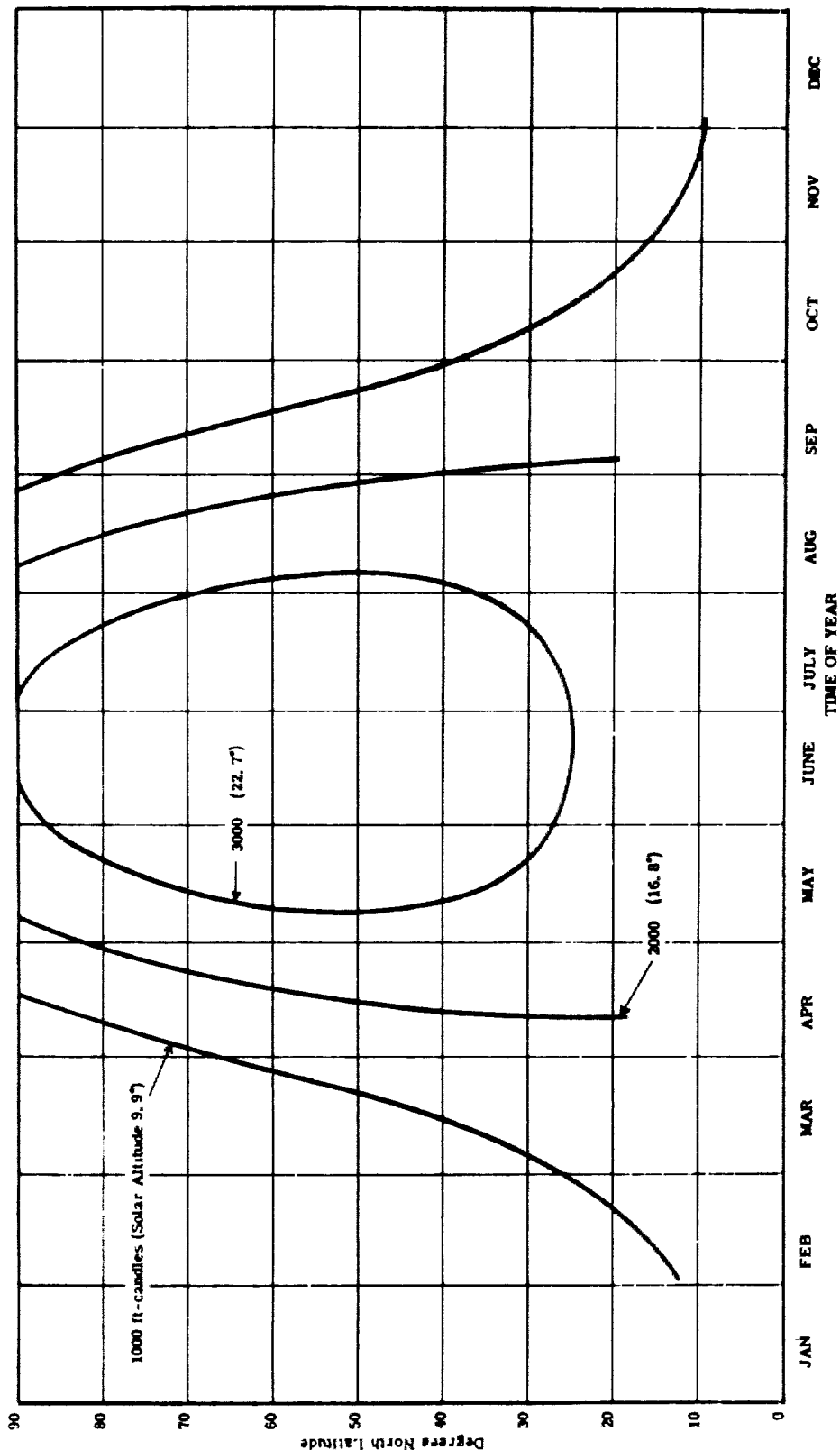

Fig. 4-4 — Constant solar horizontal plane illuminance as a function of north latitude and time of year (time: local apparent noon ± 5 hours)

SPECIAL HANDLING

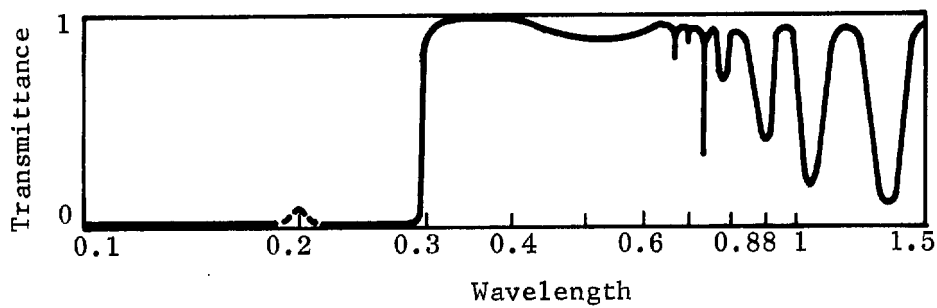

Fig. 4-5 — Reflected radiation useful for near visual UV and IR photography as restricted by atmospheric absorption.

SPECIAL HANDLING

SPECIAL HANDLING

called out at any time. Therefore, the resolution should be to the level required for detail analysis. The photographic target characteristics, discussed in Volume 2, Target Characteristics, show that a ground resolution of 1 to 2 feet will be sufficient for detail work on 95 percent of tactical targets. There are isolated targets, such as gun emplacements, which may require 3-inch resolution to determine detail such as caliber, and model. Therefore, a requirement for tactical photography should be a basic 1-foot ground resolution, with a 3 to 4-inch requirement on low altitude missions. It is well recognized that this level is not necessary for most analysis; however, it should be provided since there is no prior knowledge of what target area will require detail work.

4.1.2 Infrared

Analysis of the reconnaissance missions in terms of types of targets, mission time-altitude envelopes, and generic sensor capabilities has indicated that an infrared sensor can produce useful information both for visual interpretation and for automatic keying of certain types of targets. The first of these implies data having sufficient spatial resolution that the target size and shape may be recognized visually; the latter implies that an adequate variation and emitted energy occur to permit automatic threshold decisions without excessive interference from the background (anything not a target). Target studies presented in Volume 2, Target Characteristics, show that adequate imagery for visual interpretation is obtained with a ground resolution of 1 to 5 feet for the majority of missions. Sensitivity requirements for useful imagery of ambient temperature objects imply a noise equivalent temperature of the order of 0.25°C.

Automatic keying may be performed by selecting a field of view approximately matching the size of the target and automatically thresholding the output signal. Temperature variations averaged over the field of view should be at least 10°C for reliable keying.

Adequate imagery should be obtained for a total angular coverage of $\pm 60^\circ$ from the aircraft nadir. Keying data however may be useful from horizon to horizon. The high resolution coverage can provide both interpretive backup for the photographic data and keying to enable the air intelligence officer to select

SPECIAL HANDLING

areas for high detail priority analysis. Geometrical range variation reduces the interpretive utility of the infrared data at elevation angles much greater than 60° , but thermal variations may be observed which can be correlated with the SLR and ELINT data.

Because the infrared sensor produces imagery of the thermal radiation emitted from the scene, it is useful under both daytime and nighttime conditions. However, obscuration by clouds and inclement weather may prevent obtaining useful imagery.

4.1.3 High Resolution Radar

The present operational requirements for tactical reconnaissance include a high altitude mode for general reconnaissance and surveillance and a low altitude mode for survival or for detailed reconnaissance of preselected targets. There can be up to 20 preselected target areas for the low altitude mission. The mission duration will allow a nominal one half-hour of actual data gathering. The following tables give estimates of the aircraft performance for the high and low altitude missions:

High Altitude:

Aircraft Velocity	Mach 2 - 3
Altitude	40,000 - 80,000 feet
Maximum Radar Range	100 - 150 nautical miles (one side coverage)
	50 - 75 nautical miles (both side coverage)
Aircraft Velocity	Mach 0.8
Altitude	500 - 5000 feet

The raw data requirements are set by the mission duration, number of target areas, and type of target. A study of typical tactical targets has indicated that a radar sensor requires a resolution of 20 to 50 feet for the larger targets such as bridges, buildings, etc., while resolutions of down to a few feet are advantageous for smaller targets. The target radar characteristics can vary from strong, high contrast targets such as vehicles to low backscattering, low contrast targets such as roads and runways surrounded by grass fields.

SPECIAL HANDLING

SPECIAL HANDLING

4.1.4 Electronic Intelligence (ELINT)

Airborne ELINT systems can identify and locate sources of electromagnetic radiation within the "radio" spectrum by intercepting signals, analyzing their characteristics, and taking bearings on them. Although information concerning all radiating systems is of value, the most valuable information gathered by ELINT systems has been obtained from the interception and analysis of radar system emissions. Therefore, the majority of ELINT systems have concentrated on these signals. The radiations from radar emitters are usually characterized by repetitive pulse transmission of low duty cycle which are very amenable to detailed analysis by intercept equipment. Some of the radars, however, radiate a continuous-wave (CW) signal. The frequency range employed by radar systems extends from 30 megacycles to 30 gigacycles but the systems are usually clustered in small bands throughout the total range.

Target radiation characteristics which may be detected and measured by ELINT systems are discussed in detail in Volume 2, Target Characteristics. The referenced study discusses two signal environment models which were constructed to enable signal parameters and statistical data to be ascertained. One of the environments postulates a carrier task force operation in the Baltic Sea near the Soviet mainland during the years 1967-70. The second covers a task force operation near the country of North Vietnam in the year 1967. The Soviet environment is representative of a very dense signal environment, because of the presence of both strategic (permanently located) and tactical emitters. The Vietnam environment, on the other hand, is representative of a very light signal environment, since the radiations originate from a small population of fixed emitters located throughout the country. In both environments, the classes of equipments expected to be used are similar.

From the information presented in the target characteristics study, particularly the postulated signal environments, conclusions can be drawn concerning the characteristics of the raw signal data input to an ELINT system, which can be used to optimize the multisensor system. A tabulation of ELINT target identification and location characteristics points out that the primary usefulness of the ELINT sensor is activity detection, and that target complexes with associated radar and communication equipments can be identified and located. The keying

SPECIAL HANDLING

potential of the ELINT sensor pertaining to its use in keying other sensors in the system, is extremely high, especially where emitters are associated with desirable targets.

The target characteristics study mentioned above also contained plots of RF frequency versus pulse repetition frequency for Soviet radars over the complete frequency range of their operation. Figure 4-5(a) shows one of these plots, covering the frequency range of 2500 to 6000 megacycles and illustrates the significance of these parameters in identifying the functional type of an unknown emitter. In this figure, the abscissa coordinates represent emitter rf carrier frequencies, while the ordinates are emitter pulse repetition frequencies. Each small rectangle in the field of the plot represents the envelope of frequency versus prf known to exist for a particular functional class of radar equipments. In areas where rectangles overlap the possibility of ambiguous emitter identification exists. There is very little overlap of the frequency-prf envelopes, even though the frequency range between 2500 and 3500 megacycles (S-band) has the highest density of Soviet emitters in any portion of the spectrum. It may be observed from the figure that a large gap in the distribution of Soviet emitters appears in the region from about 3300 to 4900 megacycles. Such gaps are common in other portions of the spectrum.

It is apparent from the frequency versus prf plots that Soviet emitter functions, for the most part, are grouped in separate frequency-prf regions and can be successfully identified on the basis of this signal parameter set. Where difficulties exist because of the overlapping of the rf-prf envelopes, other signal parameters can be utilized to resolve the ambiguities.

The complete frequency spread of these radar sets occurs within the range of 70 megacycles to 10 gigacycles, and it is not expected to differ much in the next few years. Although no intercepts have been received from any operational emitters at frequencies above 10 gigacycles, the Soviets are doing development work in the K-band region, and there may be future traffic in this band. In addition, some traffic may appear within the present frequency gaps. Based on the information now available, the present frequency range of tactical ELINT systems, approximately 60 megacycles to 18 gigacycles, appears entirely adequate for an optimized system. The addition of a 30 to 60 megacycle receiver will extend the system into the VHF communication range, which may provide valuable intelligence.

SPECIAL HANDLING

4-11

SPECIAL HANDLING

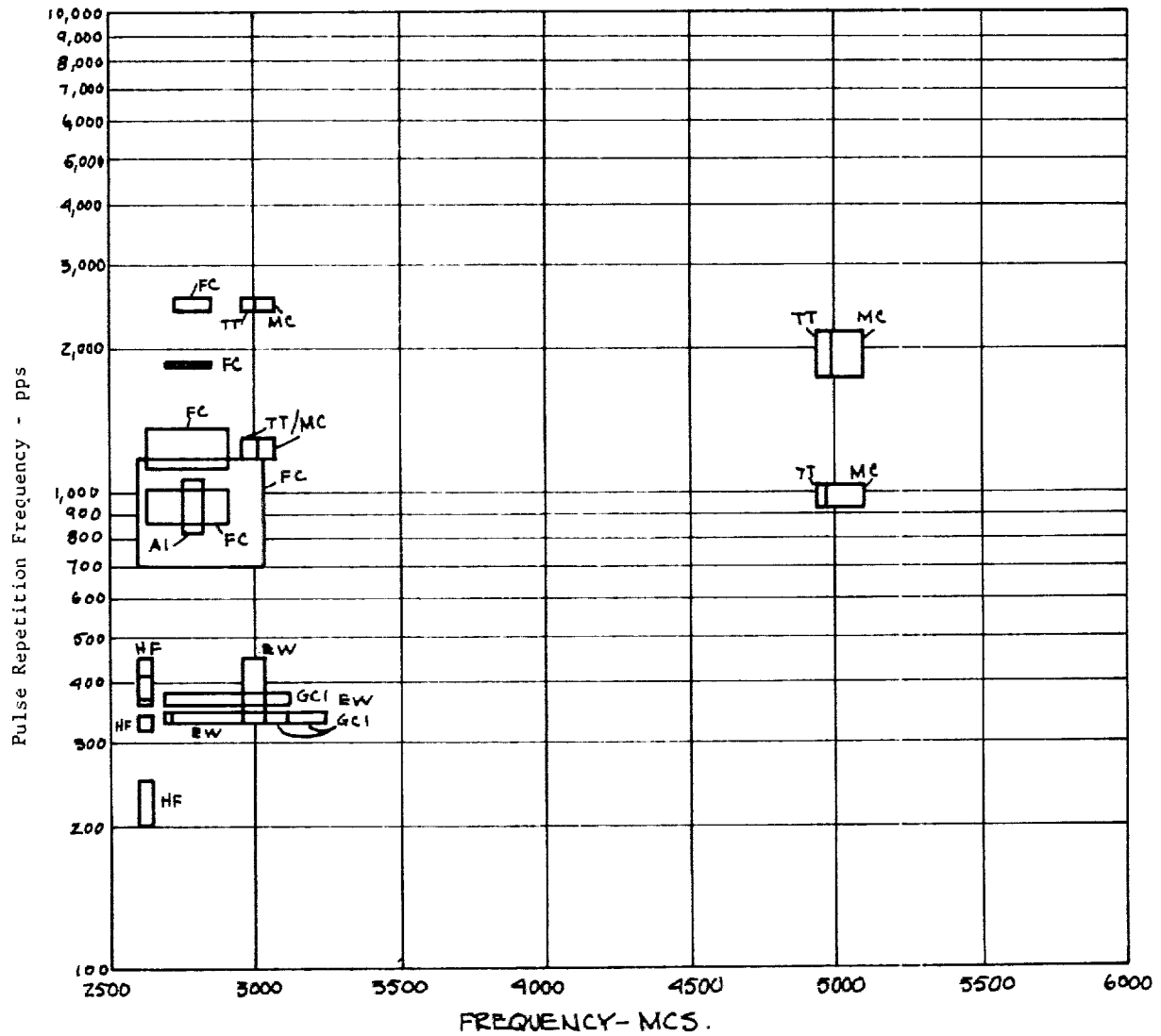

Fig. 4-5(a) — Plot of Soviet radar over 2500 to 6000 megacycle frequency range.

SPECIAL HANDLING

A characteristic of ELINT intercept data, which has a considerable bearing on the design of a system, is the signal traffic density. Traffic studies disclose that the density of just the tactical emitters associated with a Soviet Combined Arms Army (CAA) can be as high as 179 emitters radiating in an 8000 mile square area. This does not include the permanently located radar sets (strategic emitters), the communications systems, or airborne emitters. An area of 8000 square miles (nautical) is a circular area of approximately 50 nautical miles radius, and corresponds to the radio line-of-sight horizon for an aircraft flying at 1500 feet. For an aircraft at 500 feet, the radio horizon is approximately 30 nautical miles in radius, enveloping an area of approximately 3000 square miles around the aircraft. A total of 67 tactical radar emitters would be detectable within that area. At the higher altitudes, the signal traffic densities become proportionally higher. A peak density of 1000 emitters of all types across the entire frequency spectrum has been estimated for high altitude flights in dense areas.

There is a tremendous redundancy in the information content of intercepted radar pulse trains. Contrary to what might be expected, the high signal densities do not create a problem in the rate of data handling, even if real time analysis is desired. The problem is rather one of data sorting - separating the trains of interleaved pulses and correlating them with their emitters. A discussion of this problem, and its impact on the airborne and ground computer requirements is contained in Volume 4, Technology Survey. Real time analysis, as required by the optimized multisensor system, calls for a small general purpose computer to be located aboard the aircraft. By the insertion of a priori data on emitters of interest, such a computer can identify by function and locate up to 20 different kinds of emitters at a rate of 2 to 5 per second, thus satisfying the requirements of a tactical mission in the densest of environments.

Although the raw data input to the ELINT system in the form of emitter signal parameters is fairly well defined in a tactical situation, changes to existing emitters and new equipments can be introduced. The design of an ELINT system for an optimized multisensor system must take this into account, and provide a flexibility which can adapt to anticipated changes. Here is where the general purpose airborne computer can be highly valuable, because of its extreme versatility.

SPECIAL HANDLING

4-13

SPECIAL HANDLING

Simply by programming changes, the overall system response can be revised to keep up with changes in emitter characteristics or to fit almost any conceivable multi-sensor integration or mission plan. By proper programming, the ELINT system can accomplish such functions as alerting on specific emitter threats, identifying peculiar emitter combinations, searching for emitters in particular locations assigning priorities, preparing statistical plots, and so on.

Countermeasure activity will be attempted to prevent the identification and location of battlefield emitters by ELINT systems. Two standard techniques are rapid frequency shifts in a random manner (frequency-jump radars) and jittered pulse repetition frequency. Frequency-jump radars employing rotating vane magnets are relatively simple to implement, and it is expected that their use will increase. Their greatest effectiveness is against a slow-scanning receiver because of the time required to accumulate enough samples over a number of scans to make a positive identification. Once again, it is the tremendous redundancy in pulses which makes the solution possible. Contemplated improvements in wide-open and rapid-scan receivers are expected to minimize the effects of this subterfuge. Pulse jitter, likewise, only serves to increase the processing time. The location of an emitter, determined by monopulse angular fixes, is not particularly affected by most countermeasure techniques.

A summary of the raw data input requirements for an ELINT subsystem in an optimized multisensor reconnaissance system can now be made. These requirements are imposed on the system by the nature of the radiated signals and their expected densities in a battlefield environment. The requirements are given in Table 4-1. These requirements for an optimum multisensor system are no different from those levied against today's ELINT systems, and which presently-programmed ELINT systems are capable of meeting.

SPECIAL HANDLING

Table 4-1. ELINT Input Data Requirements

Frequency Range	60 mcs - 18 gcs (30 mcs - 60 mcs optional)
PRF Range	100 pps - 5000 pps
Pulse Width	0.1 μ sec - 29 μ sec
Pulse Amplitude	30db in 4db steps
Geographical Coverage <	To radio horizon forward and sides
Pulse Density	10 ⁶ pulses per second max
Within-pulse modulation	Detectable
Modulation Characteristics (non-pulse)	Type Detectable

SPECIAL HANDLING

SPECIAL HANDLING

4.2 SENSOR OPERATING CHARACTERISTICS

For a reconnaissance aircraft to collect the necessary data, either of two major installations schemes can be used. First, the sensor complement can be configured to collect all the information from high and low altitudes with no modular equipment changes for sortie parameter modification. Second, the sensor complement can be configured in a modular fashion, and high and low altitude components can be exchanged as required by the sortie parameters.

The evaluation of these basic systems has included consideration of maintenance, mission readiness, and versatility. It has been concluded that the sensors should be permanently carried for both altitude envelopes with provision for special purpose systems such as photographic stand-off cameras or foliage penetration radar as modular add-on units. The reasons for this conclusion are:

1. A quick response to sortie change on the carrier is required.
2. Sortie requirements may dictate both high and low coverage.
3. A modular maintenance/replacement system can be utilized to advantage.
4. The adaptive characteristic of the well-equipped aircraft will enhance the ability for mid-sortie changes in situations of opportunity.
5. There is no major requirement for different systems except for the photographic sensor.

The overriding reason is the simplicity and lack of logistic problems in meeting the need for flexibility under time pressure. The launch/retrieve cycle of a tactical mission dictates almost instant readiness, on the decision of the air intelligence officer, of the aircraft for either high or low altitude operation.

4.2.1 Photographic Sensors

It has been developed that the photographic sensors should collect image data on normally pre-assigned target areas to a ground resolution level of 1 foot or less. As shown in Fig. 4-6, most sorties will likely be flown at either low altitude (500 to 1000 feet) or high altitude (30,000 to 60,000 feet) for reasons of aircraft survival. It is recognized that in a non-combative situation

SPECIAL HANDLING

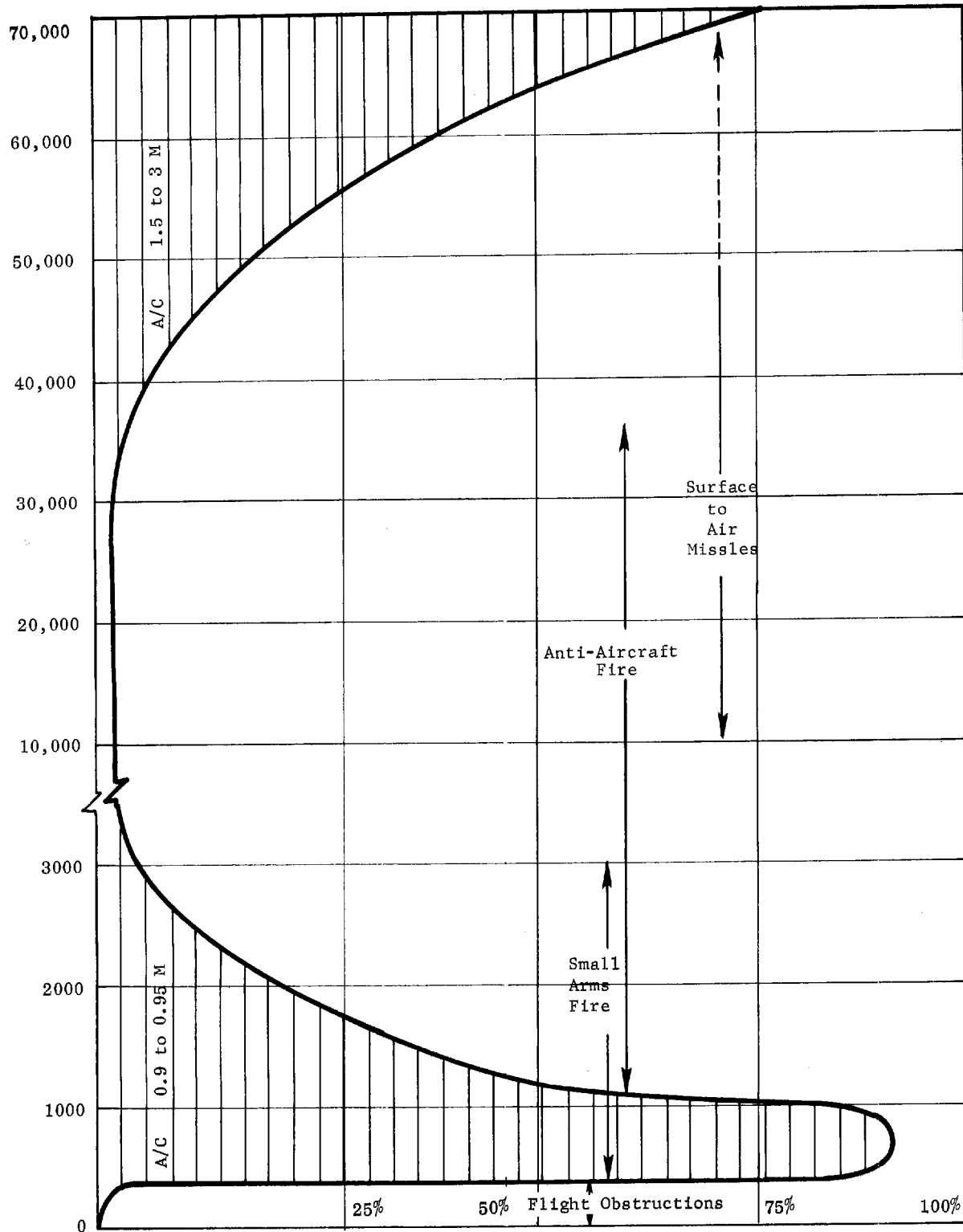

Fig. 4-6 — Typical survivability versus operating altitudes for high performance aircraft tactical reconnaissance.

SPECIAL HANDLING

SPECIAL HANDLING

the altitude can be selected freely, where an altitude on 3000 to 5000 feet and 30,000 feet would be representative of the low and high altitude regime, respectively.

Each region of altitude provides collection of specialized data. The high altitude region will be used for large area, basic cover, with specialized stand-off requirements on occasion. The low altitude region will be used to acquire detail cover, and perspective cover when using oblique sensors. In tactical operations, the oblique views, when used with vertical views for geographical orientation, are highly valuable. Normally, low oblique angles will not provide useful information from high altitude for lack of resolution. The long range stand-off camera, however, is a specialized low oblique camera, useful for long range work from high altitude; it is limited in coverage, and is very sensitive to orientation problems, and cannot be classed as a tactical device except as a special tool for covert observations.

4.2.1.1 Photo Sensor Requirements

To attain the required ground resolution, established as less than 1 foot, and to provide useful information in the views required, the following low altitude cameras are considered necessary:

1. A short focal length, wide field frame/strip camera - vertical.
2. A moderate focal length, 180-degree panoramic camera - vertical.
3. A moderate focal length frame camera - side oblique.
4. A wide angle, moderate focal length frame or panoramic camera - forward oblique.

The capability of these cameras to provide basic information will be discussed in paragraph 4.2.2. In addition, the versatility of the photographic system can be increased by adding the following sensors:

1. A short focal length vertical strip/frame for additive color (identical coverage).
2. A short focal length vertical strip/frame for camouflage detection (identical coverage - near visual IR).

SPECIAL HANDLING

The theory of additive color and camouflage detection with spectral separated, identical coverage black and white photography is discussed in Volume 3, System Characteristics. Briefly, the concept is that the spectrally separated identical images can be superimposed in two or three color projections to provide a high resolution real color or camouflage detection color image. This is similar to the familiar Technicolor process.

Color for interpretation or camouflage detection is extremely valuable. In black and white photography, detail is lost since the conventional grey tones are not keyed as to their real color content. However, there is a penalty of redundant equipment, which classes this system as optional for a basic sensor package. The use of color films has been discussed in Volume 3, System Characteristics, and while a possibility, it is not felt that the prime record can safely be a color image, thus sensor redundancy for color is necessary, and it is felt that the higher resolution additive color system is superior from an operational standpoint.

The usefulness of stereo coverage, especially in the vertical imagery, is also extremely valuable. The frame camera, and the panoramic camera, operating in the vertical can provide stereo for interpretive viewing by simply allowing greater than 50 percent overlap along the flight path from frame to frame. Provision should be made at the viewing station to allow stereo viewing from a single record when it is required. The option of carrying a redundant record for the sole purpose of providing stereo is considered an excessive penalty of the operational efficiency of the total system.

The need for a high altitude capability, concurrent with a low altitude system, requires more sophisticated cameras in order to achieve the one foot ground resolution. The equipment suggested for the high altitude mode is as follows:

1. A frame or panoramic camera to provide a large area, distortionless, basic photo map. A 120-degree maximum field angle is required, with a moderate focal length lens resolving 6 to 8 feet from 60,000 feet altitude.
2. A panoramic camera, with a long focal length to provide a field angle of 90 degrees with 1 foot ground resolution from 60,000 feet.

SPECIAL HANDLING

SPECIAL HANDLING

Both high altitude cameras should have 55 percent overlap for stereo coverage. The option of 10 percent overlap should be available to increase coverage on long missions at the loss of stereo.

Optional high altitude equipment considered for the multisensor mission is a camera for special long range oblique photography. Since the stand-off requirement is a rare one, this camera should be considered as an exterior store system, probably a self-contained pod unit for ease of use. In this way the very long focal length system needed for 60 to 100 nautical miles stand-off will not occupy needed aircraft space. The use of frequency is expected to be low for this item, and it will be a physically large optical system, so that the pod concept has many advantages.

4.2.1.2 Typical Camera Systems

The characteristics of several camera systems which fulfill the general requirements for coverage and resolution outlined previously is presented here for evaluation of their parameters.

An attempt has been made in evaluating the camera systems to standardize formats. This has been carried only to the point where no penalty is incurred by way of increased system complexity, weight, or volume. The cameras therefore utilize 5 inch and 70 millimeter film only, and the selection is often on the basis of existing camera equipment.

Low Altitude Photo Systems — The following cameras fulfill the requirements for photographic operation at 500 feet altitude and a ground speed of 1000 feet per second, these conditions being taken as standard.

1. Frame/Strip Camera — A frame camera, similar to the KA-51, mounting a 44 millimeter f/5.6 Wild Super Avioigon lens could be used for the vertical, wide angle coverage. The camera should have a focal plane shutter, modified to convert the operating mode from frame to strip, by stationing an adjustable slit across the center of the format. The normal IMC drive system, operating continuously would permit use of the frame camera as a strip camera (see Fig. 4-7(a)). The camera would normally be operated as a frame camera, with a 60 percent overlap for stereo (see Fig. 4-7(b)). In this mode a frame cycle time of 1/2 second

SPECIAL HANDLING

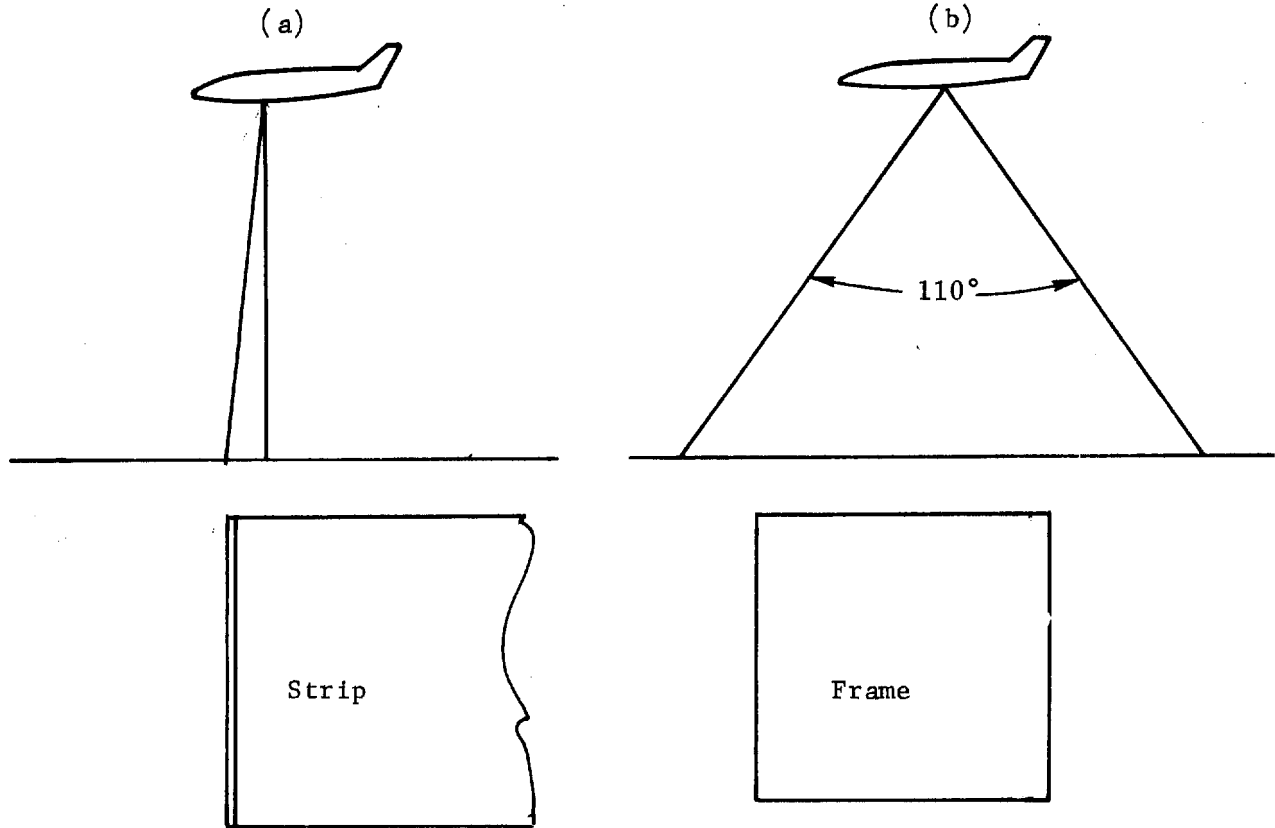

Typical Ground Coverage

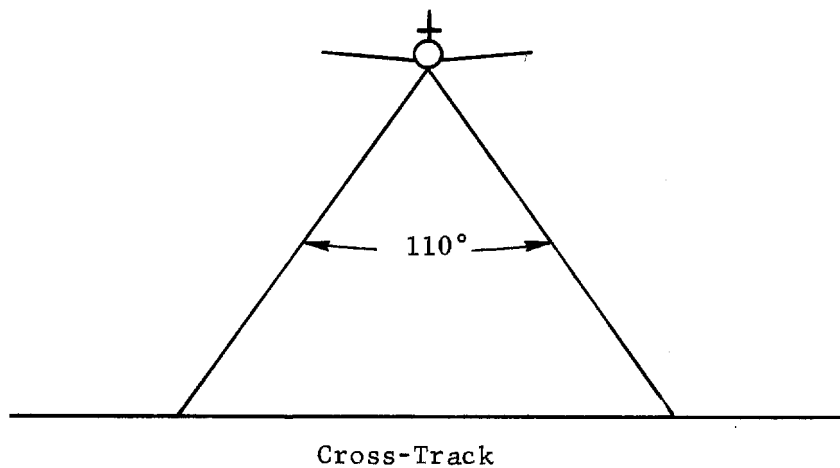

Fig. 4-7 — Frame/strip camera - 44 mm EFL, 5" Sq. format (vertical)
(1 permanent) (2 optional)

SPECIAL HANDLING

SPECIAL HANDLING

is required for the worst mission profile considered. The resolution performance of this system can be described as follows. The lens/film static resolution of the Super Avlogon lens has been measured at 160 lines per millimeter. Degrading that performance to 50 lines per millimeter for dynamic use on Plus-X aerial film (4401), calculations indicate that with an illumination of 200 foot lamberts, an exposure time of 1 millisecond (1/1000 second), and at 2:1 contrast, a ground resolution of 3 inches can be obtained. This camera can be hard mounted and provide ground resolution of less than one foot from altitudes of up to 2000 feet.

For this reason, the value of a wide field angle camera with good resolution cannot be overlooked. The 55-degree slant range at the edge of the field is at about the maximum angle for meaningful photography. Beyond this point, perspective problems, scaling, and shadowing effect begin to seriously degrade the image quality. At low altitude, the effect of increased atmospheric path length is not as important as for high altitude systems.

The wide angle coverage of the vertical camera is designed to correspond with the cross-track coverage of the vertical IR sensor. In this way the records from the two sensors will be easily compared. It is felt that the wide field angle is a superior solution to the coverage problem, as compared with any kind of selective or multiplexed coverage, because of its simplicity, and the knowledge that no important, unknown target will be missed.

2. Vertical Panoramic Camera — A panoramic camera, similar to the Perkin-Elmer or Fairchild rotating prism pan, is suggested to complement the cross-track coverage of the frame camera. The slightly longer focal length of 3 inches will provide better theoretical resolution. The primary purpose of this camera, which can cover a 180-degree cross-track field angle with 40 degrees forward coverage (Fig. 4-8), will be to provide photographic imagery of the marginal areas beyond the frame camera limits. This is important to the system concept in order that the areas seen by the IR hot spot system, the SLR, and the ELINT will have photo coverage. It is recognized that the coverage will not be of primary use beyond the 60 degree elevation angle; however, target indications from one or more of the other sensors can be compared to imagery and some

SPECIAL HANDLING

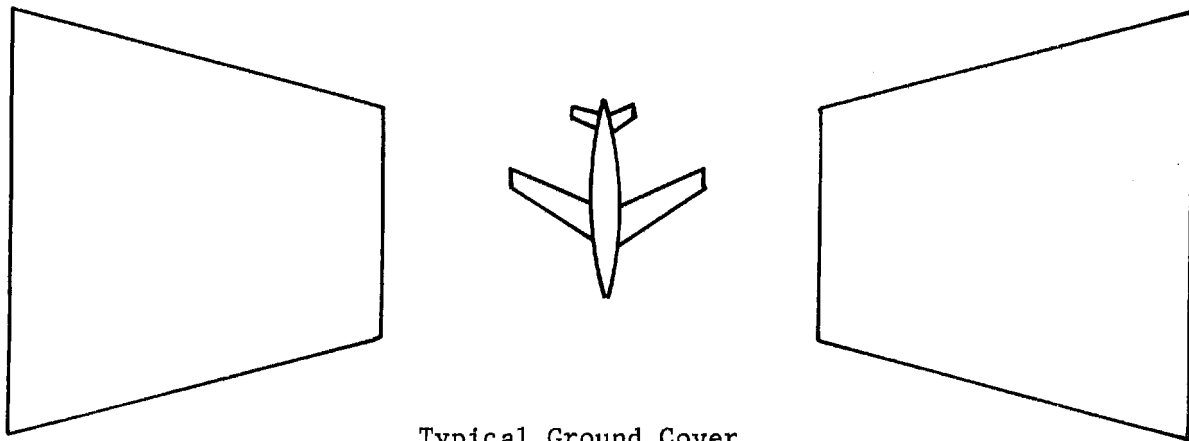
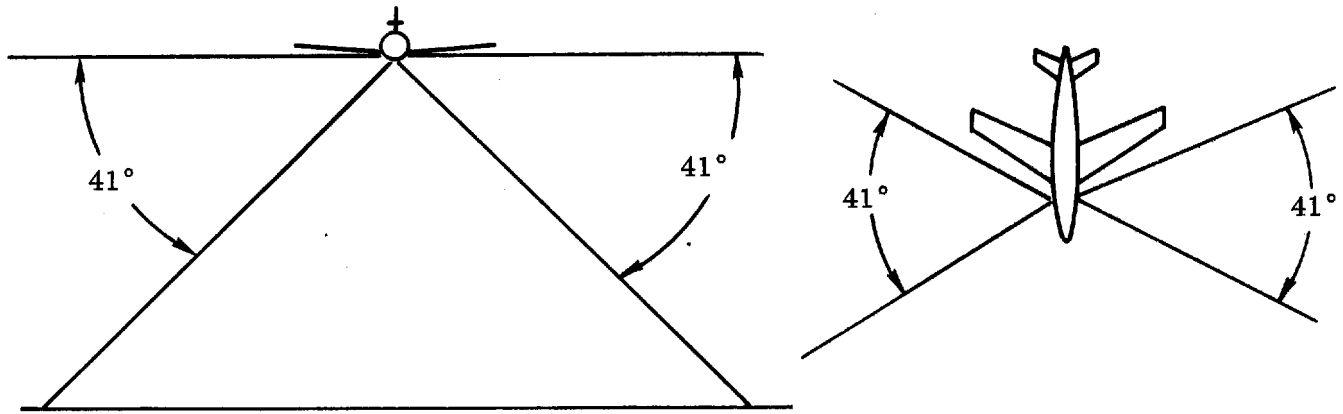

Typical Ground Cover

Fig. 4-8 — Frame camera - 3-6" EFL, 5" Sq. format (side oblique).

SPECIAL HANDLING

SPECIAL HANDLING

valuable intelligence may well result. The system ground resolution should be on the order of 3 inches at nadir from a hard mounted camera operated under the same conditions as the frame camera previously discussed. The camera will use a 70 millimeter format, and have a cycle rate of 6 to 8 frames per second at the standard altitude and speed selected.

3. Frame Cameras - Side Oblique — Frame cameras mounted in the side oblique position to form a fan array with the vertical provide a valuable tool for the interpreter. A camera similar to the KA-51 with a 6-inch f/2.8 lens, mounted at a 20-degree depression angle will provide coverage to the horizon, and will overlap the vertical field by 10 degrees (lens field angle of 41 degrees - see Fig. 4-9). This coverage is redundant to the pan camera and some justification of the separate functions is required. The pan camera provides an unrectified, but complete swath from horizon to horizon for direct comparison with other sensor records which are keyed along the flight path. The side oblique frames will be of different scale from the vertical, and to determine keyed locations along the flight path may require some scale adjustment. The oblique record could be used, however, to do comparisons with other sensors by properly setting up the viewing system. The primary use of the side oblique is for beach and road surveys and similar operations where perspective photographs are desired along a long path, most easily covered by parallel flight.

The resolution capability of the 6-inch system in this side oblique camera is about 4 to 6 inches under standard conditions on axis (20-degree depression from horizon).

4. Panoramic Camera - Constant Scale-Forward Oblique — A panoramic camera has been selected to illustrate the required coverage for the forward oblique. A normal pan system with its scale changes and scan induced degradations would produce a distorted view from this position. The use of a constant scale pan camera, in which the effective focal length varies with the scan, produces a nearly distortionless wide angle frame. This is accomplished using a zoom lens and a stationary film plane. The wide angle coverage will be quite important, since it allows a valuable low level interpretation which nearly represents the

SPECIAL HANDLING

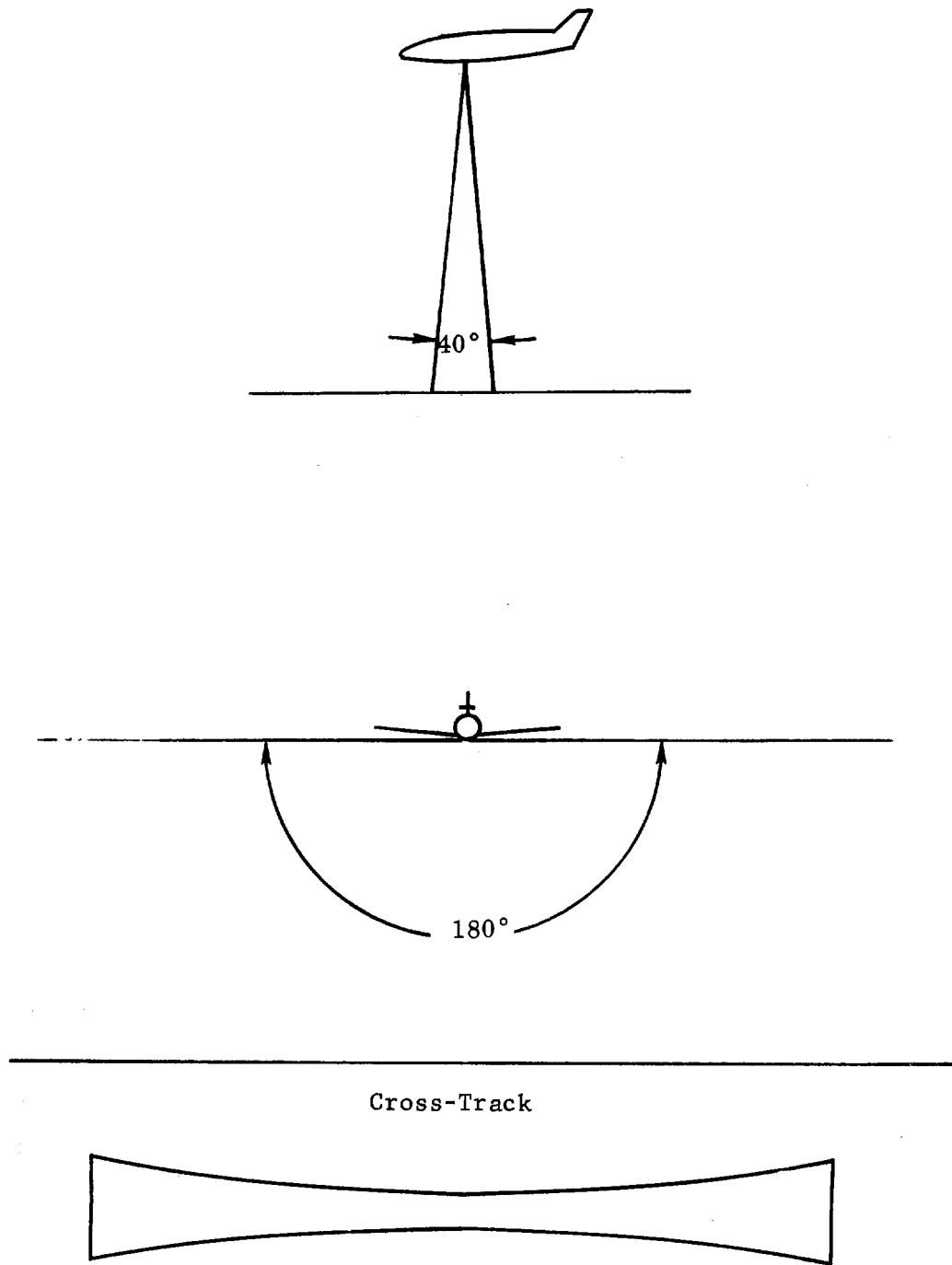

Fig. 4-9 — Panoramic camera - 3" EFL, 70 mm or 5" format (vertical).

SPECIAL HANDLING

SPECIAL HANDLING

field of view of the pilot/observer. The perspective advantage, and cover penetration available in this view are often more valuable in gaining intelligence than the vertical imagery. When combined, the pair offer tremendous interpretive possibilities. Therefore, the field of view (120 degrees) has been selected to give as wide, identical ground coverage as possible.

The lens system selected for this camera is a compromise between resolution and ground coverage. Because the IMC varies across the format due to the varying range in the oblique position, a determination has been made to provide only an average IMC correction for the axial position. Therefore the resolution over the format will be limited by image blur caused by the aircraft speed. Since worse resolution will be limited to anywhere from 8 to 12 inches, a 2 to 4-inch zoom lens system has been selected to maximize areal coverage.

The use of a panoramic system also carries the advantage of a lower f number for the system which, in turn, allows faster exposure and less image blur from motion. The lens selected in a 2 to 4-inch, f/3.5 zoom system which will image on a 70 millimeter format. Thus the field of view (see Fig. 4-10) is 50 degrees forward and 120 degrees cross-track with no resolution fall off at the edge of the format. As noted, the resolution will vary across the format (the forward aircraft direction) from 6 to 12 inches depending on the IMC error at the format point.

5. Optional Frame Cameras - Vertical — It has been stated that spectrally separated identical coverage can yield highly valuable intelligence. Using this system for color and camouflage detection systems now appears to have great interpretive value. Figures 4-11 through 4-14 show the comparison between black and white, color film, and spectrally reconstituted color and camouflage detection. The resolution and information content can readily be seen. The black and white photograph which is shown is the normal aerial filtered image, and the reconstituted images are made by adding a near visual IR and a blue-green image. Thus the original interpretation can be made on the black and white, with detail, comparative work utilizing the color or camouflage detection views when required. It is strongly suggested that the three camera array in the wide angle vertical is a very valuable innovation for tactical reconnaissance.

SPECIAL HANDLING

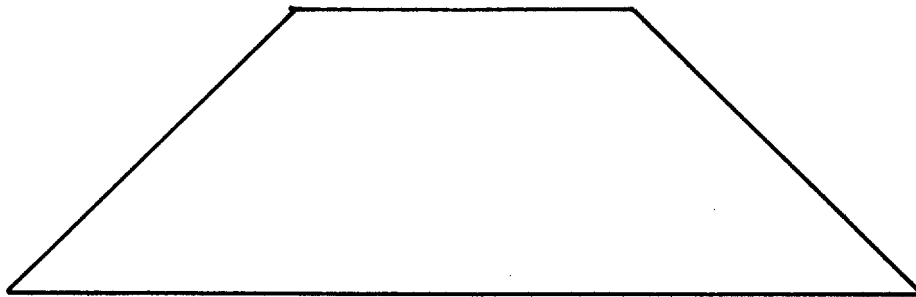
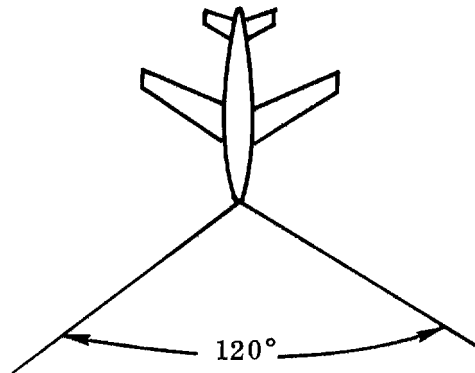
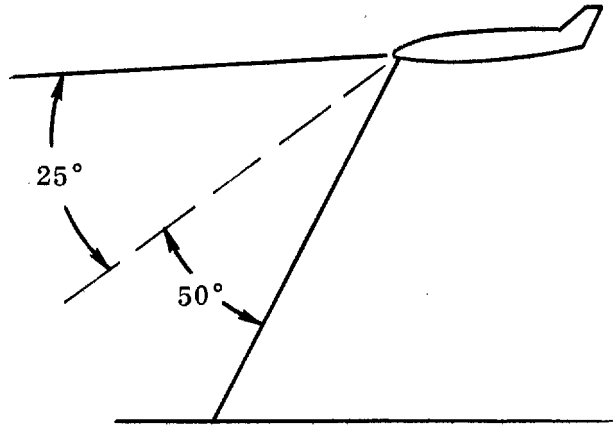

Fig. 4-10 — Frame or panoramic - constant scale pan
2" - 4" EFL, 70 mm format (forward oblique).

SPECIAL HANDLING

SPECIAL HANDLING

SPECIAL HANDLING



Fig. 4-... Urban Area - Black and white print.



Fig. 4-12 — Urban Area - SO-121 color film.



Fig. 4-13 — Urban Area - Additive color from black and white negatives.

SPECIAL HANDLING

This can be demonstrated by observing the features which are not noticeable on the black and white scene, Fig. 4-15, or the color scene (S0-121) Fig. 4-16 which become immediately evident in camouflage, Fig. 4-17. As has been demonstrated, color film processing does not currently lend itself to time pressured operations, conversely the black and white images in the spectral separation system are easily handled, even to inflight processing.

The reconstitution problem can be handled in viewing equipment which is currently available.

High Altitude Photo Sensors — The following camera systems are suggested to fulfill the requirements for photographic operations at up to 60,000 feet altitude and ground speeds of up to 2000 feet per second, these conditions being taken as illustrative standard.

1. Panoramic Camera - Constant Scale-Vertical — The camera requirements for high altitude fall into two basic categories; the need for properly scaled, large-area mapping imagery and the need for high ground resolution (1 foot or better). The constant scale panoramic camera with a 6 to 12-inch focal length lens system which can cover a 120-degree cross-track area is suggested to yield the mapping imagery which is required. Cross-track coverage can be increased to 140° if required. Wide angle frame cameras, split vertical cameras, or fan arrays could be used, but impose a weight and complexity problem. The constant scale pan camera can use a fast lens (f/3.5) and normal IMC features and record imagery sometimes unavailable to wide angle lens systems due to light conditions. The vertical pan camera will have a ground resolution of 6 to 8 feet, which will provide good reference mapping capability. The field of view of this camera is illustrated in Fig. 4-18 and is 25 degrees along the flight path and has 120-degree cross-track coverage. The camera should utilize 70 millimeter film to minimize volume and weight and, under the standard conditions, it will have a 12 cycle per minute rate with 55 percent overlap for stereo viewing if required.

The cycle times and ground resolution for this camera indicate that it will be an excellent mid-altitude camera which can operate satisfactorily and with constantly improving performance at altitudes down to 5000 feet.



Fig. 4-14 — Urban Area - Additive color camouflage detection from black and white negatives.

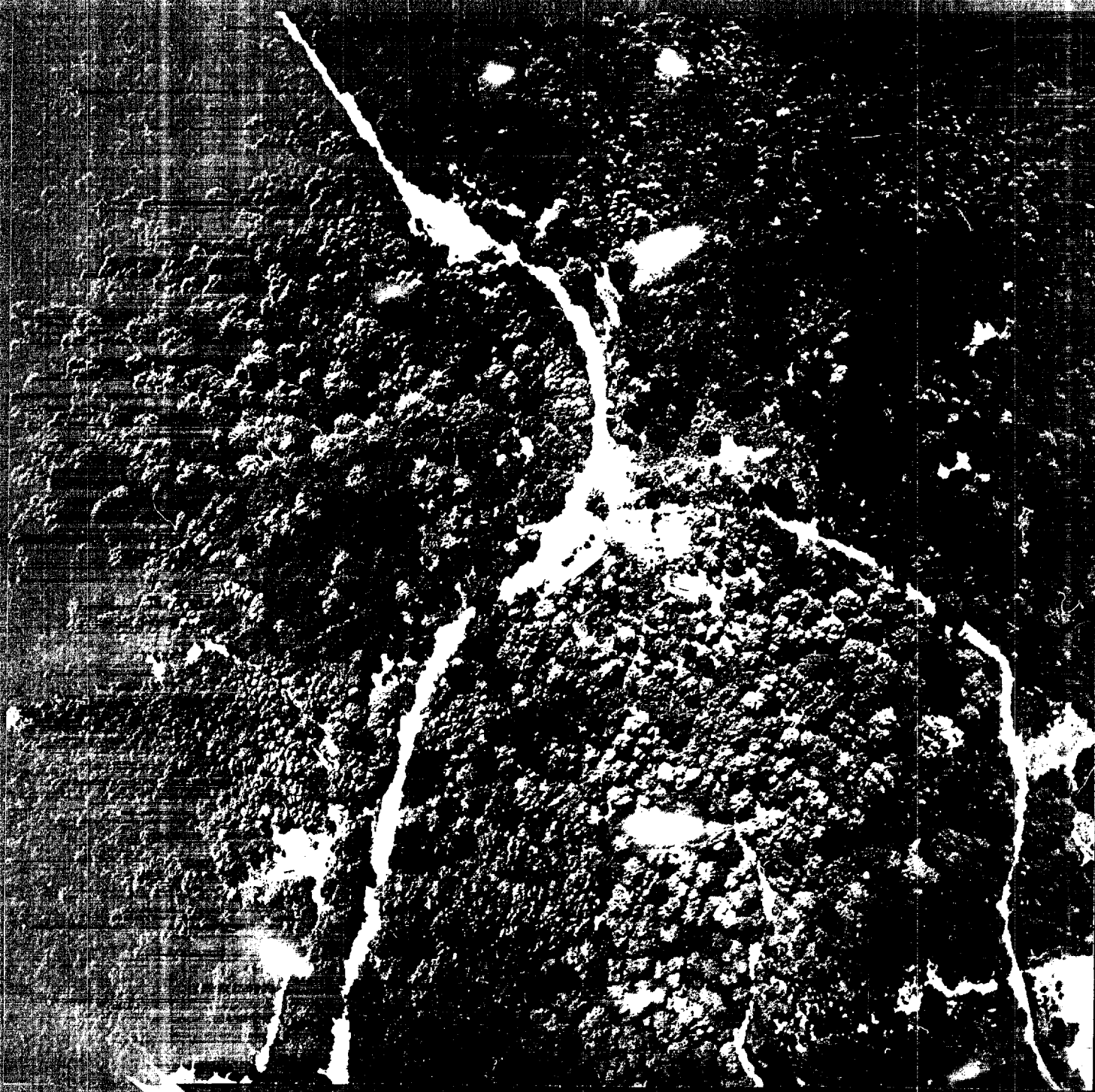

Fig. 4-15 — Forest Area - Black and white print.



Fig. 4-16 — Forest Area - S0-121 color film.

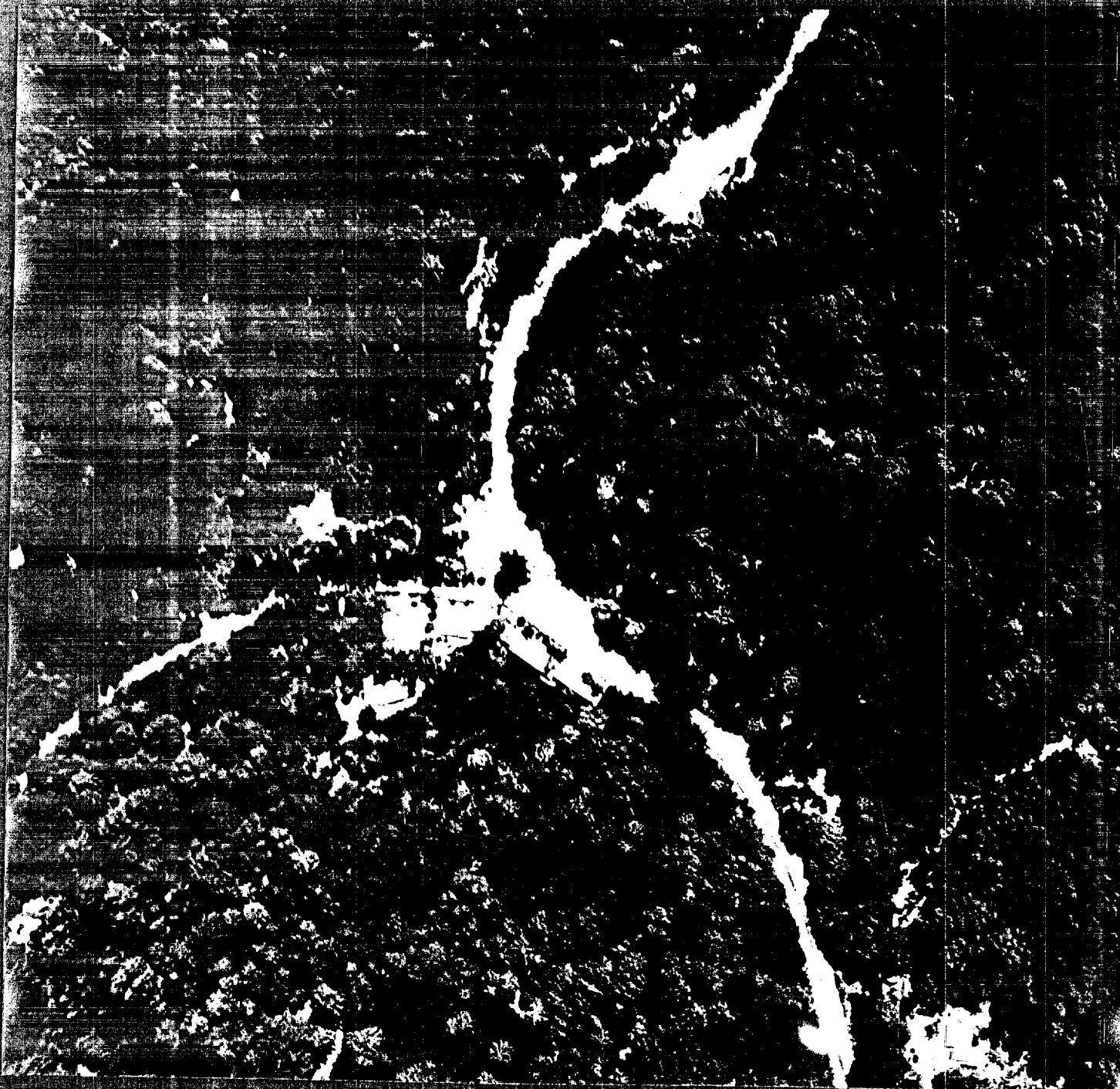

Fig. 4-17 — Forest Area - Camouflage detection film.

7-35a

SPECIAL HANDLING

SPECIAL HANDLING

SPECIAL HANDLING

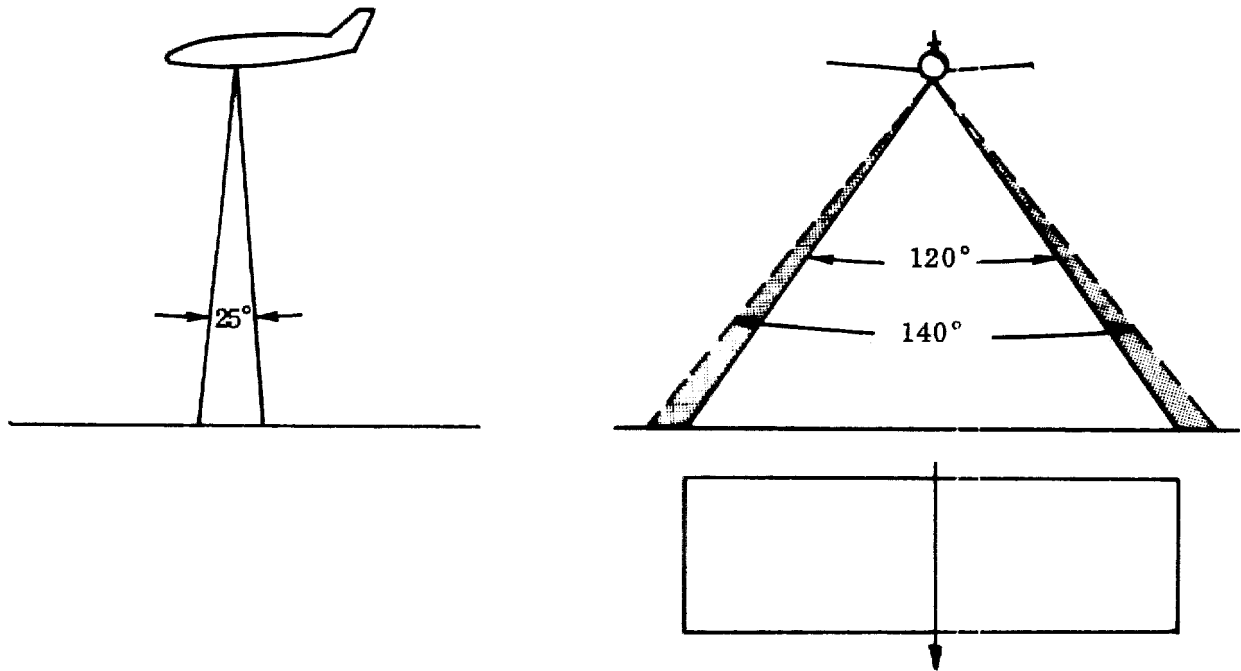

Fig. 4-18 — Constant scale pan - 6-12" EFL, 70 mm format vertical - (high-med altitude).

SPECIAL HANDLING

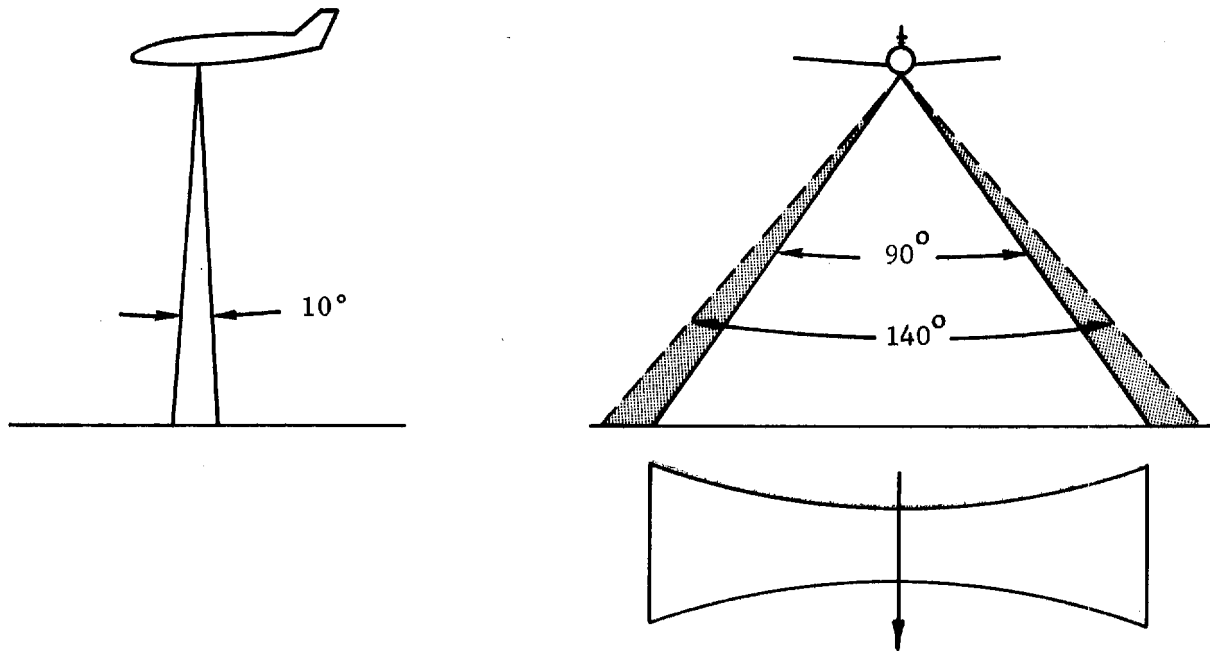

Fig. 4-19 — Panoramic - 24" EFL, 5" format, vertical (high alt.)

SPECIAL HANDLING

SPECIAL HANDLING

2. Panoramic Camera - Vertical — The major camera installation suggested for the photographic equipment complement is a vertical standard panoramic camera, similar in operation to the HYAC camera, that is, with stationary film and a high resolution lens rotated about its nodal point to sweep the image.

A lens similar to the f/3.5 Petzval with a lens-film resolution of 150 to 200 lines per millimeter is required to attain the 1 foot ground resolution which is possible under good atmospheric conditions.

With a 500 foot-lambert average light level and a 2:1 contrast using a yellow-orange filter to reduce haze effects, a ground resolution of less than 1 foot can be expected from such a lens. The exposure time of 1/500 second and 3 percent error in IMC dictate the film resolution on SO206 would be about 130 lines per millimeter, which from 60,000 feet is the calculated resolution. At this resolution level, the performance of any camera system is at the mercy of the atmospheric conditions between the lens and the terrain. The contrast level is reduced to 2:1 or 1.6:1 and turbulence cell size becomes important. On an operational basis, the camera system suggested will provide the calculated resolution. From 60,000 feet, the field of view should be a 90 degrees cross-track and 10 degrees along the flight path (see Fig. 4-19) using a 24-inch f/3.5 lens on 5-inch film. Thus, a single frame will be 36 inches long and cover a 20-nautical mile swath. With 55 percent overlap, the cycle time will be about 2 1/2 seconds, becoming faster as altitude decreases. If operational requirements dictate a very wide swath, the angular coverage can be increased to 140-150°, and even to 180°. Resolution, degradation, and distortion will be a problem at the higher elevation angles however. The imagery produced by this camera will require rectification if it is to be used for mosaic purposes. However, for tactical intelligence purposes, there should be no need for rectification, if a proper viewing grid can be provided for target location purposes.

3. Optional Stand-Off Camera — The mission requirements of the stand-off sortie are not established sufficiently in the analysis made for this system concept to allow a particular selection. In general, the long focal length lens system useful for this mission have relatively small fields of view, ranging from 5 degrees down to 1 degree or less. It is suggested that systems with a 60 to 70-inch focal length can typically resolve 2 to 3 feet at distance of 500,000 feet (80 nautical miles). A fast f/4 lens with a 5-inch format to yield

SPECIAL HANDLING

4-37

SPECIAL HANDLING

a 4-degree field, mounted axially with sophisticated tracking mirrors and motion stabilization, would mount nicely as an exterior pod store. In this way the attachments for the equipment and the control systems could be permanently assembled, without requiring fuselage space, and relieving the dead weight problem on normal missions.

The stand-off camera then, which can be required on some task force assignments, is suggested as a pod-mounted external system, with permanently installed control systems for quick add-on.

4.2.1.3 Conclusions

The photographic sensors have been selected to cover the useful fields of view in their entirety. The concept of "cueing" or directing the photographic sensor or any other system from another has been discarded because of the lack of image or information continuity which this concept imposes. Each photographic sensor will contain a standard data block system, and a key data system which will be described in Section 4.7. The sensor complement has been reduced to maintain all the necessary data in as few records as possible to reduce the material handling problem. No attempt will be made to realize real time information from any of the photo systems since other sensors on the aircraft are better adapted to this function.

4.2.2 Infrared Sensors

In order to obtain the data described in Volume 2, Target Characteristics, an infrared sensor must have angular resolution of the order of 0.1 milliradians for the high altitude envelope and 1 milliradian for the low altitude envelope. The required resolution can be obtained by a sensor having an entrance aperture diameter of 8 to 10 inches. It will be necessary to employ an array of detectors in the focal plane to achieve the required temperature sensitivity and information rate. Hence, the field of view may be selected electronically to correspond to the mission profile. It will be necessary to provide variable scan rates for the optical scanner. This type of sensor will be capable of gathering information at the maximum required rate on a continuous basis,

SPECIAL HANDLING

4-39

SPECIAL HANDLING

limited only to the data storage and/or transmission capability. No interaction with any other sensor is required during data gathering, although keying information from the other sensors will appear on the infrared sensor record. In addition, time and navigational data will be recorded.

Keying data from the infrared sensor will be quantized to provide the coordinates on the image display plus thermal radiation amplitude. This will form a digital word containing approximately 18 bits. It will be recorded on the infrared record and made available to the operator display and other sensor records.

4.2.2.1 Optimized Infrared System (Example Configuration)

Two types of infrared sensors are suggested for inclusion in the optimized multisensor system. One of these is a forward looking device similar to a unit presently being built by Texas Instruments Company. This unit is particularly useful for low altitude missions and as a real time navigational aid. Its resolution is limited to approximately 1 milliradian.

The panoramic scanner is best mounted below the aircraft in an aerodynamic designed housing which prevents direct contact of ram air upon the optical window. This type of mounting will also permit a minimum of 120 degree scan angle with extension to 170 degrees if keying data near the horizon is desired to correlate with that from the SLR. This type of mount is illustrated in Fig. 4-19(a).

The second sensor is of the panoramic type designed for both high altitude and low altitude missions. It is capable of 0.125 milliradians and is provided with a real time display.

The forward looking infrared sensor scans a field 10 degrees in elevation by 45 degrees in azimuth with a spatial resolution of approximately 1 milliradian. The scan is two-dimensional at rates such that six complete frames are produced per second. The elevation angle of the center of the frame may be altered for use during a particular mission.

The signals produced by this scanner may be recorded directly on film or processed as described in Section 4.2.2.3.

SPECIAL HANDLING

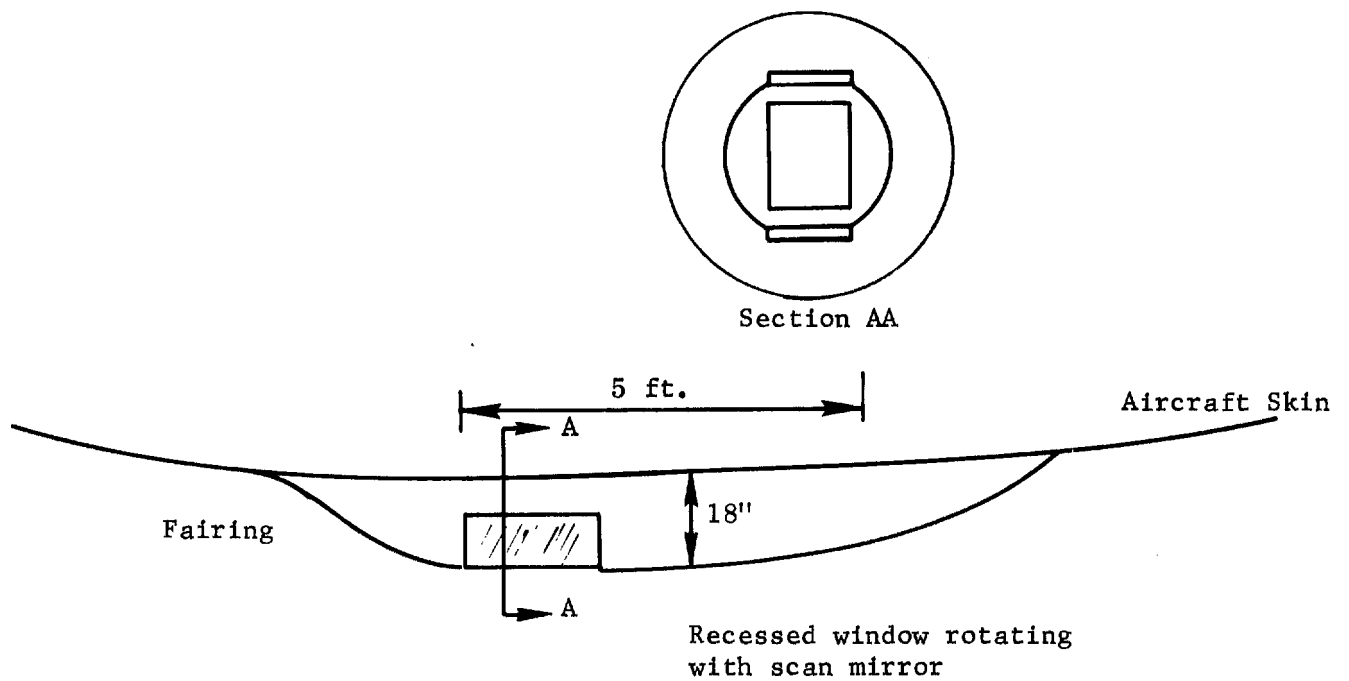

Fig. 4-19(a) — Example mounting for IR panoramic sensor.

SPECIAL HANDLING

SPECIAL HANDLING

Infrared Scanner Configuration — The infrared scanner consists of several basic elements. Incoming infrared energy from the scene is directed into a primary optical system by a scanning 45-degree mirror which directs the field of view along a path perpendicular to the aircraft motion. A secondary mirror directs the energy upon an array of mercury doped germanium detectors whose spectral response is determined by cooled filters. These detectors are cooled to 30°K by a closed cycle heat engine. The outputs of the detector array are preamplified by matching electronics adjacent to the detector to the detector dewar. The entire assembly is approximately 14 inches in diameter and 60 inches long. A summary of its pertinent parameters is given in Table 4-2.

1. Optical Configuration — A single configuration which is useful for both high altitude and low altitude missions is illustrated in Fig. 4-20. A 10-inch diameter collecting beam is directed by a rotating 45-degree mirror. This mirror rotates continuously in one direction, but is switched 90 degrees twice each revolution. This provides a highly efficient scan. A 80-inch f/8 Cassegrain primary optical system forms an image upon a detector array. Two arrays of detectors are provided; one having an elemental field of view of 1.25×10^{-4} radians and the other having an elemental field of view of 0.5 milliradians. The first array to be used during a particular mission is selected by a 45-degree mirror just behind the primary.

2. Detector Configuration — Two separate arrays of mercury doped germanium are located in a single dewar. One array consists of 96 elements, each 0.01 by 0.01 inch. The elements are arranged in a single line with approximately 0.002 inch spacing between elements. The technique for fabricating arrays of this nature has been developed at Baird Atomic. A second array of detectors, parallel to the first, consists of 24 elements, each 0.04 by 0.04 inch, with 0.004 inch spacing between elements. All detector leads are brought out radially through the dewar wall using a 0.002 inch diameter low thermal conductivity copper-nickel wire. The detectors are cooled to 30°K by a closed cycle heat engine, probably employing Stierling technique. The particular choice of cooler will depend upon the technology at the time final design decisions must be made.

SPECIAL HANDLING

Table 4-2. Example Scanner Parameters.

	Array 1	Array 2	Sum of two channels & Elec. filtering
Aircraft Altitude	60K	1K	1K
Linear Field of View	1.25×10^{-4} rad	5×10^{-4}	10^{-3} rad
Number of channels	96	24	12
Ground Resolution	7.5 ft.	6"	1 ft.
Number of Resolution Elements- Cross-track			
(180° scan)	2.5×10^4	6.28×10^3	3.14×10^3
(120° scan)	1.67×10^4	4.2×10^3	2.1×10^3
Aircraft Velocity	2000 ft./sec	1000	1000 ft./sec
Number of Resolution Elements Along track	2.67×10^2	2×10^3	10^3
Scan Time (10% overlap)	0.325 sec	11.8×10^{-3} sec	11.8×10^{-3} sec
rpm (Scan Mirror)	1.54 rps	42.4 rps	42.4 rps
rpm (Scan Mirror)	92.5 rpm	2550 rpm	2550 rpm
Total number of Elemental Fields/Scan	1.67×10^6	10.1×10^4	2.52×10^4
Bandwidth (System Total)	3.85 mc	7.1 mc	1.78 mc
Bandwidth (per channel)	40 KC	592 KC	157 KC
Optical Diameter=10"			
Focal Length=80"			
Noise T	0.1°K	.05°K	.025°K
Weight	200#		
Power			
Scanner	200 watts		
Cooler	300 watts		
Volume	7 cu.ft.		

SPECIAL HANDLING

4-43

SPECIAL HANDLING

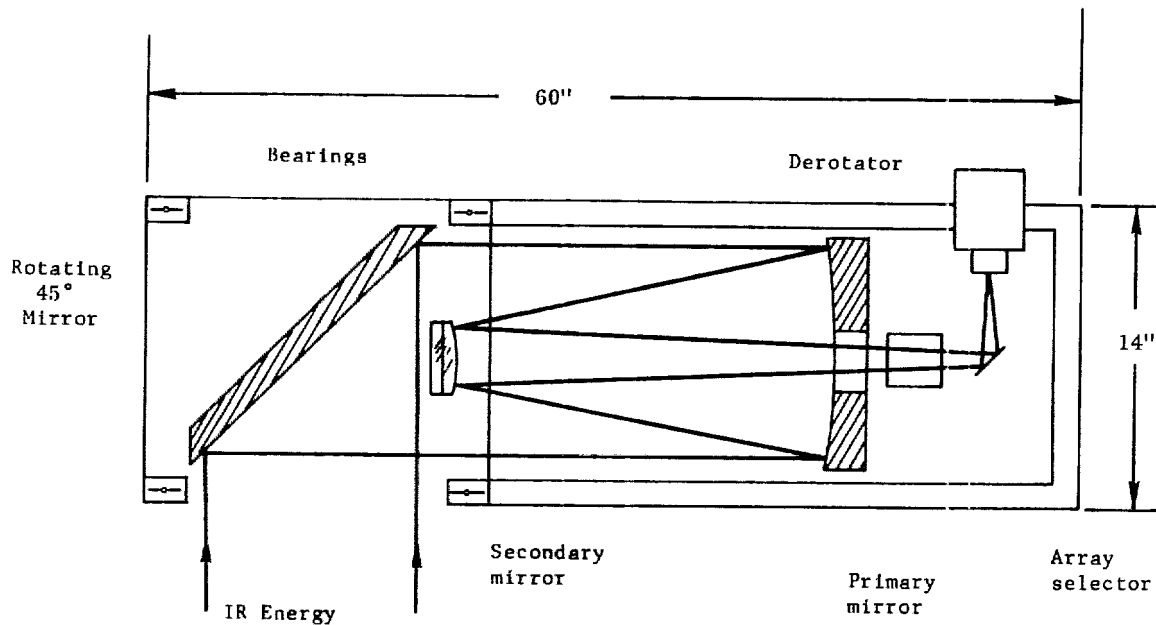

Fig. 4-20 — Infrared scanner optical configuration.

SPECIAL HANDLING

For a general reconnaissance the spectral response of the detectors will extend over the range from 3 to 14 microns. This has been shown experimentally to provide the best overall infrared imagery. For special purposes such as the detection of objects appreciably above room temperature, the spectral response may be restricted to the 3.5 to 5 micron interval. This spectral region enhances the contrast of hot objects against a normal temperature background.

Thermal shields within the detector dewar are employed to reduce the ambient radiation reaching the detectors. Recent experimental evidence shows that these detectors behave in a background limited fashion; hence their performance may be enhanced by limiting the field of view to that of the imaging optical system.

Signal Channel Electronics — A block diagram of the electronics associated with each detector element is shown in Fig. 4-21. The output of each detector is preamplified and impedance shifted so that additional processing may be performed without introducing extraneous noise. The response of each detector channel is controlled by an AGC element compared against a common reference voltage. An infrared calibration signal introduced by an auxiliary optical system is demodulated and used to determine the gain setting automatically for each channel. A logic circuit of the output of the signal amplifier samples the signal voltage upon command from an index pulse propagated from channel to channel. The resulting sample signal is then summed on a common buss so that separate leads need not be brought out from each individual channel. The time constant of the amplifier and propagation time of the index pulse is selected depending upon the V/h range.

The approach provides an electronic configuration which is amenable to produce techniques using microcircuits. Problems of lead interconnections are minimized because only common busses are required other than the initial connection between the detector and the preamplifier. Variation in detector response or electronic components is eliminated by the utilization of a common infrared calibration source and a common AGC reference voltage. This approach performs both the function of automatically adjusting channel responsivity and eliminating system drifts.

SPECIAL HANDLING

4-45

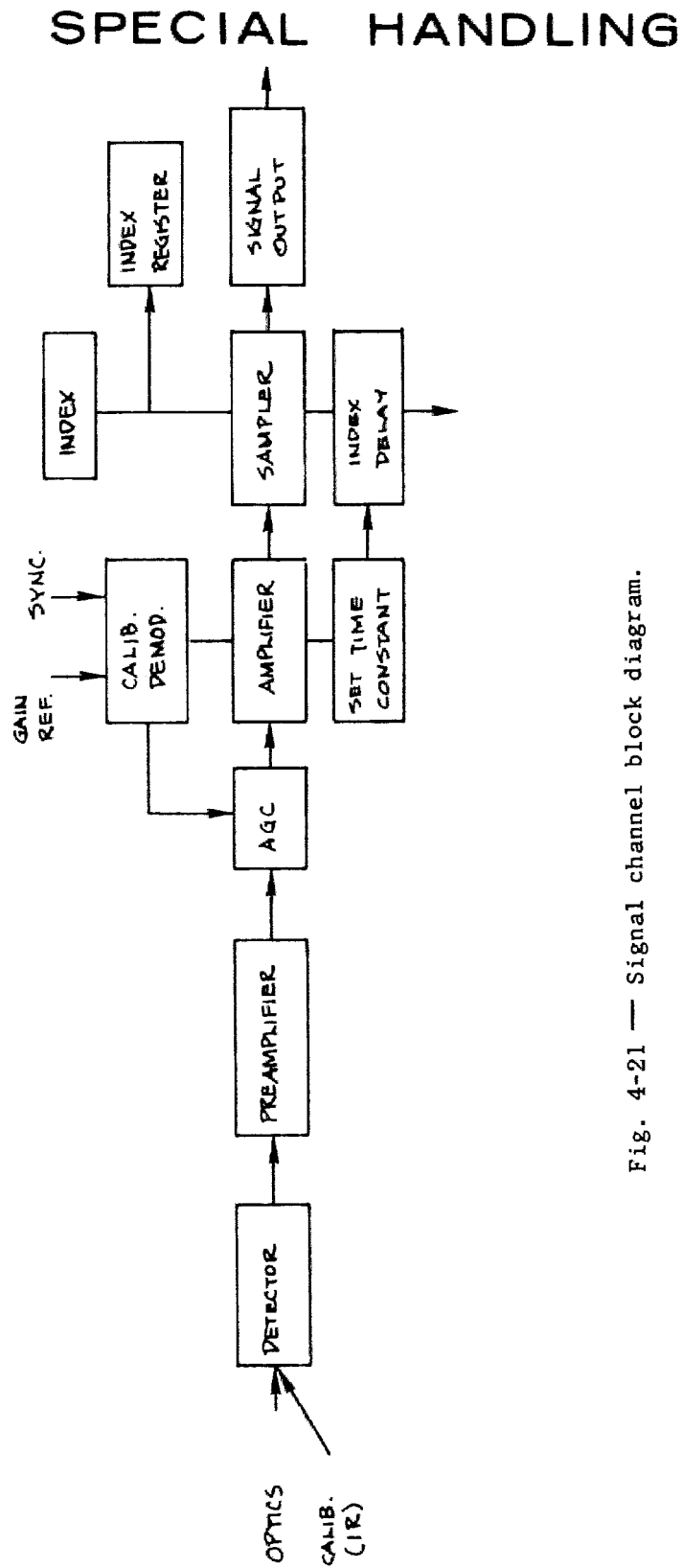

Fig. 4-21 — Signal channel block diagram.

SPECIAL HANDLING

4.2.2.2 Optimization of Spectral Interval

Certain infrared characteristics of the atmosphere, of targets, and of backgrounds have been previously discussed. These included the spectral independence of various target signatures, the infrared atmospheric transmittance from 2 to 20 microns, and the spectral nature of terrain detail. That technical data is here utilized to develop the requirements on optimization of the infrared sensor with respect to the choice of spectral interval.

There are three broad atmospheric windows in the range from 3 to 14 microns; their spectral limits are 3-4.2 microns, 4.5-5.5 microns, and 8-14 microns. Strong absorption bands are located at 4.3 and 6.3 microns. The 3.7 and 4.7 micron windows (wavelengths of peak transmittance) are located spectrally such that the radiance of high temperature sources of tactical interest may be from 200 to 1000 times that of the background. Thus, if the linear dimension of the target is only one tenth that of the linear field of view, adequate signal-to-noise ratios will still be produced for detection. This emission will be augmented by that which is seen through the 8 to 14 micron window, nominally used for the rendition of low contrast detail near ambient earth temperatures. This increment corresponds to about 30 percent of that due to the short wavelength emission; its spectral bandwidth is 3 times as wide, but the radiant amplitude is about 1/10 of the shorter wavelength emission.

The main atmospheric window from 8 to 14 microns is located spectrally near the maximum outgoing earth emission at ambient temperatures. Radiance differences due to local small-scale temperature and emissivity differences are easily sensed; their magnitude lies in the range from 1 to 10 degrees centigrade. It is interesting to note that a temperature change of 2.5 degrees produces a radiance difference corresponding to a change in emissivity of from 0.8 to 0.9.

Thus, the spectral requirements are simply stated. The higher temperature targets and the lower equivalent temperature sources associated with terrain detail indicate that an optimum infrared sensor for generalized tactical missions be operative spectrally in the broad range from 3 to 14 microns. This includes provision for filtering out unwanted solar reflection on the short

SPECIAL HANDLING

4-47

SPECIAL HANDLING

wavelength side of 3 microns. The 8 to 14 micron region is especially effective in rendering the low temperature detail, and extension of the spectral band to include the short wavelength emission of hot sources will provide the additional signal-to-noise ratio needed for threshold classification of keying data.

4.2.2.3 Airborne Data Processing

The output signals from the infrared scanner are processed to provide high resolution video recordings on magnetic tape and photographic film. Video data may also be transmitted directly in real time on a wideband data link and/or displayed to an observer. A block diagram of this portion of the system is given in Fig. 4-22.

Simultaneous automatic processing of the video information may be performed at the discretion of the operator to provide keying data as a guide to image interpretation. This processing consists of synthesizing (by channel summation) an effective elemental field of view corresponding to a target of interest and then thresholding the resulting signal. Exceeding the threshold causes identifying information, such as time and location, to be recorded in digital format on a separate channel. Also recorded is the digital representation of the signal which exceeded threshold. Table 4-3 is a tabulation of weight estimates for airborne data processing equipment.

Video Synthesis — The indexing and sampling system described in Section 4.2.2.1 produces an electric signal very similar to conventional non-return-to-zero pulse amplitude multiplexing (NRE-PAM). This type of data sampling is quite useful where minimum bandwidth is required and precise preservation of amplitude is not necessary. Synchronizing pulses are provided by adding an index pulse into the video signal every twelve channels. (See Fig. 4-22(a)). Frame synchronization and electrical calibration reference levels are provided between sweeps of the scanning mirror.

Film Recording — At the present time, the state-of-the-art in cathode-ray tube technology is such that fewer than 1/2 of the required number of resolution elements can be provided in a single line. Thus, it appears that an array of solid state light sources imaged through an optical scanner similar to the one

SPECIAL HANDLING

Table 4-3. Weight Estimates- Airborne Data Processing Equipment.

<u>Unit</u>	<u>Est.Wt</u>
Video Synthesis	2#
Electro-optical Converter and Film Transport	150#
Video Tape Recorder	175#
Opr.Display	50#
Data Key Processor	25#

SPECIAL HANDLING

SPECIAL HANDLING

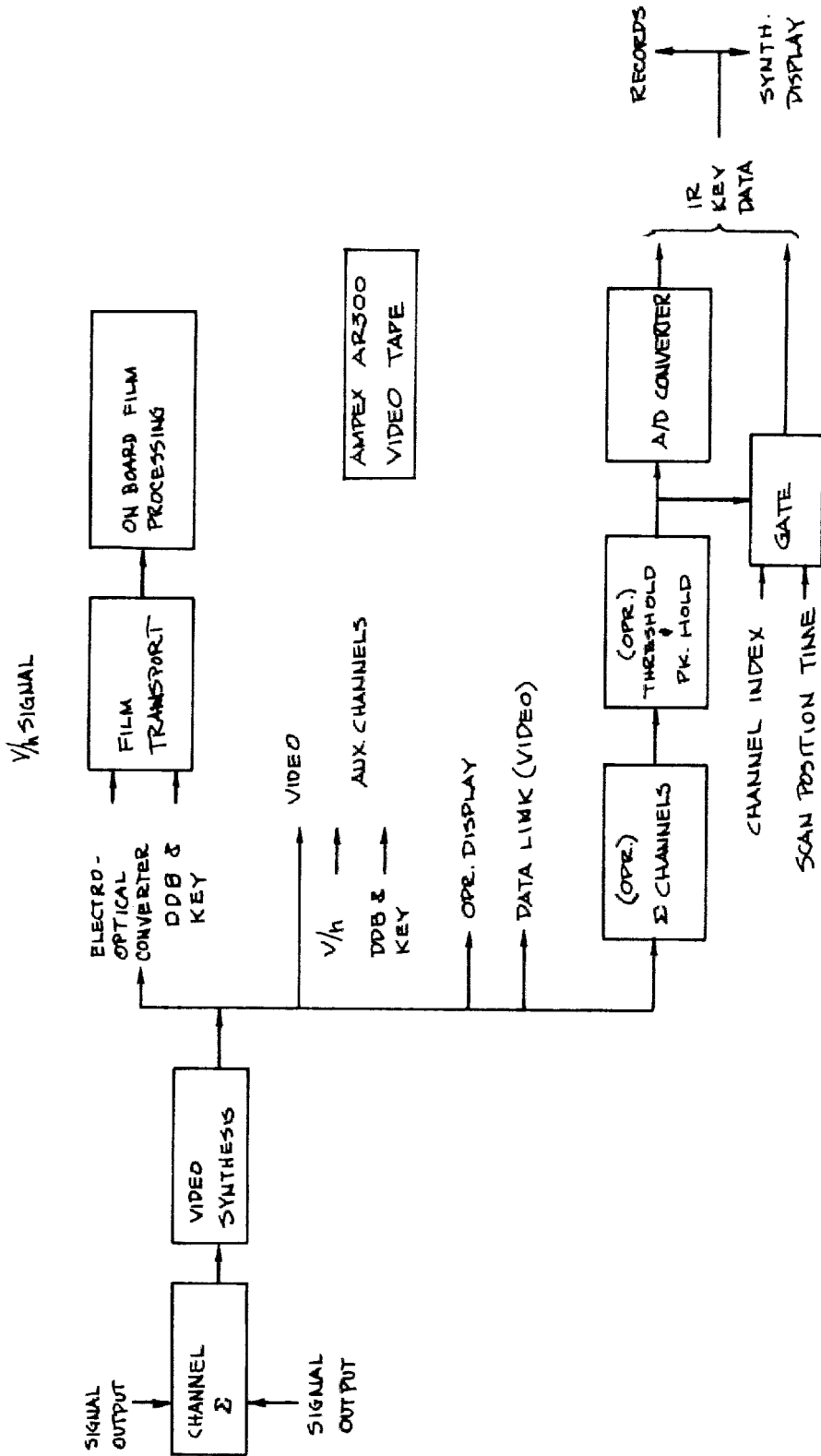

Fig. 4-22 — Airborne signal processing block diagram.

SPECIAL HANDLING

SPECIAL HANDLING

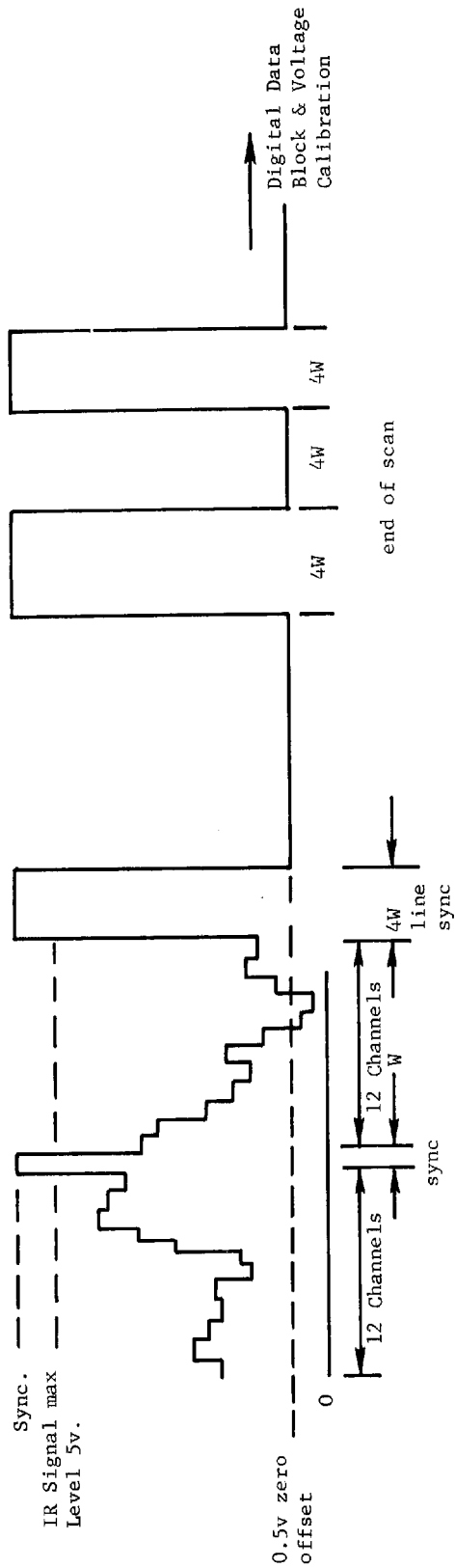

Fig. 4-22(a) — Idealized video waveform (end of mirror scan).

SPECIAL HANDLING

SPECIAL HANDLING

collecting the data is the only way to obtain full resolution capability of the infrared scanner and film combination. The film transport is servoed to the V/h sensor signal as is the optical scanning mirror. Also recorded on the film is a digital data block giving pertinent navigational and identifying information key data from the threshold processor is recorded in the form of coded dots on the margin of the film.

After exposure, this film is treated in the same manner as the photographic film in terms of onboard processing and storage.

Video Tape Recorder — The synthetic video signal is recorded directly on video tape. Presently existing equipment is available which will provide the required recording times and video bandwidths (for example, the AMPEX AR 300). One auxiliary channel on the tape is used to record V/h signals and operator voice commentary. The other auxiliary channel is used to record digital key information during the image scan and digital data block information between scans, while the mirror is reset.

The AR300 provides two 4-megacycle video channels simultaneous and two 15 KC auxiliary channels. The two 4-megacycle channels may be used to provide an equivalent 8-megacycle bandwidth with this type of scanner by recording half the infrared channels on one 4-megacycle track and the other half of the infrared channels on the other 4-megacycle track. Alternatively, the AR300 can be used to provide one 4-megacycle track for twice the previous recording time, i.e., one hour instead of 30 minutes.

If two infrared scanners are employed, the two 4-megacycle tape channels may be used independently, one to record the output of each scanner. If necessary, the bandwidth on one or both of the infrared scanners may be reduced to fall within the 4-megacycle limit.

Operator Display — In the past a major problem in real time display of infrared scanner data has been the lack of a method of retaining imagery once the aircraft has passed over a region. A solution to this problem has been recently developed by CBS Laboratories in the form of a moving phosphor belt electron beam display. Although it only produces 1200 TV lines across a 4.5 inch

SPECIAL HANDLING

SPECIAL HANDLING

face, this resolution should be adequate for navigational updating purposes. Because the resolution loss is in the display rather than the sensor, the detection of hot targets should not be appreciably degraded, particularly if the operator makes judicious use of brightness and contrast controls.

A synthetic display, generated by the keying data, may be superimposed upon the imagery. This synthetic display makes use of information from all of the sensors except for the photographic. Hence an operator may have his attention called to a particular area by a key signal from the radar MTI and examine this area for indication of a hot target or attempt shape identification by employing sweep expansion.

An alternative method for displaying imagery may be employed if the infrared scanner is of the repetitive framing type. A forward looking reconnaissance sensor has recently been built by Texas Instruments Company which produces a frame rate of six per second. Direct display on a medium persistence cathode ray tube produces imagery usable for low altitude missions and navigational assistance. Because the frame rate is sufficiently rapid that redundant information is obtained, detection of hot targets by the operator may be enhanced.

Video Data Link — The synthesized video information is also made available to a wideband data link. If sufficient bandwidth is available the video data will be transmitted at the full resolution taken by the scanner. However this may require in the vicinity of 10-megacycles or more. Channel summation may be performed on the infrared video signals to produce lower resolution information with a reduced bandwidth. Bandwidth reduction of an order of magnitude is readily accomplished; but the resulting information will probably be useful only for increasing the interpreters confidence in other information, rather than direct identification. Useful data for large targets, i.e., bridges, airfields, etc., will be maintained, as will navigational data.

Priority Data Link — A second narrowband data link is employed to transmit keying data from the various sensors independently from the video data link. In the case of the infrared sensors the key data contains information as to the position and magnitude of bright infrared sensors. This information is in

SPECIAL HANDLING

SPECIAL HANDLING

digital format so that it may be readily coded to reduce jamming susceptibility. The bandwidth of the uncoded data will probably not exceed 1 KC.

Automatic Selection of IR Key Data — The electronic processing employed to select key data consists of the following processes: 1) summation of channels and electronic filtering to synthesize selected fields of view, 2) electronic thresholding of the resulting signal and peak holding of those signals which exceed threshold, 3) conversion from analog to digital representation of the peak voltage, 4) gating of the channel index, scan position, time of threshold exceedance, and signal amplitude onto the key buss as a single digital word. This is then distributed to the records and to the synthetic display, as well as the priority data link. The number of digital bits required for the key data is in the range of 18-30 depending on the required resolution. The scan position and channel index may be converted to coordinates in latitude and longitude by using the navigation data and computing the ground intercept of the line of sight.

Carrier Data Processing — The high resolution film record processed in the aircraft is carried directly to the data analysis and correlation center. The magnetic tape containing the infrared data is carried to the tape library. High priority sections of the imagery are selected for initial analysis based on the key records. If further information is desired, the analyst may request data from the magnetic tape. Tape data may be displayed on a cathode ray tube or printed out on a typewriter. Disposition of the data is decided upon by the analyst. A block diagram of carrier based data processing for infrared is shown in Fig. 4-23.

Processing of the Magnetic Tape Data — A tape playback unit compatible with the airborne recorder is the AMPEX FR700. The output of the auxiliary channels containing digital data block and key data is fed to a tape search computer and buffer unit. High speed tape search is initiated until comparison of the data block register and data request are identical. The requested data is then read from the tape, converted to digital format, and placed in buffer store. If only a small section of a scan is required, this is then located by utilizing the line-scan sync pulses. These are readily identified by comparison

SPECIAL HANDLING

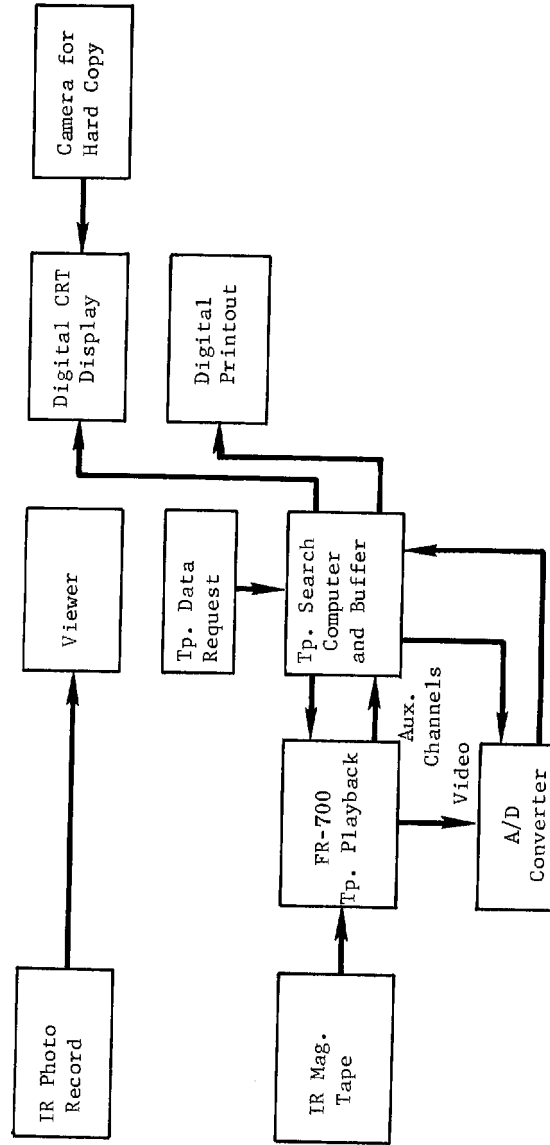

Fig. 4-23 — Carrier based data processing.

SPECIAL HANDLING

SPECIAL HANDLING

of the high order buffer bits. Once the requested information has been located, it may then be displayed with a variable scale factor on a digital CRT display or printed out on a typewriter. Hard copy of the digital CRT display is produced by photographing the display.

4.2.3 High Resolution Side Looking Radar Sensors

4.2.3.1 Operational Considerations

Low Altitude and High Altitude Missions — The requirements of low altitude and high altitude missions place different requirements upon the performance of a synthetic array reconnaissance radar. For low altitude missions the coverage is usually restricted by the shadowing effect at low grazing angles, while for high altitude missions the coverage is usually restricted by the amount of recording capacity that can be included in the radar system. The maximum range for high altitude missions can be set by the amount of average power, the grazing angle, or ambiguity considerations.

For low altitude, short range missions which map preselected targets, it is possible to employ a conventional radar and still obtain reasonable azimuth resolution. In the high altitude, wide coverage mission, however, reasonable azimuth resolution can only be obtained by synthetic-array radar techniques. For the limited amount of coverage obtained on low altitude missions normal photointerpretation techniques can be employed for target recognition. In the wide coverage, high altitude missions, the amount of data per mission could saturate the reconnaissance analyst unless some data selection is performed. This data selection can best be done by change detection techniques which call attention to those areas where there are changes in radar return.

Effect of Weather and Dense Foliage — Because of weather attenuation, the useful radar frequency range is K-band and below. Even at K_a -band there is fairly severe weather attenuation and backscattering when light rain is present. At X-band almost all of the atmospheric attenuation, weather attenuation, and clutter effects have disappeared. However, the K-band frequency range has better contrast between such low reflectance targets as concrete, dirt, grass, etc. For low altitude, short range missions, the effect of weather can be

SPECIAL HANDLING

ignored and this would indicate that K-band would be the best operating frequency to obtain good radar imagery. However, for long range high altitude missions, X-band is to be preferred.

To penetrate dense foliage, and camouflage requires the use of low radar frequencies, for example, 1 meter RF wavelength.

Effect of Timeliness — The time scales of importance in radar sensor design are fifteen minutes and two hours. The fifteen minute figure pertains to obtaining information in time to change the mission of the next reconnaissance sortie or to change the armament and mission of the attack force on the next flight. This timeliness is especially important for fleeting targets in a battlefield environment. Because of the flight time and data recovery times involved, the fifteen minute figure can only be met by the use of a data link to send priority information. Because of data link bandwidth considerations only selected data can be transmitted, and because of the interpretation times involved only data which is not subject to long interpretation will be valuable.

For the radar sensor the moving target indication information falls in this category of priority information. Therefore, a real time inflight processor for moving target indication should be employed and the output of this processor should be both presented to the observer on the aircraft and sent by data link to the carrier. On the carrier the priority analyst will be presented with this moving target information along with other alerting and keying information from other sensors in order to make a decision for the next strike and subsequent strikes.

Another form of operation where near real time processing will be valuable is for battlefield surveillance. To best utilize the radar in a timely manner it is necessary to fly at high altitudes and maintain continual data link contact with the carrier. By the use of repetitive surveillance missions the imagery data which is sent via data link to the carrier can be processed and compared to previous imagery by change detection methods. To make maximum use of this information for programming attack missions the delay in this processing and change comparisons must be kept to times on the order of fifteen minutes for fleeting targets.

SPECIAL HANDLING

4-57

SPECIAL HANDLING

The bulk of imagery data, especially on wide coverage missions, will be physically recovered on the carrier. Film processors and signal processors that obtain the output imagery used for data and target interpretation should operate so that output images are available in under an hour, which means that most of the reconnaissance information can be obtained in under two hours. In cases where high quality photography has been obtained of the same areas being covered, the radar will not be used for detailed interpretation but for keying large cross-section targets and indicating changes in the radar imagery. This keying data will enable a photo-interpreter to inspect in detail these locations on the photography.

Effect of Employing a Multisensor System — In a multisensor reconnaissance system, as discussed above, moving target indication, large cross-section indication, and change detection can be used to key locations on the other sensor imagery for detailed interpretation. Likewise, infrared hot spot and ELINT emitter location keys can be used to point out on the radar imagery locations of potential targets. This is especially important in bad weather conditions where good photography cannot be obtained, or in inspecting wide coverage radar imagery obtained at long off-set ranges.

Optimization Procedures — The multisensor tactical reconnaissance system and, more specifically, the radar sensor should be optimized with respect to mission effectiveness. The mission effectiveness criterion is in terms of the probability of success of obtaining meaningful intelligence information. One aspect is the probability of success in the interpretation of imagery data. Another aspect is the probability of success in obtaining alerting and keying information of prime military movements. As a first step in this program a comprehensive tactical target list was drawn up in order to outline the characteristics of interesting targets which can be measured by the sensors. The performance of the individual sensors against these types of targets was then studied.

Figure 4-24 illustrates the interconnection between requirements and system parameters for a synthetic array reconnaissance radar. The requirements are in terms of aircraft performance; radar weight, power, volume, and

SPECIAL HANDLING

OPTIMIZATION PROCEDURES (MISSION EFFECTIVENESS APPROACH AND COST EFFECTIVENESS APPROACH)

USE MISSION RADAR EFFECTIVENESS APPROACH IN TERMS OF PROBABILITY OF SUCCESS IN INTERPRETATION

REQUIREMENTS

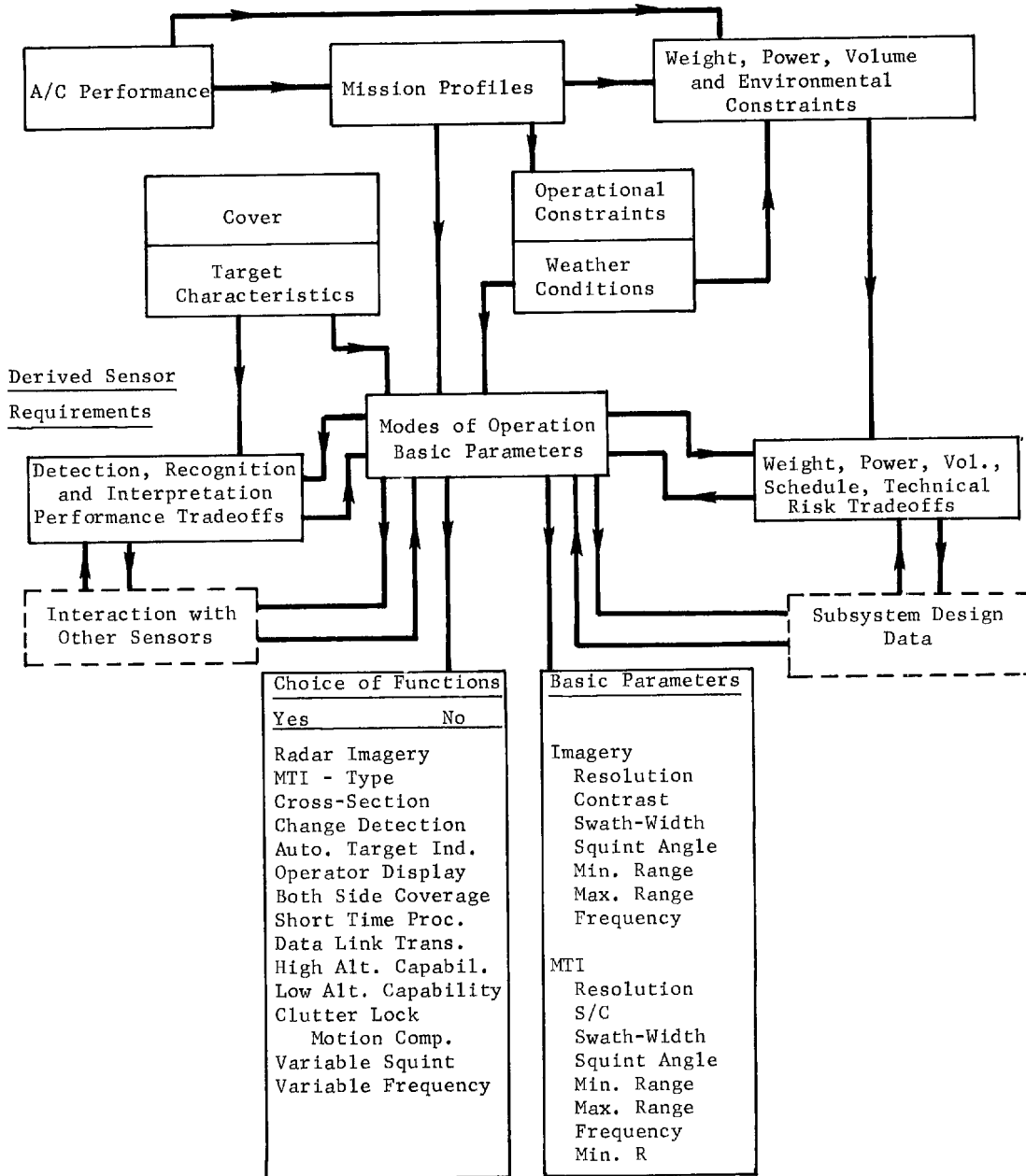

Fig. 4-24 — Interconnection between requirements and system parameters for a synthetic array radar.

SPECIAL HANDLING

SPECIAL HANDLING

environmental constraints; mission profiles and target characteristics; operational constraints and weather conditions. With these requirements in mind the basic modes of operation of the radar sensor are determined by detection, recognition and interpretation performance trade-offs by interaction with other sensors; by weight, power, volume, technical risk trade-offs; and by knowledge of the state-of-the-art in radar subsystem design.

The basic parameters for imagery and change detection are resolution, contrast, range swath width, squint angle, minimum range, maximum range, frequency, and accuracy of location. The basic parameters for moving target indication are resolution, signal-to-ground clutter ratio, range swath width, squint angle, minimum range, maximum range, frequency, and minimum detectable closing rate. The different functions that the radar can perform are radar mapping, moving target indication, large cross-section detection, change detection, inflight real time processing, data link transmission, variable squint operation, variable resolution operation, and possibly variable frequency operation. Figure 4-25 shows a parameter derivation flow chart which connects the input requirements and the choice of parameters for the system.

SPECIAL HANDLING

SPECIAL HANDLING

PARAMETER DERIVATION FLOW CHART
 SYNTHETIC ARRAY RADAR - IMAGERY

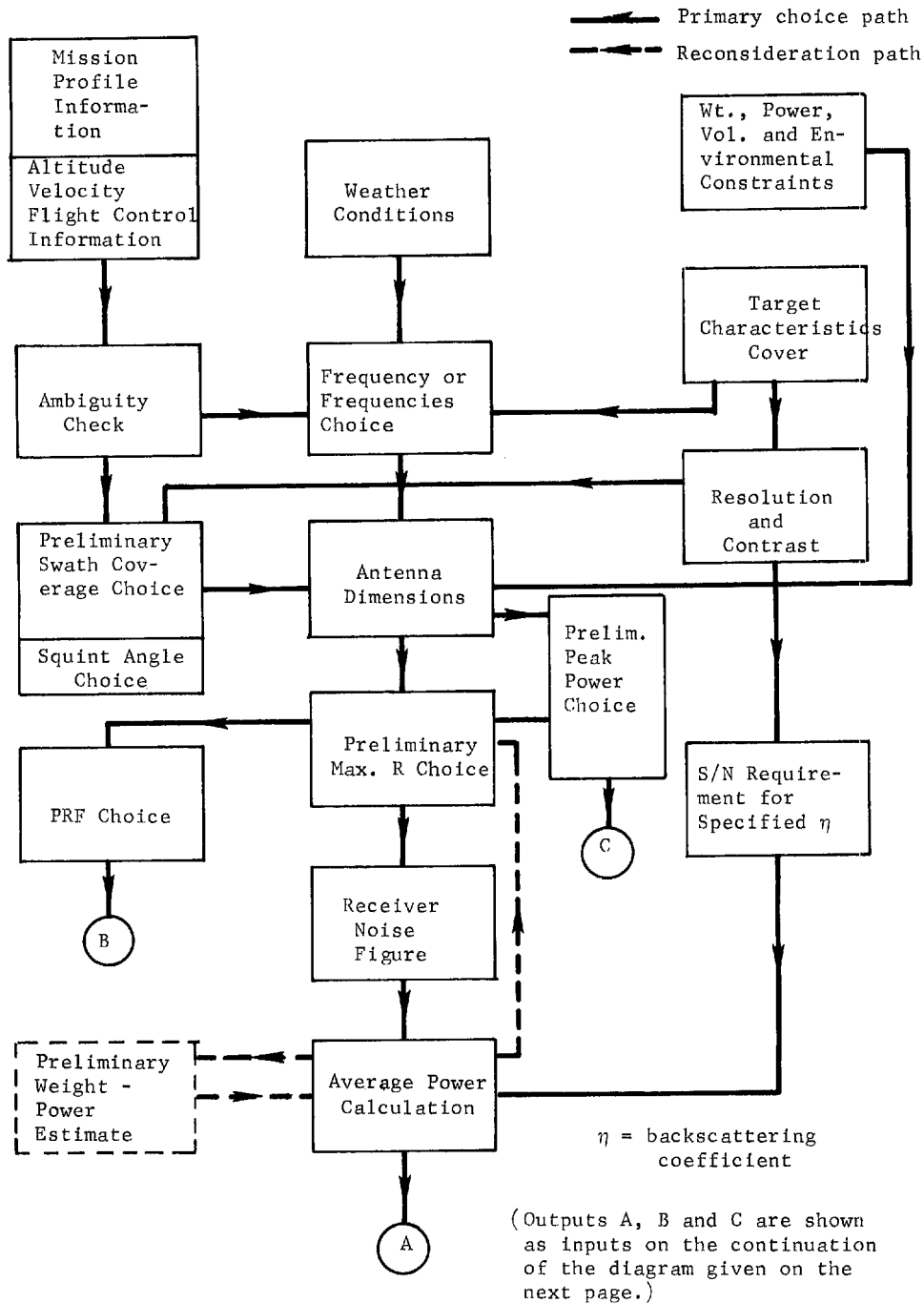

Fig. 4-25 — Parameter derivation flow chart synthetic array radar imagery.

SPECIAL HANDLING

IF REQUIRED

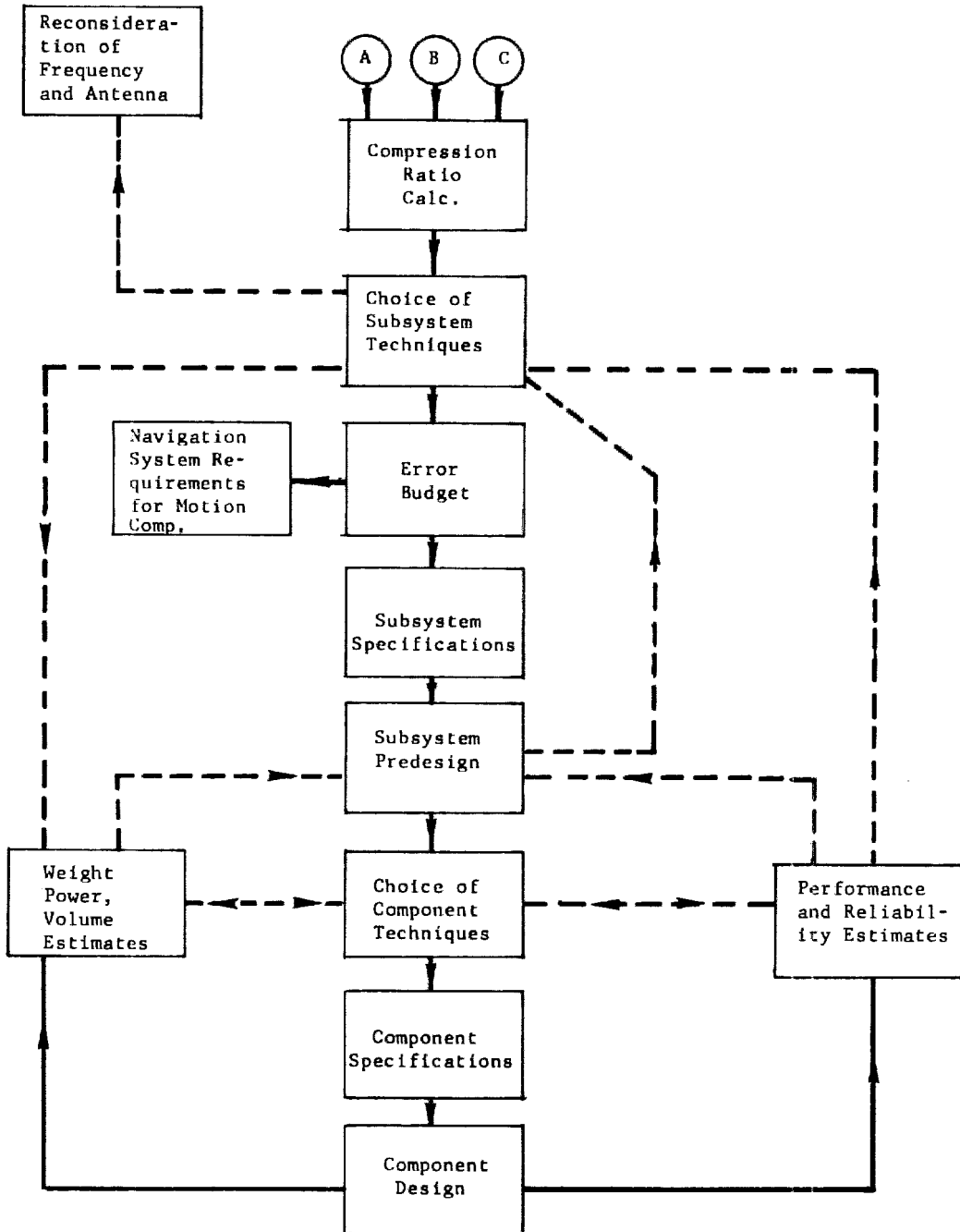

Fig. 4-25 — (Cont.)

SPECIAL HANDLING

SPECIAL HANDLING

4.2.3.2 Radar Sensor Configurations

The possible subsystems for the synthetic-array radar are shown in Fig. 4-26.

The essential functional elements for the radar system are identified in Fig. 4-27. Microwave energy is generated in the transmitter, passed through the duplexer and radiated from the antenna toward the selected target area. The returning scattered radiation is passed through the duplexer to the receiver and thence to the recorder or telemeter link subsystem. A signal processor is provided, either as carrier based equipment or as airborne equipment to convert the recorder radar signals into a focused map image. Inertial motion measuring instrumentation is provided to correct the radar data for irregularities in the motion of the aircraft. Inertial equipment will also provide appropriate inputs for scaling, orienting, and restituting the map images. The antenna is stabilized by use of information from the inertial platform so that the antenna beam will always point at the appropriate squint angle.

There are four configurations which can be considered in the design of the mapping function for such a radar:

1. The radar signal is recorded by an airborne recorder. The recording is delivered upon landing on the carrier to a data processor unit where the radar images will be produced. A simplified layout sketch of an airborne recorder is shown in Fig. 4-28.
2. The radar signals may, instead of or in addition to the above, be transmitted in real time via a line of sight wideband telemeter link to the processor unit on the carrier.
3. The radar signal will be recorded as in configuration 1., but the film is developed in flight and then read out when convenient with a flying spot scanner in the form of an electrical signal which can be sent over the data link. This technique allows bandwidth reduction.
4. The radar signal will be recorded as in 1., but radar images will then be produced immediately by an airborne processor and displayed to the aircraft crew for the monitoring of radar operation output, for limited data interpretation, or selective graphic transmission.

SPECIAL HANDLING

4-63

SPECIAL HANDLING

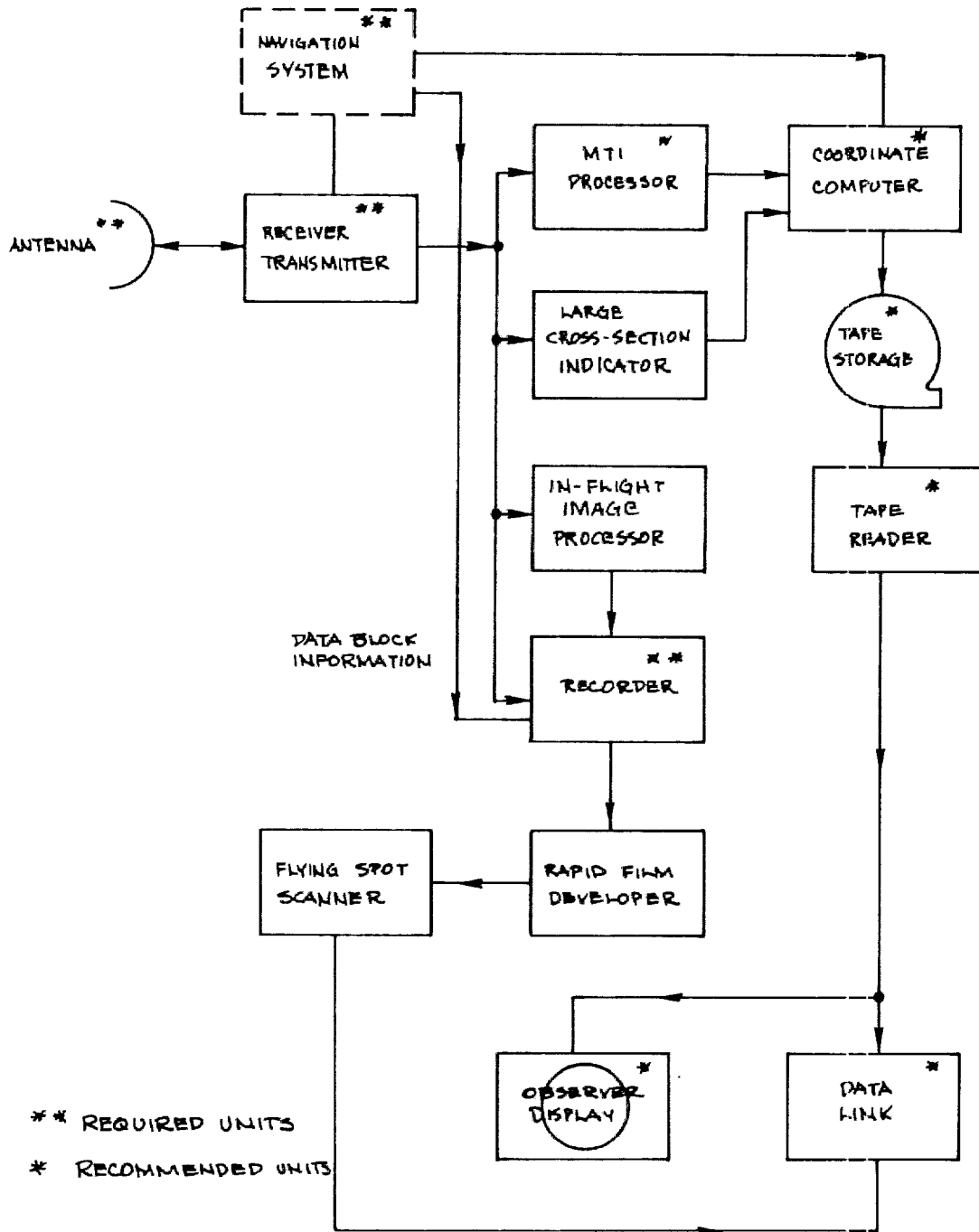

Fig. 4-26 — Possible radar sensor subsystems.

SPECIAL HANDLING

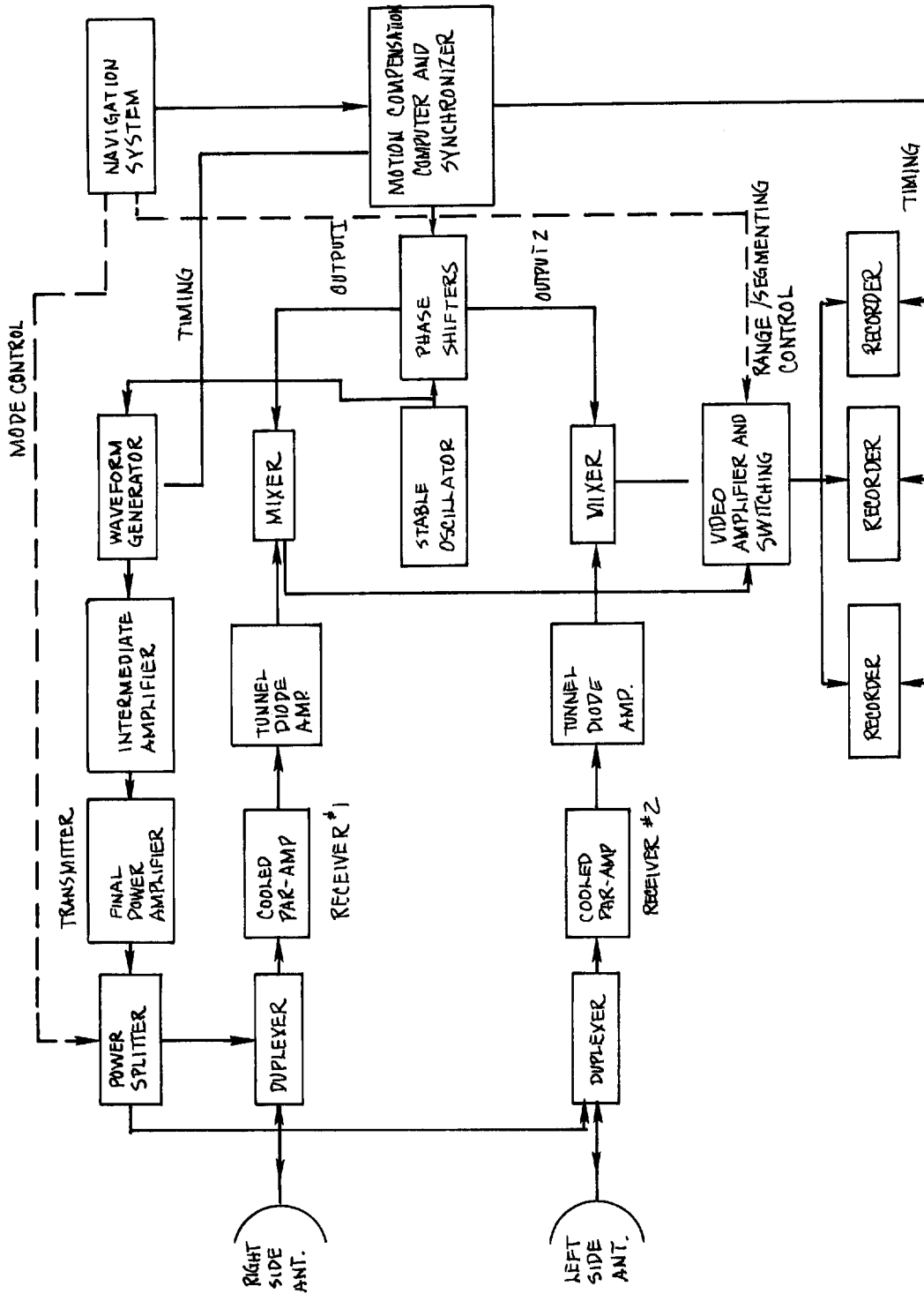

Fig. 4-27 — Radar unit block diagram.

SPECIAL HANDLING

SPECIAL HANDLING

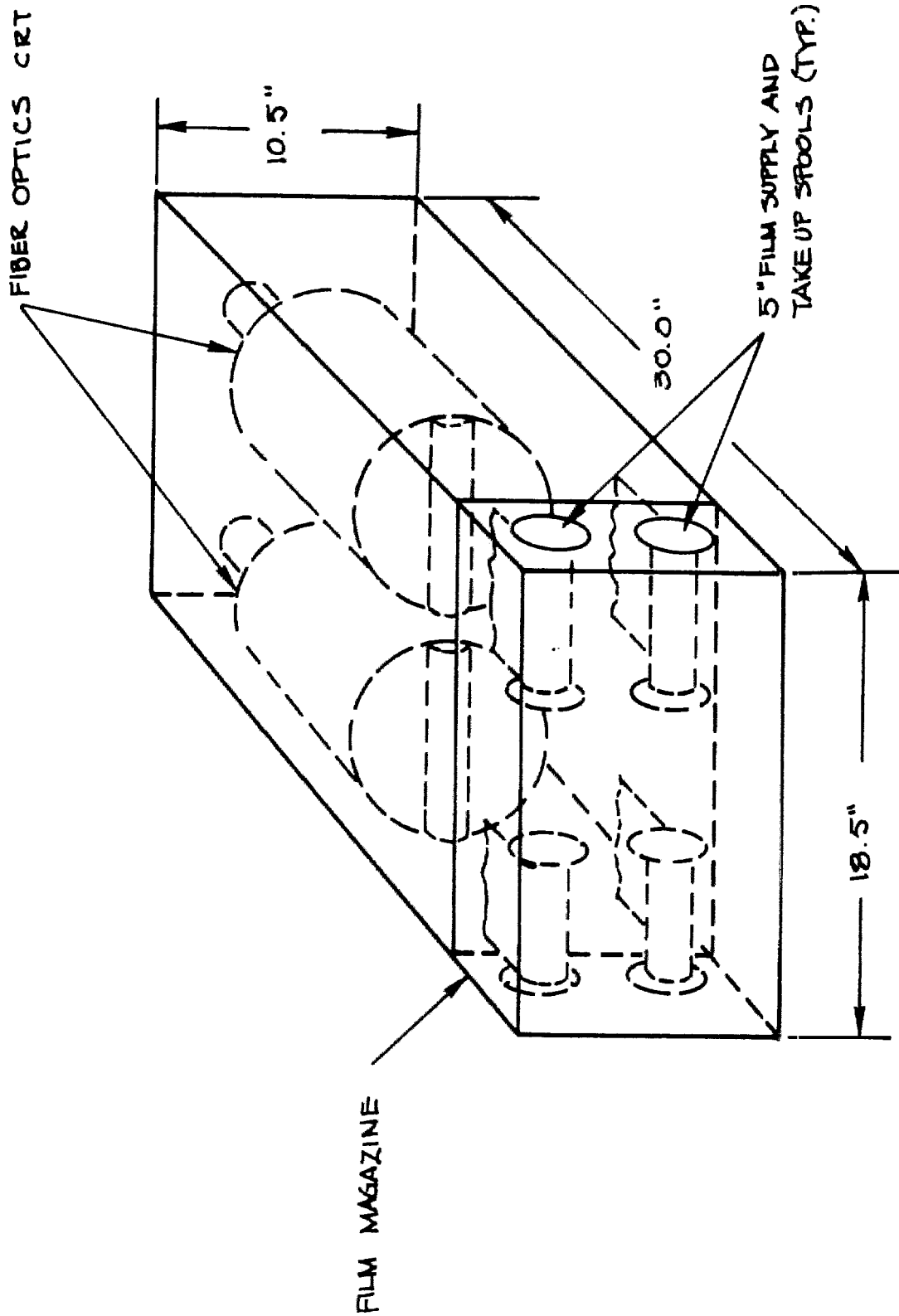

Fig. 4-28 — Dual channel airborne recorder.

SPECIAL HANDLING

SPECIAL HANDLING

The first configuration involves the minimum amount of aircraft equipment which is used for radar imagery. Recorders would always be added to configuration 2, for low altitude missions since data link transmission cannot be assured in this geometry. The additional equipment required for configurations 3 and 4 probably does not add enough additional capability to justify the additional weight and volume. On the other hand an inflight processor for MTI should be added since this provides valuable alerting and keying information. The parameters and weights for the units shown in Figs. 4-26 and 4-27 are given in the following section.

4.2.3.3 System Parameters and Operating Characteristics

This section will consider the parameters and operating characteristics of the basic building blocks of a synthetic-array radar reconnaissance sensor. These include:

1. High Frequency (X-band or K-band) Basic Radar
2. Low Frequency (1 meter wavelength) Foliage Penetration Radar (Pod Configuration)
3. Recorders, and
4. MTI Processor

The recommended configuration is the Basic High Frequency Radar, MTI processor and, to permit the most coverage, as many recorders as space and weight will permit.

In areas where targets may be hidden in dense foliage, a pod containing the low-frequency radar can be added possibly along with the removal of other sensor units to keep the same overall weight. A pod configuration is recommended rather than module replacement because of the difficulty of antenna replacement.

High Frequency Basic Radar — It is, of course, not possible to choose specific parameters for a radar for a tactical reconnaissance aircraft without knowing the aircraft configuration. However, various tactical reconnaissance fine resolution radar system designs have been considered at Conductron and the

SPECIAL HANDLING

SPECIAL HANDLING

list of parameters and techniques given in Table 4-4 illustrates the principal features of such a radar. The projected parameters for the 1970 era are based upon a design which is a derivative of the Conductron Corporation AN/APQ-108 Radar. The table illustrates steps in this derivation.

In many tactical reconnaissance applications, the total maximum ground coverage is set by the weight and volume that can be allotted to the recorders and there is a choice between selectable wider coverage on one side of the aircraft at a time or a narrower coverage for both sides simultaneously. There is also a choice between full coverage at gross resolution or fine resolution over a narrow region.

For a fine resolution radar in a tactical aircraft with coverage on both sides of the aircraft, two antennas mounted on opposite sides of the aircraft would be employed. These antennas are fed in parallel from a command transmitter so that imagery from both sides of the aircraft is obtained simultaneously. The power figures shown in columns 2 and 3 of Table 4-4 reflect this power division.

Since the purpose of motion correction is to correct for the phase centers of these antennas, the inertial platform should be placed as nearly as possible between the antenna phase centers. This will minimize errors due to aircraft flexure and will simplify the calculation of the correction term, due to the elimination of a long "lever arm" between the platform and the antenna phase centers. In any case, separate motion correction computations must be made for each side.

A weight estimate for the "A" design shown in Table 4-4 is given in Table 4-5.

Low Frequency Foliage Penetration Radar — To best penetrate foliage and not lose excessive range resolution in the ground plane, it is best to operate at depression angles below the horizon of between 30 to 60 degrees. If the aircraft altitude is 7 miles, the range at a 30 degree depression angle is 14 miles while the range at a 60 degree depression angle is about 8 miles; thus, the total slant range swath width is approximately 6 miles which corresponds to a ground range swath width of about 8 nautical miles. At an altitude of 6 nautical miles the range at a 60 degree depression angle is about 7 miles. If we let the slant

SPECIAL HANDLING

SPECIAL HANDLING

Table 4-4 — Comparison of Radar Characteristics

	<u>AN/APQ-108</u>		<u>"1970 Radar"</u>		B
Range	100 nautical miles	2 ft at 50 nautical miles	2 ft to 60 nautical miles		
Resolution	8 ft	8 ft at 100 nautical miles	4-6 ft at 100 nautical miles		
Power (av.)	4 KW (one side) Sidelooking	1 KW (per side) Sidelooking	2 KW (per side) Sidelooking (or 45° Squint with Resolution 3 ft at 40 miles)		
Beam Pointing - Horizontal Vertical	Mechanical Mechanical	Mechanical Electrical	Electrical Electrical		
<u>TRANSMITTER</u>					
Reference	Solid State	Solid State	Solid State		Solid State
Waveform Generator	BWO	Solid State	Solid State		Solid State
Low Level Amplifier	TWT	TWT	TWT		TWT
Intermediate Amplifier	TWT	CFA	CFA		1 or 2 CFA
High Level Amplifier	5 CFA	CFA	CFA		CFA
Modulators	Hard Tube	Magnetic	Magnetic		Magnetic
<u>ANTENNA</u>					
	Pillbox Fed Dish	2-Section Waveguide Array	Segmented Array		Segmented Array

SPECIAL HANDLING

SPECIAL HANDLING

NOTES FOR TABLE 4-4:

BWO	Backward Wave Oscillator
TWT	Traveling Wave Tube
CFA	Crossed Field Amplifier
Paramp	Parametric Amplifier
A Design	Reasonable extrapolation to 1968 to 1970 time era (weight estimates based on A system)
B Design	More advanced system

SPECIAL HANDLING

4-71

SPECIAL HANDLING

Table 4-5. Weight Estimates for "A" Design

	<u>Weight Pounds</u>
Transmitter	350
Receiver	225
Antenna	350 (both sides)
Recorders	(see Recorder Section)
Phase Correction Computer and Synchronizer	50
Self-Test, Controls, Junction Boxes and Cables	<u>300</u>
TOTAL (exclusive of recorders or data link)	1275

SPECIAL HANDLING

range swath width again be 6 nautical miles the maximum range will be 13 miles which occurs at a depression angle of 27.4 degrees.

From the above discussion we will establish a geometry for this mission. Let the aircraft altitude be 6.92 nautical miles. The depression angles will be set as those which lie between 27 and 60 degrees. A diagram illustrating this geometry for both sides of the aircraft is shown in Fig. 4-29.

System Parameters

PRF = 1200 pps (one side), 2400 pps (both sides).

R = Maximum Range = 13.2 nautical miles = 7.92×10^4 feet.

T_R = Noise Temperature = 1110° Kelvin.

v = Maximum Velocity = 1000 feet/second.

δ = Resolution = 15 feet.

S/N = Signal to Thermal Noise Ratio = 15 db.

F = System losses + Foliage loss = 4 db + 10 db = 14 db.

G = Antenna Gain = 12 db.

λ = Wavelength = 3 feet.

σ = Target Cross-Section = 0.5 square meters.

P_a = Average Power = 25 watts.

POD EQUIPMENT SIZE AND WEIGHT (Including Recorders)

	<u>Volume (ft³)</u>	<u>Weight (lbs)</u>	<u>Power Cons. (watts)</u>
Radiate One Side	18 cu. ft.	1100 lbs	2400 watts
Radiate Both Sides	22 cu. ft.	1300 lbs	3000 watts

SPECIAL HANDLING

4-73

SPECIAL HANDLING

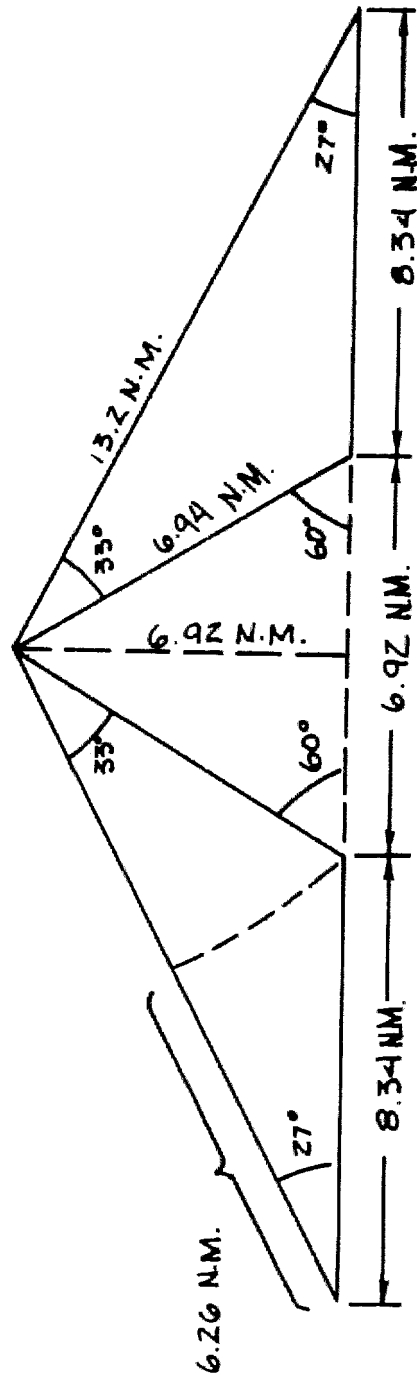

Fig. 4-29 — Range coverage.

SPECIAL HANDLING

SPECIAL HANDLING

This system is designed to look for jeep size vehicles. Our best estimate of the root mean square cross-section of a jeep for an RF wavelength of 1 meter is 0.5 square meters which is equivalent to about 5 square feet. The receiver noise temperature shown above allows for a 4.5 db noise figure looking into the receiver terminals and an antenna temperature of 290 degrees Kelvin. There is a duplexing network interconnecting the receiver and transmitter to the antenna which has transmission losses. We must allow for the two-way loss encountered when traversing the foliage. We will allow for a two-way foliage loss of 10 db which is 6 db higher than the average foliage attenuation measured in the Conductron measurements program.

Recorder Description — Space and weight limitations usually preclude recording of the entire swath illuminated by the radar. Each five inch film covers a separate range segment, and these segments may be made to lie adjacent to each other to provide continuous coverage.

The modular design of the recording process also permits segmented recording as shown in Fig. 4-30. Here the recorders first map a continuous range swath to cover one target area, then map two non-adjacent areas at other ranges, and subsequently map a third, continuous swath. This recorder switching can be pre-programmed into the navigator if desired. Not shown in Fig. 4-30, but equally simple to implement, is switching of recorder coverage to map returns from the opposite side of the aircraft. Since this switching can be done singly or in groups, optimum use of the total recording capability can be achieved at all times.

Airborne recorders for synthetic-array radars have been designed, fabricated, and tested on the Conductron Corporation AN/APQ-108 (XA-1) radar program. An engineering evaluation has been performed to determine the feasibility of utilizing the concepts and key components of this design for a miniaturized dual channel broadband recorder. The recording unit which is described immediately below can be made today with the present state-of-the-art components. The characteristics are summarized in the following table:

SPECIAL HANDLING

4-75

SPECIAL HANDLING

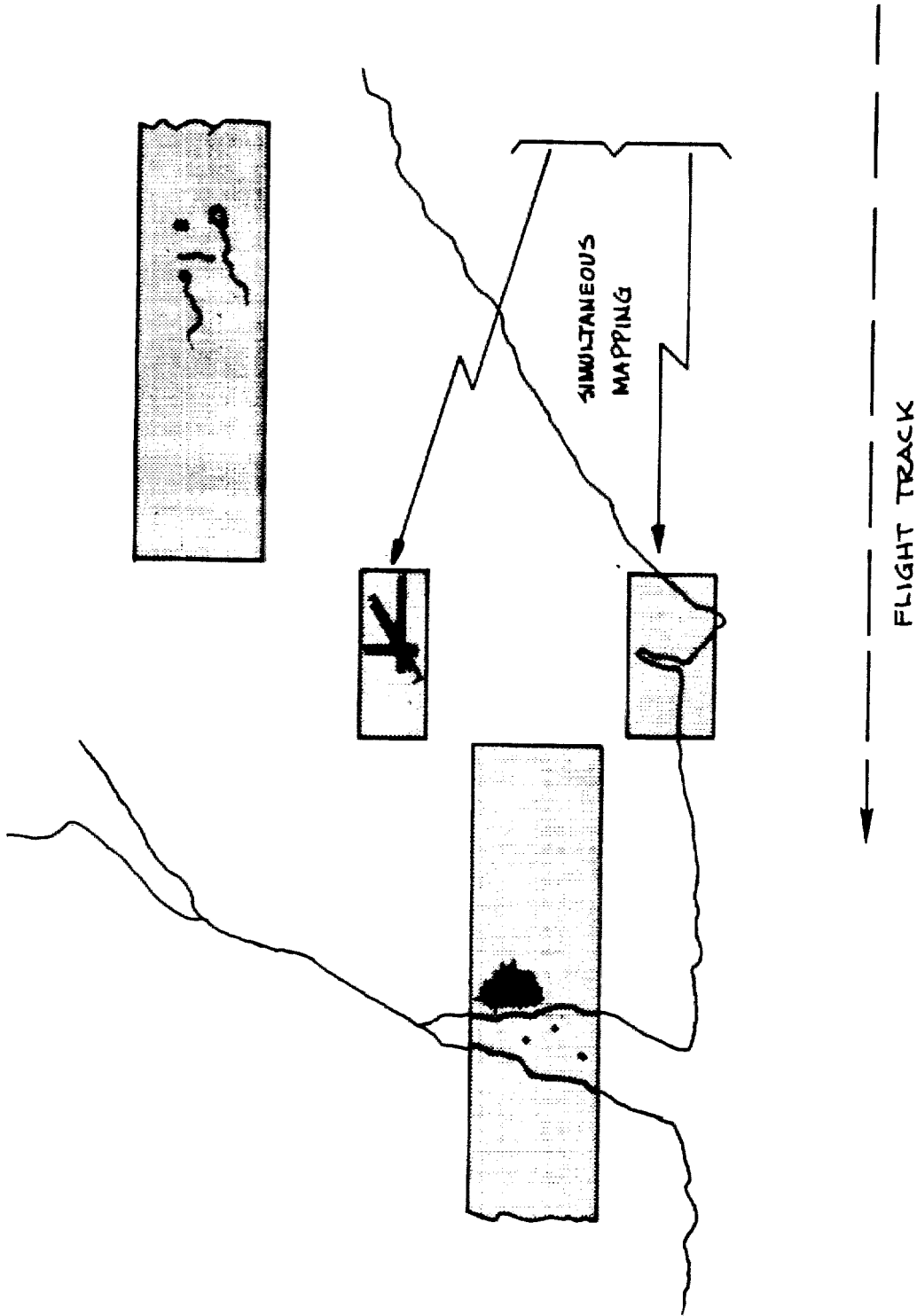

Fig. 4-30 — Segmented recording.

SPECIAL HANDLING

Recording Channels	two 5 inch films
Volume	4 cu.ft.
Weight	150 lbs
Recording Density	40 line pairs per millimeter
Total Recording Capacity	8000 range resolution elements for the two films plus data block information

By 1970 it is expected that this present day capability will be extended to 80 line pairs per millimeter recording density and that the weight will be reduced to approximately 100 pounds. These improvements in performance are illustrated by the graphs given in Fig. 4-31.

The dual channel recorder records video frequency signals over a wideband width on 5-inch photographic recording film. The film is exposed by passing it at a specified rate over the curved fiber optics face plate of a cathode ray tube which has a linear sweep and is intensity modulated by the video input signal. Two 5-inch film recordings are made from two CRT's. The dual channel recorder configuration is shown in Fig. 4-28. A single capstan motor with dual coaxial output shafts drives both recording films at a film speed proportional to the frequency of an input pulse train which in turn is made proportional to the aircraft velocity.

The electronics required for signal amplification, CRT sweeps, and the power supplies are built into the basic recorder. The film spools are situated such that they can be easily removed at the carrier without the necessity of removing the entire recorder. Inflight film developing units and flying spot scanner readout units can be incorporated into the recorder design at the expense of additional weight and volume.

Moving Target Indicator Processor — The moving target indication processor can be mechanized with currently existing 2-gun storage tubes as shown in Fig. 4-32. The capability of the storage tubes is approximately 600 range elements. This corresponds to 1 nautical mile swath coverage at 10 feet resolution, or 5 nautical mile swath coverage at 50 feet resolution.

The coherent radar video data from the receiver is recorded on electrostatic storage media in the tube. Orthogonal scanning of the readout electron beam

SPECIAL HANDLING

4-77

SPECIAL HANDLING

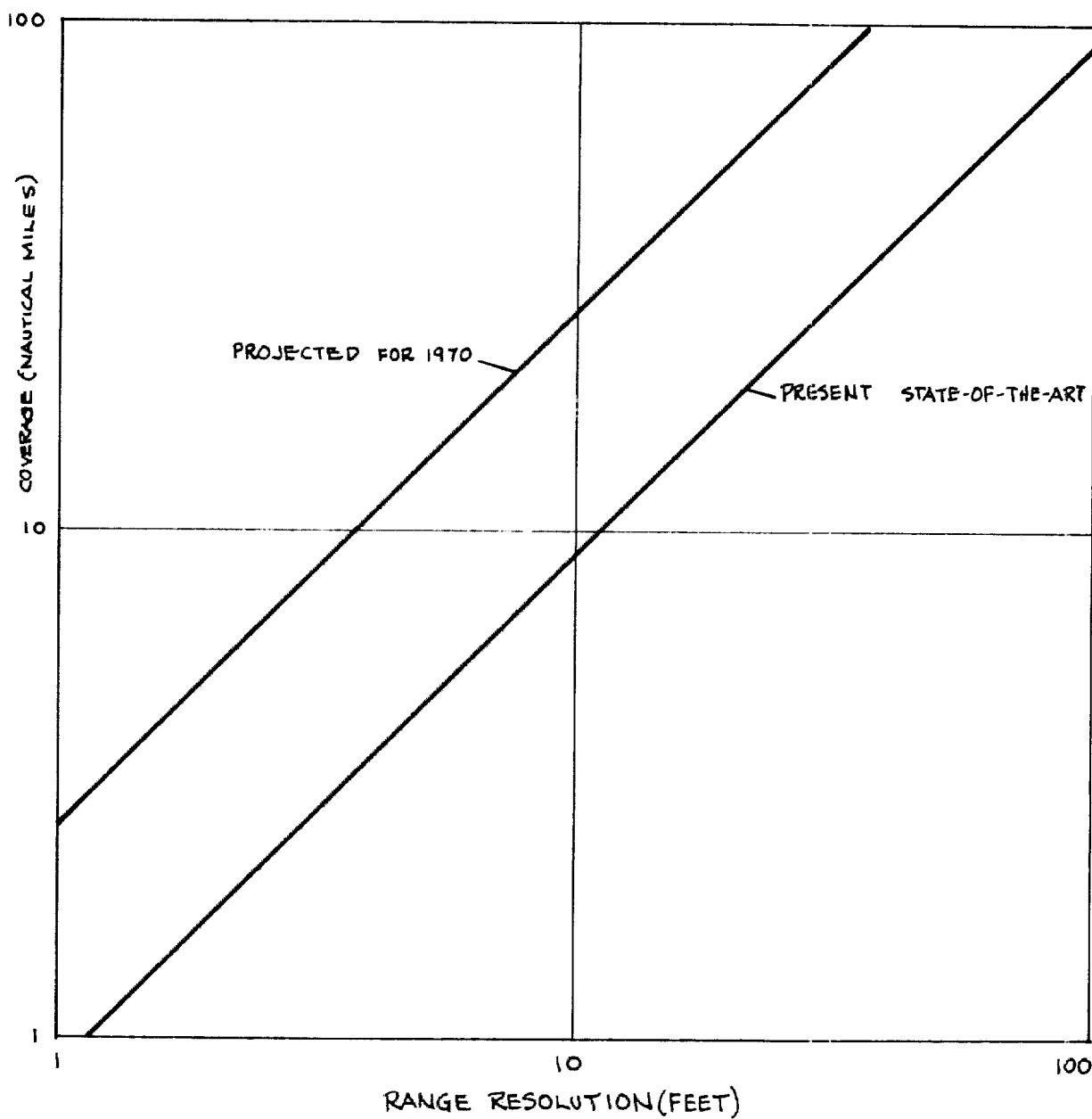

Fig. 4-31 — Total range swath per 100 pounds of recorder.

SPECIAL HANDLING

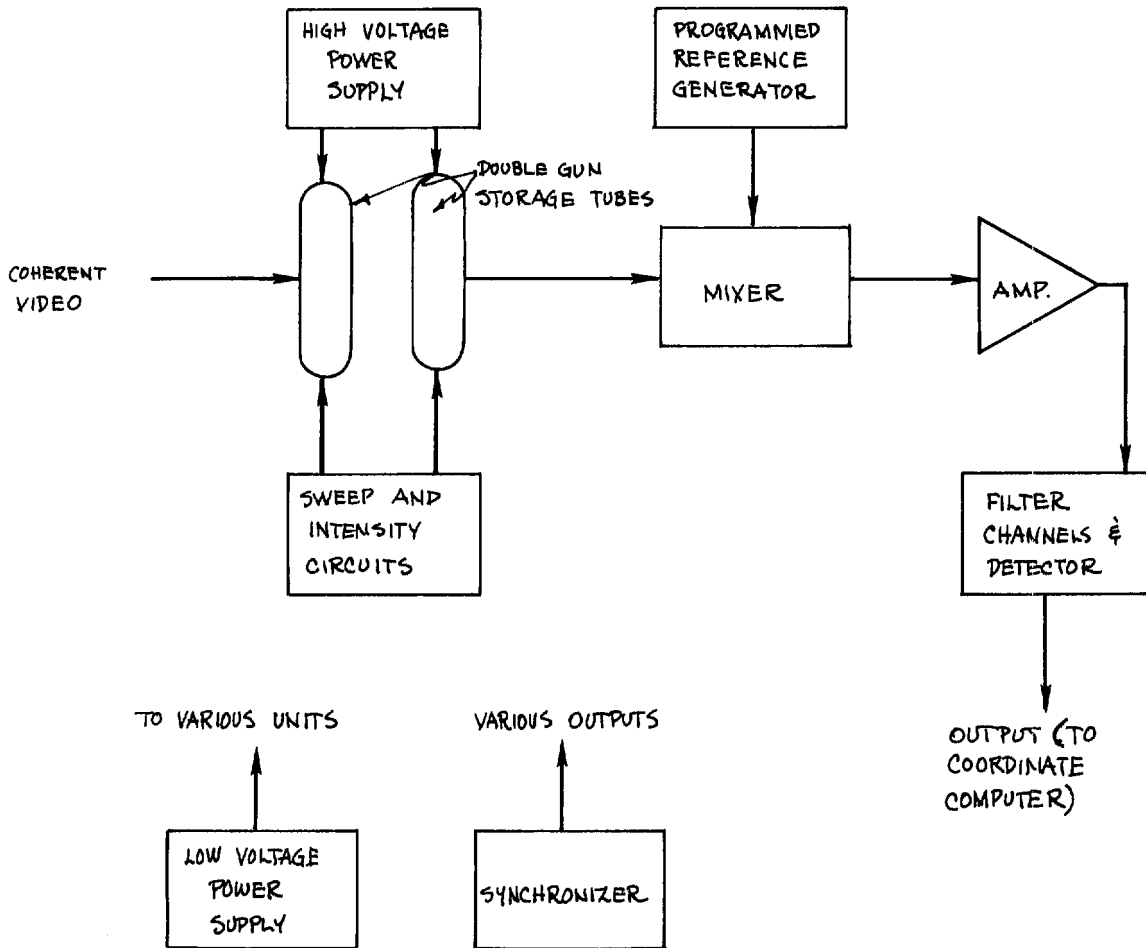

Fig. 4-32 — Real time storage tube MTI processor.

SPECIAL HANDLING

SPECIAL HANDLING

effectively range gates the video data. This data is translated into the proper frequency range for the filters by a programmed mixer. The detection of a signal in one of the filter channels will give the range, azimuth and closing rate of the moving target. This data is put into digital form in the proper format by the coordinate computer. The output of the coordinate computer is then sent via data link and recorded on the keying tape. The estimated weight for such a processor is given in Table 4-6.

There is presently under development by Westinghouse Corporation a dielectric storage belt tube which has approximately four times the range coverage of the storage tube. This corresponds to 4 nautical miles range coverage for 10 foot resolution, or 20 nautical mile range coverage for 50 foot resolution. The block diagram of this processor is shown in Fig. 4-33, and the weight estimates are given in Table 4-7.

4.2.3.4 Weight for Different Configurations

Figure 4-34 compares the weights for the radar configurations which have been discussed in the sections above.

Comparison of Real and Synthetic-Array Radar Mapping Systems — The current real antenna radar reconnaissance mapping systems operate at either X-band (some with moving target indication - MTI) or at K_a -band (without MTI). This latter category is typified by the AN/APD-7 side-looking radar in the RA-5C. This is a "brute force" K_a -band radar built by Westinghouse. The following are approximate characteristics:

- | | |
|-----------------------|--------------------|
| 1. Beamwidth | 0.15° |
| 2. Pulsewidth | 0.1 microseconds |
| 3. Range | 15 nautical miles |
| 4. Range Resolution | 50 feet |
| 5. Azimuth Resolution | (see figure 4-32a) |

The advantages and disadvantages of X-band versus K_a -band for MTI and reconnaissance mapping are summarized in the following table.

SPECIAL HANDLING

Table 4-6 — Weights for Storage Tube Processor

High Voltage Power Supply	75 lbs
2-Double Gun Storage Tubes	60
Programmed Reference Generator	10
Amplifier	5
Mixer	1
Filter Channels	10
Sweep and Intensity Circuits	40
Low Voltage Power Supply	50
Synchronizer	<u>20</u>
TOTAL	271 lbs

Table 4-7 — Weights for Storage Belt Processor

High Voltage Power Supply	75 lbs
Storage Belt Tube	20
Belt Drive System	15
Sweep and Intensity Circuits	25
Mixer	1
Amplifier	5
Filter Channels	10
Programmed Reference Generator	10
Low Voltage Power Supply	50
Synchronizer	<u>20</u>
TOTAL	231 lbs

SPECIAL HANDLING

4-81

SPECIAL HANDLING

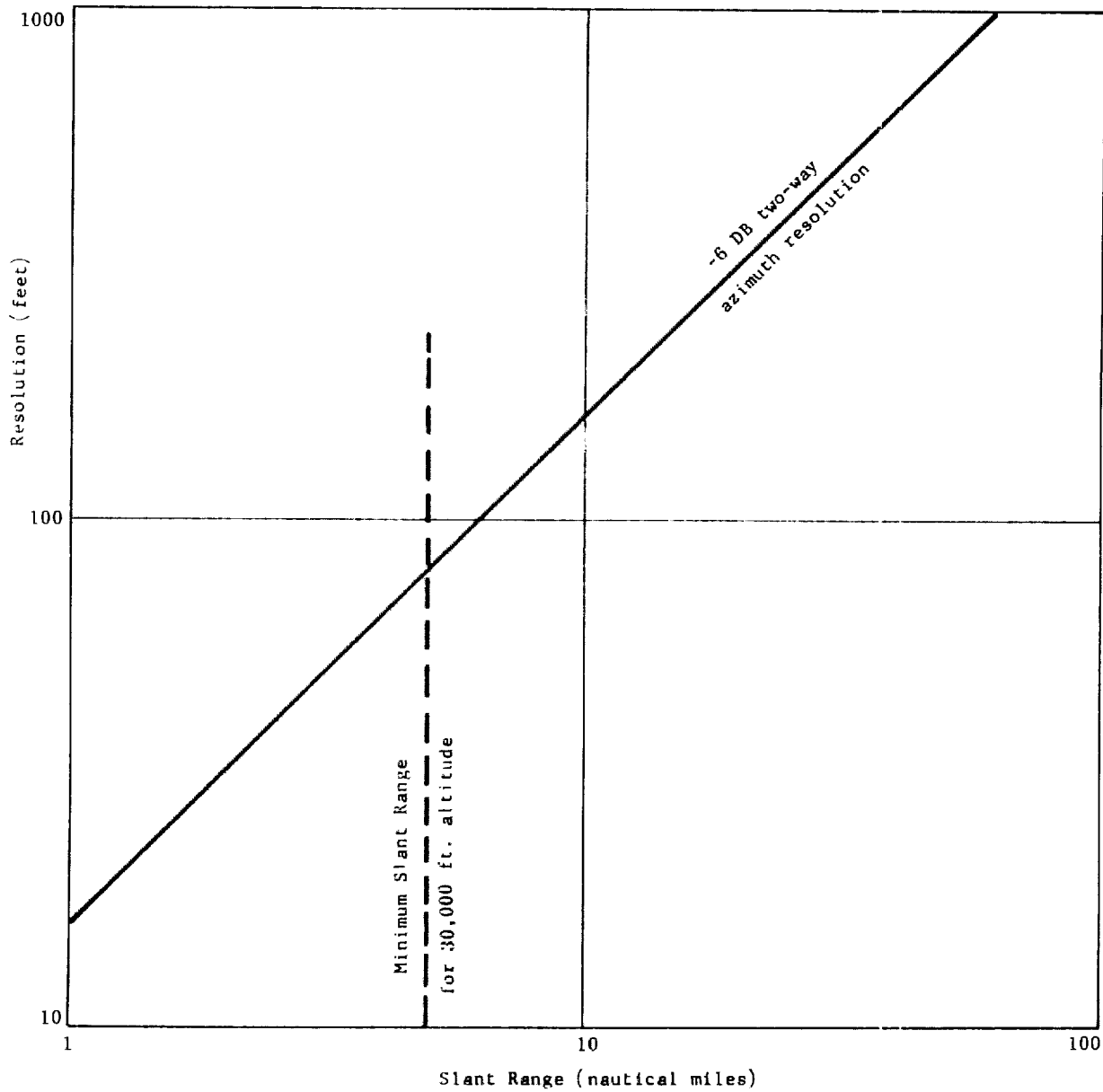

Fig. 4-32(a) — Azimuth resolution of K_a -band real antenna mapping system.

SPECIAL HANDLING

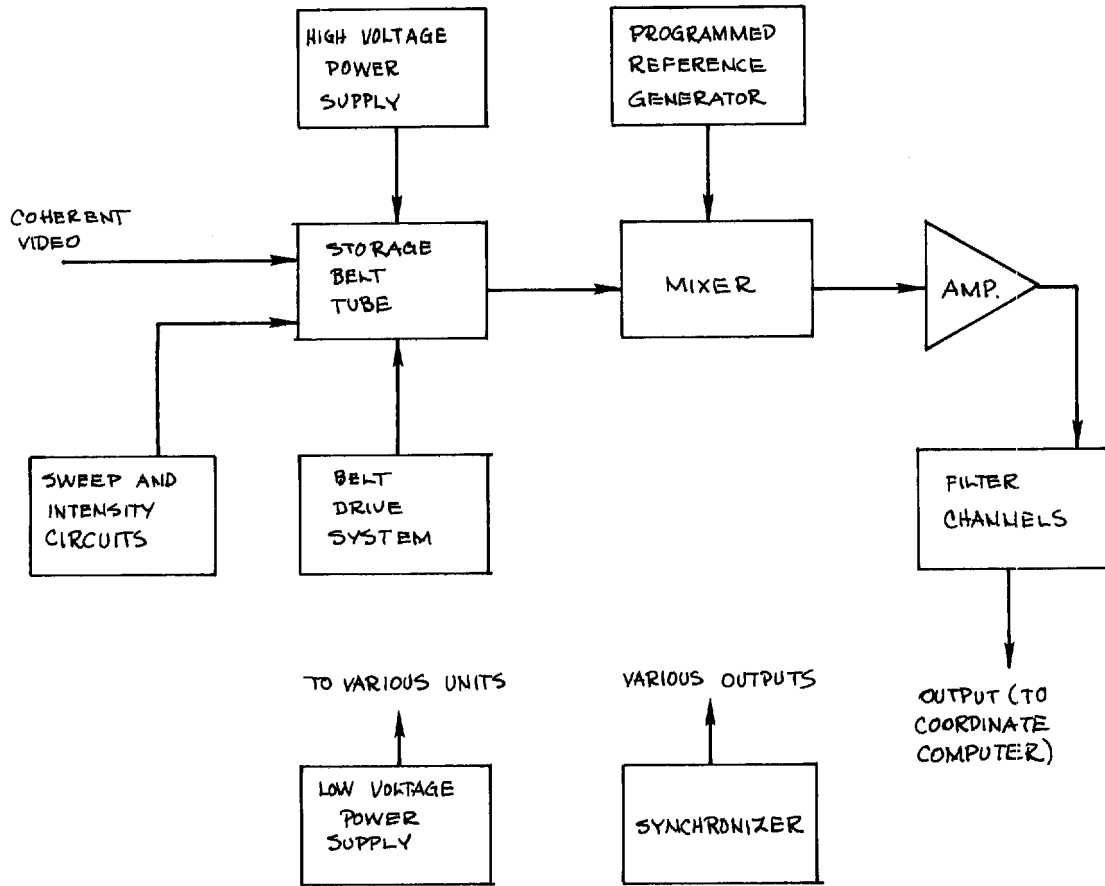

Fig. 4-33 — Real time storage belt processor.

SPECIAL HANDLING

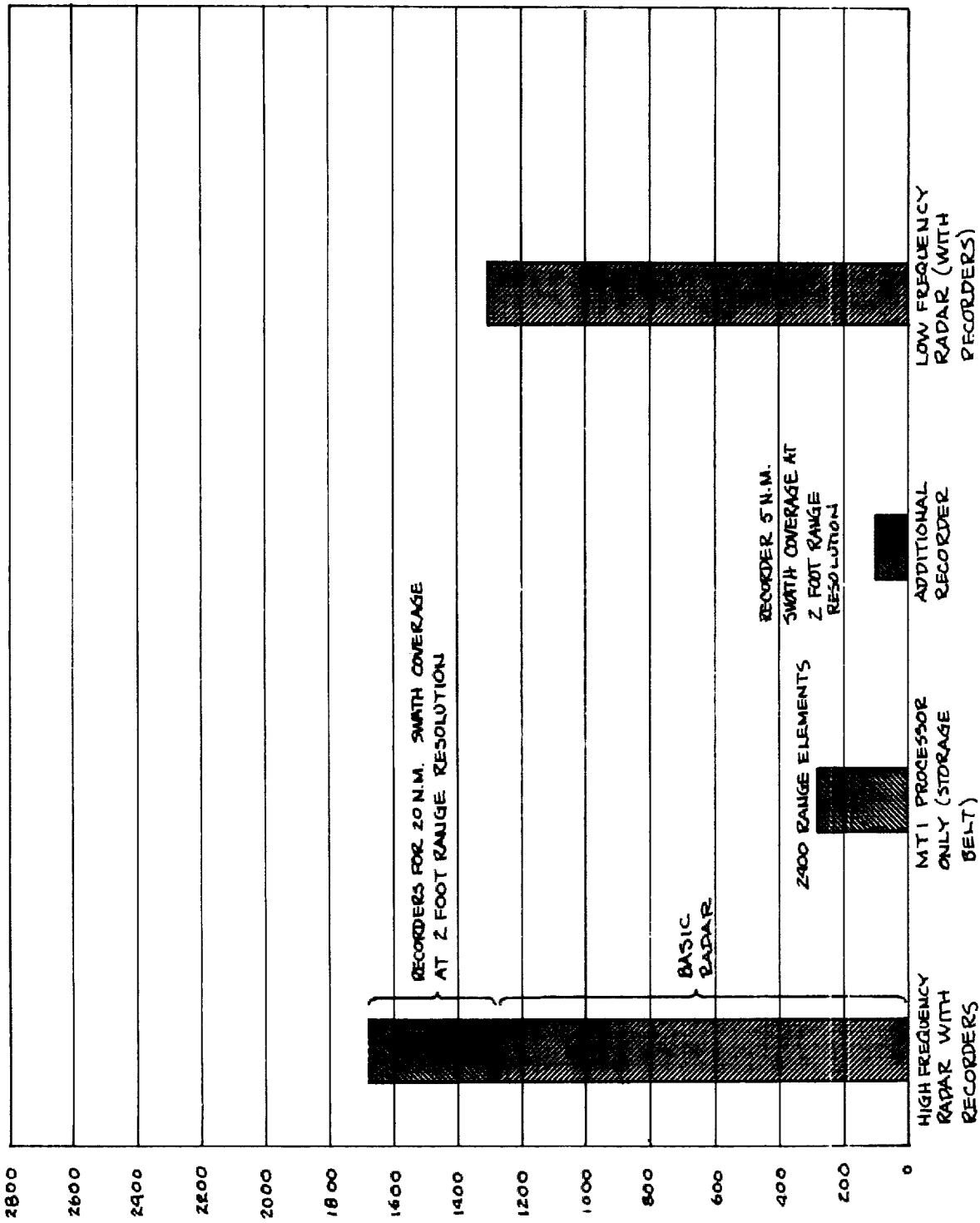

Fig. 4-34 — System weight for different configurations.

SPECIAL HANDLING

X-band versus K_a-band

MTI

1. X-band less affected by weather attenuation and rain backscattering.
2. State-of-the-art in techniques and components for coherent MTI is more advanced at X-band.
3. The ratio of radar power return for vehicle targets to that for natural terrain is greater at X-band and K_a-band.

Conclusion — For MTI purposes alone, X-band is the apparent choice over K_a-band

Real Antenna Radar Reconnaissance Mapping

1. X-band less affected by weather attenuation and rain backscattering.
2. State-of-the-art in components more advanced at X-band but satisfactory at K_a-band.
3. Better contrast between low return surfaces such as concrete, dirt and grass fields at K_a-band.
4. Better azimuth resolution by a factor of 3.5 at K_a-band for a given real antenna length.

Conclusion — For real antenna mapping systems K_a-band is the apparent choice over X-band.

Synthetic Antenna Radar Reconnaissance Mapping

1. X-band less affected by weather attenuation and backscattering.
2. State-of-the-art in techniques and components much more advanced at X-band and may be unsatisfactory at K_a-band.
3. Better contrast between low return surfaces such as concrete, dirt and grass fields at K_a-band.
4. Azimuth resolution at either frequency can be made the same and essentially independent of range.

Conclusion — For synthetic-array radar systems X-band is the apparent choice over K_a-band.

The present X-band MTI systems are not designed to detect relatively slow moving targets such as would be encountered on a tactical battlefield. Therefore different design techniques need to be employed. These design techniques

SPECIAL HANDLING

4-85

SPECIAL HANDLING

are best mechanized by the use of a coherent transmitter and thus the use of a simple magnetron transmitter as is presently used in the K_a -band systems is ruled out.

The factors considered above when applied to the design of a system whose primary purpose is MTI and whose secondary purpose imagery (with perhaps degraded resolution) lead to the following conclusions:

1. The frequency should be X-band.
2. Displaced phase center MTI techniques should be employed.
3. The transmitter power should be high enough to allow 50 nautical miles maximum range performance in the MTI mode.
4. An onboard MTI processor probably should be used employing, for example, the storage tube techniques described in the report.
5. A coherent transmitter is required for reasonable MTI performance.
6. Once an MTI processor and coherent transmitter are used, then a moderate amount of synthetic-array processing can be done on board electronically without the use of any additional equipment.

Therefore the conclusion is that even for the assumptions given, synthetic-array processing would be used.

The general parameters for a system which is used primarily for MTI could be:*

Frequency	X-band
Maximum Range	50 nautical miles
PRF	1 kc
Average Power	500 watts
Range Resolution	25 feet
MTI type	displaced phase center
Squint Angle	45° forward for MTI broadwise for mapping
Range Coverage	2.5 nautical miles for each processor**
Azimuth Resolution (Mapping)	25 feet
Weight (pounds)	
transmitter	250
receivers	100

SPECIAL HANDLING

antenna	350 (both sides)
synchronizer	25
processors	270 (each)
self-test, controls, junction boxes and cables	200

-
- * Note that this is not a recommended system but is used only for illustration.
 - ** Present state-of-the-art. Improvements up to factor of four expected for storage belt system.

SPECIAL HANDLING

4-87

SPECIAL HANDLING

4.2.4 ELINT Sensor

The requirements for a tactical ELINT sensor to be used in the multisensor system are derived from the target signal environment, the tactical mission envelopes and the sensor integration concepts described in Section 4.1.4. These requirements can be summarized as follows:

1. Identification and location of emitters in sectors forward of the aircraft, and in areas covered by the other sensors.
2. Ability to identify emitters and to locate them approximately, in areas outside those covered by other sensors.
3. Real-time signal analysis using onboard computer capability for locating, identifying and filtering emitter targets and threats.
4. Real-time symbolic map-type situation display of the key emitters, continually updated, retained, and presented in a form that is easily assimilated by an operator.
5. Provision for transmitting key emitter identification and location signals to a keying tape for storage, and to a data link for transmission to the surface-based equipment.
6. A permanent record of the "total take" during a mission. This will be used for detailed, long-term analysis of ELINT data on the ship, to up-date the intelligence data base.
7. Capability of functioning properly at ranges to the effective radio horizon at low altitudes, and to 300 nautical miles at high altitudes.
8. Sufficient flexibility to function properly at low or high altitudes (as low as 500 feet and up to 60,000 feet) during reasonable aircraft maneuvers and in very dense, as well as sparse, target emitter environments.
9. A frequency coverage of 60 mcs to 18 gcs. Modular equipment should be designed so that normal frequency coverage can be augmented, when necessary, by special additional ELINT or SIGINT bands.
10. Timely warning of specific threats to the mission from any aspect, as well as an indication of the urgency of the threat, so that action may be taken by the aircraft crew.

SPECIAL HANDLING

Some of these requirements can be met by advanced ELINT systems currently in use. In fact, the only fundamental changes resulting from the multisensor integration are the requirements for:

1. Real-time location and identification of preselected targets.
2. A forward-look capability.
3. Improved short-range and large-depression-angle performance.

The real-time output signals required are the signals to be used for keying of the other sensors, and for the observer's display. Identification and location of 8 to 10 preselected emitter functional types will probably be required. In order to accomplish this task a general-purpose computer will be used.

The requirement for rapid collection and assessment of high priority data indicates a primary region of interest ahead of the aircraft, thus the need for the forward-look capability. This zone, which will encompass approximately 45 degrees in azimuth angle to either side of the aircraft heading, extends from a point below the aircraft to a range near the horizon. It includes the primary targets of interest, and, also, many of the threats to the mission that must be recognized, and possibly avoided. It is in this region that the ELINT system, because of its long range capability, can be of particular value to the multi-sensor system.

The requirement for improved short-range performance of the ELINT sensor stems from the overall system requirement for coordination of the sensor images by keying. At low flight altitudes the undistorted ground coverage of the photo, IR, and radar sensors extends only a few miles on either side of the flight path. If keys from radar emitters located within the same field of view are to be displayed and recorded, the ELINT sensor also must be capable of operating properly at the shorter ranges.

Consideration of the multisensor reconnaissance mission leads to the realization that ELINT system requirements for high altitudes are significantly different than those for low altitudes. The contrast in requirements stems primarily from the differences in processing time available, (the interval between the time when an emitter is first intercepted and the time when it passes under, or abeam, the aircraft) — as well as the significant difference in expected emitter population

SPECIAL HANDLING

4-89

SPECIAL HANDLING

in view (with the resultant order-of-magnitude shift in anticipated pulse density). However, it is reasonable to project the development of a single system that will be compatible with both high and low-altitude missions.

An elementary block diagram of the ELINT sensor to be used with the optimized multisensor is illustrated in Fig.4-35. It consists of antennas and receivers for each frequency band, plus a general-purpose computer to do the real-time analysis. The filtered, real-time output signals from the computer, consisting of the functional identity and location of 8 to 10 emitter types, are supplied to the observer's display, the keying tape and the data link. The raw data output from the computer, consisting of digital pulse words formulated from every emitter pulse received, is stored on the ELINT TAPE for post-flight reduction by the shipboard computer, as is presently done. The a-priori selection of emitter functional types to be identified and located, plus the navigational and timing signals, are fed into the computer to:

1. Establish the emitter keys.
2. Enable target emitters to be located in real-time.

In order to improve the system performance at short-ranges, a variable receiver scan rate, under the control of the computer, will be used. By increasing the scan rate when key emitters are in the field of view, the data rate will be increased, thereby improving location accuracy at short ranges. Reduced receiver dwell time (the period required for the receiver to scan an IF bandwidth) will result, but since key emitters are expected to have relatively high PRF's, the effect of the reduced dwell time will not be serious.

Frequency Range — The operating frequency range of 60 megacycles to 18 gigacycles should be adequate to supply complete ELINT coverage for a number of years to come. In the AN/APQ-61 ELINT system, this frequency range is handled by 12 bands which commence at 30 megacycles, slightly lower than the 60 megacycles recommended above, and terminate at 14.15 gigacycles, slightly less than the 18 megacycles upper limit recommended. Since there appear to be no compelling reasons for altering the frequency band allocations used in that system, the shift in frequency coverage recommended could be accomplished by dropping the

SPECIAL HANDLING

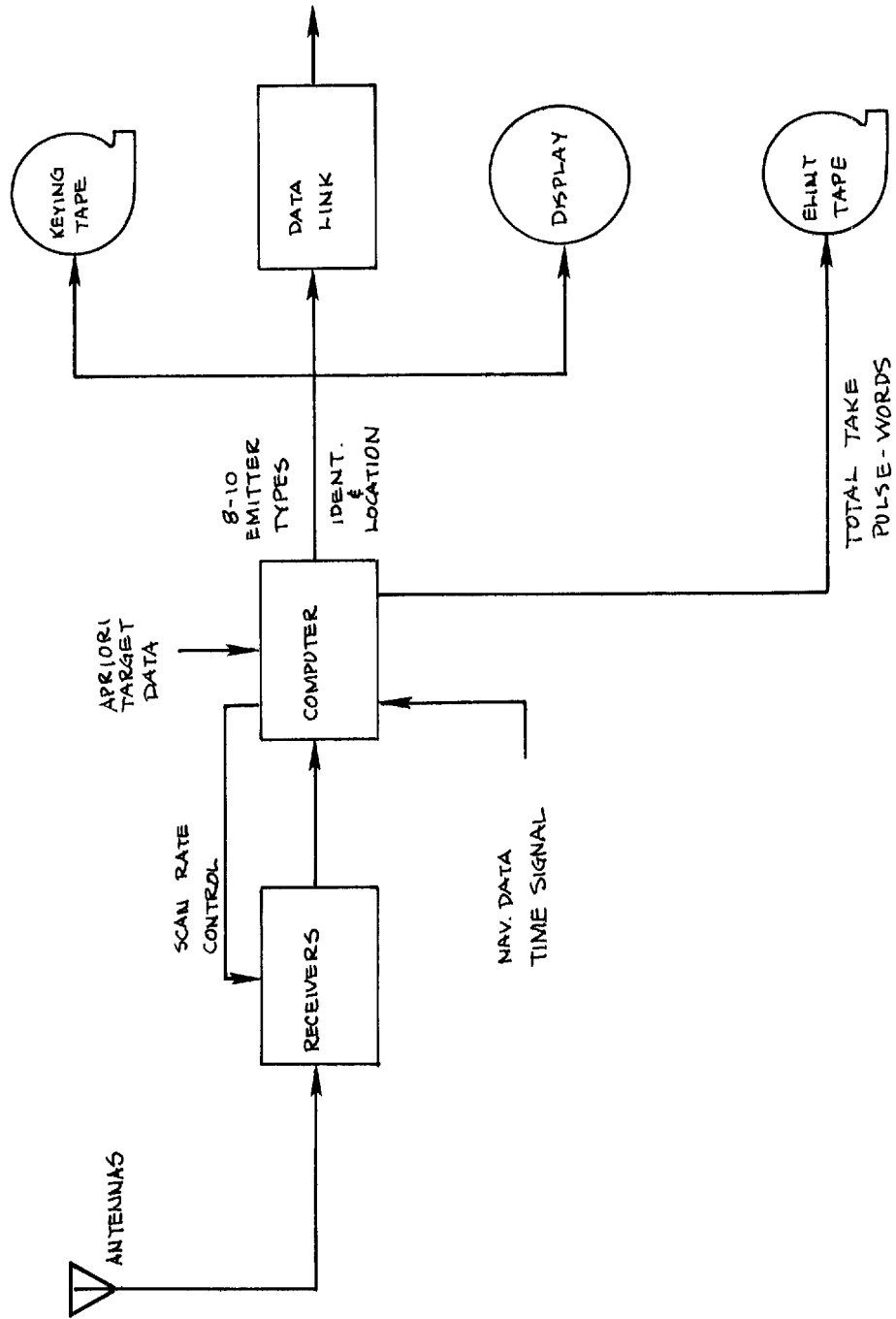

Fig. 4-35 — ELINT subsystem block diagram.

SPECIAL HANDLING

SPECIAL HANDLING

lowest band (30-67 megacycles) and adding one at the top (14,000 - 19,000 gigacycles). The complete frequency coverage would then be 60 - 19,000 megacycles, in 12 overlapping bands. Suggested frequency limits of the bands are contained in Table 4-4 which is given later under the ELINT Receiver characteristics.

Receivers — The ELINT receiving system that looks most promising for the multisensor system provides for the use of scanning receivers at both the high and low altitudes, with control of the scan rate under the supervision of the logic and control subsystem.

The basic receiver electronics for a frequency-determining receiver and a direction-channel receiver are shown in Fig. 4-36. The IF preamplifiers and log IF amplifiers are identical for all channels and all bands. The filter that establishes the IF bandwidth is tailored to the narrowest pulse-radar signal expected in each band. The band coverage and IF bandwidth in each band is also shown in Table 4-7.

The image-phasing mixer provides dynamic image suppression through the use of an amplitude comparator that checks the relative response of the two mixer channels, the signal channel and the image channel. If the signal exceeds the image by more than 6 db, processing of signal data is permitted to proceed. If this criterion is not met, the signal data are not processed. The decision to process is made within 2 usec after the receipt of the pulse.

The frequency range from 60 megacycle to 19 gigacycles is covered in 12 bands. Frequency bandwidths and resolutions have been chosen to optimize signal traffic per band and to provide uniform coverage of the most active Soviet Block radar bands. The bandwidths provide sufficient fidelity for measuring the pulse width of emitters expected in the band.

The band coverage, resolution bandwidth, sensitivities, and expected detection ranges for bands 1 through 12 are shown in Table 4-7. The detection-range calculations include consideration of signal-to-noise ratios required for the degree of angle resolution (beam split) needed for system performance. Sensitivity values represent current state-of-the-art in receiver technology, and certainly can be improved in the next several years.

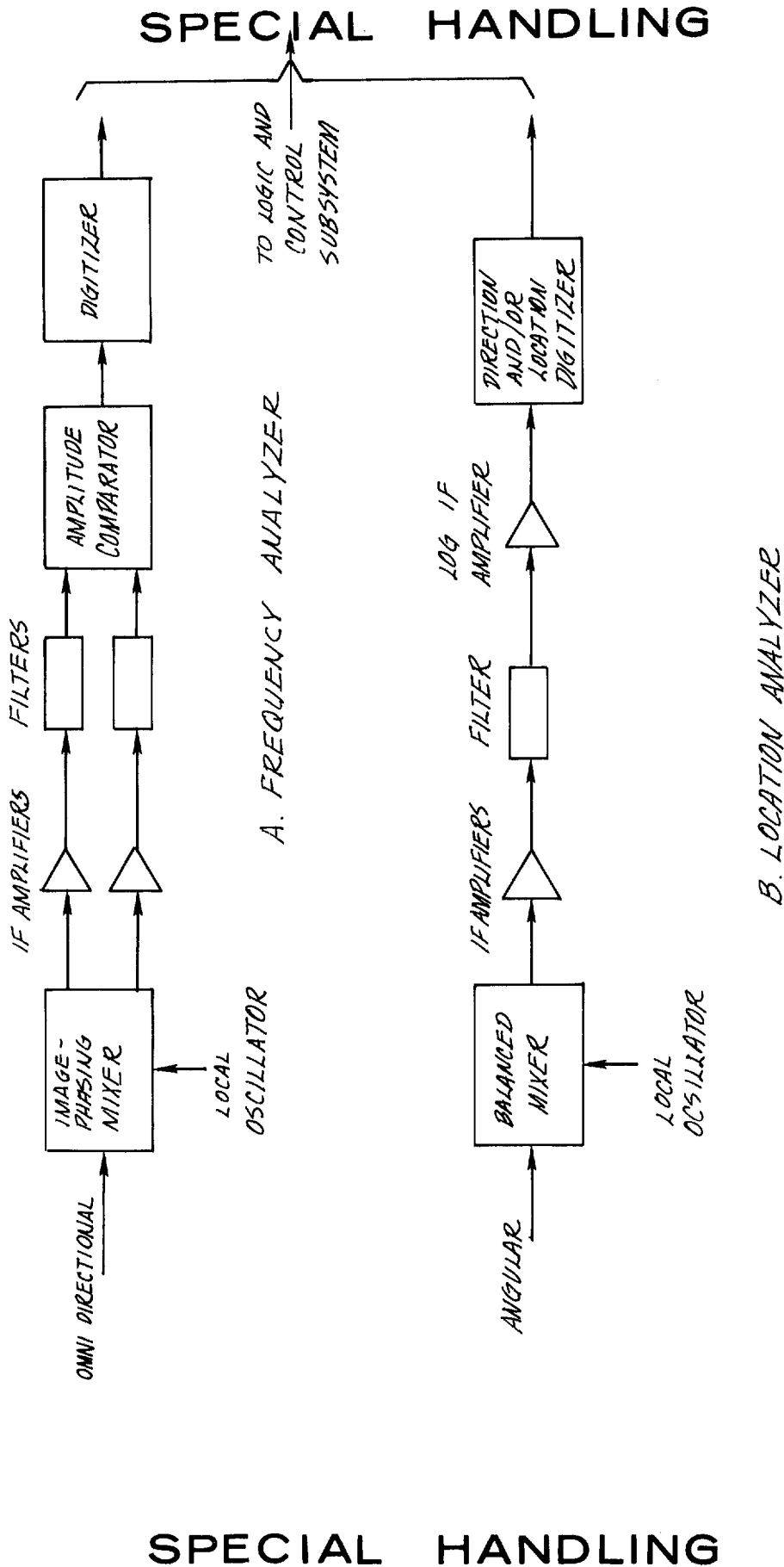

Fig. 4-36 — Basic receiver electronics

SPECIAL HANDLING

SPECIAL HANDLING

TABLE 4-8

RECEIVER CHARACTERISTICS

<u>Band</u>	<u>Frequency Coverage (mc)</u>	<u>IF Bandwidth (mc)</u>	<u>Sensitivity (1) (dbm)</u>	<u>Detection (2) Range (n. miles)</u>
1	60-155	0.3	-65	350+
2	150-268	0.7	-64	350+
3	260-465	1.5	-66	350
4	450-850	1.5	-68	250
5	825-1400	0.7	-70	190
6	1360-2500	1.5	-69	100
7	2470-3740	1.5	-80	220
8	3700-5360	4.0	-78	120
9	5300-7840	8.0	-77	74
10	7400-10,100	8.0	-79	67
11	10,000-14,150	8.0	-77	38
12	14,000-19,000	8.0	-76	25

- NOTES:
- (1) Overall system sensitivity includes antenna gains and system losses.
 - (2) Range calculated at mid-band, assuming target transmitting 250 kw peak at -10 db antenna gain.

SPECIAL HANDLING

The sensitivity and detection range of the receivers at the low altitudes are sufficient to intercept all emitters to line-of-sight at 500 feet altitude. Thus, current receiver technology is compatible with the proposed ELINT system.

Since the direction is determined by the simultaneous comparison (monopulse) of signal amplitudes from several azimuth antennas, several parallel direction receivers are required per band. In addition, a frequency-analyzer channel is used to provide high-resolution reception for time-domain analysis of the received signal. The electronically-tuned local oscillator, mixers, and IF electronics complete a typical receiver band. A receiver band can be packaged in a single line-replaceable unit (LRU) that occupies less than 1.0 cubic feet.

Emitter Location — Operational ELINT sensor systems, for the most part, are using the "fly-by" technique to determine emitter location. One experimental system, however, is using the azimuth-elevation (AZ-EL) technique. Both of these techniques are described in detail in Volume 4, Technology Survey.

Multiple DF cuts in the azimuth plane are used to locate the target as the reconnaissance aircraft flies the base leg of the location triangle. The multiplicity of DF cuts are processed (in many cases in a least-squares program) to statistically improve the location. An alternate approach utilizes bearing-rate information to reduce the location-computing time. In this technique, emitter location is computed by measuring the time required to traverse measured bearing angles to the emitter. Targets can be located in the forward-look sectors, with a trade-off possible between location accuracy and computational time. This trade-off is shown in Fig.4-37. The location accuracy indicated in Fig.4-37 is based on a projected DF system having ± 2 degrees accuracy and 4 degrees quanta. Current operational systems have about ± 3 degrees accuracy and 12 degree quanta.

The time required to obtain the information for a reasonably good fix with the bearing-rate approach varies from a few seconds to several minutes depending on ground speed, target range, and relative bearing of the target when first intercepted.

Although these DF techniques can provide excellent DF homing and location capability on ELINT targets, and are well adapted to strategic reconnaissance missions, the inherent time lags preclude their use as the only location

SPECIAL HANDLING

4-95

SPECIAL HANDLING

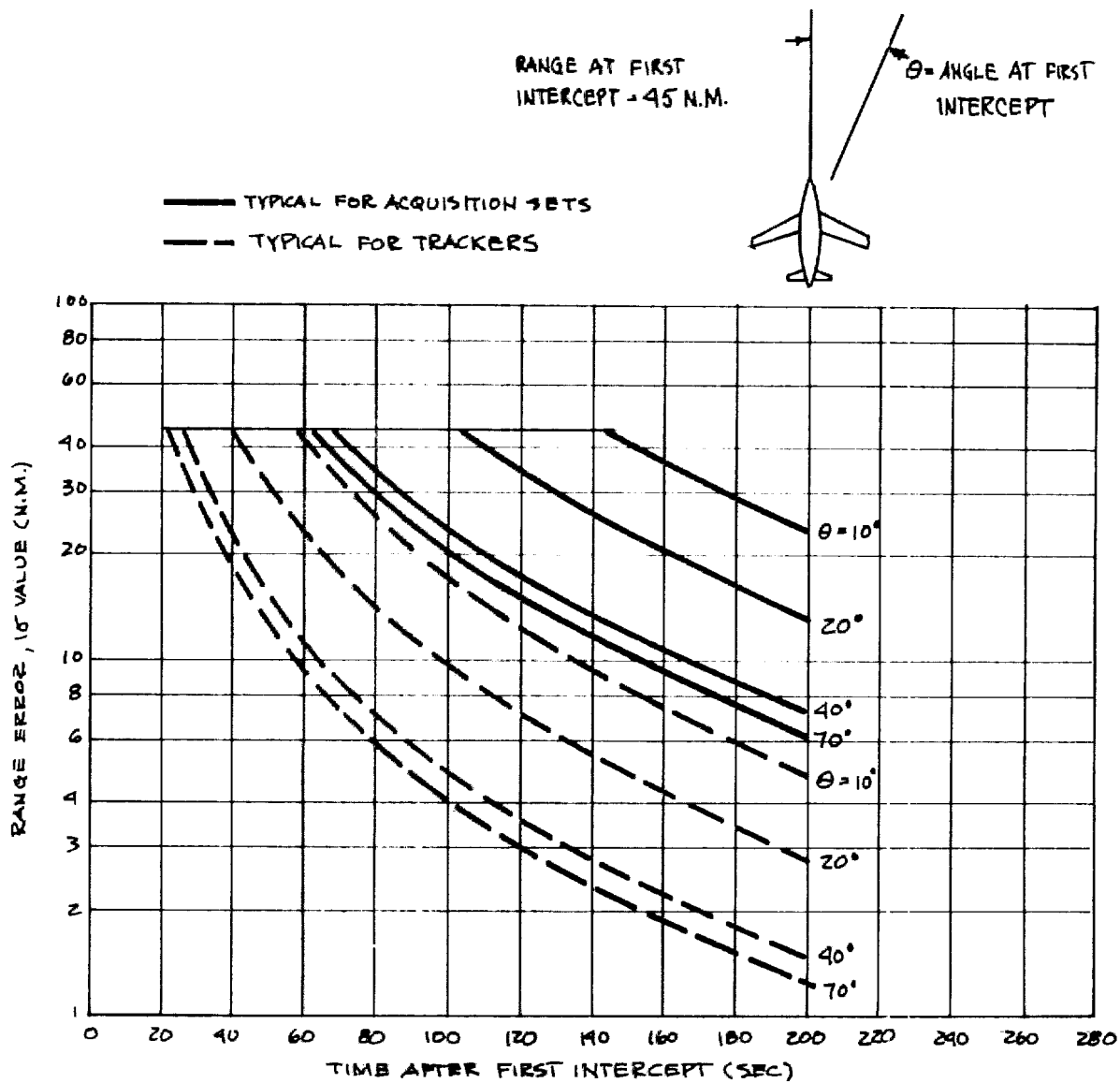

Fig. 4-37 — Range accuracy as a function of time and azimuth

SPECIAL HANDLING

technique in a real-time tactical reconnaissance information system. The location ability of azimuth DF systems also degrades as the relative target bearing approaches about ± 20 degrees from the aircraft heading and is useless dead ahead. The coverage of the bearing-rate system, however, is quite compatible with that of the HRSLR in its MTI mode and good correlation between the MTI and ELINT target keys should occur in this region.

Because target keys must be generated, real-time detection, identification, and display of emitters in the forward and close-in sectors is extremely important. Thus the need for monopulse ELINT location becomes evident. Fortunately, advances in the state-of-the-art in RF systems and compact, general-purpose airborne computers make this step feasible.

Of all the techniques investigated, the method that appears best suited to monopulse location of ELINT targets, and that is compatible with the types of aircraft that may be used, is a forward-looking type of azimuth-elevation system which augments the side coverage provided by the conventional azimuth antenna system. Although a number of antenna types can be used in the azimuth-elevation monopulse system for the forward-looking fill-in antenna, there is an antenna which appears very attractive for this application because of its small size and weight, and extremely broad-band frequency coverage. This antenna is a four-arm multimode spiral. The radiation patterns of its two radiating modes differ in both amplitude and phase such that the theta (θ) angle in a spherical coordinate system can be determined from an amplitude comparison between the sum and difference mode outputs, while the phi (ϕ) angle can be determined by a phase comparison between the two modes. The antenna thus represents a monopulse two-coordinate (two perpendicular angles) radio direction finder, which projects a polar coordinate grid system to the earth as shown in Fig. 4-38.

Because of the oblique intersection of the antenna boresight with the ground plane (in a forward looking system), distortion of the theta-phi contours results when they are projected onto the ground plane. Figure 4-39 shows the projection of the contours for a four-arm spiral mounted at a depression angle of 45 degrees. The figure indicates that if theta is restricted to less than 45 degrees, the ground coverage will extend forward from a point directly beneath the aircraft and will include an azimuth angle (in the ground plane) of greater than ± 20

SPECIAL HANDLING

4-97

SPECIAL HANDLING

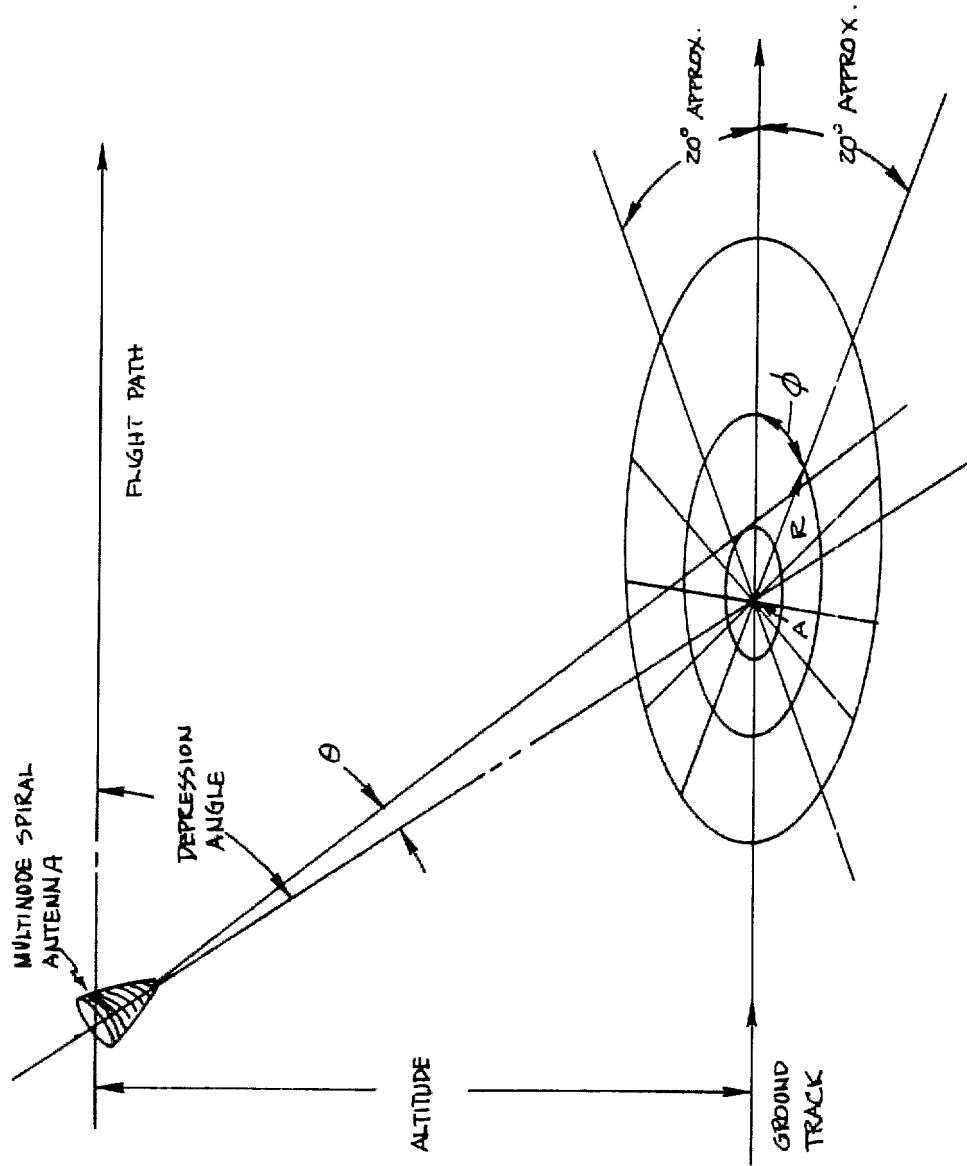

Fig. 4-38 — Forward-looking monopulse antenna (multimode spiral)

SPECIAL HANDLING

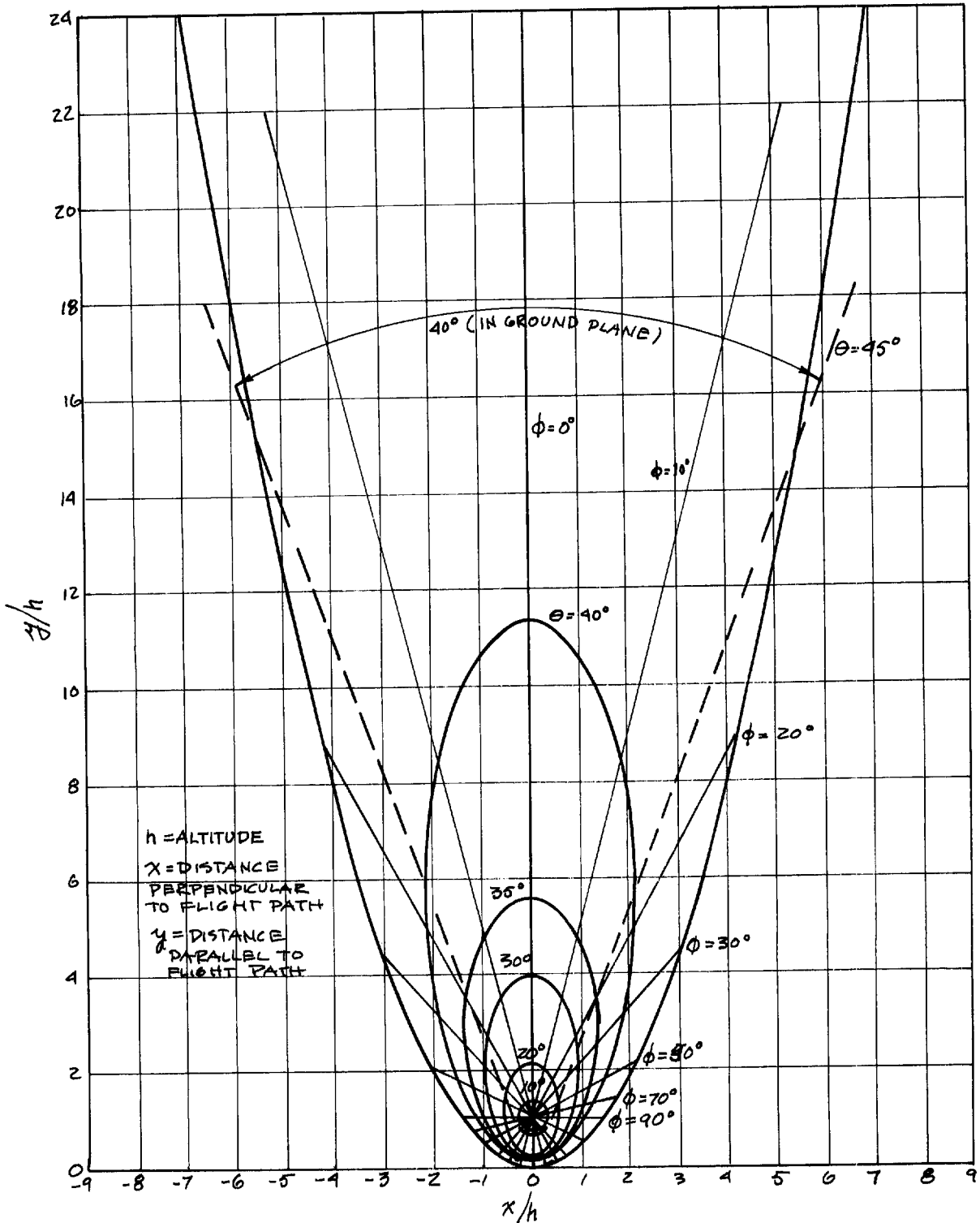

Fig. 4-39 — Projected $\phi - \theta$ grid

SPECIAL HANDLING

SPECIAL HANDLING

degrees for distances up to 15 altitudes. This coverage is compatible with the coverage of other sensors.

The combined coverage of the DF systems is shown in Fig. 4-40. The forward monopulse system covers ± 20 degrees from the aircraft heading. Fly-by coverage is provided from 20 degrees to 140 degrees, with the forward part of this coverage being used for a bearing-rate real-time location. A gap-filler will be required in the aft sector (± 50 degrees) to inhibit traffic in this area.

The system is outlined in flight, location of emitters in the very forward sector, $0^\circ \pm 20^\circ$, will be done by the AZ-EL in real time, to provide an approximate location as quickly as possible for these important targets. As the flight progresses the location accuracy provided by the AZ-EL system will be continuously updated in the computational process. Emitters that best introduce the 20 to 45° sectors will be located more accurately by the bearing-rate DF system, still in near real time, and will provide keys compatible with the hot-spot with the MTI keys provided with the forward-looking IR and HRSLR sensors. Emitters within the 45 to 140° sectors on each side of the aircraft will be processed by the fly-by DF systems to supply keys suitable for the IR photo and HRSLR imagery taken directly below the reconnaissance aircraft. By the time an emitter has passed abeam the aircraft, sufficient statistical sampling of the emitter radiation will have been accomplished by the DF systems in most cases to have achieved accurate emitter location.

Computer — The ELINT system concept described in this study, is a major departure from the design of current operational systems, because of the utilization of an onboard real-time computer to identify and locate preselected emitters. Instead of using a digital programmer to format the pulse words from each emitter, and store them on a magnetic tape, as is done in the AN/ALQ-61 ELINT system, for example, complete processing for a reasonable number of emitter functional types is done continuously in the air. This requires that pulse-train association and location and emitter typing be accomplished in real-time.

The specifications for a general-purpose computer that can fulfill the requirements for such real-time processing are derived from emitter pulse density studies, and from the number of preselected emitter functional types to be handled. The highest pulse density occurs at the high altitudes and is estimated

SPECIAL HANDLING

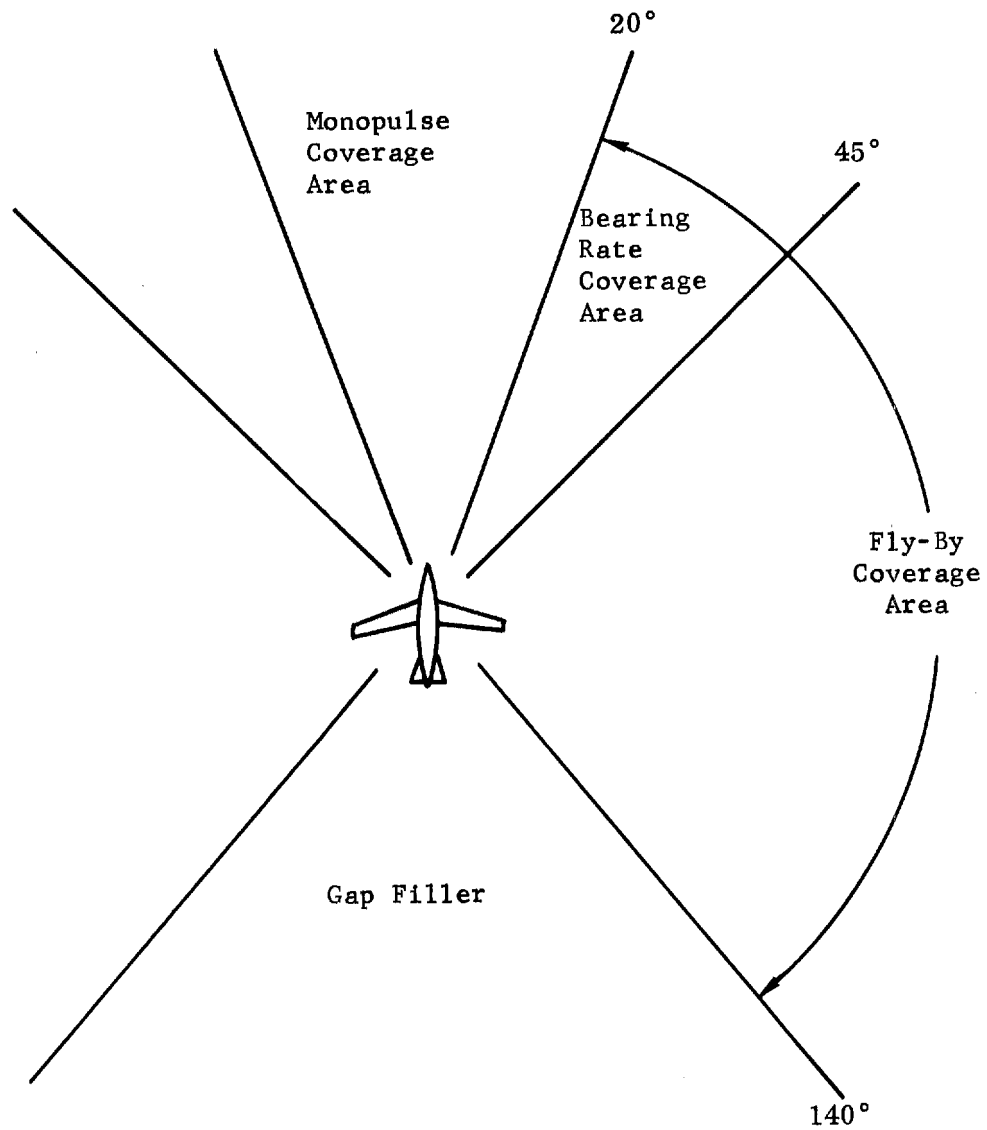

Fig. 4-40 — Coverage diagram of DF systems.

SPECIAL HANDLING

SPECIAL HANDLING

to be approximately 1 by 10^6 pulses per second in view at any one time, with a radar replenishment rate of about 120 per minute (2 per second). At the low altitude this drops off to approximately 3 by 10^5 pulses per second, with a replenishment rate of about 50 per minute (\approx 1 per second).

The output requirements can be estimated from the above replenishment rates (2 per second maximum), and emitter functional types. Having established the input densities and output requirements, the final estimate of computer requirements is made by a detailed analysis of the limiting pulse widths, range of pulse repetition rates, receiver dwell times, interleaving probabilities, and other factors. The results should provide good estimates of the size of the computer memory required, the memory access time, instructional cycling time and other pertinent computer characteristics.

In preparing the designs for advanced real-time airborne ELINT sensors AIL has worked closely with the manufacturers of small airborne digital computers and has detailed data on more than 20 miniature aerospace general-purpose machines. A brief resume of the characteristics of four of these computers is presented in Table 4-9 and the more detailed characteristics of one is given in Table 4-10. The specifications contained in these tables show typical characteristics, and do not endorse any particular computer at this time. Almost all of the computers feature the latest advances in micro-electronic circuits, metallic thin-film memories, and multi-layer photo-etched interconnections.

SPECIAL HANDLING

Table 4-9. Typical Manufacture Aerospace General Purpose Computers (December 1964)

Computer	Status	Word Size (Bits)	Memory		Add* Time (μs)	No. of Instruc.	Input/Output Structure	Vol. (fc) ³	Weight (lbs)	Power (watts)	Software
			Cycle Time	Size DRO NDR0							
Autonetics D26C (Monica C) 1	Proto December 1964	30	6 μs 1 μs Scratch	32 K 0 256 0	6-12	86	Analog or Shaft I/O, No Buffered Digital, 30 Discrete Input and 30 Output	105 (with power sup)	55	192	—
Litton L304 2	Proto December 1964	32 Instr. 16 + Data 32	1.92 μs	32 K 0	7	62	8 Fully Buffered I/O Channels	0.25	26	170	Simulator on 7094
RCA Variable Instruction 3	6-bit mod. operating 30-bit mod. by 3-65	6 to 30	1 to 12 μs	5 Banks of 32 K 5 Banks of 32 K Max = 164 K	2 Memory Cycles	Unlimited (Micro-Program)	Under Micro-Program Cont. Fully Buffered	0.4 (2 each 0.2)	—	250 with P/S	No Simulator Possible. Depends on Desired Instruction Repetition.
UNIVAC 1824 4	In Limited Production	16 Instr. 24 Data	4 μs	1024 Max 18 K Max	8	32	Not Buffered	0.21	21	110	Assembler on 490 and 1206

*Max. Memory Size Without Redesign.

*Includes Memory Access.

SPECIAL FEATURES

1. Seven index registers, repeat mode instructions, 15 block data instruct., indirect addressing.
2. Eight addressable 16-bit process registers for each of 64 program interrupt levels for a total of 512 registers, each register is multi-purpose and may be used as accum.-index register - or for list processing, capable of comparing A:B ± Δ B in one instruction, small MIL MAG tape available.
3. Micro program interprets OP code of instruct. stored in main mem., capable of true simultaneous multi-program operation, example: 5 - 1 hour programs run in 1 hour with 5 memory banks.
4. Designed primarily as a ballistic missile guidance computer.

SPECIAL HANDLING

SPECIAL HANDLING

Table 4-10 Miniature Airborne Computer - Typical Characteristics

Physical

Size	0.21 cubic foot (outside dimension including cooling fins)
Weight	21 pounds
Power	67.7 watts

Operational

Type	High-speed, general-purpose, stored-program, binary, parallel
Command Structure	Single address, 40 instructions, three index registers
Word Length	16-bit, instruction and 24-bit data
Memory	Metallic thin film, Random access
Nondestructive readout	4096 24-bit words holding 6144 16-bit instructions, electronically alterably, BICORE film expandable to 14, 336 24-bit words
Destructive readout	512 24-bit words; expandable to 1024 words
Maximum Short-Instruction Operation	125,000 instructions/second
Guidance Program Operation	65,000 instructions/second
Instruction Execution Time	
Single Precision Add, Subtract	8 microseconds (24-bit operand)
Double Precision Add, Subtract	12 microseconds (48-bit operand)
Multiply	40-72 microseconds (48-bit product)
Divide	104 microsecond (24-bit quotient)
Square Root	192 microsecond (24-bit root)
Shift	8 + 1 - 1/3N microsecond (48-bit word)
Scale (or normalize)	8 + 1 - 1/3N microsecond (48-bit word)

SPECIAL HANDLING

4-105

SPECIAL HANDLING

4.3 SENSOR OPERATING PROCEDURES

4.3.1 Photographic Sensors

The sensor complement has been described for each of the basic systems suggested for the multisensor mission. With the variety of equipment now available to the observer, the use of those systems can be described.

The operator should be given the responsibility for deciding on the correct selection of sensors on a sortie. The AIO will have set up a flight path and target list which the sortie is responsible for following. Under normal circumstances that flight plan should not be deviated from except in emergency. The problem of "targets of opportunity" will be handled by acquiring data on those which are in "view" with no changes in the flight plan. The systems fields of view are shown in composite in Fig. 4-41. It is felt that the AIO is responsible for the data collection and priority assignment of targets, and deviation from an assignment must be at his discretion. He is furnished with crew observations and fragmentary automatically classified information which may justify a change, plus a real time IR or SLR image and the "key" data by the system, so that his scope of action now includes redirection of a sortie based on a correlated need.

The sensor package is so conceived that the maximum useful coverage area is included under normal operating conditions. The operator function in a target area or between targets will be to assess the local atmospheric and flight parameters, and select and control those sensors which can gather useful information. To aid in this task, the observer will be provided with a display system which covers the area surrounding the aircraft to the limits of the sensor fields of view. The display will have the latest order of battle status map as base information, with the aircraft position indicated on it so that key inputs can be instantly noted as new or old identifications. The keys refer to the threshold indications of IR hot spots, SLR moving target indications, and reflective targets, and identified ELINT targets. These keys will be properly geographically located on the display. The operator will also have the option of displaying the vertical or forward IR imagery in real time for gross analysis or navigation purposes.

SPECIAL HANDLING

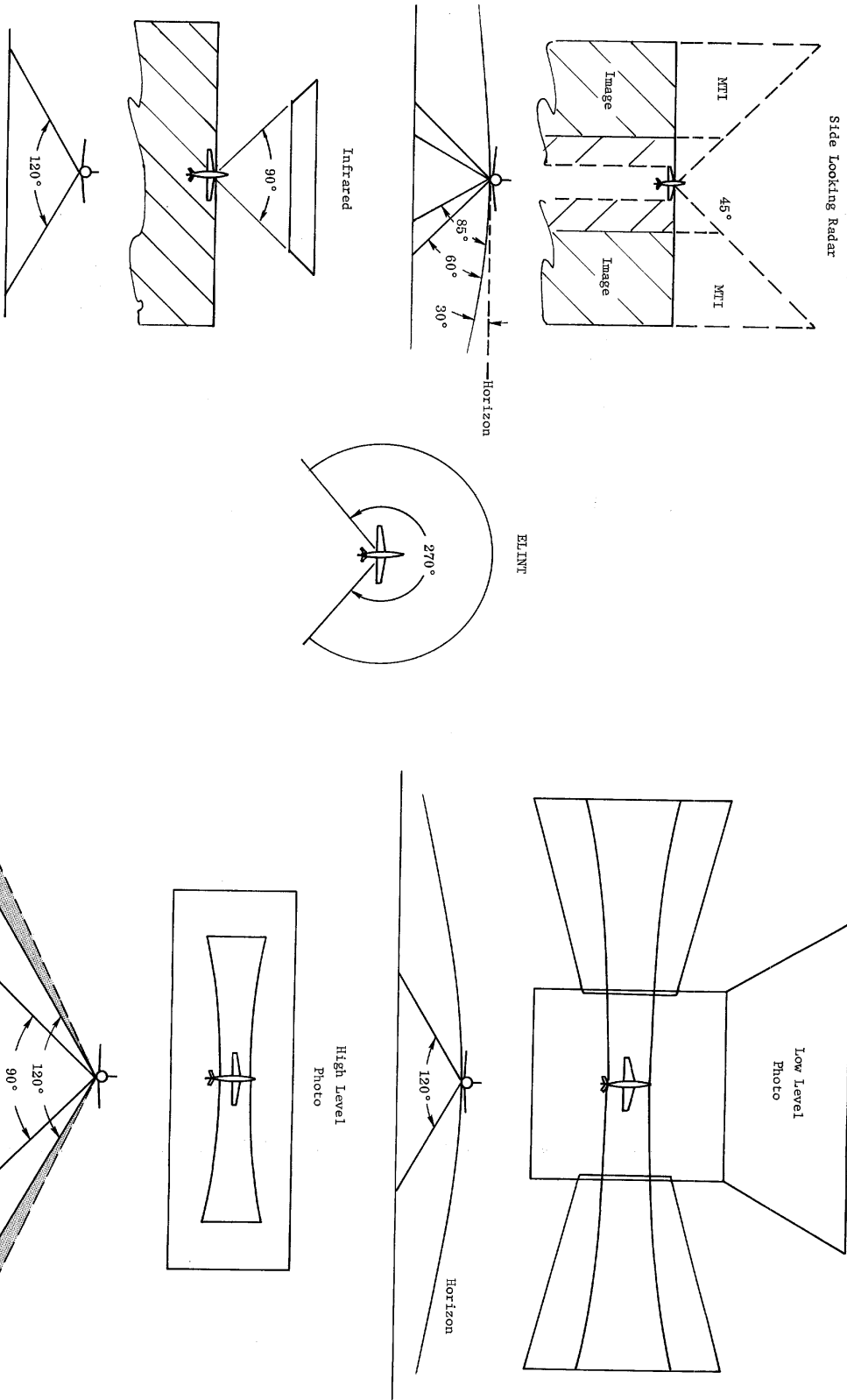

Fig. 4-41 - Multisensor components fields of view.

SPECIAL HANDLING

SPECIAL HANDLING

It is intended that the data link in the aircraft will relay the display information plus operator comments via keyboard to the priority analyst associated with the air intelligence officer. The priority analyst then will have a real time IR or SLR image, as well as the key and observer reports to guide the analysis team in preparation for the return of the reconnaissance data itself. The problem of display to the observer has been extensively studied and the conclusions are that the observer cannot perform sufficiently detailed analysis. However, he can exercise considerable judgment on fleeting targets, and do a gross determination of target identification which can be very valuable. The gating factor on his performance is the human data rate, which is limited to 5-10 bits/second. By providing a reporting keyboard, and key information on a display, the sensor system reduces the data display to the operator to a level where he can utilize his full capability without saturation. It will be necessary to provide imagery at times for navigation or analysis, and the study shows that the IR input, already electronic and not as weather limited as photography, is the best choice for display.

Especially at low altitude the operator would be faced with an impossible task if required to view the very rapidly passing terrain in real time. The features and discussion of the display system are discussed in detail in the following section.

With the display available in real time, the operator function is greatly eased for he can determine when a "target of opportunity" which is beyond the scope of the flight plan is in view. He is then able at his discretion to activate the photographic sensors, which will be the limited collection sensor. It is suggested that the IR, SLR and ELINT records should be maintained for the entire sortie with their reduced resolution capability. The high resolution IR, and the photographic systems gather so much information that their use should be delegated to the portion of the sortie of assigned and opportune value. It is assumed that the photographic records are the prime records when available; however, the system is designed to depend on the best resolution record that is obtained. For example, under darkness or extreme weather conditions, the IR and SLR, in that order, may represent the best or prime record.

SPECIAL HANDLING

4-109

SPECIAL HANDLING

It will be the function of the operator/observer to control and checkout the operation of the sensors. Each device will have a control panel and checkout panel when required. There will also be a master selective/operation panel for the entire system close to the display system.

4.3.2 Infrared Sensors

During a mission, the operator will be able to control the infrared sensor only insofar as he may select an on, standby, or off mode plus semi-automatic equipment checkout. If operation considerations require it, he may in addition be given manual override on the scan rate and sensor gain controls. Normally these would be automatically adjusted by a V/h sensor and automatic gain control circuitry.

A synthetic display will be provided the observer which will include a mission map or photograph plus OB data, and keying information from the infrared, SLR and ELINT sensors. The operator may select the thresholding levels for the IR key data and the effective field of view of the IR sensor for keying purposes. This does not affect the field of view of the raw data being recorded.

The key information, in addition to appearing on the sensor records and on the synthetic display, may also be recorded in a temporary high priority data store. This information may be transmitted directly back to the carrier, or alternatively, to a user at the battle line. This allows transmission of artillery direct information, or indication of areas of high activity with a minimum delay time and minimum interpretation requirements. Correlative data from the SLR and ELINT sensors is also transmitted to provide additional confidence. Because of the relatively infrequent occurrence of high priority key data, a narrow band width communication link may be employed with extensive coding to prevent jamming.

The observer may elect to display the IR imagery data directly rather than the synthetic display. The mission map and OB data will be retained and the IR imagery will be in essentially real time so that the observer may compare the map and the imagery to aid navigation and/or target recognition.

SPECIAL HANDLING

4.3.3 High Resolution Side Looking Radar (HRSLR) Sensor

Radar sensor operating parameters can be divided as follows:

1. Preflight
2. Inflight
3. Post-flight

These phases can, in turn, be divided into systems check-out, mode selection, parameter selection, and data handling procedures. Each phase is discussed below.

4.3.3.1 Preflight

The preflight check-out procedure includes sequential tests utilizing self-test features of the radar in conjunction with the airborne computer and observer display. A synthetic signal generator will be used to give an output on the observer display which will indicate operation of the basic radar, MTI processor, and radar imagery raw data scanner. These three outputs will serve as a go no-go subsystem test. As part of the inertial system gyro erection and alignment, the inertial inputs for motion compensation can be checked.

If the system is configured to have additional modules (for example, additional recorders or a low frequency radar pod), then these modules are installed when missions and weather justify their use. Radar parameters and recorder switching sequencing can be stored along with navigation data in the computer or can be included in the briefing material of the observer depending upon whether automatic or manual techniques are employed.

4.3.3.2 Inflight

After take-off and before entering the initial target area, the radar system is turned on and sequenced through the warm-up cycle. The observer decides when to transmit based on the mission requirements. Transmitting periods are minimized to avoid alerting enemy defenses. For each target area, the recorder and MTI processor range segments are chosen. The observer can

SPECIAL HANDLING

4-111

SPECIAL HANDLING

also select the MTI processor output for the observer display. A priority range segment to be recorded for output scanning and telemetry can also be selected. At the time range segments are selected, other parameter changes such as antenna pointing, PRF, and one or two side operations of the aircraft are also chosen.

4.3.3.3 Post-flight

Upon aircraft return to the carrier, the recorder raw data film recorders and the MTI keying data (on the data key and navigation tapes) are removed from the aircraft and taken to the data analysis center aboard ship. The keying data can be immediately used by the priority analyst or interpreter. The raw data films are photoprocessed and then output image maps are made in the ship-board optical correlator. These output images are then photo-processed and used for image interpretation and change detection. This sequence is maintained as a higher resolution image back-up to the SLR data which may have been transmitted, and already be in analysis when the aircraft SLR imagery is available.

4.3.4 ELINT Sensor

4.3.4.1 Mission Planning and Briefing

The multisensor reconnaissance mission is designed to meet the data requirements of the carrier air intelligence officer. Depending on the type of data needed, the terrain to be overflown, the known threats to be encountered, and other factors, the air intelligence officer prescribes the flight parameters, the target areas, and the sensor application. All key flying and non-flying personnel receive briefings and instructional material to coordinate the preparations and assure a successful flight.

4.3.4.2 Data Loading

In addition to the information required by the air crew, data must be loaded into the ELINT system and its airborne computer, depending on the type of mission and tactics to be employed. Some of these data are as follows:

SPECIAL HANDLING

1. Special Signal Table - parameters describing emitters of special interest, known to be in the environment.
2. Computer Instructions - stored program for the computer - includes processing modes, dwell times, self-check routine, etc.
3. Radar order of battle along the route.

The above information is loaded into the ELINT computer by means of magnetic tape using a portable magnetic tape reader. The radar order of battle along the route is automatically prepared by the central data processor on the carrier, utilizing the planned route and altitude and the complete ROB as input data.

4.3.4.3 Preflight Checkout

A combination of Aerospace Ground Equipment (AGE) and built-in test equipment is required to ensure that the operational requirements of the ELINT system will be met.

For flight-line testing, to determine flight readiness, the ELINT sensor system will contain semi-automatic, built-in test facilities. Also, facilities will be provided to prepare the system for specific mission objectives. To supplement the fault-isolating capability of the built-in equipment, a minimum of portable flight-line AGE is required.

Built-in test facilities are required to perform, on the flight line, a rapid qualitative, self-assessment of the state of readiness of the ELINT system to perform its assigned task. These facilities will provide for a rapid, semi-qualitative check of almost all the functions of the system including all channels of all receivers. The test time for performing a semi-automatic functional checkout is estimated to be 10 minutes. For possible preflight, an abbreviated version of the complete test, limited to particular bands and word types, can be made in significantly less time. In addition, by the use of the ELINT airborne computer for programming and data analysis, the complete self-test time can be considerably reduced. However, unless the possible savings in test time warrant the additional expense and complexity of automating completely, it is felt that the semi-automatic approach to testing is adequate.

SPECIAL HANDLING

4-113

SPECIAL HANDLING

The preflight check of the ELINT subsystem consists of injecting simulated emitter signals into the system from broad-band interference generators mounted in the vicinity of the antennas and, at the same time feeding a simulated navigation output to the computer. The airborne and carrier displays are energized and a short simulated flight is flown, using cable for link transmission. To save time, only the factors most critical to the success of the specific mission are preflighted.

4.3.4.4 Inflight Check

Depending on the extent of preflight testing, some cursory checks may be desirable after take-off. The carrier itself provides an excellent target for MTI and infrared checkout. In addition, unless strict electronic silence is being maintained, it will provide one or more emissions for the airborne ELINT subsystem. Consequently, it would be profitable to energize the multisensor system immediately after take-off and if radio transmission is authorized, to transmit sample data on low power to the carrier. Obviously, if minimum operation for the mission is not obtained at this point, the aircraft should be immediately recalled.

4.3.4.5 Reconnaissance Run

The observer readies for the run by turning on his passive sensors and noting the displays. When the reconnaissance area is reached, the recording equipment is energized and keying data are available for the narrow band link. At low altitudes, the wide band data link is out of line of sight from the carrier, and hence is not used until the aircraft climbs out of the reconnaissance run.

The observer monitors his multisensor display and used his observer push buttons to interject his own keys, and otherwise follow the status of the mission. He also maintains a watch for threats, both visually and on the displays and informs the pilot accordingly, using his ECM if required. In addition, he may perform navigation fixes by map-matching the terrain overlay with the IR map image, or by visual observation of the terrain.

SPECIAL HANDLING

The observer exercises his judgment when required, by overriding the computer to freeze images, to set display scale factors, to give transmission priority to a particular target, to shut down a poorly performing sensor, and to accomplish a host of other details.

4.3.4.6 Wideband Data Transmission

The resumption of line-of-sight with the carrier can be detected by acquisition of the reconnaissance aircraft on the carrier radar, computation from navigational data, monitoring a signal transmitted from the carrier, etc. When line-of-sight is indicated, the IR, ELINT and HRSLR data take is transmitted to the carrier, giving the air intelligence officer a lead on the data processing and evaluation task which must be performed before the follow-up mission is launched.

4.3.4.7 Return to Carrier

On the return flight to the carrier, the airborne computer could be used to process the pulse word data which was not reduced to keying symbols. Any additional keys generated during this operation can be immediately transmitted on the narrow band link. It may be profitable to widen the list for this phase of operation to include more than the original 20 priority emitters.

On request, portions of the narrow and wideband transmissions which were not satisfactorily received by the carrier are re-transmitted. It is advisable to secure a complete transfer of data to the carrier as quickly as possible to hedge against the possibility of loss of the aircraft on the return flight.

4.3.4.8 Post-Flight Operations

The data delivered by the aircraft after landing on the carrier consist of:

1. Photo-reconnaissance film (already processed).
2. IR map and tape (W).
3. ELINT pulse word tape.
4. Keying tape (N) (W).
5. HRSLR film already processed (W).

SPECIAL HANDLING

4-115

SPECIAL HANDLING

An (N) or (W) following a data item means that the data has already been transmitted via the narrow band or wide band link, respectively.

The data cannisters are immediately unloaded by carrier personnel and rushed into the appropriate processing and display areas, while the flight crew is debriefed for intelligence and equipment performance information.

SPECIAL HANDLING

4.4 OBSERVER DISPLAY AND CONTROL OPERATIONS

To provide tactical reconnaissance under all weather conditions, in day or night flight, it is required to use multisensor reconnaissance systems that provide target information from infrared, radar, photo, and ELINT sensors. Although each of these sensors provides unique information that can serve to supplement an observer's intelligence evaluation, the variety and quantity of information could easily overload, or degrade, the observer's capacity to use it, if it were indiscriminately displayed.

Suggestions for presenting the different forms of data range from a separate display for each sensor, to some combination or superposition of all available sensors. A more realistic technique would fall somewhere between these two extremes.

In the multisensor system recommended in this study, a "situation" type of real-time display has been advocated as a powerful method of integrating the reconnaissance observer into the multisensor data management loop. As pointed out earlier in this study, the aircraft observer is a "fifth sensor" with unique capabilities which should be exploited in optimizing the overall intelligence system. Certainly his capabilities for monitoring, evaluating and applying judgment to a rapidly changing set of stimuli are unmatched by any computer or machine. To ignore these capabilities would be to remove from the multisensor system a valuable source of dynamic intelligence.

It is imperative, therefore, to design the observer's real-time situation display so that its output matches his data handling capability. Complicated displays, rapidly changing data, fancy overlays, and the excessive use of controls to be actuated, must be minimized. This is the justification for the elementary display recommended herein--sensor activity "keys", against map-type image backgrounds when desired.

SPECIAL HANDLING

4-117

SPECIAL HANDLING

The multisensor information available for display is likely to be more than the observer can use or interpret at certain phases of the mission. Consequently, some degree of filtering before presentation is essential. Any filtered reconnaissance data should be classified and coded with respect to target signatures and threats to the aircraft.

ELINT data lends itself readily to such categorizing and coding, as do the HRSLR and IR returns which can be coded according to moving target or heat intensity patterns. When scanning techniques can be used to intercept pictorial information, as in the case of the IR, identifiable terrain features or desired target signatures could also be displayed. The coding should clearly differentiate targets from one another, as well as from threats, and give some indication of the level of priority for each.

Before examining techniques for displaying multisensor information, it would be of value to consider briefly the problems of display for each available sensor. The manner in which reconnaissance data are to be presented is greatly influenced by the nature of the energy source and the sensor itself. For example, the photo, IR and radar mapping images provide a "literal" pictorial representation of a ground target, but IR hot spots, radar MTI and ELINT emitters constitute only a "symbolic" relation to the real target. The transfer of target appearance to luminance values on a display also varies considerably for different sensors.

To these variations can be added characteristic differences in dynamic range, resolution, and distortion inherent in a given sensor. The display properties that can influence the observer's interpretation of the information presented by each of three types of sensors to be displayed will be briefly considered: IR mapping, ELINT, and high-resolution side-looking radar (HRSLR).

SPECIAL HANDLING

4.4.1 Infrared Mapping

This sensor is optimum at large depression angles below the horizontal with the aircraft directly over the target area. At long range, the image suffers from perspective distortion and loss of resolution. The pictorial image presented by an infrared sensor can differ in form and outline when compared with optical sensors, but it heightens the detectability of certain targets that possess distinctive temperature gradients. Infrared is better able to penetrate haze than optical sensors, and functions well in total darkness. Also, local "hot spots" such as vehicle engines, warm building, etc., can be seen through conventional camouflage. However, infrared is severely hampered by heavy cloud cover.

Infrared mapping obtained by a line-scan transverse to the vehicle track, combined with scaled motion of the integrating medium (tape) along the vehicle ground track offers high sensitivity and resolution. However, the integrated map, thus generated, suffers from both overlapped data and degraded resolution in parts of the display during yaw turn maneuvers.

In the optimized multi-sensor system, keying signals which exceed the amplitude of preestablished amplitude "thresholds" will be generated from exceptionally hot targets and presented to the real-time display, in addition to the map image. At the time the "hot spots" are separated from the threshold, a time signal and cross-range location code will be added and the entire "key" digitized for use by the display, the keying tape and the data link.

4.4.2 Radar

Since the range capability of radar is greater than optical or infrared, it provides a tactical reconnaissance advantage because it can supply ground target information at distances of 50 to 100 miles. The high

SPECIAL HANDLING

4-119

SPECIAL HANDLING

resolution capabilities of HRSLR anywhere within its range can provide target characteristics close to those of a pictorial display. However, the displayed radar image does vary from optical and infrared images in target and background relationships because of differences in distribution of signal strength. Since radar operates best at relatively low grazing angles, shadowing effects will also influence target and background display.

A primary advantage of the radar display in comparison to optical sensors is its capability of providing ground target returns in any weather. A disadvantage is that it is an active system, which is of some concern when entering a hostile environment.

In addition to the capability of the HRSLR to generate a map-type image, it also has the unique capability of providing indication of moving targets. The spot images produced by the moving target indicator (MTI) result from the component of target motion normal to the broadside direction of the radar antenna in the reconnaissance aircraft, and can be compared to a threshold as in the case of the IR hot-spot signals. The MTI threshold, however, is a velocity threshold, instead of an amplitude threshold, and allows only moving targets above a prescribed velocity (in the vicinity of 5 mph) to be passed. The key to be displayed by this sensor consists of the target velocity and heading as well as its time of arrival and cross-range location. Because of the large amount of airborne equipment required to derive the high resolution radar map in the reconnaissance aircraft, and the doubtful value of the map display to the reconnaissance observer, only the radar MTI keys will be displayed.

4.4.3 ELINT

ELINT sensor information has traditionally been confined to operator analysis displays. The ELINT operator has been the intelligence device for identifying radars. The proposed ELINT output data are the identification

SPECIAL HANDLING

of prescribed emitter functional types and the symbolic display of emitter targets. Thus, prescribed emitter functional types and their location become the keys presented to the situation display.

4.4.4 Display Combinations

Rapid, precise identification and location of significant targets requires that information be presented to the observer using the several sensors cooperatively in a multisensor display. Simultaneous use of several or all of the available sensors suggests: (1) the separate display of each form of information simultaneously, (2) the presentation of one sensor at a time in some desired sequence, or (3) the combination of sensors by controllable display superposition.

The first approach is obviously limited by the number of separate displays to which the observer can attend, the display size and number permissible in a cockpit. It is almost certain that the observer could not correlate data from such an arrangement satisfactorily because of data rate limitations.

The second approach allows flexibility of sensor selection at any phase of the mission. However, it forces the observer to relate the different sources of information to one another over a period of time. Scale factors also have to be kept in mind by the observer from one presentation to another.

The last alternative, with some degree of variation, is recommended as the most attractive approach, since it permits the sensor displays to complement one another. Thus, information from one sensor may be superposed or added to the display of another, at the observer's option, to enhance target recognition or to extend geographical coverage.

SPECIAL HANDLING

4-121

SPECIAL HANDLING

4.4.5 PHOTO/Infrared

Since these sensors provide literal display data of nearly equal resolution, and since optimum pictorial information is achieved when the vehicle is near or directly over an area of interest, one or the other is sufficient for the observer's map display. However, since the IR sensor provides as good a return at night as it does in daylight, it has a slight advantage in this respect. A final advantage of the IR sensor over the PHOTO, for the real-time observer's display, is the fact that the real-time IR display is much simpler to generate and requires less equipment in the aircraft than the photographic display. The conclusion reached is that the use of only the IR map-type display is preferred for the map-like image on the observer's display.

4.4.6 Radar/ELINT

These sensors should provide a highly compatible combination, since both can be used at considerable distances from a hostile area. ELINT target information and MTI information will enhance the identification and location of potential threats or desired targets.

4.4.7 ELINT/IR

ELINT also would be compatible with the map image or hot-spot coded information of the infrared sensor, since it can continue to provide symbolic indications of the electronic environment and potential threats when close to the target area.

4.4.8 Radar/Infrared

This combination is desirable in that the infrared returns display both map and "hot" objects (unique targets) for superposition with the radar MTI information.

SPECIAL HANDLING

4.4.9 Display Coding

Coding of the display to identify targets can be based on target type, and target priority. The code dimensions may include: numerals, letters and/or symbols for target identification; shape coding (geometric figures) for priority coding with no more than 15 priority levels; and possibly color to augment the basic coding scheme. If compound coding is required, the numerals (or letters) could be surrounded with an appropriately colored geometric figure.

In a dense target environment, the display of many target signatures and threats could tax operator search and decision making. To minimize this the optimum brightness level and contrast ratio are required, with a clear definition of coded symbols.

Numerals or letters should be no smaller than 5 minutes of visual angle, with the maximum dimension of any geometric code symbol subtending no less than 10 minutes of visual angle. Symbol density should be kept to a minimum on the display because the search time required to find a numerical symbol has been shown to increase rapidly as the number of symbols exceeds 25.

4.4.10 Physical Display Characteristics

Assuming optimum display location (about 15 to 30 inches from the observer's eyes), the more critical aspects of combining display information will be concerned with the following:

Display Size and Scale Factor

The larger the display, the greater the increase in observer search time. However, the optimum display sizes and scale factors may vary depending on the technique used. For example, radar recognition has been found to be best for a 12-inch display, and decreases rapidly as the 5-inch display size is approached.

SPECIAL HANDLING

SPECIAL HANDLING

and by any control actions he may be capable of performing. An adjunct to the real-time display must be provided, therefore, to enable his tactical "keys" to be inserted into the data chain with the other sensors, and to provide him with the sensor controls required. A "push-button" type of keyboard is recommended for his communication outlet. By proper attention to the human-factors engineering involved in the design of the keyboard, it could be made to handle the observer's comments and observation, (keys) plus the control of sensor data transmission to the carrier over the data link and HF channels. The keyboard lends itself readily to the instrumentation of the digitally-coded communications link. By formatting the output of the keyboard in the same digital language being placed on the keying tape, the observer's contributions on the tape will function in identically the same manner as the other sensor keys, to expedite and control the ultimate separation of the highly significant data from the total take.

4.4.14 Typical ELINT Display

This section describes an ELINT display concept which facilitates the correlation of ELINT with MTI keys and with IR mapping. The guidelines established in the previous discussion were used in the derivation of the display concept.

The conceptual ELINT display is shown in Fig. 4-42. The display is stabilized about the aircraft position with the projected ground track vertical. The range scales are a function of altitude, with the appropriate display circuit parameters and scale numerals selected by the ELINT computer.

Each emitter is identified by a single letter descriptive of its function, i.e., "M" for missile control, "S" for surveillance, and so forth, and is displayed at its computed position relative to aircraft. The emitter location is updated several times as the aircraft approaches it, the fresh location printouts being bright, gradually fading away as they are superseded by new printouts. The most accurate location data is printed as the aircraft passes the emitter, because of the favorable relative bearing and the large number of previous bearing fixes obtained.

MTI and IR hot-spot keys are also printed on the display, with special symbols used for each (circles for all moving targets and squares for all hot-spots, for example). The map image from the IR sensor appears in the background

SPECIAL HANDLING

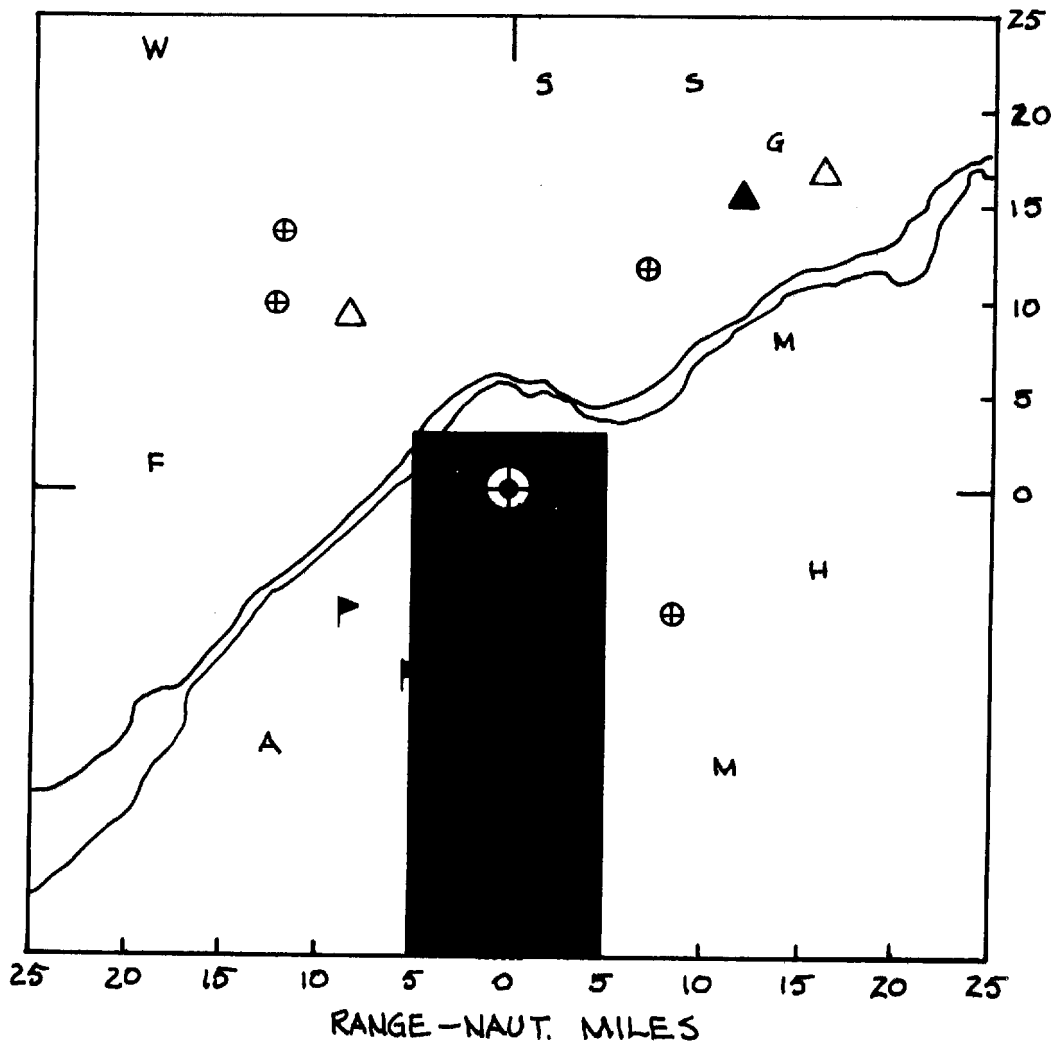

Fig. 4-42 — ELINT situation display.

SPECIAL HANDLING

SPECIAL HANDLING

4.4.11 Luminance and Contrast

Minimum resolvable visual angles depend upon brightness level and contrast ratio. Summations of brightness may prove beneficial to detection, using display combination or superposition, but contrast changes are likely to affect symbol detection adversely if not properly adjusted.

4.4.12 Orientation and Navigation Display

If the multisensor activity information is displayed over a map pattern analogous to the terrain below, there is an advantage in showing target signatures or threat indications in geographic relation to the aircraft and to one another. This makes possible more immediate and accurate responses to threats and targets. The map-type display is most effective when only the significant data from each sensor (heavily filtered and coded) are superimposed on the map background.

It is likely that much of the observer's interest will be ahead and to the side of the reconnaissance vehicle. But enough interest should remain for threats and overlooked areas to warrant the use of almost a full 360-degree map display. If the aircraft symbol is positioned somewhat near the center, with the moving terrain and target symbols changing beneath it (that is, a plan view), a realistic "situation" display will result.

4.4.13 Observer Keying

The primary reason for the observer's display is to assess him of the tactical situation at hand. Through the instantaneous display of the high-priority data being collected, he can contribute to the intelligence being gathered by the addition of his own observations and evaluations,

SPECIAL HANDLING

of the display plus a synthetic map of the battlefield area to be covered by the flight. The synthetic map would be moved in synchronism with the aircraft flight path by signals from the aircraft navigational equipment. Each map image can be independently faded into the background at the convenience of the observer.

The most difficult problems associated with the presentation of the superimposed sensor displays occurs at low flight altitudes because of the disparity in the coverage areas of the three sensors and the speed at which the area is overflown. The problem in coverage area is illustrated in Fig. 4-43 for a flight altitude of 500 feet. At this altitude the ELINT system can "see" to the radio horizon, which is approximately 30 miles. The IR sensor, however, can only discern its map image and hot-spot keys, with any degree of reliability, to a range of 0.5 nautical miles while the high-resolution side-looking radar can see with good fidelity to 1.5 nautical miles.

These ranges for the IR and radar sensors are based on usable angles of 80 degrees and 87 degrees, as shown in Fig. 4-43. A value of 60 degrees is customarily used as the outer limit for recognizable imagery for the IR, but for hot-spot keying, angles as large as 80 degrees may be usable. The radar can see further, and will display approximately an 8 nautical mile strip of range. Therefore, its minimum range scale is shown as 4 nautical miles on Fig. 4-43. Values of R versus α for other flight altitudes are also tabulated for each sensor on Fig. 4-43.

The difficulty in display at the low altitudes is thus apparent. If very short range scales are employed to favor the IR, full advantage will not be taken of the forward looking keys from the radar and ELINT sensors. If larger range scales are employed to favor the radar and ELINT, the IR hot-spot keys will be crowded in the center of the display. At high altitudes, all sensors will cover a large view, as may be seen from the values of R versus altitude tabulated for each sensor on Fig. 4-43, and the correlation of keying will be excellent.

A number of solutions are practical to solve this scaling problem at the low altitudes, and the following will be discussed here:

1. Multiple scales
2. Off-scale annotation
3. Logarithmic scales
4. Dual plots

SPECIAL HANDLING

4-127

SPECIAL HANDLING

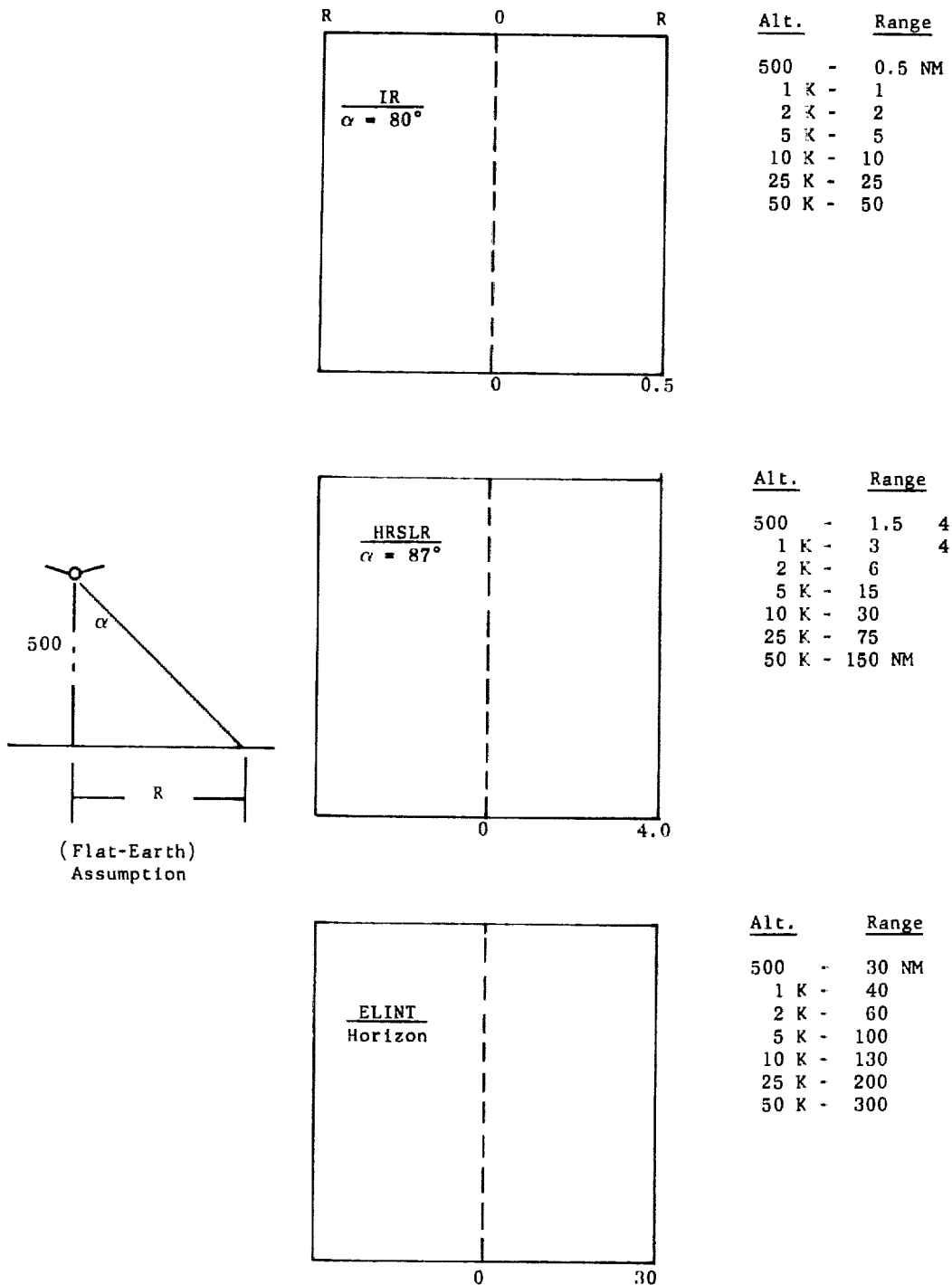

Fig. 4-43 — Sensor coverage areas (500 feet altitude).

SPECIAL HANDLING

In the multiple-scale display, the observer will have three range scales labeled IR, Radar, and ELINT respectively. When set to one of these positions the range scale will be automatically adjusted as a function of altitude (by the airborne computer) but will follow the program for the sensor selected, as shown in the small tables of Fig. 4-43. All sensor keys will be displayed at their correct location, regardless of which scale function is being used, but will be favored according to the observer's selection. If the ELINT scaling should be selected, for example, a thirty mile full scale will be displayed at 500 feet altitude and the display will look like Fig. 4-42. In this display IR hot-spot keys will be crowded in the center 1-mile rectangle as shown, while the radar moving target keys will be contained within the large 10 mile rectangle, looking forward. Conversely, if the IR display scaling were selected, the full scale range at 500 feet altitude would be only 1 nautical mile (± 0.5), automatically varying with altitude as shown in the IR table of Fig. 4-43. Some of the radar, and most ELINT keys would fall outside the displayed view (perhaps in the margin so that they will not be lost to the observer) and the display will favor the IR sensor.

Although the multiple-scale system will not completely correlate the observer's display for low altitude multisensor viewing, the keying signals will not be lost or distorted on the keying tape and full correlation can be done on board ship. The aim is to provide the observer with a simplified display useful for overall evaluation of the situation.

In the off-scale annotation type of display the range is automatically programmed with a short range scale at the low altitudes, and off-scale keys are displayed in the margin. The same function can be achieved by one of the switch positions in the multiple-scale technique.

Logarithmic scales appear to be a useful solution for this application, since they expand the inner and compress the outer portions of the scale in exactly the manner desired. However, polar plots must be used to maintain the true angular bearing relationship of targets to the aircraft with the log coordinate, and severe X-Y distortions exist with this type of display.

SPECIAL HANDLING

4-129

SPECIAL HANDLING

In a dual-plot arrangement of displays, a small display would be supplied just for long-range ELINT targets, and the proportionally-scaled displays reserved for the IR and radar. Short-range ELINT keys would still be present on the IR radar display.

To make the low-altitude IR map image useful to the operator, it must be stopped for examination. This can be done by depressing a stop button at the correct moment. However, the image moves so fast at low altitudes that the normal reaction time makes timely action difficult. One solution available to aid the operator in this respect is to automatically "freeze" the display whenever specific keys from any emitter appear on the display. Target keys produced ahead of the aircraft by the radar and ELINT would be used for control of the display. However, the keying tape (in conjunction with the airborne computer) could be employed in a number of ways to control the observer's display. Since automatic freezing of the display is not necessary at altitudes above 3000 feet or so, because of the greater amount of time available to the observer, a manual freeze can also be used.

Note the freezing of the IR map data will result in missing data frames. Keying data continue to be supplied to the keying tape and to the data links. Since forward looking keys are used to control data framing, the operator, (in conjunction with visual reconnaissance), is better able to assess the mission situation. Thus, improved operator keying plus better data priority ordering and data linking to the carrier will result.

It should be emphasized at this point that when the keying tape data is being transmitted to the carrier by either the wideband and/or narrow-band data link, a real time display, identical to the observer's display in the air will also be functioning on the ship. Thus, identical "freeze" functions are also available to the reconnaissance analyst.

A valuable reconnaissance contribution can be provided by applying the analytical judgment available in the observer. In applying this capability in the context of high performance aircraft, one must consider the problems as well as the advantages of direct visual observation.

SPECIAL HANDLING

In a dual-plot arrangement of displays, a small display would be supplied just for long-range ELINT targets, and the proportionally-scaled displays reserved for the IR and radar. Short-range ELINT keys would still be present on the IR radar display.

To make the low-altitude IR map image useful to the operator, it must be stopped for examination. This can be done by depressing a stop button at the correct moment. However, the image moves so fast at low altitudes that the normal reaction time makes timely action difficult. One solution available to aid the operator in this respect is to automatically "freeze" the display whenever specific keys from any emitter appear on the display. Target keys produced ahead of the aircraft by the radar and ELINT would be used for control of the display. However, the keying tape (in conjunction with the airborne computer) could be employed in a number of ways to control the observer's display. Since automatic freezing of the display is not necessary at altitudes above 3000 feet or so, because of the greater amount of time available to the observer, a manual freeze can also be used.

Note the freezing of the IR map data will result in missing data frames. Keying data continue to be supplied to the keying tape and to the data links. Since forward looking keys are used to control data framing, the operator, (in conjunction with visual reconnaissance), is better able to assess the mission situation. Thus, improved operator keying plus better data priority ordering and data linking to the carrier will result.

It should be emphasized at this point that when the keying tape data is being transmitted to the carrier by either the wide band and/or narrow-band data link, a real-time display, identical to the observer's display in the air will also be functioning on the ship. Thus, identical "freeze" functions are also available to the reconnaissance analyst.

A valuable reconnaissance contribution can be provided by applying the analytical judgment available in the observer. In applying this capability in the context of high performance aircraft, one must consider the problems as well as the advantages of direct visual observation.

SPECIAL HANDLING

4-131

SPECIAL HANDLING

The observer's keying display will be in constant operation from the GCI line until departure from hostile territory. The observer will constantly monitor this display to ascertain combinations of superimposed keying data indicative of critical fleeting target activity. Activation of those sensors limited to intermittent operation will, in large measure be initiated by the observers analytical judgment of the meaning of data on the keying display. Diversion of the observers attention from this display could disrupt his concentration and increase the probability of missing important data for sensor activation.

In the context of high performance aircraft, direct visual target observation in both the high and low operating envelopes cause severe problems. In the low mode at a velocity approaching Mach 1, the period a point target remains under observation even if the observer has been alerted to its presence and picks it up immediately, is too short to perform reliable identification much less activity analysis. Without some external cueing assistance, there is a high probability that a point target will pass totally unobserved. Operating at Mach 2 or more in the high envelop, the observer can only perform a gross target analysis with the unaided eye. A more detailed target evaluation will require considerable magnification using optical or electro-optical devices. A number of possibilities have been considered to aid the observer in direct visual observation as follows:

1. An optical or electro-optical viewer with automatic pointing controlled by the keying data vector information generated for the display and activated at specific thresholds of key data activity.

2. An optical or electro-optical viewer automatically pointed by the keying data vector information activated at the observers option to points selected from the keying display.

3. An instantaneous video recording of a target selected by techniques described in 1 and 2 above, to be:

- a. viewed by the observer
- b. transmitted to the carrier for analysis
- c. both the above options

SPECIAL HANDLING

Considering human limitations as well as operational problems options 1, 2 and 3(a) would divert the observers attention from the keying display. In addition at low and high altitude option 1 in an active hostile environment the system would tend to change from target to target at a very high rate, totally confusing the observer. Option 2 has limited merit for high altitude operation provided the input optical system could be made to track a point for a sufficient time to permit analytical judgment. At low altitude option 2 becomes ineffective because of the extremely short time the target remains in line of sight. Option 3(a) under observer control would provide the necessary target image persistence, but while the observers attention was diverted to permit image analysis, the acquisition of additional images based on the keying display would cease option 3(a) under automatic control could produce a volume of imagery which would exceed the observers capability to keep abreast of the current environment. Option 3(b) under observer control is the only combination of techniques and equipment permitting selective acquisition of meaningful imagery and providing these data to an environment where proper analysis and correlation can be applied and where the analysis can result in appropriate command action.

SPECIAL HANDLING

4-133

SPECIAL HANDLING

4.5 AIRBORNE DATA PROCESSING

The general conclusion regarding timeliness as derived from the operational analysis clearly emphasizes the requirement for shortening the time required for providing viewable material to the analyst. In this area then, the case becomes clear for airborne processing of all records to the point of viewability. With the IR, SLR and photographic material, onboard, in mind that the number of records were reduced to a minimum. An additional problem is present if the coherent radar system is used. The radar system requires an optical correlation step between the first film record and a viewable image. The weight/volume requirements of such equipment suggest that it be ground based, thus the SLR processed film should read out over the wide band data link if possible, to shorten the availability time of the imagery so that it is ready when the aircraft returns.

The ELINT information will be processed in flight so the data will be available on tape when the aircraft returns from the mission.

Because the need for IR detail arise only during intensive analysis of a small area, a redundant record will be made from the primary IR magnetic tape. The imagery film record will be produced from the tape on the aircraft, and inflight processed to produce a readable film upon recovery of the aircraft. This image will be the prime IR record for analysis, with the tape containing the fine temperature information available for detail work as required.

There is electronic format imagery available from the IR and the SLR system; however, the photographic imagery would not add significantly to the available records for real time use. Because of the degradation from the real data content required for transmission in near real time, and the complexity of the equipment required to produce this degraded transmission, there is no suggestion for photographic imagery transmission in the system concept.

4.5.1 Airborne Photographic Processing

The case for airborne processing has been discussed and it was determined that the processing scheme of such a system would produce 1) a positive image and a negative, 2) maximum film resolution and 3) minimum system complexity.

SPECIAL HANDLING

The purpose of airborne processing is to save time, and while producing a negative is such a saving, the final desired product is a positive transparency. Under this requirement, the processing system utilizing a saturated film material which forms a positive by diffusion has been selected as meeting the requirements. This system is typified by the Eastman Kodak Bimat process, although other similar materials are available.

Each of the photographic sensors then will incorporate a processing magazine so that the positive imagery is available on return of the aircraft. There is no significant degradation in resolution on the films in probable use with the system.

4.5.2 Airborne Infrared Processing

The electronic signals from the infrared scanner are processed to obtain keying data and to provide high resolution imagery. The high resolution information is recorded for interpretation in the intelligence data processing center. This data is also transmitted in essentially real time by a wide band data link. Low resolution imagery is displayed upon request by the observer. The keying information is displayed to the observer and also recorded on a separate keying tape which is transmitted in real time on a separate data link.

The data processing includes combining the detector channels to obtain required resolution element size, amplitude threshold, and formatting for transmission or display.

Prior to thresholding or decision making, the data remains in analog form. Signals exceeding threshold are converted to digital format which includes position, amplitude, and time information. The infrared imagery remains in analog format, and the keying information is presented in the digital format.

The IR signal may be recorded directly on magnetic tape for delayed transmission and/or permanent storage. If it appears desirable from the standpoint of correlation with the photographic sensor, the IR data may, alternatively, be recorded on film and processed in a similar fashion to the photographic record. The disadvantage of employing film is that the quantitative nature of the IR

SPECIAL HANDLING

4-135

SPECIAL HANDLING

data is impaired. The advantages of high storage density and comparable record handling and data transmission equipment may outweigh the quantitative considerations, particularly if the primary use of the IR imagery is for visual interpretation and the only automatic processing is that performed in near real time under control with the operator.

The bandwidth of the IR video data is sufficiently narrow (5 megacycles) so that it can be handled on a real time microwave transmission link. Alternatively transmission may be delayed and altered in time scale by including a storage medium such as magnetic tape or photographic film.

4.5.3 Airborne SLR Processing

Electronic or coherent optical signal processing techniques may be employed to process the synthetic array radar raw data to obtain imagery maps or to process the data for moving target indication. With the present state-of-the-art, electronic processing has proved less efficient than coherent optical processing, in terms of the weight and power required for processing at a specified data rate (in resolution elements per second). Further developments in storage media and electron beam technology may make electronic processing attractive in the 1970 era. Even with the present state-of-the-art, electronic processing can be used for moving target indication while in flight, although the number of range resolution elements is restricted.

There appear to be very good reasons to perform inflight signal processing to obtain moving target indications, since this indicator can be used as an alerting and keying device for the radar imagery and other sensors. However, there appears to be little reason for doing in-flight image processing just for the purpose of presenting the output to the aircraft observer, since the observer does not have sufficient time to absorb the information at the sensor output data rates from even one of the imagery sensors. Therefore, the principal reason for doing in-flight processing of imagery is to shorten the time involved in transferring the imagery from the aircraft to the carrier, and then to the reconnaissance analyst. It is not clear whether this time saving is commensurate with the additional amount of airborne equipment required, with the resulting problems in weight, power, complexity, reliability, and cost.

SPECIAL HANDLING

4.5.4 ELINT Airborne Data Processing

The airborne data-processing elements are depicted in three blocks at the bottom left-hand side of the Optimized Multisensor System Diagram, Figure 4-44. These blocks are labeled Signal Process, Recorder and Storage.

The signal process block consists of several units depending on the exact configuration of the system. Typically the units are: (1) the logic and control system (computer), and (2) an auxiliary data converter with a digital clock.

The logic and control function is applied by a high speed, microminiaturized, general-purpose digital computer. Typical characteristics for such a computer are a 1-mc clock rate, a word size of 30 bits with a memory expandable to 32,000 bits in 8K modules, and an access time for conventional (core) memory of 2 usec with a cycle time of 6 microseconds. The normal add time is 6 microseconds. There is also a 256-word thin-film memory having a 1 microsecond cycle time. The computer has 7 index registers. It provides no indirect addressing and no wired-in, floating-point arithmetic. The 89 instruction complement includes block transfer and block mask-and-compare instructions, and cumulative summation. Asynchronous, simultaneously-buffered I/O channels can be provided with a total maximum transfer rate of 160-thousand 30-bit words per second. The machines are fully ruggedized.

The auxiliary data converter is required to change the format of the data obtained from the auxiliary data-handling system within the aircraft. The signals are usually supplied from the data-handling system in excess-3 binary-coded decimal. The computer uses a straight binary code. The converter will change the code of the signals supplied, and assemble 30-bit computer words for quick and efficient transfer into the machines. In the same unit with the auxiliary data converter is the digital clock. It consists typically of a 1-Mc crystal-oscillator counter and other required logic to produce a 17-bit binary time code. This will be read in with the parameter data from the receiver as time-of-arrival (TOA).

The recording and storage function is performed by a magnetic-tape digital data recorder. A typical recorder has a 16-track tape deck designed specifically for severe environments. It uses a 1-inch tape and has a capacity of up to

SPECIAL HANDLING

4-137

SPECIAL HANDLING

2400 feet. The recording is on 16 tracks, and the density can be made as high as 1000 frames per inch, though only 500 per inch is typically used.

Figure 4-45 is a diagram illustrating data flow in the signal processing equipment. Pulse words from the receiver enter the auxiliary data converter where time-of-arrival information is affixed. Navigation data is also transmitted to this unit where it is formatted for recording. The output of the converter unit is transmitted to a buffer store, and then to the recorder.

The buffer output is also sent to an Ax-E1 filter that selects all pulse words that are received in the forward sectors. These selected pulse words then undergo correlation, which converts the series of pulses received from an emitter on each receiver scan into a single word representing the complete pulse train. Deinterleaving is also formed at this point.

In deinterleaving, an attempt is first made at separation of the pertinent sorting parameters such as frequency, direction, pulse width, and pulse amplitude. The test for a successful data reduction is pulse-repetition-interval coherence in a sorted pulse train. The deinterleaving technique recommended is one that Airborne Instruments Laboratory has used in other data processing systems. It depends on a hypothesis-testing procedure in which test pulse-repetition-intervals are formed by computing time-of-arrival differences between neighboring pulses; these time intervals are tested to see whether they will correlate with any pulses in the train. The test interval is stepped through the pulse train to determine the correlation. If correlation is achieved, the correlated train is extracted from the signal sample, and the remainder has the same procedure applied to it repetitively, until no further reduction can be achieved.

Correlated pulse trains are then checked with the key-threat parameters, which have been loaded in the computer before the mission. If a match is found, a signal is sent to the mode-control logic section which initiates the high-scan-rate mode of operation required for real-time emitter location. Intercepts from key emitters are also stored to provide a history from which the location is computed by observing bearing rate. Located emitters are stored in an output buffer, which sends information on the key emitters to other components of the multisensor system.

4-138

SPECIAL HANDLING

SPECIAL HANDLING

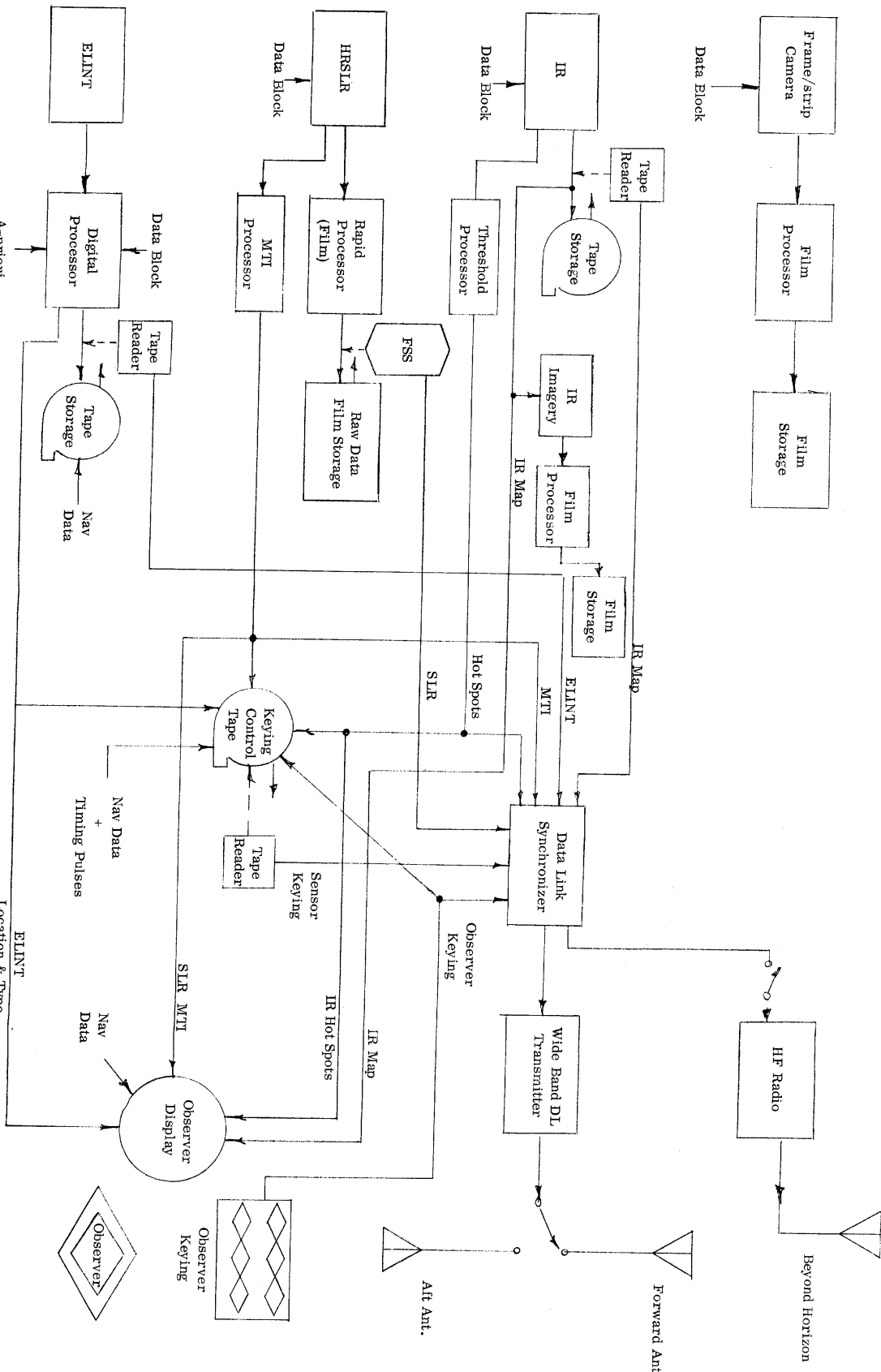
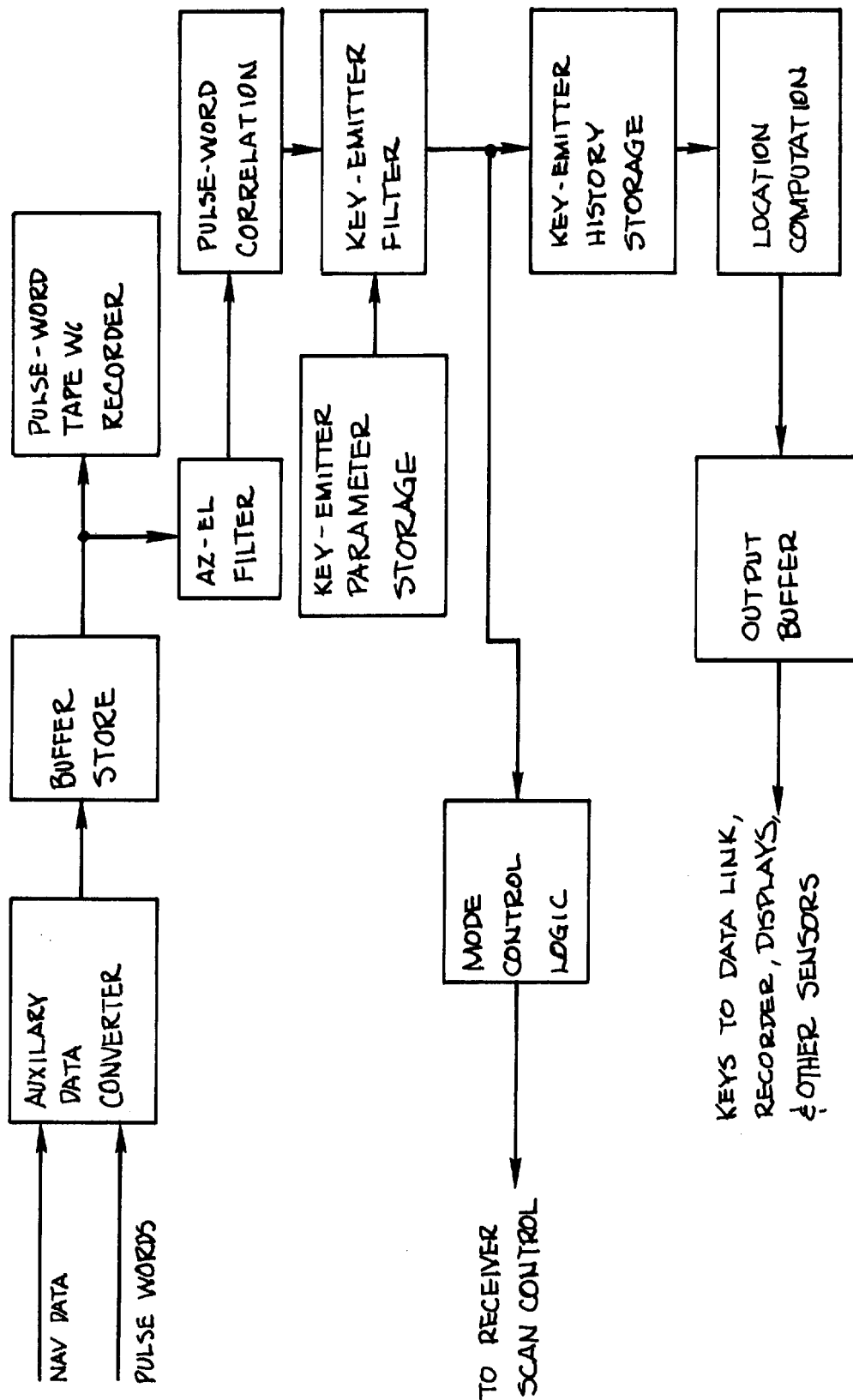

Fig. 2-6 - Airborne system concept.

SPECIAL HANDLING

SPECIAL HANDLING



SPECIAL HANDLING

Fig. 4-45 -- Data processing flow diagram

SPECIAL HANDLING

4.6 DATA LINKS

In the optimized multisensor system concepts, there exists a need for a very rapid system response time for some types of data. This can be accomplished by the addition of a real-time data transmission capability. Such a transmission link is not only important for the instantaneous reporting of "activity" information, observer's comments and data on fleeting targets (such as sensor "keying" signals), but it also can serve to reduce the overall intelligence processing cycle, under some circumstances, by getting sensor imagery back to the carrier before the reconnaissance aircraft itself returns. For signals and data of the very highest priority, it would be desirable to have such a link, even when the reconnaissance aircraft is beyond the line-of-sight to the carrier.

To fulfill this task, such a data link must transmit data of sufficient quality and quantity to reliably support tactical decisions at the intelligence center on the carrier. Since the reconnaissance aircraft, under most circumstances, will return to the carrier in 1 to 2 hours with the original high-resolution data collected by the sensors, the output resolution quality of the link can be sacrificed, to some degree, for a more reliable, longer range, real-time link. The acute need for the real-time imagery at the carrier is not for the high-resolution content of the imagery, but for the timeliness of critical data. In fact, all available information indicates that an output resolution of approximately 20 line-pairs per millimeter at the real-time display equipment on the carrier is adequate for the purpose. Consequently, the design of the wideband data link is based on that level of performance at the output displays.

To extend the range capability of a wideband data link to over-the-horizon transmission, as is necessary when the reconnaissance aircraft is beyond the line-of-sight path to the carrier, a relay repeater must be used. However, the problems involved in providing such a relay, even when the relay platform is only a conventional high-flying aircraft, are so severe that no operational multisensor data links are available today. These problems are concerned primarily with the pointing of the antennas between the reconnaissance aircraft and the relay aircraft (or platform) as they maneuver, but propagation multipath,

SPECIAL HANDLING

and many other factors, also contribute to the difficulties involved. Therefore, for purposes of this study the relay vehicle or equipment will not be considered; however, the system should be configured so that its operation with a relay in the future would be possible without changes being made.

Since the high priority, activity-type data is of a low data rate, an investigation was made to determine whether these data could be sent over a standard aircraft communication link. The supporting analysis, which is contained in this section, demonstrates that these data, including the keying signals, can be accommodated as digital data within the voice channel of a single sideband transmitter. If a high-frequency transmitter can be made available on the aircraft, a beyond-the-horizon capability will be provided for these important data.

The presence of the data link equipment on the reconnaissance aircraft should in no way constrain the maneuverability of the aircraft, or significantly degrade its performance. These, and the previous considerations, have delineated the guidelines to be used in the design of the airborne data link equipment.

4.6.1 Data Link Concept

A conceptual presentation of the data link's role in the overall multisensor system is given in Fig. 4-45a. This concept includes optional features which can be traded-off against such system characteristics as communications reliability, operational versatility and technological realizability. The reconnaissance aircraft carries the data collection subsystems, data processors, data storage units, a narrowband data transmitter and a wideband data transmitter. The system handles two categories of data:

1. Keying Data which are generated by the onboard sensors and observer, and which is considered of prime interest and of high priority.

2. Bulk Data which comprise the main body of the sensor data to which keying data have been added.

The narrowband data link provides a real-time capability beyond the line of sight for the keying data. The other link provides wideband transmission of the bulk data to receivers within line of sight (or beyond, if a suitable repeater relay is employed).

SPECIAL HANDLING

4-143

SPECIAL HANDLING

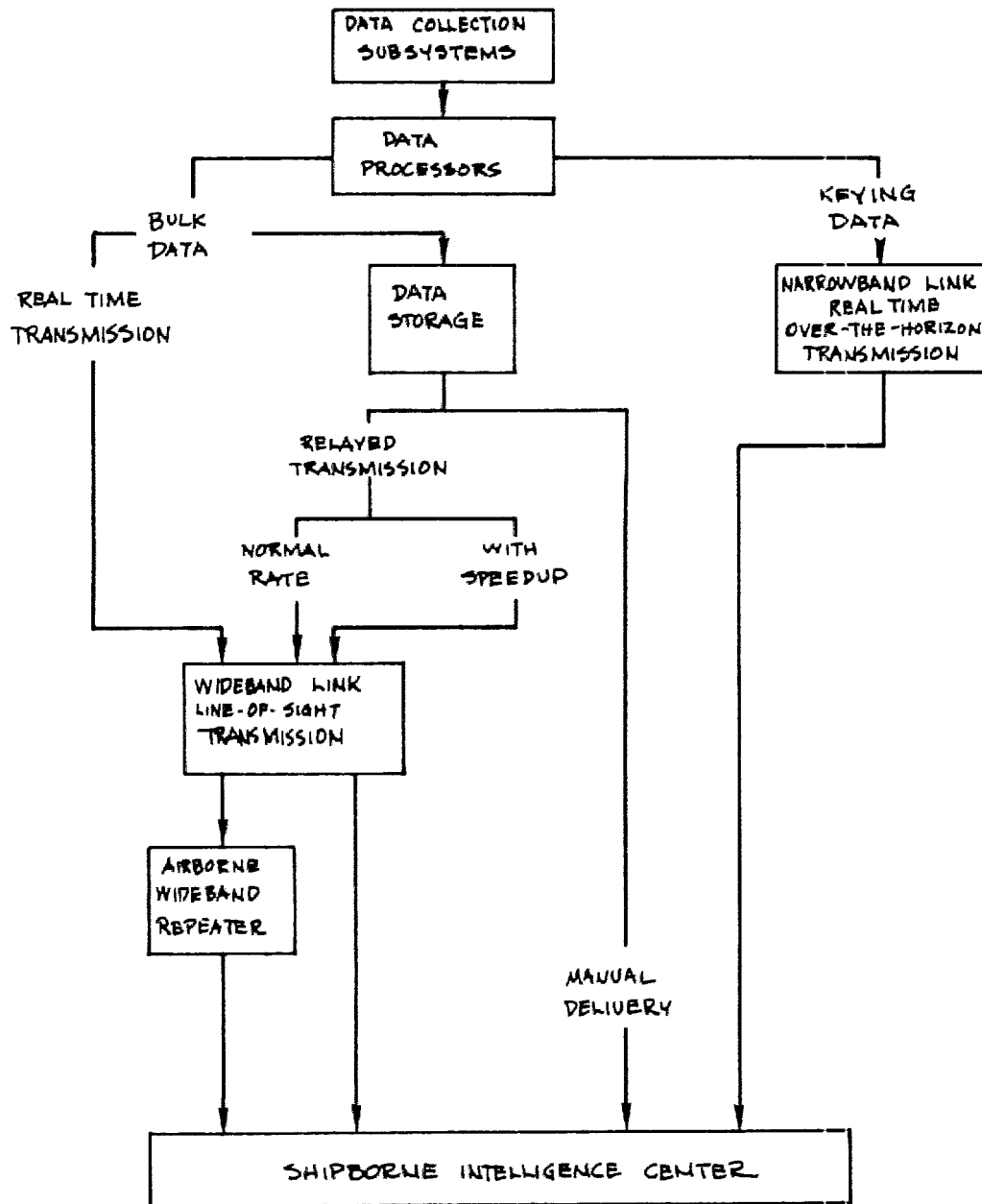

Fig. 4-45(a) — Conceptual data link.

SPECIAL HANDLING

SPECIAL HANDLING

For the bulk data, two cases are of interest.

Case 1 — Delayed transmission in which the reconnaissance aircraft stores the wideband data until it is within a favorable line-of-sight condition with respect to the receiver, and then transmits it.

Case 2 — Real-time transmission in which the data are transmitted as soon as collected, with the reconnaissance aircraft within line-of-sight of the receiver. This case includes operation in which the line-of-sight is extended by means of a repeater relay on a high-flying aircraft or other airborne platform.

Case 1 requires onboard data storage, and does not achieve minimum system-response time of Case 2. Nevertheless, Case 1 has several important advantages over Case 2.

1. Transmission is delayed until the aircraft is a few degrees above the radio horizon, thereby avoiding the higher level of system complexity and transmitter power required to combat multipath, selective fading and inband frequency perturbations.

2. A deeper penetration into enemy territory can be achieved without using an airborne repeater.

3. The active portion of the mission can be flown independently of transmission requirements.

4. The aircraft on its return flight can virtually aim itself at the receiver (presumed to be at the carrier), and effect a fair and highly useful antenna gain. In addition, with a nose-mounted antenna, there is no shadowing or reflections from the aircraft itself, and undesirable pattern lobing is minimized.

Concerning delayed transmission, consideration has been given to speeding up the playback of the stored data to permit trading reduced readout time for increased transmission bandwidth. The feasibility of this technique depends on the system bandwidth required at the normal playback rate. Both the data storage and the data link itself impose constraints on the maximum bandwidth which can be accommodated by the system.

SPECIAL HANDLING

4-145

SPECIAL HANDLING

About a three-to-one speedup (with the subsequent transmission time reduction to one-third its normal value) would have to be used for the speedup technique to be significant. When video and rf bandwidth figures are compared to airborne recorder and wideband transmitter capabilities, even a two-to-one speedup appears difficult to achieve. Therefore, for the time being, the speed-up technique will not be considered further.

Based on the foregoing discussion, a preliminary data link concept has been formulated to provide a logical structure for more detailed considerations. The basic system aboard the reconnaissance aircraft includes the following equipments:

1. Means for storing and reproducing the bulk data at its normal rate.
2. Narrowband transmitter for the real-time transmission of keying data within line-of-sight and beyond the horizon.
3. Wideband transmitter for transmitting bulk data at its normal rate. The input to this transmitter can be either the sensor data being generated for real-time transmission, or the sensor data already stored for delayed transmission. This equipment is to be compatible with both direct path and airborne repeater operations.

4.6.2 System Engineering Aspects

Data Characteristics — The data link may handle data from six sources, three of them scanned imagery signals and the other three digitized outputs from the onboard data processors. Although the photographic sensor data are not presently assigned to the data link, they are included in the system engineering considerations for the sake of completeness. All references cited in text are given at the end of this section.

Analog Data — The three analog signals are the outputs of the HRSLR, the IR and the photographic sensors. Although these sensing processes are fundamentally different, the electrical signals which are supplied to the data link are each generated by a line-scanning process applied to a two-dimensional scene, which permits discussing them together.

SPECIAL HANDLING

Since the data link is a series element between the analog outputs of the imaging sensors and the recorder-processor-viewing equipment on the aircraft carrier, it is necessary to consider the inherent resolution capabilities of the sensors and the viewer when determining the amount of data link bandwidth required for satisfactory image reproduction. The data link should have only enough bandwidth to provide the output resolution required as limited by the sensors or viewer, since data link implementation is easier, and the resulting system reliability higher, when the video bandwidth requirements are kept to a minimum.

The ground resolution of the camera and IR sensors is a function of the reconnaissance altitude, as may be seen from Fig. 4-46, which is a plot of ground resolution versus flight altitude. In this figure, the lines labeled IR SENSOR and PHOTO represent the ground resolution available on the airborne records of these sensors, respectively, as a function of the flight altitude. The IR system, with a detector resolution angle of at least 0.5 milliradians, for example, can resolve a 30-foot object at 60,000 feet altitude or a 0.25-foot object at 500 feet altitude, with corresponding values inbetween. A camera suitable for use with the data link has a field of view of 120 degrees and a resolution of 60 line pairs per millimeter on 5-inch wide film. At 60,000 feet altitude, this corresponds to a ground coverage of 208,000 feet and a resolution of 35 feet, as shown on the PHOTO curve in Fig. 4-46. The resolution figure is based on 2000 line pairs for 4 inches of usable film width (which equals 20 line pairs per millimeter). Because of the constant 120-degree camera coverage angle, the ground resolution for a given film resolution is also a function of altitude, being 0.35 feet at 500 feet altitude, as shown.

The ground resolution capability of the HRSLR is not a function of altitude, because a constant range scale is used for all altitudes. The HRSLR curve, shown at 8 feet ground resolution on Fig. 4-46, corresponds to the HRSLR capability when using an 8-mile range scale and 60 line-pairs per millimeter resolution on 5-inch film.

The curve labeled REAL TIME VIEWER on Fig. 4-46 indicates the ground resolution capability of cathode-ray tube type viewers which can be used for real-time displays onboard ship. The resolution of these displays is limited by approximately a 0.001-inch beam spot size to 20 line pairs per millimeter. This

SPECIAL HANDLING

4-147

SPECIAL HANDLING

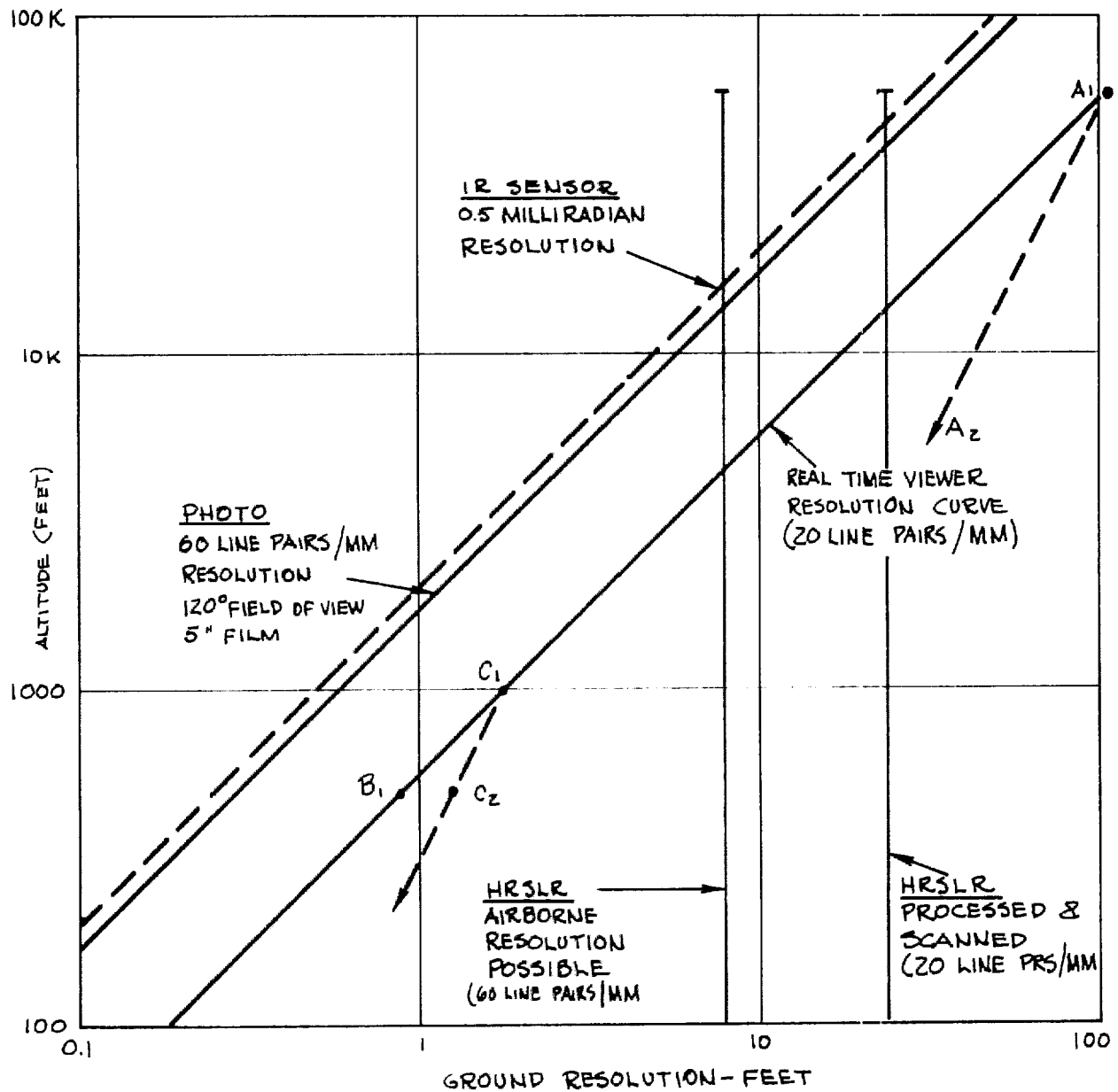

Fig. 4-46 — Imagery sensor resolution.

SPECIAL HANDLING

SPECIAL HANDLING

corresponds to a ground resolution of 104 feet at 60,000 feet altitude, and 0.87 feet at 500 feet altitude, if the ground coverage is equal to the 120-degree field of view provided by the IR and photographic sensors. It is obvious from this curve that if the real-time viewer is used it will limit the resolution of the IR and photographic sensors at all flight altitudes. However, as shown in an early portion of this study, the ground resolution provided by a 20 line pair per millimeter viewer is in close agreement with the ground resolution requirements for tactical intelligence, except at the very high altitudes. Therefore, if the data link bandwidth can be tailored to match the resolution characteristics of the viewer, it will not limit the resolution capabilities of the overall system.

The vertical line labeled HRSLR PROCESSED & SCANNED, at 24 feet ground resolution, represents the resolution available from the HRSLR airborne processor-scanner if real-time transmission of data is required. It indicates the degradation from 60 line pairs per millimeter to 20 line pairs per millimeter resulting from the rapid film processor and cathode-ray tube scanner required in the air to provide a real-time radar map image. Since further processing of this image is required onboard ship before a final image is available, the display of this imagery on a real time viewer will not be accomplished. Therefore, the data link bandwidth required for the HRSLR map image must be based on the 24-foot resolution limitation of the airborne processor-scanner.

The video bandwidths required to be handled by the data link in order not to degrade the resolution of the real-time viewer for photo or IR imagery, or the 24-foot resolution requirement for the HRSLR, are calculated from the number of resolution elements in the ground map image covered per second. For the case of the IR or photographic sensors, where the ground coverage changes with altitude, the bandwidth required is a function of aircraft altitude and speed. In the case of the radar image, where the ground coverage is the same for all altitudes, the bandwidth required is only a function of the aircraft speed. Because of these relationships, the ground resolution versus altitude delineated by the REAL TIME VIEWER line of Fig. 4-46, is not a constant bandwidth relationship, whereas the ground resolution depicted by the 24-foot HRSLR line is. The derivation of the video bandwidth required for the IR or photo map image is, therefore, slightly more complicated than for the radar map image.

SPECIAL HANDLING

4-149

SPECIAL HANDLING

If the video bandwidth required to be handled by the data link for the IR (or photo) real-time viewer were calculated at the high-altitude end of the real-time viewer curve (point A_1), for an aircraft speed of Mach 2 and a ground resolution of 104 feet, it would be found to be 0.55 megacycle. However, if this bandwidth were held constant (as would exist in practice), the resulting ground resolution at lower altitudes would follow the square-law curve $A_1 - A_2$, and the overall system resolution would degrade appreciably below the viewer resolution desired, as shown. Conversely, if the bandwidth were calculated at an altitude of 500 feet and a speed of Mach 1 (point B_1 on the viewer curve) the ground resolution would be 0.85 feet and the bandwidth 7.8 megacycles. A good compromise, and the one finally selected, is a bandwidth corresponding to 1.75 feet resolution at 1000 feet altitude and Mach 1 speed, which is 3.9 megacycles (approximately 4 megacycles). The resolution provided by this bandwidth will deteriorate slightly below the desired viewer curve as shown at $C_1 - C_2$, but the slight loss in resolution at 500 feet altitude (C_2 instead of B_1) is a small penalty to pay for the two times reduction in bandwidth obtained. The final IR (or photo) ground resolution obtainable from the 4-megacycles video bandwidth data link for a speed of Mach 2 at 60,000 feet altitude, and a speed of Mach 1 at 500 feet altitude, is closely approximated by the line $A_1 - C_1 - C_2$.

It should be noted, at this point, that the ground resolution of 1.75 feet indicated at the break-point in the curve at point C_1 will be modified slightly upward because of the series effect of a 20 line pair per millimeter data link and a 20 line pair per millimeter viewer. The effect rounds out the curve at the break-point, and allows the curve to approach the line segments as asymptotes at altitudes removed on either side of the break-point.

The video bandwidth required for the HRSIR radar is obtained from the eight mile total range coverage at a maximum speed of Mach 2. The calculations yield a bandwidth of approximately 1 megacycle required to provide the 24 foot resolution, allowing for the slight degradation caused by using the link in series with the viewer.

SPECIAL HANDLING

We now detail the scanning parameters required to achieve 20 cycles per millimeter resolution for the IR or photographic sensor processes. The conditions assumed for these computations are:

Aircraft altitude	1000 feet
Aircraft speed	1000 feet per second (Mach 1)
IR or photographic cross-track viewing angle	120 degrees

A frame of data is defined as one in which the cross-track coverage is equal to the coverage along the flight path (i.e., a square picture, or unity aspect ratio) for a flat earth. This corresponds to an area of 100 by 100 millimeter (assuming 4 inch usable width) on the real-time viewer. For equal resolution in the horizontal and vertical directions, a resolution requirement of 2000 cycles per frame is imposed on the data link.

One cycle of resolution perpendicular to the scan lines corresponds to 2.8 (= 2/0.715) video scan line or "TV lines". The factor (0.715) is referred to as the Kell factor, and is a measure of the average loss of vertical resolution which occurs because the scan lines are not in perfect registration with the horizontal lines in the scanned scene (see reference 2). Therefore, 5,600 TV lines per frame are required to give an equivalent data link resolution of 20 cycles per millimeter.

The maximum frequency required for these channels (see reference 3) is given by:

$$f_{\max} = \frac{1}{2} K m n^2 f \left(\frac{W}{h} \right) \left(\frac{k_v}{k_h} \right)$$

where:

- K = Kell factor (= 0.715)
- m = horizontal-to-vertical resolution ratio (1)
- n = TV lines per frame (5,600)
- f = frames per second (depends on speed and altitude)

SPECIAL HANDLING

4-151

SPECIAL HANDLING

w/h = aspect ratio (= 1.0)

k_v = fraction of field scanning time which is active (= 1.0)

k_h = fraction of total line which is active (0.83)

The numbers in parenthesis have been adopted for this application; some of them are estimates based on standard practices in commercial TV.

For the IR and photographic sensors, a 120-degree viewing angle at 1000 feet altitude covers 3464 feet. At Mach 1, this distance is covered in 3.46 seconds by the aircraft, thus providing a value of $f = 1/3.46$ frames per second. Using this value of f , the video bandwidth required for the IR or photographic sensors is calculated to be 3.9 megacycles.

For the high resolution side looking radar, the conditions assumed for the bandwidth computations are:

Aircraft altitude	60,000 feet (doesn't enter into computations)
Aircraft speed	2000 feet per second (Mach 2)
Range segment	8 nautical miles

Under these conditions, a frame is covered in the time taken for the aircraft to fly 8 nautical miles (48,000 feet), i.e., 24 seconds at a speed of 2000 feet per second.

Using these assumptions and figures the video bandwidth required is calculated to be 0.56 megacycle for a resolution of 20 line pairs per millimeter in the data link itself. However, as discussed earlier, in order to achieve an overall system resolution close to that imposed by the real-time viewer, the equivalent resolution capability of the data link must be somewhat higher than 20 cycles per millimeter because of the deterioration in resolution from both sources. This is, however, a tradeoff situation because the video bandwidth required for the data increases in proportion to the square of the equivalent resolution of the link and becomes intolerably high if too high a link resolution is used. Using an rms rule for the summation of "irresolutions" (see reference 1 - reciprocal resolution in millimeters per cycle) the system resolutions that

SPECIAL HANDLING

can be achieved are tabulated in Table 4-11. The video bandwidth Expansion Factor in the table is the increase in video bandwidth required as a function of the square of the link resolution, as noted above, with unity as the reference for a 20 cycles per millimeter link.

Table 4-11. System Resolution versus Data Link Resolution

Resolution of RPV - *Cycles Per Millimeter	Resolution of Data Link - Cycles Per Millimeter	Video Bandwidth Expansion Factor	Overall System Resolution Cycles Per Millimeter
20	20	1	14.2
20	28.3	2	16.3
20	40	4	17.8
20	60	9	19.2
20	80	16	19.4
20	∞	∞	20.0

*Cycles per millimeter = line pairs per millimeter.

From Table 4-11 we see that a data link resolution of 60 cycles per millimeter or higher is desirable to meet the 20 cycles per millimeter overall system resolution. However, 60 cycles per millimeter entails a video bandwidth expansion of 9 times the amount required for a 20 cycles per millimeter data link, or 4.95 megacycles. If a bandwidth of 1 megacycle is used the data link equivalent resolution is approximately 27 cycles per millimeter resulting in an overall system resolution of approximately 16 cycles per millimeter, or 29 feet ground resolution. Since it is felt that the airborne processing will produce data slightly better than the 20 cycles per millimeter resolution assumed, the 1 megacycle bandwidth link will provide close to the 24 foot ground resolution. At speeds less than Mach 2, the 1 megacycle bandwidth will be more than adequate.

SPECIAL HANDLING

4-153

SPECIAL HANDLING

Because each of the three video signals is derived by an image line-scan process, the resulting spectral distributions of energy are expected to strongly resemble that of commercial TV. Using a typical TV spectrum (see reference 4) as a basis, (Fig. 4-47), a more conservative estimate of the video spectrum shape has been selected for subsequent computational purposes. For the ratio of $f_m/f_1 = 66.7$, the estimated spectra of the HRSLR sensor is shown in Fig. 4-48. For the IR sensor, the spectrum consists of 25 double-sideband frequency-division multiplexed channels. For computational purposes, this spectrum is assumed to be "white".

For image quality, a signal-to-noise ratio is defined as:

$$20 \log_{10} V_{p-p} - 20 \log_{10} V_{rms}$$

where

V_{p-p} = peak-to-peak video signal voltage

and

V_{rms} = rms noise voltage

On the basis of many subjective tests on commercial TV, a S/N ratio (as defined above) of 46 db is considered to be noiseless (see reference 5). For our purposes, the 46 db figure will be used as the minimum acceptable quality. Where digital modulation approaches are considered, the quantization noise will likewise be set at 46 db. In addition, a maximum binary error rate of 10^{-4} is selected as a design value for these systems.

Table 4-12 is a summary of the pertinent data parameters.

The foregoing analyses present several bandwidths for the various sensor configurations. In the system considerations of subsequent sections, the photographic data is assumed to be excluded from the data link, the IR signal is taken to occupy a video bandwidth of 4 megacycle and the HRSLR bandwidth as 1.0 megacycle.

SPECIAL HANDLING

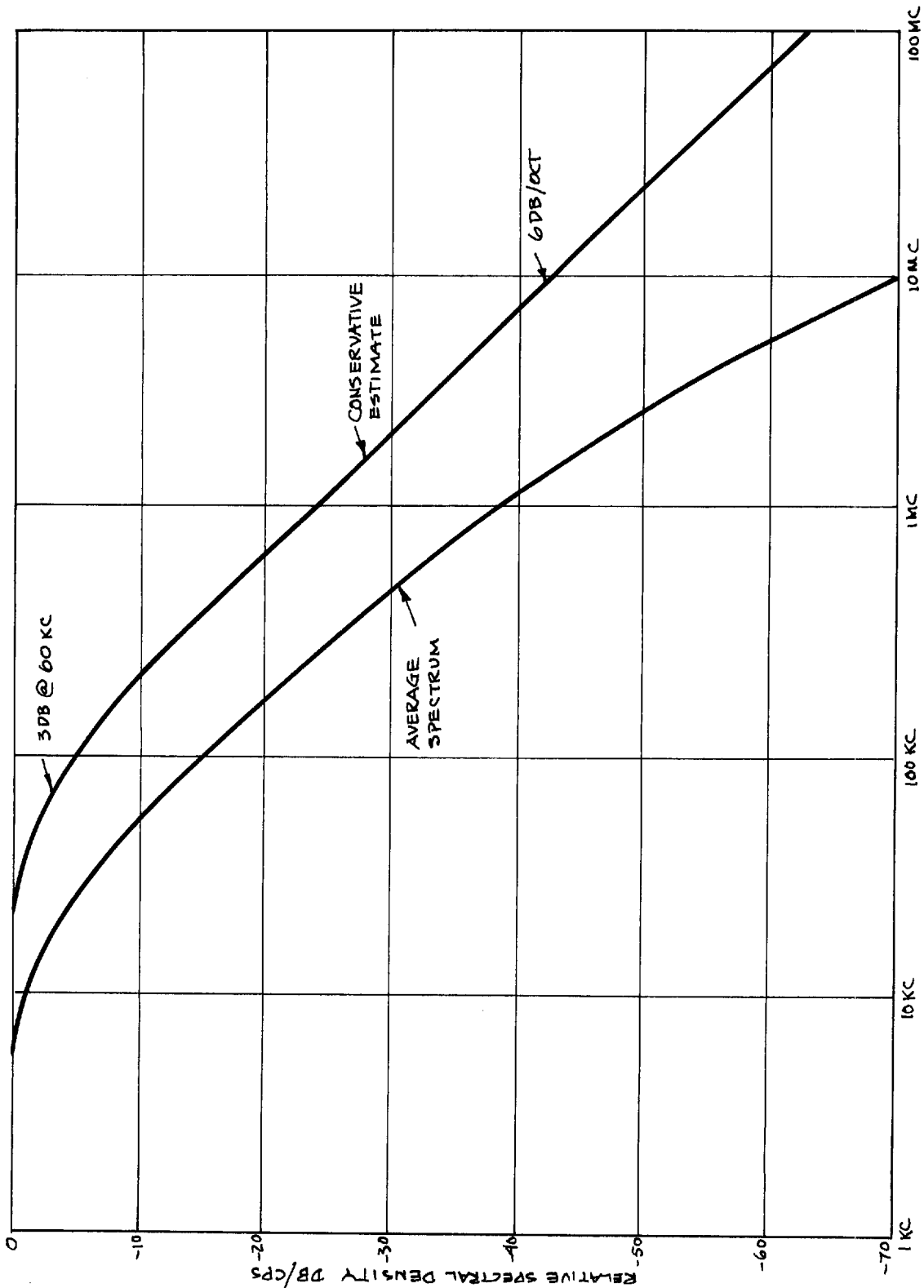

Fig. 4-47 — Commercial TV frequency spectra.

SPECIAL HANDLING

SPECIAL HANDLING

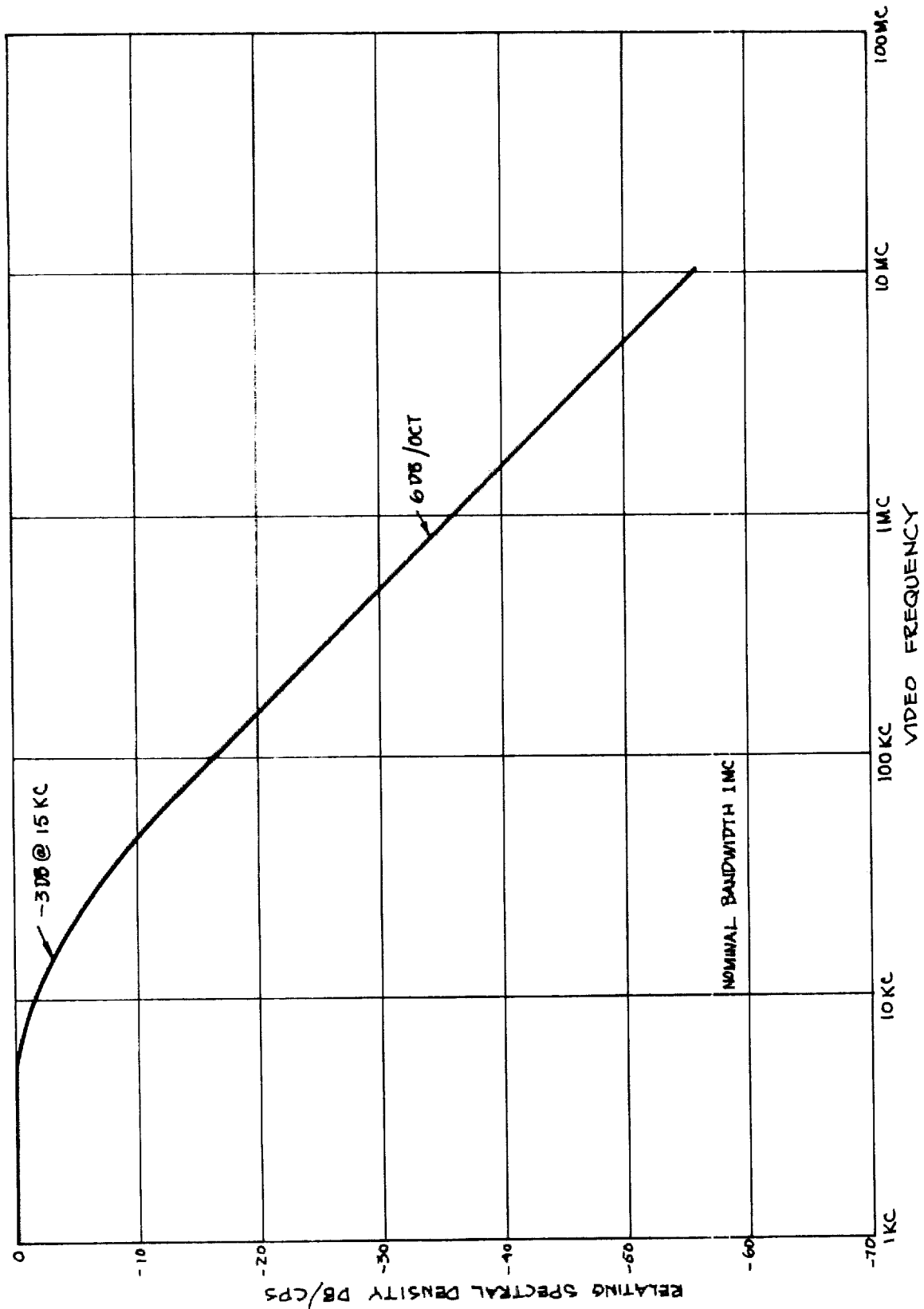

Fig. 4-48 — Estimated S/N in a KC band South Vietnam -
March, 1965

SPECIAL HANDLING

SPECIAL HANDLING

Table 4-12. Summary: Wide Band Link Parameters

Channel	Designation	Frame Duration Seconds	TV Lines per Second	TV Lines per Frame	Nominal Base Bandwidth	Spectrum	S/N Required
A	IR or PHOTO	3.46	1600	5600	3.9 mc	White	46 db
B	HRSIR	24.0	230	5600	1.0 mc	Fig. 4	46 db

SPECIAL HANDLING

SPECIAL HANDLING

Digital Data — The keying data, generated in digital form, consists of the following:

1. processed ELINT data
2. "hot spot" indications from the IR sensor
3. moving-target indications from the HRSLR
4. observer's comments
5. navigation and timing data

The first four types are generated and transmitted at random, interleaved among navigation and timing words, which are transmitted periodically. It is estimated that the random words occur at an average rate of one word per second. A buffer store may be required to smooth the occurrence of bursts of such words. The periodic words are transmitted once in 10 seconds.

Table 4-13 gives the data format for each of these words, and an estimate of the number of bits which must be used.

4.6.3 Narrowband Link

The narrowband link can operate in the HF band (3 to 30 megacycle) using ionospheric reflections or at a higher frequency with a line-of-sight repeater. Because of the relatively low data rate and the desirability of operating this link independently of an airborne repeater, HF operation was chosen with sky-wave reflections from the F2 layer of the ionosphere. The actual frequency selection depends in a complex way on:

1. A complete path description.
2. Geographical location of the transmitter and receiver.
3. Phase of the solar cycle.
4. Season of the year.
5. Time of day.

In addition, since the sky-wave path via the ionosphere is characterized by parameters which are random variables, the problem is approached on a statistical basis, and the communication reliability is stated as a statistical function. Methods and data (see references 6, 7 and 8) for predicting HF

SPECIAL HANDLING

Table 4-13. Digital Data Format

Data Type	Word Identifier	Information Type	Bits	Time of Intercept	Navigation		Cross-Range Location	Spare Bits	Total Bits	Average and rate/second
					Least Sig. Lat	Bits Long				
ELINT	3 bits	Emitter Type	5	10 bits	8	8	10 bits	6	50	0.33
Hot Spot		Temp.	6					5	50	0.33
MTI		Speed & Dir.	7+4					0	50	0.33
Observer's Comments		Observ.	10					1	50	1/60
Coarse Navigation		Navig.	44						44	0.1
Coarse Timing		Timing	16						16	0.1

SPECIAL HANDLING

SPECIAL HANDLING

propagation and noise characteristics have been developed at the National Bureau of Standards and need to be applied on an hour-by-hour basis for a specific situation.

For the sake of illustration, a representative set of circumstances is assumed and the link performance computed. The conditions and assumptions are:

Path length	300 nautical miles
Path location	South Vietnam (midpoint of path at 13°30'N and 108° OOE)
Time period	March 1965
Airborne transmitter	
Transmitter power	100 watts
Transmitting antenna gain	0 db
Transmitting antenna efficiency	15 percent at 2.5 megacycle 55 percent at 7.0 megacycle
Absence of manmade interfering signal	
Receiver (near sea level)	
Receiving antenna	Half-wave dipole at the height for maximum gain
Receiver sensitivity	Limited by external noise

The resulting S/N ratio at the receiver is plotted for a 1 kilocycle bandwidth for a 24 hour period (Fig. 4-49). For this example the optimum traffic frequency (FOT) is 7.0 megacycle during the daylight hours and 2.5 megacycle at night. Figure 4-49 is applicable only for the path length of 300 nautical miles. Since HF propagation is markedly dependent on path length, it may be necessary to change frequencies even during a relatively short mission of an hour or less.

The example chosen here is a particularly difficult one because of the high incidence of thunderstorms in South Vietnam in the early spring gives rise to severe atmospheric noise conditions.

SPECIAL HANDLING

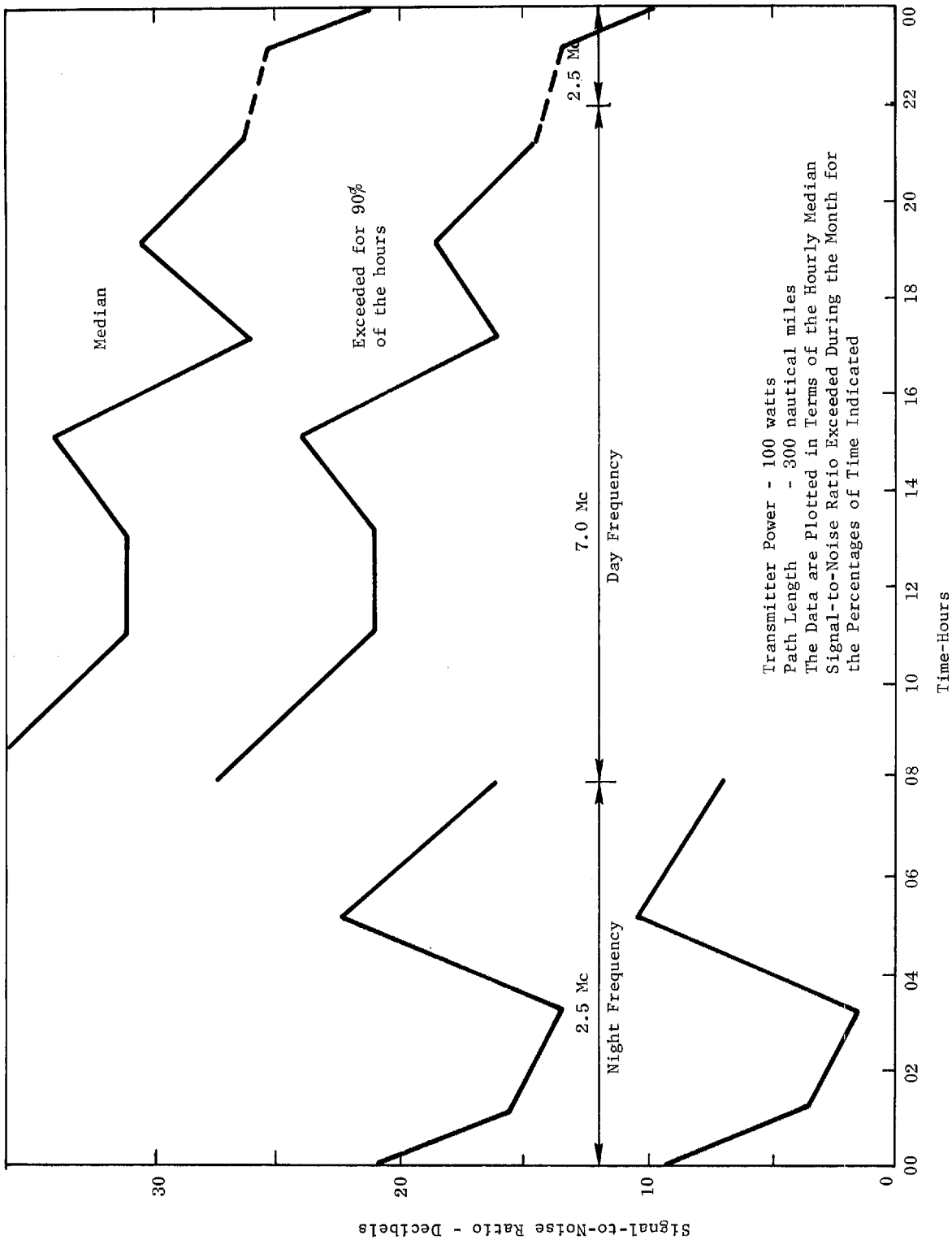

Fig. 4-49 — Estimated S/N in a 1 KC Band-South Vietnam—March 1965

SPECIAL HANDLING

SPECIAL HANDLING

Consider now the error rate performance of a digital data link operating under the specified conditions within a voice channel of a single sideband transmitter. Assume a 75 bit per second data rate and the use of frequency shift keying (FSK) modulation. For this narrower data bandwidth the S/N ratio of Fig. 4-49 must be increased by 6 db. In addition, assume a dual frequency diversity within the same 4 kilocycle voice channel to provide communications redundancy and combat selective fading. Under these conditions a bit error rate of 10^{-4} or less is achieved throughout the 24 hour period for the median curve.

However, when the lowest decile of hourly S/N's is examined, the need for some further improvement is indicated. Several approaches can be used simultaneously. Because the early morning (01 to 04 hours) drop in S/N is not coincident with the occurrence of the minimum FOT, the selection of a higher frequency than 2.5 megacycle would result in lower atmospheric noise, and a better S/N for 01 to 04 hours. Also, an additional diversity can be provided to the system by the addition of another HF transmitter to repeat the narrowband data. So long as the repetitions are separated in time by one second or greater there will be no correlation in the atmospheric noise effects which dominate the hours of interest here.

It is estimated that by using the indicated frequency diversity all of the time, and the time diversity as well as a third transmitting frequency for the early morning hours, the overall system performance will give fewer than 10^{-4} bit errors for 20 hours of the day, and for 90 percent of the early morning hours under the severe atmospheric noise conditions for the assumed mission in South Vietnam.

4.6.4 Wideband Link

The system engineering procedure for the wideband link begins with the selection of an rf band, then the design of a multiplexing-modulation combination, and finally, an estimation of system performance. The details of this procedure are described in detail in Sections 4.6.4.1, 4.6.4.2 and 4.6.4.3, respectively. Table 4-14 is a summary of the results of the wideband link design study.

SPECIAL HANDLING

Table 4-14. Wideband Link Characteristics Summary

Primary Mode of Operation	Delayed Transmission
Airborne Transmitter	60,000 feet-altitude
Carrier Frequency	C-Band (5 gigacycle)
Antenna Gain	12 db
Multiplexing	Frequency Division at rf
Modulation	Frequency Modulation of 2 rf carriers by the 2 analogue data channels
Total RF Bandwidth	46 megacycle
Total RF Power	1 watt
Sea Level Receiver	
Range	240 nautical miles
Antenna Gain	46 db
Front End	Uncooled Parametric Amplifier
System Noise Temperature	326°K
RF power margin for meteorological losses and fading at low elevation angles	9 db
Demodulated signal quality with margin expended, $20 \log \left(\frac{V_{PP}}{V_{rms}} \right)$	46 db

SPECIAL HANDLING

4-163

SPECIAL HANDLING

Briefly considering the multipath problem, the receiving antenna has a half-power beamwidth of approximately 0.8 degrees, and its main lobe is down 6 db at a point about 1.1 degrees from the boresight. For antenna elevation angles greater than 1.1 degrees, the signal fading due to destructive interference between the direct ray and the reflected ray of the received signal cannot depress the signal level by more than 6 db. Therefore, a 6 db fade margin is sufficient to provide for operation down to 1.1 degrees elevation. Likewise, other multipath problems such as frequency perturbations are not significant above this angle and such system sophistication, as diversity reception, is not yet required. Fortunately, the 1.1 degree angle corresponds to a range of 252 nautical miles which is greater than the design range of 240 nautical miles.

Each of the techniques explicitly (and components implicitly) chosen in this design is feasible. A vast amount of experience exists in the design, development and operation of the selected circuit techniques, in spite of the scarcity of operational experience for this system application. The results of this study indicate that the required data link equipment does not pose any technological problems which require separate exploratory programs. However, many design and development problems do await the hardware designer.

4.6.4.1 Wideband Link Frequency Selection

The selection of the radio frequency for the wideband data link under consideration is of fundamental importance. The discussion which follows considers primarily the technical parameters involved in such a selection.

For the wideband link, the relative merits of the UHF band (300 megacycle to 3 gigacycle) and the SHF band (3 to 30 gigacycles) is first considered. The lower portion of the UHF band does not offer sufficient bandwidth capability, and the extrapolated future needs of military data links are such that even S-band (around 2 gigacycles) may not be adequate. Therefore, for the sake of technological compatibility with receiving equipment likely to be contemporary with this data link, the UHF band is dropped from further consideration.

SPECIAL HANDLING

In the SHF band, portions of three sub-bands are of current interest:

1. 4.4 to 5.5 gigacycles in C-band
2. 7.4 to 8.4 gigacycles in X-band
3. 14 to 18 gigacycles in K_u -band

Above K_u -band frequencies, atmospheric attenuation becomes so severe that long range wideband links may not be feasible.

The performance of data links in these three bands is now compared in terms of the S/N ratio at a remote receiver, for a fixed transmitter power. The following system parameters are assumed:

Airborne Transmitter

RF Power	1 watt (0 dbw)
Antenna Gain	12 db
Coupling Losses	2 db
Altitude	60,000 feet

Sea Level Receiver

Range	240 nautical miles
Receiving Antenna	16 foot parabola

The signal power at the receiver is then given by:

$$P_R = P_T - L_C + G_T - L_P - A_T - A_C - A_P + G_R$$

where

P_R = receiver power, dbw

P_T = transmitter power, dbw

L_C = coupling losses in the transmitter, db

G_T = transmitting antenna gain, db

L_P = free space loss, db

SPECIAL HANDLING

4-165

SPECIAL HANDLING

A_T = attenuation due to oxygen and water vapor along the atmospheric path, db

A_C = attenuation due to the condensed water droplets in clouds along the path, db

A_P = attenuation due to precipitation along the path, db

G_R = receiving antenna gain, db

A summary of the P_R computations is given in Table 4-15.

Table 4-15. Signal Power at Receiver, P_R , for
Three Frequency Bands

Band	f Gc	P_T dbw	L_C db	G_T db	L_P db	A_T db	A_C db	A_P db	G_R db	P_R dbw
C	5	0	2	12	159.3	1.3	0.9	0.2	46	-105.7
X	8	0	2	12	163.4	1.5	1.4	0.7	50	-107.0
K_u	16	0	2	12	169.4	2.0	5.0	3.4	56	-113.8

The first two loss factors (L_C and L_P) in the table, are straight-forward computations. The factor A_T (see reference 9) is relatively uniform and static for the frequencies considered here. A_C has been computed (see reference 10) for an extensive cloud cover (associated with frontal zones) in the temperature zones. The db values indicated can get to be about three times greater under high humidity conditions, therefore, operating margins of 1.8, 2.8, and 10 db should be considered for C, X, and K_u -bands, respectively, to ensure the required performance.

A_P has been computed to account for 99 percent of the hours in a temperate zone (see reference 10), where greater communications reliability is required, or in areas of greater precipitation, these figures must be raised accordingly.

SPECIAL HANDLING

The noise performance of the receiver is dominated by the ENT (equivalent noise temperature, °K) of the external environment as viewed by the antenna, and by the ENT of the receiver front end. Some interesting cases are tabulated in Table 4-16.

Table 4-16. Receiver Noise Temperatures for
Three Frequency Bands

Band	Noise Temperatures ENT (°K)				Total Noise Temperatures ENT(°K)			
	A Antenna At Sea	B Antenna On Land	C Receiver Parametric Amplifier	D Receiver Cryogenic Maser	A+C	A+D	B+C	B+D
C	126	153	200	6	326	132	353	159
X	129	154	290	7	419	136	444	161
K _u	152	172	440	9	592	161	612	181

In calculating the antenna temperatures in Table 4-16, the antenna sidelobe characteristics assumed are for an "average" antenna, not for one with suppressed sidelobes designed specifically for low noise operation (see references 11 and 12). It is felt that this more nearly describes the actual situation.

Although both a parametric amplifier at 290°K and a maser at liquid helium temperature are considered here, the difficulty of operating the cryogenic maser under field conditions precludes its use in most situations.

Continuing with the evaluation, the S/N ratio for each frequency band is computed for a 1 cps bandwidth, and the 1 watt transmitter power. However, since the shipborne receiver is of greatest interest here, only the noise temperature of column (A+C) from Table 4-16 was used. The S/N ratios are tabulated in Table 4-17.

SPECIAL HANDLING

4-167

SPECIAL HANDLING

Table 4-17. Resulting Receiver S/N Ratios
Three Frequency Bands

Band	P_R (dbw)	P_N (dbw/cps)	S/N (db)
C	-105.7	-203.4	97.7
X	-107.0	-202.3	95.3
K_u	-113.8	-200.8	87.0

For the assumed conditions, the C-band link is 2.4 db more efficient than the X-band link, and 10.7 db better than the K_u -band link. When one adds the safety factor required for clouds, these figures become 3.4 db and 18.7 db, respectively. Another consideration is that greater rf power is available at C-band than at the other two bands. Therefore, from a technical point of view, the C-band link is the best, with X-band a fairly close second, and K_u -band a poor third. However, such other considerations as a pre-emptive frequency allocation, an electronically-steerable high-gain antenna for the reconnaissance aircraft, and ultrawideband data requirements could force these results to be reshuffled.

4.6.4.2 Wideband Link Multiplexing - Modulation Techniques

In engineering the wideband data link, the selection of a multiplexing-modulation technique is secondary in importance only to the selection of the rf carrier. The characteristics of the individual data channels handled by this link are discussed in Section 4.6.2. In the following discussion, various techniques are considered, and their relative merits judged on the basis of their contribution toward the goal of reducing the required transmitter power while achieving the specified signal quality. The fundamental tradeoff applied here is that of increased bandwidth for reduced transmitter power. Of course, for the sake of system feasibility, this tradeoff is bounded by what is realizable in such areas as modulation linearity, accurate and high rate signal sampling, and so forth.

SPECIAL HANDLING

At the transmitter terminal of a data link the modulator is usually preceded by the multiplexer which reduces the system hardware. However, when a component becomes exceedingly difficult to build, or unfeasible because of the wideband requirements imposed by this approach, a greater number of less difficult components may offer the better solution. This tradeoff of more hardware for better performance is applied wherever it removes a stumbling block from the successful conclusion of the data link design.

The broad categories of techniques (see reference 13) considered here are as follows:

- | | |
|---------------------|---|
| Baseband Techniques | <ol style="list-style-type: none">1. Vestigial Sideband (VSB)2. Digital Subcarriers (DSC)3. Pulse-Code Modulation (PCM) |
| Multiplexing | <ol style="list-style-type: none">1. Time-Division (TDM)2. Frequency-Division (FDM) |
| Modulation | <ol style="list-style-type: none">1. Frequency (FM)2. M'ary Frequency-Shift Keying (M'FSK)3. Phase-Shift Keying (PSK) |

The baseband techniques are those required to prepare the baseband signals for the multiplexing and modulation processes. The analog channels are derived from scanned images. Typically for these data, the low frequency components (down to dc) are important; to preserve image quality these should not be removed or distorted. Whenever it becomes necessary to shift the baseband spectrum of a video signal, the VSB technique is used to minimize the bandwidth without seriously affecting image quality.

Similarly, when digital signals are to be frequency-multiplexed with non-coherent signals, or time-multiplexed with other pulse trains, it is often desirable to shift their spectra or gate them into correct time sequence, by mixing the digital signal with a higher frequency digital subcarrier. We refer to this process as DSC.

SPECIAL HANDLING

4-169

SPECIAL HANDLING

Furthermore, to convert an analog signal into a digital signal, the PCM technique is used here. While the previous two processes approximately preserved the base bandwidth, the PCM technique multiplies the bandwidth by two factors: 1) the number of samples per cycle, and 2) the number of binary digits per sample.

Time-division multiplexing (TDM) interlaces digital data pulses from different channels such that the channels occupy the same bandwidth, but are separable in time. Frequency-division multiplexing (FDM) is a method whereby individual channels are added together to form a composite signal. In order to permit separation of those signals, they are each assigned to a separate frequency band.

Frequency modulation (FM) is considered here in preference to other methods of carrier modulation by an analog signal, because it permits a significant and efficient increase in rf bandwidth occupancy, with a subsequent reduction in transmitter power requirements.

For digital data, a choice must be made between phase-shift keying (PSK) and M'ary frequency-shift keying (M'FSK, sometimes referred to as multi-frequency tone signaling). It can be shown that relative to PSK, an M'FSK signal uses wider bandwidth, requires less transmitter power, and simultaneously increases the length of the signaling elements. The latter two characteristics are highly desirable in wideband data link applications. However, the principle, that of increasing hardware for the sake of easing the technical problems, has been stated. The M'FSK is tentatively chosen over PSK for this application.

The tasks remaining is the consideration of the foregoing techniques in various combinations, and the selection of that combination which is both feasible and theoretically most efficient. These combinations (wideband data link concepts) are shown in Figs. 4-50 through 4-54.

The combination in Fig. 4-50 is the straight-forward analogue approach commonly used in microwave relay links. For wideband signals the non-linearities in the FM modulator, and in the receiver's discriminator, impose a bound on the amount of FM improvement in signal-to-noise ratio which the system can achieve through wide frequency deviation.

SPECIAL HANDLING

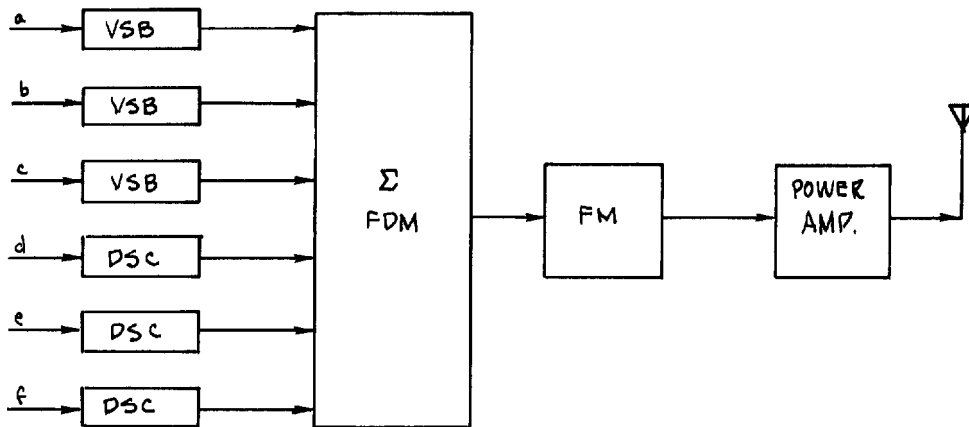

Fig. 4-50 — Multiplexing-modulation technique (straight-forward analogue).

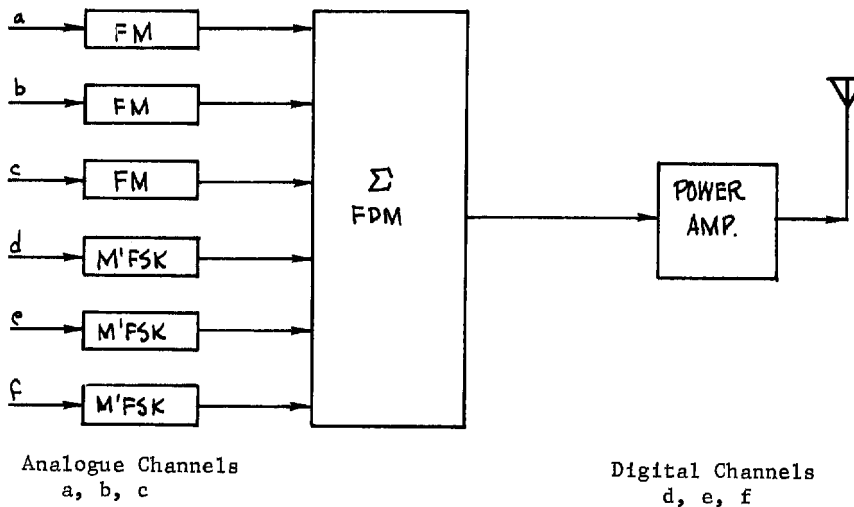

Fig. 4-51 — Multiplexing-modulation technique (multiple RF carriers).

SPECIAL HANDLING

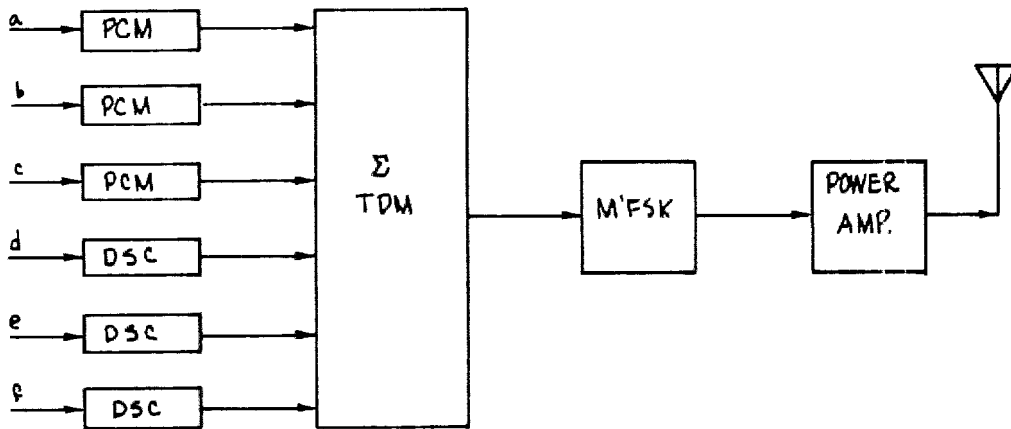

Fig. 4-52 — Multiplexing-modulation technique (straight-forward digital).

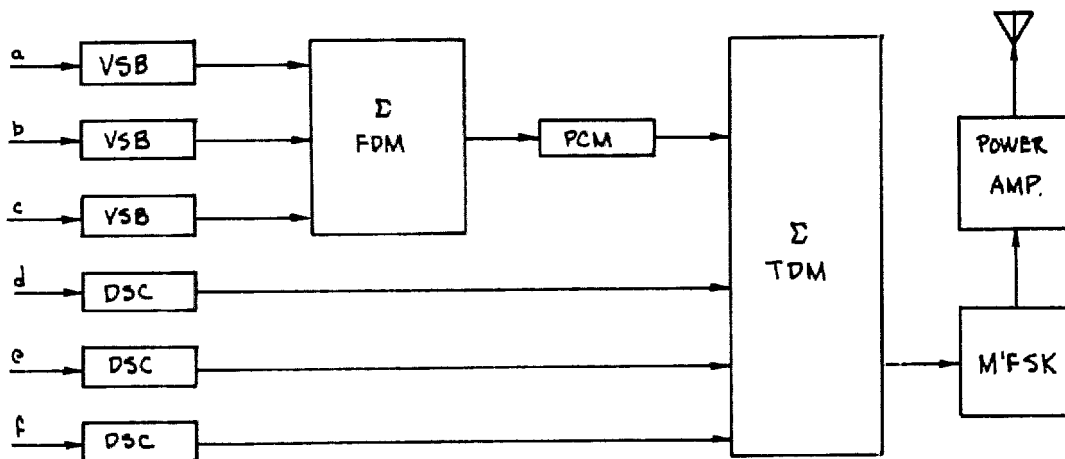

Fig. 4-53 — Multiplexing-modulation technique (hybrid analogue digital).

SPECIAL HANDLING

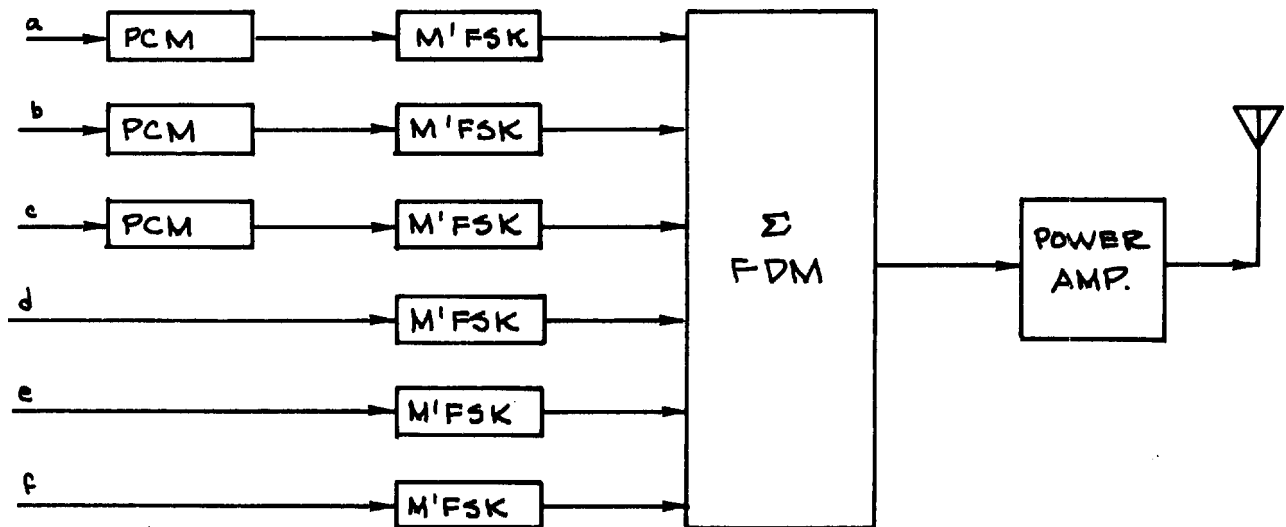

Fig. 4-54 — Multiplexing - modulation technique (multiple digital transmitters).

SPECIAL HANDLING

The approach in Fig. 4-51 circumvents this difficulty by assigning an individual modulator to each analog channel and an orthogonal set of frequency tones to each of the digital channels. These are then frequency multiplexed at rf to form a composite signal which is amplified by a wideband linear amplifier, like a TWT, and transmitted.

The combination in Fig. 4-52 is a straight-forward digital approach, in which each of the analog signals is digitized directly and interlaced with the other digital signals. The composite pulse train is then coded and the appropriate multi-frequency tones are keyed, amplified, and transmitted. For wide bandwidths the time-multiplexed code elements become as short as a few nanoseconds and, therefore, become difficult to handle. This problem is not as critical in the M'FSK circuit, since several short code elements are combined to give longer output pulses.

Figure 4-53 shows a variation of Fig. 4-52 in which the analog signals are first frequency-multiplexed to produce a composite wideband signal. This signal is converted to PCM by a high-speed sampler/digitizer. This PCM signal is combined with the other digital signals and processed by the M'FSK coder, amplified, and transmitted. This approach time-shares the PCM equipment among the three analog channels and, thereby, compounds the difficulty of converting wideband analog signals to nanosecond pulse digital signals. Although an apparent equipment saving has resulted, the high-speed digitizing required may be beyond the state-of-the-art.

Another variation of Fig. 4-52 is seen in Fig. 4-54. Here each analog channel is individually digitized and multifrequency coded for transmission. Although this approach uses more hardware than the others, it also permits the greatest frequency spreading, and uses the longest duration signaling elements. With microminiaturization, the additional hardware may not be a significant disadvantage. The independence of each channel represents a desirable system redundancy, and permits greater system flexibility, which is true for the system in Fig. 4-51.

Finally, the choice must be made between Figs. 4-51 and 4-54. This should be made on the basis of analog signaling, versus digital signaling. Should the

SPECIAL HANDLING

requirements for secure communications be imposed on the data link, the choice would be clearly for the digital system. On the other hand, the techniques employed in Fig. 4-51 have had significantly more trial in operational systems. From a theoretical viewpoint, Fig. 4-54 offers the greatest potential reduction in transmitter power, especially if higher signal-to-noise ratios are required. Furthermore, a close examination of the technique employed in Fig. 4-54, indicates that the circuit techniques are well developed in spite of the fact that little operational system experience is available.

This qualitative discussion of the relative merits of these multiplexing-modulation combinations can only serve as general guidelines in the preliminary selection of system techniques. In Section 4.6.4.3, the evaluation of some of these multiplexing-modulation combinations is carried out specifically for the data channels of interest.

4.6.4.3 Wideband Data Link Performance

In this section, the transmitter power required by the data link is computed. Preparatory to this, detailed computations are done for the performance of the multiplexing-modulation approaches discussed in the previous section. Since the digital signals (channels d, e, and f) occupy a relatively insignificant bandwidth, they are not included in these analyses for the sake of simplicity. The following conditions are assumed:

Path Length	240 nautical miles
Airborne Transmitter	
Transmitting Antenna Gain	12 db
Carrier Frequency	5 gigacycles
Losses from Transmitter to Receiver	164 db
Loss Margin	8 db
Receiver (near sea level)	
Receiving Antenna	16 foot parabolic - 46 db gain
Receiving System ENT	326°K

SPECIAL HANDLING

4-175

SPECIAL HANDLING

Receiver Noise Power	-203 dbw/cps
Data Channels	See Section III A

For the system shown in Fig. 4-50, two arrangements of the two channels in the frequency-division multiplex are possible. Both were evaluated, and the arrangement with channel a (IR composite signal) at the low frequency and channel b at the higher frequency, minimizes the required power. For this arrangement emphasis networks were designed (see reference 15) to further reduce the carrier power required to attain the 46 db signal-to-noise ratio.

In commercial TV, subjective tests have shown that interference by a low-frequency tone (or low-frequency, narrow-band noise) is much more disconcerting than interference by a high-frequency tone of equal power. This has led to the use of noise weighting functions which rate low-frequency noise more disturbing than high-frequency noise. However, for a reconnaissance application, the key requirement is the preservation of fine detail, and slight large-area distortions in the picture do not reduce the value of the data. Therefore, in the emphasis network optimization procedure, a uniform noise weighting function was used.

Next, the peak frequency deviation required for each channel was computed, as the means for allotting the optimum carrier power to each channel. Finally, the required transmitter power was computed. This design is summarized in Table 4-18.

For the system shown in Fig. 4-51, each channel frequency modulates its own rf carrier. Each of the channels is treated individually in the design of channel emphasis, peak deviation, and carrier power, with due respect to the full improvement threshold signal-to-noise ratio of the receiver. A summary of this design follows in Table 4-19.

For the system of Fig. 4-52, each analog channel is converted to a PCM format. To reduce the quantization noise (assumed to be "white") introduced by the digitization process, emphasis is applied to the signal spectrum prior to sampling (see reference 15). For channel b, 13.7 db improvement is obtained. This is equivalent to greater than 2 bits of quantization. To meet the 46 db quality requirement, a 6-bit quantization would ordinarily be needed, but the

SPECIAL HANDLING

Table 4-18. Transmitter Power Required -
Modulation System B-1

Channel	Base Bandwidth	FDM Band	Peak Deviation	Emphasis Improvement	RF Bandwidth	Trans. Power Required
a	4 mc	0 to 4 mc	± 18 mc	1.2 db	—	—
b	1 mc	4 to 5 mc	± 4.7 mc	13.7 db	—	—
Total	—	0 to 5 mc	± 18.6 mc	—	45 mc	27.5 dbm 563 mw

Table 4-19. Transmitted Power Required -
Modulation System B-2

Channel	Base Bandwidth	Emphasis Improvement	Peak Deviation	RF Bandwidth	RF Power
a	4.0 mc	1.2 db	± 18 mc	44 mc	550 mw
b	1.0 mc	15.5 db	± 2 mc	6 mc	28 mw
Total	—	—	—	50 mc	578 mw = 27.6 dbm

SPECIAL HANDLING

4-177

SPECIAL HANDLING

emphasis allows this to be reduced to 4 bits. A word of caution at this point; the assumption that quantization noise is "white" becomes questionable for such a coarse quantization level, so that experimental verification of the actual effects of emphasis and 4 bit quantization is desirable before proceeding to design operational hardware. For channel a, no improvement is obtained by emphasis, because both the signal and noise spectra are assumed to be "white" and, therefore, already matched to each other.

A sampling rate of 3 times the maximum frequency of channel b, and of the subchannels of a, was chosen. A value as low as 3 samples per cycle, under these circumstances, does not introduce excessive biasing or distortion errors, because the signal spectrum at the nominal band cutoff is conservatively estimated to be 36 db below the power level of the low-frequency spectrum. For the typical TV spectrum, it is 57 db down. Therefore, it is estimated that, using a 4-section Butterworth filter for post-decoding interpolation, the processing error (see reference 16) at this sampling rate will be below the noise level when the 46 db picture quality level is achieved. The use of emphasis networks does not alter these estimates significantly, because the additional high-frequency errors, thereby introduced, are attenuated by the de-emphasis network. The resulting PCM parameters are summarized in Table 4-20, and the rf requirements for a PCM/PSK transmitter are also included for a bit error probability of 10^{-4} .

Taking the output of the TDM (Fig. 4-52) in which the PCM signals are encoded in 5-bit blocks, we generate a pulse at one frequency, out of a possible 32 frequencies, for each 5-bit block. This constitutes a 32-level M'FSK encoding. The signaling element length is thereby reduced by a factor of 5, and the total rf bandwidth is increased by a factor of 6.4 over PCM/PSK (see reference 17). The M'FSK characteristics are given in Table 4-21 for a bit error rate of 10^{-4} .

A summary of the rf power required for the four optimized system designs considered here is:

FDM/FM (System B-1)	27.5 dbm	0.56 w
2-Carrier FM (System B-2)	27.7 dbm	0.59 w
PCM/PSK (System B-3)	29.7 dbm	0.93 w
PCM/M'FSK (System B-3)	27.2 dbm	0.53 w

SPECIAL HANDLING

Table 4-20. Transmitted Power Required -
Modulation System B-3 (PCM/PSK)

Channel	Base Bandwidth	Emphasis Improvement	Samples Cycle	Bits/Samples	Bits/Second	PCM/PSK	
						RF Bandwidth	RF Power
a	4 mc	0 db	3	6	72 mbps	—	—
b	1 mc	13.7 db	3	4	12 mbps	—	—
Total	—	—	—	—	84 mbps	126 mc	29.7 dbm = 930 mw

Table 4-21. Transmitted Power Required -
Modulation System B-3 (PCM/M'FSK)

Frequency tones	32
Frequency pulses/second	16.8 mbps
M'FSK rf bandwidth	813 mcps
Rf power required	525 mw = 27.2 dbm

SPECIAL HANDLING

4-179

SPECIAL HANDLING

Using rf power as the figure of merit, leads to the selection of the PCM/M'FSK approach. However, since all of the above rf powers are well within the reach of practical airborne C-band power amplifiers, this criterion becomes less important, and other norms must be applied. The 2-carrier FM system has the fewest number of circuit blocks, is the least critical in terms of component linearity, has the greatest flexibility and is well within the state-of-the-art. Therefore, the 2-carrier FM system is the approach recommended for this data link design. The keying data can be easily inserted as a third carrier or as a digital subcarrier multiplexed with channel a after the emphasis network.

SPECIAL HANDLING

REFERENCES

1. G.C. Higgins, "Methods for Engineering Photographic Systems," Vol. 3, p. 1, Applied Optics, 1964.
2. D.G. Fink, "Television Engineering," p. 26, McGraw-Hill Book Company, Inc., New York, 1952.
3. D.G. Fink, op cit., p. 32.
4. D.G. Fink, "Television Engineering Handbook," p. 10-22, McGraw-Hill Book Company, Inc., New York, 1957.
5. D.G. Fink, op cit., p. 256.
6. G.W. Hayden, D.L. Lucas, and R.A. Housen, "Technical Considerations in the Selection of Optimum Frequencies for High-Frequency Sky-Wave Communication Services," N.B.S. Report No. 7249, 1 November 1962.
7. "Ionospheric Predictions for March 1965," N.B.S. Report No. 24, December 1964.
8. CCIR Report No. 65, Los Angeles, 1959.
9. D.C. Hogg, "Effective Antenna Temperature due to Oxygen and Water Vapor in the Atmosphere," pp. 1417 to 1419, Journal of Applied Physics, Vol. 30, No. 9, September 1959.
10. W. Holzer, "Atmospheric Attenuation in Satellite Communications," pp. 119 to 125, Microwave Journal, March 1965.
11. R.C. Hansen, "Low Noise Antennas," pp. 19 to 24, Microwave Journal, June 1959.
12. R. Gardner, "Antenna Noise Temperature Study," Final Report 3304-11 on Contract DA-49-1 70-SC-1547, Airborne Instruments Laboratory, November 1957.
13. H.S. Black, "Modulation Theory," D. Van Nostrand Co., Inc., 1953.
14. E.J. Baghdady, "Lectures on Communication Theory," McGraw Hill Book Company, Inc., New York, 1961.

SPECIAL HANDLING

SPECIAL HANDLING

REFERENCES (Cont.)

15. R.A. Bruce, "Optimum Pre-Emphasis and De-Emphasis Networks for Transmission of Television by PCM," pp. 91 to 96, IEEE Transactions on Communications Technology, September 1964.
16. D.G. Childers, "Study and Experimental Investigation on Sampling Rate and Phasing in Time-Division Telemetry Systems," pp. 267 to 283, IRE Trans. on Space Elect. and Telemetry, December 1962.
17. V.A. Kotelnikov, "Optimum Noise Immunity," pp. 48 to 52, McGraw Hill Book Company, Inc., New York, 1959.

SPECIAL HANDLING

4.7 DATA MANAGEMENT

Background

"General-purpose display consoles, which were originally developed to facilitate the man-machine interaction in command and control information systems, have not found wide acceptance and use in this application. Instead, the greatest success in the use of general-purpose display consoles has occurred in scientific applications.

Early in 1958, in what was then the Ramo-Wooldridge Corporation, the Data Systems Project Office design team was faced with the problem of designing a man-machine subsystem to aid in the analysis and interpretation of large quantities of reconnaissance data. Proper interpretation could be done only by correlating new data with older data contained in a large, highly structured computerized data base. Both men and machines were required in the interpretation. The computer could be programmed easily to perform routine data-conversion and filekeeping functions, and to perform rough file selection for data correlation; however, the analyst was essential for the final interpretation. A rapid means for displaying data and for recording the analyst's interpretation were required. Also, since they had to perform other system control functions as well as interpretation, the analysts in the system needed current information on the state of the system itself, and the system needed a facility for accepting instructions from the analysts.

The solution which was adopted was that of developing a general-purpose display console (called the Display Analysis Console) to function as a man-system interface. The console (the forerunner of the Bunker Ramo TRW 85 console) could display graphical and alphanumeric data, and had capability for input of data from the analyst

SPECIAL HANDLING

4-183

SPECIAL HANDLING

using control keys, crosshairs, and light pen. A time-shared digital computer, the TRW 400, was intended in the system design to serve to format the output displays, and to operate subroutines in response to user inputs.

Since the same console was to perform many different tasks, the meaning of the console keys could be changed by overlays on the keyboard, just so long as the computer was appropriately informed, by a coded input, as to which subroutines were to be used. Since programs could be changed more easily than hardware, a system designed in this way could readily be adapted to changing needs.

We thought that we had solved the problem, and that general-purpose consoles and this system philosophy would find extensive use in command and control or other man-machine information systems in which large data bases were involved and displays were essential.

This has not occurred. It is now nearly seven years later, and general-purpose consoles, although effective in particular military applications, are not widely used and are not used with the versatility that was originally envisioned. It turned out that the equipment design philosophy was good and fit the user-machine interface very well. However, nobody has been able to implement an information system using general-purpose consoles such that programs allow sufficient flexibility to meet actual and changing requirements of the operating systems.

Some of the desired capabilities for a general-purpose display system are:

- . simplicity — the system should be easy to use for non-programmers;
- . a language for accessing (retrieval and storage) data in a data base;

SPECIAL HANDLING

- compatibility with a wide class of data bases, requiring only that the data base be described properly to the system;
- full arithmetic and logical manipulative capability;
- on-line programming capability;
- capability for accepting inputs from different types of devices, e.g., keyboard, light pen, and RAND Graphic Input Tablet;
- output on CRT display (alphanumeric and line drawing), teletype, line printer, and plotter;
- ability to interface with other programs and to operate within a time-sharing environment; and
- provision for supplying cueing and prompting information flexibly to the user."

— from SP-1688 - S.D.C.,

General-Purpose Display System,

23 September 1964

SPECIAL HANDLING

4-185

SPECIAL HANDLING

SPECIAL HANDLING

SPECIAL HANDLING

4.7.1 Introduction

The multisensor concept as put forth here, takes note of the inherent difficulty in the proper maintenance of the man/machine interface in a dynamic, flexible system as is required in an operational task force. The varied task force assignment or mission spectrum presents a unique problem, for which there may be no unique answer. In evaluating all the vast data manipulation concepts available in modern technology, it has been decided that the emphasis must be placed on man aids, rather than replacements. This has been done for the purpose of manual back-down when required, and with the realization that the man alone is the most adaptive and flexible means of maintaining continuity in a tense, time restricted environment. The broad concept which will be discussed is shown in Fig. 4-55.

The multisensor system records are more extensive over a time base, than the returns from other reconnaissance systems. By their nature, there are redundant records of the same targets and areas from several sensor types to be maintained. In addition, a viewer must be provided which allows correlative viewing of any of the prime records, and the reference imagery. In order that the viewer provide flexibility, and utilize the keys, a concept is presented which permits viewing of two prime records and two reference records, while maintaining up to ten switchable parallel channels in the viewer. The records can be slewed and are controlled by the time reference from the key tape, and the corresponding data blocks on the imagery. The wide spectrum data collection system has been evolved on the basis that technical detail, such as identification of 37 versus 57 millimeter artillery may be requested at any time, and further, that a sortie may be required to collect from various altitudes, thus requiring full spectrum onboard capability.

4.7.2 Data Reduction

In the system evaluation between adaptive data collection and adaptive analysis, the conclusion reached in this study has been overwhelmingly in favor of analysis.

In explanation, there is a need to collect sufficient detail, at the time of original cover, to allow for technical determinations which may be pertinent to

SPECIAL HANDLING

4-189

SPECIAL HANDLING

the tactical situation, such as weapon caliber. This need implies detail not normally required for tactical status reconnaissance. Further, there is implicit in the flexibility of a task force a requirement for a wide spectrum sensing capability, in that the sortie profile may range over many extremes. The airborne sensors, and data management systems, must have an inherent ability to deal with combat and peaceful missions, and with a variety of information needs within a sortie framework. Thus, the justifications for decision must rest on these basic requirements, realizing that attendant to the operational environment must be the knowledge that little time is available to make physical changes to the system in a dynamic situation.

The attendant problems of selective sensing appear complex beyond the needs of the problem. The basic tenet of selectivity is an ability to automatically locate and identify a target as requiring coverage. This implies that the reconnaissance task has been virtually completed just in the collection. There is considerable doubt that any automatic sensing system could cope with the false alarm rate which would be a part of such a system in order that it avoid missing borderline information. Rather, it seems logical to collect more information, and look at it less. To accomplish this the automatic detection systems are required only to indicate the type and geographical location of a detected or thresholded target. This is well within the capability of the observer and of the IR, SLR and ELINT systems, and virtually impossible for the photographic systems. The keys so generated are designed to place on each record an indication of type and location of alarm, so that the analyst can ignore the mass of information not pertinent to his job. This screening can be referred to as adaptive analysis, in that the major problem of data volume is handled by pinpointing areas of high target probability. This concept is the basis of the data reduction system suggested for the multisensor system.

It has been established that the sensor records will be used as follows:

For priority analysis — a real time function dealing with key alarms and IR and selected photo imagery, for the purpose of evaluating the take of the sortie, and setting up the historical records required for interpretation. The records utilized are:

SPECIAL HANDLING

1. Key alarm indications of IR hot spots, SLR reflective targets and MTI indication and ELINT source
2. Observer/operator reports on visual observation and display evaluation
3. Optional IR imagery forward or vertical
4. Optional selected photo imagery, or video imagery

For interpretive analysis — a function of trained photo analysts, using high quality prime records in concert to provide timely intelligence. The records utilized are:

1. Cumulative key, ELINT and Order of Battle map display with aircraft indicator
2. Observer reports
3. Prime aircraft records, which may include:
 - 7 photographic records
 - 2 IR records
 - 1 SLR record
4. Historical and reference imagery
5. Reference documents

The principle of adaptive collection has been discussed earlier in this document. The proposed system bases its effectiveness very heavily on principles of adaptive analysis but also incorporates some of the characteristics of adaptive collection.

A sortie is launched having been assigned responsibility for the coverage of up to twenty predesignated targets. The observer is responsible for activating the appropriate sensors to provide the required information. However, those sensors providing data for the keying display must operate and therefore record and transmit during the entire mission. Only the photographic system is activated intermittently on the preassigned targets. Where point targets are assigned, keying the photographs for selective analysis provides only limited benefits. However, a large percentage of the missions are assigned tasks of area,

SPECIAL HANDLING

4-191

SPECIAL HANDLING

route, beach or battle-line surveillance. In this case, limiting analysis to keyed photographs reduces the volume of effort and the time for completion of critical sortie analysis.

Were activation of the photosensors limited to the preassigned targets, implementation of the keying display would not be justified. However, the keying display provides the observer with a category of data permitting him to operate the full range of sensors when he identifies signatures of critical fleeting targets on his display. This element of adaptive collection reduces the probability of overlooking targets, not previously assigned, which fall along the mission route. In addition, the availability of an identical keying display in the command environment permits realistic mission diversion and enables real time command requests for photo system activation.

The data reduction from raw material to intelligence will be accomplished as two distinct operations. The priority analysis will be performed in near real time, the detail analysis will be performed after return of the reconnaissance aircraft. The viewing requirements are distinctly different, and affect the data management concept.

The real time transmission of keying data to the priority analyst and its display on a duplicate of the viewer available to the observer provides an excellent analytic capability to support command decisions on actions to be taken to counter fleeting threats to friendly forces. However, keying data alone may not be sufficient to identify the nature of the target. Lacking these specific data, the commander may hesitate to commit available resources for its destruction until positive identification can be established. The system provides IR imaging for this purpose whose resolution is adequate for target identification. Although best IR image resolution is obtained at low altitude, current detectors make possible the acquisition of imagery from high altitude with sufficient resolution to permit gross target identification. Sensing in the IR frequencies has the added benefit of reduced signal attenuation by atmosphere. The sensed data is electromagnetic and can be transmitted without transduction.

Considering the alternative of using a photographic image to confirm and identify fleeting targets there are two options available.

SPECIAL HANDLING

Number 1 — Airborne processing, and transmitting images preselected on keying data for reconstitution and viewing aboard the carrier. Using this technique imposes considerable equipment and system sophistication and a significant time delay from sensing to analysis.

Number 2 — Selective, instantaneous acquisition of a video image and real time transmission to the carrier where it is recorded and displayed.

The degradation in image quality suffered in option 1 above regardless of the quality of the original image will result in a received image equal in quality to the IR image or the video image, offering nothing more in information while adding to system complexity and delay in analysis. Option 2 offers an excellent backup to the IR image in the event of IR system failure but will not equal the IR system capability in the event of haze or other obscuration to visual image formation. In either case, both IR and video imagery are available in "real time" permitting immediate configuration of targets posing a threat to friendly forces.

4.7.2.1 Priority Analysis

The installation of the priority information channel has been made for the reasons of short time data requirements, as indicated in the operational analysis. The intelligence most useful to a tactical commander, is that which is most up-to-date. In particular, fleeting and transient targets are of high importance, and the information on their location and activity rapidly decays to the point of uselessness in about an hour. This is far less than the normal data reduction time from a reconnaissance mission. In order to extract some value from the real time acquisition/data transmission system, and still not overload the data rates of the analyst, the key display over the current OB status map will be used by the priority analyst.

The viewer then becomes a screen display of the key alarms, operated off a tape recorded from the HF data link in real time. The tape is used to provide the input signals to the electro-optical viewer, which duplicates the observers display already described. It maintains the stop action feature and moving OB map with the aircraft locator superimposed on it.

SPECIAL HANDLING

4-193

SPECIAL HANDLING

In addition, using the carrier computer and a disc storage system, the key and control transmitted tape will be used to generate a cumulative plot of aircraft flight path, and the keys, on a current OB status map.

The correlative use of these displays will allow the analyst to provide the following intelligence.

OB Status — By direct use of the current OB map and correlation with new alarms, fleeting targets and activity from IR and MTI can indicate action areas of high interest. The knowledge of targets in the area could indicate what the hostile intent is, certainly such indications will call up examination of imagery when available to identify the active elements. ELINT detections in themselves constitute OB material, and are part of the key record and available in near real time.

Activity Reports — In parallel with determining gross OB status by correlation, the analyst will be able to indicate areas to be diligently examined for activity of an unknown nature. The MTI, SLR reflection keys plus the IR and ELINT will be supplemented by the observer reports and these will clearly indicate in the cumulative plot, high alarm density areas, with sufficient information to determine OB status.

Alerting for Detail Analysis — As a part of the activity report, the analyst sets up the format for the detail analyst by listing the areas to be covered first, even to the point of pre-empting the sortie target list priority. The communicator for the analyst may draw up a supplementary list of references probably required to support the detail analysis. This information may come from changes in flight path activity or detection of innocuous areas.

To further support these functions of the priority analyst requires some imagery analysis to confirm either the observer's reports; to identify further new alarm areas; and to present visual confirmation on the assigned targets. As noted previously, the photo sensors will be activated on "targets of opportunity" in addition to the assigned targets and there is considerable time to be won on fleeting targets by having some imagery available.

In this respect, it is necessary to provide a priority analyst whose sole function is selected image analysis. This must be in parallel to the real time

SPECIAL HANDLING

work, so that the current situation is covered, as well as the delayed evaluation of imagery. The imagery may be time delayed by minutes due to transmission mechanics, and it will be selected on the judgment of the airborne operator and the priority analyst who are operating in the broad field, and need not stop to evaluate and thus lose new material during the change of attention.

The spot analysis of imagery, whether IR, selected photo, or video, will now form a better basis for OB up-date on fleeting or transient targets, within the useful time range.

The communicator associated with the analysts at the priority station is vital in relieving the need for attention shift from analysis to communication. With the communicator, an oral report by the analyst can be made, without shifting attention even momentarily.

In summary, the priority analysts will view in real time the key display, a duplicate of the airborne system, and selected imagery. Their reports will be oral, and communication with the OB status plot and the rest of the data reduction complex will be through the communicator.

4.7.2.2 Mission Analysis

With the inclusion of the priority analyst in the data reduction system, the job of the detail analysis is eased slightly. Consider the case when the wideband data link has been operative, which is to be the preferred operational mode. The time pressure on the detail work is relieved in that the short term information has either been utilized or has now decayed, thus allowing the first through the records to be a working run, not a frantic search for some hidden major threat.

The analyst now will utilize the prime records of the flight. In detail they are comprised of the following items.

1. Photographic imagery, in the processed transparent positive, with the negative available.
2. IR imagery, as transparent processed positive, and a magnetic tape with full detail as back-up.
3. SLR imagery, as a transparent positive, prepared on the carrier from a transmitted non-image film record. A high resolution positive will be produced

SPECIAL HANDLING

SPECIAL HANDLING

15 minutes after the return of the aircraft.

4. Key and Control record, a magnetic tape carrying key annotations, observer report, navigation data, and time record.

5. ELINT record, as a magnetic tape, not to be used in interpretation as the ELINT information is already on the key record. The tape will be processed for emitters outside the set 20 already programmed on the aircraft.

These records will be in numbers governed by the sortie profile. For a low level sortie there will be five maximum photo records, two IR, one SLR and the key tape to be handled and viewed. From a high level sortie, there will be two photo records, one IR, one SLR and the key tape to be handled. The information density from the high level sortie will be greater, due to the coverage and resolution in the photo system particularly.

The control of the data for viewing will be from two sources. First, the geographic priority locations set up as assigned targets and as determined from priority analysis as "hot areas". The viewer then should have a capability of reading the data blocks and slewing records to a desired location (as determined from geographic readout or correlated time readout). Second, the priority of the keys versus unkeyed areas, thus passing by areas of record which have not shown alarm areas to concentrate on high probability areas for analysis.

These two methods should reduce the time to a minimum for a first OB status report. It will be necessary to rework the records to cover the areas not keyed, to locate margined information, which may be vital, or to provide detail technical information as requested by the air intelligence officer.

4.7.2.3 Detail Analysis

The instrument which displays the data to the analyst assumes a vital role in data management. For multisensor viewing it must have flexibility, while not overloading the analyst with peripheral information not vital to the task. It is suggested that the viewer be manned by two analysts, for this is the most useful compliment. There are some missions best analyzed by one man, some best handled by two, thus we must configure for two, to maintain usefulness. The best use of these highly trained analysts, is in viewing and working with the records. Therefore, again it is suggested that all requests for information, reports and com-

SPECIAL HANDLING

SPECIAL HANDLING

munication with the rest of the system be through a communicator, associated with the analysts to avoid attention shifting.

The viewer itself should be capable of simultaneously carrying the records from a sortie, which may run to eight film records and the key tape. For best human utilization only one prime viewing screen should be provided each analyst. The parallel record channels should be optically switchable, so that the two records displayed can be any pair from the eight in the machine. The standard features of frame translation and rotation should be included, and a magnification range from 4 to 20 times will be useful.

The analyst now has the basic tool for viewing. It displays the two records of choice, it has a data block readout, data block alphanumeric display, key control, key tape readout (alphanumeric), priority list display, and the necessary viewing tools such as high magnification stereo eyepieces and mensuration facilities, to enable the analyst to work the prime records.

The viewer must also display reference material, either text or imagery. The reference store configuration now becomes important. It is suggested that each analyst have a reference view screen, now making a total of four screens on the viewer. This should be sufficient, with the switching capability already mentioned.

The reference material will have been assembled from storage, based on the targets assigned, and the flight path. The priority analyst will have added to the reference those records called for based on his analysis including "targets of opportunity". It is suggested that the reference material be in a 6 by 9 inch card store format, thus utilizing the stored cover to its utmost. The use of the imagery in its original format (thus the 6 by 9 inch standard size to accommodate 5-inch film in aperture cards) reduces the storage system record manipulations and retains the maximum resolution in the material. All of the original formats fit this record size in one combination or another, and only removal from the film roll and insertion in the card aperture is required to update the image base file.

The predesignated 6 by 9 inch aperture card is designed to accommodate a 5 by 8 inch image. This format has been selected to enable storage of selected sensor records at full size. The images used in these aperture cards can be die-

SPECIAL HANDLING

4-197

SPECIAL HANDLING

cut from the original material or can be reproduced selectively in a variety of special devices. Because of the variety of applications for these records consideration should be given to storing them both as positive and negatives. Most desirable, providing the material has no further use, die-cutting the original positive to form the primary graphic record should be considered. Alternatively, use of diazo or kalvar material should be considered to form the primary record if the original negative must be retained in its original form. These materials are suggested because of their ease and speed of handling as well as avoiding the use of wet chemical processes made necessary by silver halide material. Reproduction of graphics for use in mission folders, and analytical viewers would be greatly simplified by the use of dry or near dry rapid processing duplicating material. Rapid scanning viewer printers would permit reproduction of reference graphics within the retrieval area eliminating the need for support from a photo laboratory for this area of effort.

Photographs are regularly taken of the most current OB status board. The photographs are processed and stored in the graphic file of the data base. These records are retrieved and reproduced to become part of the mission folder and are used as input material to the airborne keying display and the priority analysts display.

To handle the reference material in the viewer a concept which uses a card deck composed of all the reference material either text or imagery is suggested. The viewer will accept the card deck, sort and display a card utilizing a magnetic edge strip index, imposed on each card. Thus, random access to the reference material allows the analyst to rearrange his priority list at any time, and also add information on request during analysis which he may require.

The magnetic index can also be used to recall from the storage file if that system is automated. But both systems are alphanumeric-indexed so that degradation of the recall and reference viewing can be manual if required.

Further, although the key tape is the basic record of annotations used in analysis, each prime record has a digital record of the keys in its margin. Should the system be required to operate with such a simple reliable viewer as an emergency light table, then the keys are still available for use.

SPECIAL HANDLING

As useful to the detail analyst as to the priority analyst will be a supplementary display system. This will be a cumulative key and current OB status display, maintained from the computer disc storage, and updated to dynamically locate the aircraft position represented by the record being viewed.

The photograph of the OB plot, which is used as base material in the aircraft observer display, and the priority analysts display is produced from time to time as a basic reference image on 5-inch square high resolution film.

If system design permits, there is value in using 3 by 3 foot monitor display as noted above, for the analysts, and a larger 6 by 6 or 8 by 8 foot display for the command/decision display, operating simultaneously, deleting the aircraft indicator for the command display.

The reporting function will be handled as with the priority analyst. Human factors study clearly indicates a difficulty and loss of continuity from an attention change. The analyst in reporting or communication should be allowed to maintain his full attention on the records he is viewing, rather than reverting to the communicator role. Therefore by utilizing a third man on the analysis team, the attention shift is avoided.

The tasks of translating from the oral report to digital format and requests for information from the interpretation complex are easily handled by the communicator. In function, the update reports are maintained in a data card system as well as in the disc memory.

The detail analysts file reports in the following major categories:

1. OB Status Update, with a direct address to the disc storage system backed up by the simultaneous card file, read out either automatically or manually posted.
2. Graphic File Update, with selected target and areal coverage directed into the image store.
3. Digital File Update, with OB status changes and generation, simultaneous input to the disc storage and card file maintains the digital file, which can be searched regularly for OB update in command and control display systems.

SPECIAL HANDLING

4-199

SPECIAL HANDLING

4. Special Reports, as called for by the air intelligence officer, detail intelligence and technical data from the records in a repeat or original viewing.

5. Briefing Material, selected by the analysts for use in target briefing for strike and reconnaissance crews, areal and target imagery and data earmarked for briefing folders and reproduced by the photo laboratory on request of the air intelligence officer.

6. Mission Folder Material, selected by the air intelligence officer, for mission/sortie folders from the material provided by the analysts.

In detail, the analysts annotate the viewed material or notify the communicator of selection, so that the storage system receives marked positives for direct index annotation and file. From that point the air intelligence officer can call up on a separate viewer/printer, the image or text required for further use, whether in mission material, press releases, or "show me" hard copy for command and control.

In summary, the mission/detail analysis will deal with the prime record materials. The analysis priority will be determined from the assigned target list, modified by the priority analyst report for additions and reorder. The analysis will be performed on a two station viewer, with a prime screen and a reference screen for each analyst. The system will use the key and control tape to note key locations and/or control the record selection. The records will be contained in parallel channels, switchable at the operators option. The system will magnify, provide stereo viewing (adjacent frames) rotate and translate the imagery as required. The reference material will be supplied as full format aperture cards, magnetically keyed for index, geographical location and target type. The viewer can randomly select the material by a card search and display it for reference.

All reporting and other communications will be through a third operator/communicator, who will use a standard keyboard communications system to report OB status, and request new material. The OB cumulative plot with key indicators, flight path, and aircraft position will supplement the viewer, providing reference for the analysts. A repeater of the OB status plot will be used for command/control display. All reports will be made through the communicator, generating a disc record and a back-up punch card. The original viewer material

SPECIAL HANDLING

(spooled positives) forms the basis for imagery update, through analyst annotation for file. Original negative material is retained for disposition.

Mission/briefing material is generated from annotated original imagery in a separate viewer/printer associated with the storage facility.

4.7.3 Data Storage, Processing and Retrieval Center

The data base for the air intelligence operations consists of a large volume of data, occasionally in heavily clustered natural units, such as a multi-megabit photograph. The keying concepts developed previously make it expedient to store this material essentially in its natural form, and to process and retrieve it by manipulation and rearrangement of the associated low volume key data. This primitive distinction is of vital importance in outlining an optimum system, as it permits a clear division between the main memory requirement of the data store and the sorting and recombination requirements of the key data processor and its associated low volume memory store. The system which follows this distinction is a compact store for say 10^5 records, (each occupying less than 0.0025 cubic feet, or something like a 6 foot cube for 100,000 records) utilizing a small general purpose digital computer with I/O units matched to the data sort requirements, and alternate electromechanical and manual access systems to obtain the listed material from the data store.

The main data store, as it is formed, is composed of data base collateral information and update material, all processed and stored against a target type and geographical index. In configuring the storage system for manual back-up, the index system will generally be geography based, with target type as an add-on annotation. The computer index dictionary will perform the cross file conversion from target type to geographic location, so that a single storage base system can be used.

More specifically, the bulk data store, or record store, should have a random drum store as those used for large volume correspondence filing. Such a store can be organized to provide a slightly stylized representation of the terrain covered by the data base; this is a rule of "right hand drum is East, clockwise rotation of a drum moves the records North" would permit the rapid orientation for anyone required to pull material from store without the benefit of the

SPECIAL HANDLING

4-201

SPECIAL HANDLING

data processing facility. Similarly, edge coding of the aperture cards which carry the data base records (photographs, etc.) with colors to represent dominant targets found on the record would expedite the manual operation of the store. This initial emphasis on manual operation is deliberate; it is necessary if the system is to achieve a high reliability and graceful degradation under operational conditions which might include the lack of computer power or the unavailability of the especially skilled data processing personnel.

The actual controls of the store should consist of unitized sensor records (e.g., films cut into frames) or other representations scaled as nearly as possible to the size and format of the current sensors and uniformly mounted on aperture cards. This is both to minimize the number and complexity of process steps between first acquisition of operational records and their availability as additions to the data store, and to simplify the equipment (which may be naked eyes in extreme cases) required to compose current and fact records, and to ease the complexity of the task of making meaningful comparisons.

The capacity of the record store should be sufficient to accommodate the largest expected required data base, plus all records which might be acquired throughout an operational tour, say 72 hours. While it is recognized that under good conditions the records should be systematically culled, and records whose contexts are wholly updated by more recent coverage should be deleted, it is unfortunately true that most records are incomplete, and do not constitute an exact match in percentage cloud free area, shadow conditions, best achieved resolution, or distance of principal target from frame center. Failure on any of these counts can and should justify retention of both old and current imagery. Of course, whenever this is done, the old record should be annotated with a record of the availability of more recent cover (which may be in an adjacent drum because of center separation).

In summary, this bulk data store should contain a complete set of regional records, map card and all images, in geographic order, with the cards color coded for quick visual location of key target and sensor type records. This store would normally be manned by a specially indoctrinated file clerk, who could assist and guide professional manual users as necessary.

SPECIAL HANDLING

Fully automated operation of this store is not anticipated. However, its manual operation could be considerably expedited by using the output from the key data processor, which may be cards or paper tape, to drive the store. When so driven, the store would sequentially present each called-out record to the operator for quality check and extraction at a standard working level. Extraction could be accompanied by the insertion of a use reference card prepared by the key data processor, and mating the pulled record with a reference card which recorded the reason for presenting this particular record. These operations, of course, assume such an arrangement as magnetic edge strip control of the record aperture cards and use reference cards. The magnetic strip system will be mandatory if the viewer random access card deck concept is used.

The true computer associated with this store is the key/data processor. This machine would accept as input from an analyst (typically at a viewing station) a series of descriptors of required reference material making use of the geographic or target index system, and instructions to sort its records for the best matched records in main record store. The volume of its output from such a request would be a function of the degree of post sort judgment permitted in the (aided) manual extraction of main store material, which would in time depend on the type of data requirements which the analyst is faced with making the request. Thus, a man analyzing a particular building complex may want reference material relating to the particular buildings at a known location, which is relatively unambiguous; or he may want to see other examples of weapons storage facilities of the type which he suspects he is examining, backed by some central records of innocuous buildings of the same apparent class. Unless judgment and evaluation is exercised in the latter cases, he may be flooded with an unnecessary volume of reference material. To avoid such distractions of the working analyst, subordinate judgment should be exercised by the main store file clerk, aided by meaningful printouts of the descriptors which led to the callout of each record. Such considerations as these lead to the need for a high speed printout device for the key data processor. The characteristics of several disc storage/retrieval systems are found in Table 4-22.

The key data processor should be of the same general type as used in commercial inventory file and transaction record systems, typically, a small central processor and a multidisc system to permit prompt and efficient sorts and up-

SPECIAL HANDLING

4-203

SPECIAL HANDLING

SPECIAL HANDLING

SPECIAL HANDLING

Table 4-22 - Typical Operational Characteristics of Disc Storage Systems

COMPANY NAME	MODEL	STORAGE MEDIUM	STORAGE CAPACITY PER PHYSICAL UNIT					HEAD POSITIONING TIME (MSEC.)			AVG. ROTATIONAL DELAY (MSEC.)	PEAK DATA TRANSFER RATE (CHAR./SEC.)	TRANSFER BAND SIZE (CHARACTERS)	READ/WRITE CHECKING	REPRESENTATIVE COST (DOLLARS/CHAR)	FEATURES & COMMENTS	
			DATA DISC OR DRUMS PER PHYSICAL UNIT	DATA TRACKS PER DISC SURFACE OR DRUM	MAXIMUM CHARACTERS PER TRACK	MAXIMUM CHARACTERS ACCESSIBLE WITHOUT HEAD POSITIONING	MAXIMUM CHARACTER CAPACITY PER PHYSICAL UNIT	MAX. # PHYSICAL UNITS ON-LINE	MAX.	AVG. RANDOM							MIN.
HANWELL 460	BRANT 4000	DISCS	3, 6, 12, 18 or 24	768	4,096	786,432	10,663,816	1	60	95	130	33.5	27,500 or 70,000	512	PARITY	0.0026 PC	ALL READ/WRITE HEADS (6 PER DISC SURFACE) MOVE IN UNISON
ACA 350	BRANT 4000	DISCS	6, 12, 18 or 24	768	1,600	691,200	8,413,600	2	70	105	150	25	32,000	1 to 1,600	PARITY	0.0040 PC	ALL READ/WRITE HEADS (6 PER DISC SURFACE) MOVE IN UNISON
BURROUGHS	B472	DISCS	4, 8, 12 or 16 or 20	50	24,000	TOTAL CAPACITY	48,000,000	20	-	-	-	20	100,000	96 to 30,240 by 96,240 to 480	CHECK CHAR. WRITE CHECK	0.0053 PC	FIXED HEADS, 1 PER TRACK
DATA RECORDS	5024	DISCS	16	256	5,120	524,288	33,594,432	28	35	120	200	2.6	58,800 or 98,000	8 to 32, 768	CHECK CHAR. WRITE CHECK	0.0062 PC	INDIVIDUALLY POSITIONABLE ACCESS ARM FOR EACH DISC
G.E. DISC STORAGE UNIT	MA14	DISCS	4, 8, 12 or 16	256	3,072	294,912	18,874,368	52	70	199	305	2.6	35,500 or 71,000	192 to 3,072 by 192	WORD & RECORD PARITY	0.0065 PC	INDIVIDUALLY POSITIONABLE ACCESS ARM FOR EACH DISC
I B M DISC STORAGE	1301	DISCS	20 or 40	250	2,780	222,400	55,600,000	5	50	160	180	17	90,000	170 11,200	CHECK CHAR. WRITE CHECK	0.0041 PC	INACCESSIBLE RECORD LENGTHS, DEFINED BY FORMAT DISC
I B M DISC STORAGE	1302	DISCS	20 or 40	500	5,850	930,000	234,000,000	5	50	165	180	17	184,000	170 234,000	CHECK CHAR. WRITE CHECK	0.0018 PC	TWO ACCESS "COMDS" SERVE 250 TRACK POSITIONS EACH, VARIABLE RECORD LENGTH
I B M DISC STORAGE	1405	DISCS	25 or 50	200	1,000	2,000 or 4,000	20,000,000	1	90	600	800	25	22,500	200 or 1,000	PARITY, WRITE CHECK	0.0030 PC	SINGLE ACCESS ARM SERVES ALL DISCS (SERVING ARM IS OPTIMIZED)
IBM DISC STORAGE DRIVE	1311	DISCS	5	100	2,000 or 2,980	20,000 or 29,800	20,000,000 or 29,800,000	5	75 or 54	250 or 154	392 or 248	20	77,000	100 to 20,000 by 100	PARITY, WRITE CHECK	0.0234 or 0.0163 PC	CHANGABLE DISC PACK "CANT" NAMES OF 5 DATA DISCS EACH
NC R ORAM UNIT	333-1	MAGNETIC CARDS	OLE 236 CARTRIDGE	7 PER CARD	3,100	21,700 (1 CARD)	5,335,200	16	235	235	235	23	100,000	2 to 3,100	TWO-WAY PARITY READ AFTER WRITE	0.0068 PC	CHANGABLE ORAM CARTRIDGES OF 256 CARDS EACH, 8 BIT CHANNELS PER TRACK
NC R ORAM UNIT	333-2	MAGNETIC CARDS	OLE 236 CARTRIDGE	28 PER CARD	886	24,808 (1 CARD)	6,350,948	16	235	235	235	23	28,500	2 to 886	TWO-WAY PARITY READ AFTER WRITE	0.0048 PC	CHANGABLE ORAM CARTRIDGES OF 256 CARDS EACH, 1 BIT CHANNEL PER TRACK
ACA DATA RECORD FILE	361	DISCS	128	2	9,000	9,000	4,608,000	6	300	4,300	5,500	2,100	2,500	1 to 9,000	PARITY	0.0046 PC	INDIVIDUALLY CHANGABLE DISCS IN "CAROUSEL" ARRANGEMENT
LIBRASCORE DIV.	11300	DISCS	2706	256	49,900 or 875	153,000,000 or 316,000,000 or 53,000,000	53,000,000	-	70	35	-	-	356,000	-	-	-	FIXED POSITION FLYING HEAD 1 PER TRACK

SPECIAL HANDLING

SPECIAL HANDLING

dating operations. Multiple access and real time time-sharing should be assessed; there is no cause for concern if there is discernible flicker in response to each user, because unit response and action times for working professional analysts are represented by minutes rather than milliseconds. While input must be accepted from each of several user stations, there is probably need for only one high speed output device. However, each user should have low speed return facilities, typically, the same electric typewriter as he uses for input. His low speed output channel should simply inform him of the gross results of his requests - for example - "none available" or "96 printed out to main store" or "3 approximations found - do you want them?" The last entry is inserted to raise the issue of the general lack of precision in callouts from such data stores. We should not fail to produce a record when the nominal center called for is slightly away from the nearest on file, nor should we present one only record when several have the required photographic coordinates each in a different corner. Programming around these problems of operational common sense is painfully slow, and leads to results which convince everyone but the programmer (who already knows) that the machine is a high speed idiot; we recommend the retention of a junior man in the record pulling operation, because of the judgment available from him, and the confidence that he represents a truly adaptive link in the data processing sequence.

The insertion of new data evidently takes place at two levels. The master file of the key data processor system can be updated directly by the readout of the prime record data block, plus any annotations by the examinations analyst. This operation does not require the physical transfer of any material. The bulk data store is updated by a combination of copy from the prime record, as indexed and annotated by the key data processor. This indexing operation takes input from the data block, analyst, the master file, and the record store index. The key data processor uses a separate program to combine these inputs and to produce aperture card sticker outputs proper for each frame (or other unit record) and an indication of other records which should be examined for possible calling after insertion of the current frame. These aperture cards are made up in the photo reproduction section, and inserted into the bulk data store as soon as convenient. After insertion, a record of insertion and availability is entered as to the index memory and working file via a set of transaction cards which was

SPECIAL HANDLING

4-207

SPECIAL HANDLING

prepared concurrently with the aperture card stickers. The phasing of the operations calls for close control to prevent undue delays in access on one hand, and undue interruption to operational use of the main store on the other. A well-defined system of priorities and a careful design of the input system is called for to minimize aperture card insertion time.

The transmissions of reference material from the bulk data store should involve minimum time and minimum personnel movement. A high-speed spring or pneumatic tube system is favored for this task. This system would also enable the analyst to bypass the computer and feed graphic requests to the file clerk in cases where formal descriptions would evidently produce a large volume ambiguous reply. A back-up system of bulkhead apertures and hand passage should be set up to ensure continued operation at degraded speeds in the event of operational damage to the hard copy tube system.

With the analysis viewer set up to accept the reference material as a random access card deck, new information can be added during the analysis without regard to sequence. As previously noted, the magnetic edge coding, imposed when the aperture card is annotated with the index sticker, now provides the means of random access by the analyst. The use of a communicator to perform the computer/data store interface function is reiterated here, to relieve the analyst of detail functions not pertinent to the task for which he is trained.

A detailed discussion of data handling for the side looking radar, ELINT, and infrared outputs are discussed in sections 4.7.5, 4.7.6 and 4.7.7, respectively.

4.7.4 Support Facilities

As an adjunct to the storage and retrieval problem there is a need for support facilities to perform routine photographic work which will be associated with the data management process.

Photographic Laboratory — There are a number of applications for a photographic laboratory aboard the carrier primarily to finish material processed aboard the reconnaissance aircraft, to process HRR correlated images, reconstituted IR and video images, material generated for graphic storage, and printed

SPECIAL HANDLING

products from graphic storage for use in mission folders, detailed analysis and keying or priority displays. Printing equipment for these applications fall into the continuous printer, step-and-repeat printer categories. Reproduction of records from the graphic files would be accomplished essentially by viewer - printers obviating the need for laboratory services for this application. The normal complement of support equipment to enable chemical mixing, titling, inspection, splicing, cleaning and quality control will be required.

Duplicators — Until recently, with limited exception, military duplicating equipment was generally configured around designs originated for commercial use. Recent advances in mechanics and optics are leading to duplicator designs particularly applicable to military reproduction problems. Previous devices were limited to one type of operation while this new generation incorporates many capabilities. These devices are now configured to perform any combination of tasks from the following:

1. Dodging
2. Non-dodging
3. Continuous enlarging
4. Continuous contact
5. Step-and-repeat enlarging
6. Step-and-repeat contact
7. Automatic exposure and contrast control

These duplicators, which operate at high production rates, enable a wide variety of printing tasks to be accomplished with a lesser equipment complement.

Processors — The predominant military processor has been the deep tank immersion or spray processor. A wide variety of devices falling into this category are in current military inventory. There have been recent developments of a new straight-path rapid processor which is particularly applicable to tactical operations. These processors operate to a greater or lesser extent on the liquid/air bearing principle, minimizing the amount of mechanical contact imposed on the film. These devices are self threading compact and simple to operate and maintain. More recent developments will result in a modular processor with the capability for any type of material, black and white or color, simply by assembling the appropriate number of modules and connecting chemical delivery to the proper number of applicators in the proper sequence. Production speed can also be increased by adding modules. Current processors require fresh water for washing

SPECIAL HANDLING

SPECIAL HANDLING

at up to 45 gallons per minute. Recent developments in resin de-ionizers permit recirculation wash systems requiring very little new fresh water.

Duplication of the high quality high altitude photography will be required to a limited degree. In this event the quality of the duplicators and the processor must be such that a minimum amount of detail is lost in the duplication process. To support these devices the facility must have a controlled environment with regard to temperature, humidity, dust and contaminants. Strict quality control procedures will be required to provide a full range of quantitative spectrometric data as a measure of product quality.

Automaticity in operation is desirable when production requirements are high, and space and personnel are limited. Recently developed techniques can permit a fully automatic printing system which operates from data marked on the edge of each negative which controls all aspects of printer magnification positioning, exposure and volume. Such a system includes an editing console and automatic printer/processor. Such a printer/processor combination would be valuable to support high volume, short term duplication requirements for the graphic data base as well as serving other requestors for duplicating services.

4.7.5 Side Looking Radar Data Handling

It is anticipated that the processing of high resolution radar pictures aboard the carrier will use the basic procedures, equipment, and storage method that is used for the other image systems. For example, the film viewer has the capability to look at enlarged sections of film, measure the distance between two points on the film, perform restitution and coordinate conversion and transformation in order to obtain ground coordinates, and compare two film views of the same area. The storage media which employs film "chips" mounted in cards can be used for the storage, classification, and annotation of radar data from the high resolution side-looking radar.

It is proposed that the film taken by the high resolution radar be annotated along its edge as taken, in the same manner that the film from aerial cameras is now annotated. That is, information concerning latitude and longitude of the aircraft, radar pointing angles, altitude of aircraft and time would be put on a data block on the side of the film. Also, the priority key will be im-

SPECIAL HANDLING

printed along the edge at appropriate locations.

4.7.5.1 Priority Target Indicators

A priority target could be caused by:

1. moving target indication,
2. cross section threshold indication,
3. IR hot spot indication,
4. ELINT indication of preselected type,
5. indication given by the aircraft observer for any reason.

It is suggested that these priority keys be sent back to the carrier via data link and also be placed on the radar film when appropriate. These keys are used to indicate that priority viewing should be given to the portions of the film where the priority key is present. These keys are used aboard the carrier for several different purposes:

1. performing some data interpretation before the aircraft returns to the carrier,
2. selecting pictures and data from the data store to compare with the reconnaissance data just taken,
3. scheduling film reading and interpretation.
4. planning the mission of reconnaissance sorties which will take off in the near future.

This real time interpretation aboard the carrier could, for example, indicate unusual traffic on a given road as the moving target indicators are plotted on a map; or the presence of a new type of emitter and its location. It should be noted that even if this priority keying information is not sent back to the carrier via data link, the priority keys are still present on the film and can be of great value.

4.7.5.2 Automated Changed Detection

The use of automated change detection techniques is possible when two radar pictures of the same area are compared. These pictures must be taken from the same flight path, altitude, and aspect angle but are independent of time of day.

SPECIAL HANDLING

SPECIAL HANDLING

This occurs because the radar carries its own illumination and thus shadowing effects just depend on position of the radar.

Automated change detection can take several forms. The first is a blinking system as used in astronomy. In this system two views of the same area are alternately shown to the observer and areas which disagree tend to blink on and off, much like a blinking light. This blinking effect then indicates the portion of the reconnaissance area at which a change has occurred.

The grey spot method can be used also, in which a positive and negative image are overlaid.

An optical target-matching and target change detection technique which greatly simplifies area contrast correlation has been developed at Condustron on a company sponsored program. This technique has been applied in several proposals to problems of high resolution map matching and moving target indication. The application to target tracking is also simple and direct and gives the desired effect of area tracking without complex computation.

Another approach to the change detection process is to bring the two picture areas under study into a close match by scanning them with a flying spot scanner and performing a multiplication correlation on the outputs of the photo-tubes. Once the areas are matched, they are scanned and photo-tube outputs are sent to a subtractor, whereby any difference in the areas in question will appear as electrical outputs. The difference signals are then filtered and processed. The processed output places an indication of change on a radar photograph identical to either photograph (as selected by the operator).

4.7.5.3 Discussion of Change Detection

The detection of changes requires that the area under consideration was covered more than once so that the sensor records obtained on different missions can be compared. The detection of changes can be accomplished in several ways.

1. In the case of point surveillance when one looks for changes at narrowly defined locations, the detection, description, and interpretation of changes is easily accomplished and reported.

SPECIAL HANDLING

2. In the case of area-surveillance when one must scan the entire record to find changes, the detection becomes a formidable task. Because the changes tend to get lost in the mass of image information which must be reviewed in area surveillance, the automatic extraction of differential changes is extremely helpful.

The outputs from change detection can be manual isotime plots of change locations and identifications, for example on sliding Plexiglass panels, or they can consist of automatically derived change records which then have to be annotated. The automatically derived change records can be on transparencies and appropriately scaled so that the transparencies can be superimposed onto area maps or projections. While it will be possible to selectively plot positive changes (additions) or negative changes (deletions) when manual change compilation is practiced, the automatically derived records will show both positive and negative changes, which, however, can be printed in different colors.

The use of change of position of tactical detail as a discriminating parameter provides a most valuable capability for distinction between dead and live detail. Such things as destroyed tanks and trucks, disabled railroad equipment, etc., eliminate themselves from judgment by disappearing from the presented picture of "changes". This fact does not reduce the systems capability for producing an integrated picture of the operational situation through sensing the positive and negative changes as they occur. Positive and negative changes are separately presented as influx into or outflux from an existing permanent terrain pattern.

It is anticipated that many times when tactical intelligence will be urgently needed only the side-looking radar records and the attack radar scope photography will be available for deriving the called for information. Although the detection of small tactical targets such as vehicles, missile launchers, tanks, etc., is assured by the "resolution" of the proposed side looking radar set, the radar returns from the vehicles will appear as "blobs" on the record just like those caused by the returns from isolated houses, rocks, or similar permanent corner reflectors in the terrain. The recognition of certain "blobs" as important mobile tactical targets rather than as fixed terrain corner reflectors is difficult if repetitive coverage of the area by SLR is not available. However, the

SPECIAL HANDLING

4-213

SPECIAL HANDLING

deployment of large numbers of vehicles will generally follow systematic patterns related to the road and rail net, waterways, harbors, airports, etc. Furthermore, large numbers of military vehicles will always form patterns compatible with established military behavior and doctrine. Thus, interpretation of tactical targets must rely heavily on the recognition and exploitation of patterns.

The changes recorded during the previous data reduction step represent all machine-recognizable differences in the compared SLR imagery. Therefore, the change records will contain not only true changes, but also psuedo changes that are caused by differences in aspect angle, terrain clutter, scintillation, malfunctions, etc. In general, the distribution of the psuedo changes is non-systematic while the true changes, particularly those caused by returns from large numbers of vehicles, will follow systematic patterns related to the road and rail net, terrain, and established military behavior and doctrine. Hence, it will be possible to eliminate quickly from further considerations the majority of psuedo changes. The changes found are of two types: positive (new returns are found) and negative (returns formerly observed but now absent).

A piece of equipment which can be used to examine areas of change is essentially a projecting measuring device which permits examination of the change record and the radar terrain imagery from which the change record was derived. Provision is made for a number of magnifications and for optically superimposing the SLR records in any chosen combination. The radar terrain imagery then can be used for the analysis of the changes of comparison with norms for the area under consideration.

During interpretation the individual SLR change records are analyzed in order to extract information found on these records. These data can be in the form of target numbers, and distribution and changes in patterns. From these data the interpreter applies meaning to produce intelligence information. Once positioned, correlation of SLR changes with terrain transportation nets and cultural detail can be made. Verification of changes is also accomplished at this step, permitting only the significant changes to go to multisensor interpretation.

4.7.5.4 Multisensor Interpretation

Changes can now be evaluated jointly in terms of probable enemy intention

SPECIAL HANDLING

and/or the establishment of an order of battle. This function is called Multi-sensor Interpretation (MSI). Norms are kept current for area elements by considering over a period of time, both quantitatively and qualitatively, such factors as landforms, terrain trafficability, population density, industrialized areas, traffic schedules and patterns, time of day, and other daily variations of field forces. The operational patterns for differing numbers of vehicles and different types of emitters are established and maintained up-to-date by technical intelligence, the study of military doctrine, and the continuous analysis of enemy tactics, training procedures and posture. All of these inputs to MSI are part of a systems file that contains map transparencies, texts, graphics, and imagery.

The radar records are also processed for defined doppler frequencies as caused by vehicle motion, thus automatically eliminating all stationary information and producing a separate MTI record showing detail in motion only. Using color differentiation, this record can be divided into a desirable number of speed intervals. The scale of the motion record can be compatible with that of the record of changes to enable overlay viewing.

The store of imagery, maps, text and graphics is contained in microfilm and transparencies in order to minimize space and weight considerations. Map transparencies are used in the positioning function of the SLR data. Technical and general information from the file is furnished during interpretation and MSI. Information and graphics (previous change records) are taken from the file and used during comparison in the data reduction sequence.

4.7.5.5 Carrier Based Equipment

Much of the current carrier based equipment is consistent for use with the synthetic array radar system discussed in this report. However, some additional pieces of equipment would be required which are as follows:

1. Coherent optical processor for the reduction of the raw data films received from the aircraft.
2. A special purpose piece of equipment to perform change detection on processed signal films.

SPECIAL HANDLING

4-215

SPECIAL HANDLING

3. A method of storing and obtaining the precise navigation information required for repetitive cover runs - needed if automated change detection is used.

4. A data link receiver and data handling equipment to expedite the handling of the keying information and relaying it to the priority analyst.

5. The addition of a priority analyst display station in addition to the present reconnaissance stations.

4.7.6 ELINT Data Handling

Basically, the data handling system for ELINT involves processing of a magnetic tape removed from the aircraft on a large general-purpose computer. The outputs from the system are printed lists of emitters (with characteristics and locations) from a teletypewriter, and an annotated plot of the same emitters on a large automatic map plotter. There are several different computer programs available to permit printout and plots of the output data from a number of statistical viewpoints, but correlation with other sensor records is done by the analysts and operators.

In the optimized system, these same data flow paths and techniques exist for the low priority ELINT data, but additional capabilities and facilities have been added to separate the high-priority data rapidly from the total ELINT collection, and to correlate the ELINT data reduction and outputs with similar high-priority data from the other sensors. These additional capabilities arise primarily from the use of the ELINT real time computer in the aircraft, and the availability of the sensor keying and control tape on the carrier. The airborne computer accomplishes much of the ELINT processing presently being done on the ship, identifying by function and locating preselected types of emitters. The keying tape contains this predigested ELINT data from the computer and, in addition, contains similar predigested high-priority data from other sensors and the observer. The keying tape, therefore, provides the means for correlating the most significant ELINT information with the most significant (and unique) moving-target, hot-spot target, and observer data, collected by the HRSIR, IR and observer, respectively. Furthermore, since the digital information denoting each

SPECIAL HANDLING

keyed target on the keying tape also contains the location of the target in time and in cross range, the ELINT and other sensor keys can be cross checked against the photographic and IR map imagery (which do not provide keys for the keying tape).

The improved multisensor data correlation process made possible by these innovations can be speeded up and improved to even a greater extent, when the reconnaissance aircraft is able to use its wide-band data link to send sensor imagery to the ship in real time. Here again, however, it is the use of the sensor keying data transmitted with the imagery which enables the greatest improvements to be realized. It is of little use to obtain a great deal of sensor imagery in real time if there is no indication as to what might be valuable and what might not, or what the priority of viewing should be. By scheduling the viewing and cross checking of target locations through the use of the keying tape, however, reduction of even the real time data processing and analysis cycle will be improved considerably. For example, as soon as the data starts coming over the link a permanent plot of the location of all keys will automatically begin, the ELINT keys being identified as to type of emitter. At the same time, the attention of the reconnaissance analyst and his staff will be directed toward the examination of those IR and HRSIR map images being produced at the locations dictated by the keying tape. Even though final confirmation of any results obtained from this early screening would probably have to be deferred until it could be checked against the photographic imagery when the aircraft returned, the amount of prefiltering already accomplished would undoubtedly reduce the subsequent cycle time appreciably. When the data link is being used, a duplicate of the aircraft observer's real time situation display is also available in the Priority Analysis Center of the carrier. This display is derived from the same signals used in the aircraft to produce the observer's display namely the keying tape and IR map, and which are transmitted to the ship.

Finally, one of the most important advantages to be gained in the shipboard data processing cycle through the use of the keying-control data is that the signal contents of the tape can be transmitted over long distances beyond the line-of-sight by using a high frequency (HF) air-to-ground communications link. This is technically feasible because the information content of the keying signals (bits per second) is low enough to allow very reliable transmission within

SPECIAL HANDLING

4-217

SPECIAL HANDLING

standard HF channel allocations. Now the intelligence center on the carrier has access to the observer's real time display and the keying data, even when the reconnaissance aircraft is beyond the line-of-sight. The amount of data received is smaller than when the wide-band link is being used (the IR map image cannot be handled by the narrow-band link), but the aircraft flight path, complete ELINT data, and other sensor key data can automatically be plotted, and advance preparations begun. In fact, rather complete intelligence on high priority enemy activities will be available at a very early point in the overall reconnaissance cycle, and will include a considerable amount of sensor cross-correlation on significant targets.

4.7.6.1 Subsystem Description

The shipboard data reduction and processing system for the ELINT subsystem must meet the following requirements:

1. Rapid data processing and release of information to mission planners. Priority information should be available within seconds of receipt by radio link; all but low priority, data-base type of information should be available within one-half hour after the reconnaissance aircraft has landed.
2. Rapid correlation of ELINT keys with the high priority keys of the other sensors so that meaningful data will be screened and processed first.
3. Correlation of ELINT data with Radar Order of Battle and known radar parameter lists, to confirm the presence of specific emitters at precise locations.
4. Flexible filtering of output data to restrict teletypewriter printouts and plots to emitters with specified characteristics, or to emitters located within prescribed geographical areas.
5. Printout of selected data on plotting boards, teletypewriter, and magnetic tapes.
6. Correction of ELINT location data by information from the reconnaissance analyst. The latter obtains this information by location data from the photo, IR and HRSLR sensor records.

SPECIAL HANDLING

Since the airborne computer has done important presorting of the ELINT intelligence aboard the reconnaissance aircraft, the important ELINT flow path becomes the data-link path, which starts with the keying control tape and proceeds through the Data Correlation Center to the Priority Analysis Center. Here ELINT signals are displayed on the priority viewer, or plotted on the analog key data plotting board. This is the flow path for the ELINT data which have been predigested in the airborne computer and is available on the keying tape in the form of emitter locations and functional types.

If the data link is not used, the keying tape record removed from the aircraft becomes the starting point for the ELINT priority path, and flow-wise progresses through the computer to the teletype printer and the analog plotting board. The ELINT tape removed from the aircraft is not needed for the high-priority analysis and can be used to do the conventional ELINT reduction at a later time. Since the keying and control tape contains ELINT data which have already been reduced in the air, plus all of the other high-priority sensor keys, it is the starting point for all of the high priority data reduction on the carrier, whether the data links are used or not.

If the HF data link is being used (aircraft beyond line of sight to the carrier), a keying tape is made in the Priority Analysis Center from data being received. The same data are used to operate the priority viewer in the Priority Analysis Center, and can be fed to the ELINT computer in the Data Storage, Processing and Retrieval Center, while the tape is being made. The output from the computer will then operate the two plotting boards, one next to the reconnaissance analyst in the Data Analysis Display and Interpretation Center, and the other next to the priority analyst in the Priority Analysis Center. Thus, all high priority key data will be presented in real time on a viewer and plotters, and a keying tape will be available to control the processing and viewing of the imagery data when it becomes available.

When the wideband data link is being used, there is no change as far as the processing of ELINT data is concerned. ELINT data filtered by the airborne computer, and placed on the keying and control tape, still is displayed on the viewer and operates the two plotters. When the keying and control tape is reproduced on the ship, however, it can be used immediately to filter and display

SPECIAL HANDLING

4-219

SPECIAL HANDLING

the IR and HRSIR imagery received over the wideband link.

If no data link is used, the ELINT data on the keying and control tape, and the ELINT data on the ELINT tape, are removed from the aircraft. The keying tape, however, has the high-priority data and would be processed through the computer immediately in the Data Storage, Processing and Retrieval Center. The ELINT tape removed from the aircraft contains a record of every pulse word received from emitters during the mission, and can be processed in the same manner as present ELINT tapes are processed to derive complete ELINT intelligence on all emitters intercepted.

An additional flow path exists for ELINT data reduction when both the ELINT tape and keying tape are available after a flight. If the keying tape is used to control the reduction of the ELINT tape in the computer, there is a possibility of identifying emitters keyed by the IR or HRSIR (moving vehicle or rotating antenna) which may not have been identified and processed by the airborne ELINT computer.

The remaining flow paths for ELINT data retrieval and storage are discussed later in this report with the other sensor library materials.

4.7.6.2 Detailed Data Flow

The computer on the reconnaissance aircraft has the capacity to completely process a maximum of approximately 20 priority emitter types, and to write their identities and locations on the keying tape. As soon as narrowband communications with the carrier becomes feasible, the keying tape is transmitted.

The shipboard receiver output is fed to the processing location in the Data Correlation Center so that a keying tape can be prepared for subsequent correlation of the sensor imagery. In real time, however, the output from the receiver will also operate the priority viewer (in the Priority Analysis Center) and, through the computer and D/A converter the two plotting boards.

When the keying tape is completed it can be run through the computer (if the computer is not "on line" for real time plotting) to correlate ELINT data with the other sensor keys, and the ELINT ROB library tape which is entered into the computer. When emitters whose identity and location correlate with the other

SPECIAL HANDLING

sensor keys or the ROB tape are found, they are printed out on the ELINT teletypewriter output. Since the keying tape constructed from data received over the narrowband link contains ELINT data, ELINT processing can be done as soon as the computer is free.

Although the use of the computer has been indicated to process the ELINT, MTI and hot-spot targets for real time plotting, it is probable that the plotting will be able to be done directly from the received digital signal. The outputs from the data link receivers will then go directly to the D/A converter, and the computer will not be used for "on line" work.

When the wideband link is used, IR and HRSLR imagery are also received on the carrier, and will be processed while the keying tape is being made. The keying tape then will be used by the computer to control the display of the IR and HRSLR imagery on the main image viewer at the reconnaissance analyst position to locate the significant targets keyed.

Processing of the complete ELINT record tape will be as described in Volume 2, Target Characteristics, with the additional assistance of the keying tape for multisensor correlation. All of the computer programs for special filtering of the output plots and printouts will be available and should be used as required. This filtering has the advantage of unburdening the processors and the operator of data which is not applicable to the specific mission in process. Samples of programs which might be used in special situations are as follows.

Location Selection — Data are processed only for emitters within a given region. The region can be specified in the following terms:

1. latitudes and longitudes of the boundaries
2. location of center and radius of circular area
3. locations of points defining a polygon
4. locations of points defining a flight path and the range covered on each side of the flight path.

If it is desired to restrict the data processing to the area covered by other sensors, the range from the flight path can be automatically computed from the altitude.

SPECIAL HANDLING

SPECIAL HANDLING

Characteristic Selection — Data is processed only for emitters designed for specified functions. For example, if printout is desired only on anti-aircraft fire-control radars, the data would be filtered for the parameters of Whiff, Firecan, and other AAA radars, and printed out.

Emitter data, filtered as required by the appropriate location and characteristic selection can be plotted on transparent map overlays. The plotting board includes digital-to-analog conversion of the location coordinates, and a head capable of printing the essential information about the emitter, such as the type and identifying number. In addition, the teletypewriter provides a printout of the filtered emitter activity for visual analysis and for record purposes.

4.7.7 Infrared Data Handling

Upon landing of the reconnaissance aircraft, the magnetic tape and the processed film containing the high resolution infrared imagery is taken to the Data Correlation Center. The film is loaded into the PI viewer, and the imagery is interpreted visually in conjunction with the information from the other sensors. The keying tape may be used to select specific imagery for priority analysis or to cue the PI to objects of interest on a given frame.

The magnetic tape containing the high resolution infrared quantitative data may be employed to produce secondary keying tapes by synthesizing fields of view and threshold levels other than those originally selected by the aircraft observer. These key tapes may then be used to provide additional cueing information to the photointerpreter. In addition, the tape may be processed to obtain quantitative information regarding the size and temperature difference of particular objects as requested by the photointerpreter. This information is extracted automatically by digitizing a region upon request from the PI and providing the information either as symbol display by CRT or as typewriter printout.

Priority analysis aboard the carrier may be performed during the data gathering mission by making use of the infrared imagery combined with the cueing information on the priority data link.

The display provided to the priority analyst is essentially identical to

SPECIAL HANDLING

SPECIAL HANDLING

that provided to the aircraft observer. It is a synthetic display which incorporates a photographic presentation of the expected flight path, plus the imagery transmitted from the IR and SLR sensors. The keying data is displayed in a symbolic form to aid the interpreter. He may elect to display only information from selective geographical locations or information for which several sensors indicate high priority.

The infrared data is stored in both film and magnetic tape format. Selected imagery or quantitative data may become part of the intelligence data base. The remainder of the data is discarded at the end of its tactical lifetime.

The data stored on magnetic tape remains in analog format but the digital data block associated with each scan permits ready access to the analog information through the use of digital tape search routines. Analog to digital conversion is performed by conventional methods and the resulting data, both amplitude and position, may be printed or displayed numerically.

The film records of the infrared imagery are essentially identical to the photographic records and are similarly stored and retrieved.

The output of the infrared reconnaissance equipment is in the form of visual display and OB status presentation during a tactical situation. In addition, it may be used to provide supporting interpretive information as required.

Data selected by the air intelligence officer may become part of the permanent data base in either digital or film format as requested by the PI.

SPECIAL HANDLING

4-223

SPECIAL HANDLING

SPECIAL HANDLING