

4

\*USAF Declass/Release Instructions On File\*

# ACCIDENT FOLDER

## ART 133

*excess copy  
was destroyed  
13 Nov 70  
KV*

DATE OF DOC	DATE REC'D	DATE OUT	SUSPENSE DATE	CROSS REFERENCE OR POINT OF FILING
	20 JULY 64			
TO FROM SUBJ. <del>XXXXXXXX</del> A-1H Aircraft Accident.				ROUTING
CY 1 GND 2 D/Tech 3 Col. Gandy " "				DATE SENT
COURIER NO.	ANSWERED	NO REPLY		4

**SECRET**

307/  
COPY 1 OF 4

TAB LETTER	USAF ACCIDENT/INCIDENT REPORT CHECKLIST AND INDEX	NOT APPLICABLE	APPLICABLE NOT ATTACHED	ATTACHED	NO FORMS ATTACHED
A	AF FORM 711			X	
B	AF FORM 711a	X			
C	AF FORM 711b			X	
D	AF FORM 711c			X	
E	AF FORM 711d	X			
F	AF FORM 711e	X			
G	AF FORM 711f	X			
H	AF FORM 711g			X	
I	UNSATISFACTORY REPORT	X			
J	TEARDOWN DEFICIENCY REPORT	X			
K	LIST OF TECHNICAL ORDERS NOT COMPLIED WITH <i>See Tab W Maintenance &amp; Records Gp</i>			X	
L	AFTO FORMS 781 SERIES <i>See Tab W Maintenance &amp; Records Gp</i>			X	
M	AF FORM 5			X	
N	STATEMENTS			X	
O	REBUTTALS	X			
P	ORDERS APPOINTING INVESTIGATING BOARD			X	
Q	BOARD PROCEEDINGS <i>See Tab A</i>			X	
R	DD FORM 175 OR DD FORM 1080			X	
S	DD FORM 365 (Weight and Balance Clearance Form F)	X			
T	STATEMENT OF DAMAGE TO PRIVATE PROPERTY			X	
U	CERTIFICATE OF DAMAGE (List of Parts Damaged), MANHOURS REQUIRED TO REPAIR, AND COST			X	
V	TRANSCRIPTS OF RECORDED COMMUNICATIONS			X	
W	ANY ADDITIONAL SUBSTANTIATING DATA REPORTS			X	
X	OTHER AF FORMS (Failure and Consumption Reports, Etc.)	X			
Y	DIAGRAMS (Fall Out—Impact Area, Etc.)			X	
Z	PHOTOGRAPHS			X	

Whenever "Applicable but not attached" column is marked for any of the above items, information must be entered under remarks to indicate what action has been taken or will be taken to obtain the required attachment. Lettered tabs shown above will be inserted for corresponding attached items, i.e., Tab N will always be used for Statements, Tab P for Orders Appointing Investigating Board, etc. Tabs will be omitted on those items not applicable.

REMARKS:

**SECRET**

25X1A

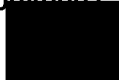

3071

copy 184



OXGART

SECRET

<b>USAF ACCIDENT/INCIDENT REPORT</b>							
(Fill in all spaces applicable. If additional space is needed, use additional sheet(s).)							
1. DATE OF OCCURRENCE (Year, month and day)  9 July 1964		2. VEHICLE(S)/MATERIEL INVOLVED (TMS & Serial Nr., if applicable)  A-12			3. FOR GROUND ACCIDENTS ONLY (Base Code and Report Serial Nr.)  N/A		
4. PLACE OF OCCURRENCE: STATE, COUNTY, DISTANCE AND DIRECTION FROM NEAREST TOWN. IF ON BASE, IDENTIFY. IF OFF BASE GIVE DISTANCE FROM NEAREST BASE. Det 1, 1129th USAF Spec Act Sqdn P.O. Box 882 Las Vegas, Nev				5. HOUR AND TIME ZONE LOCAL  0930		6. <input checked="" type="checkbox"/> DAY <input type="checkbox"/> NIGHT <input type="checkbox"/> DAWN <input type="checkbox"/> DUSK	
7. ORGANIZATION POSSESSING OWNING VEHICLE OR MATERIEL AT TIME OF MISHAP							
Major Command	Subcommand or AF	Air Division	Wing	Group	Squadron or Unit	Name and Base Code	
N/A							
8. (List organizations of second vehicle, if they differ from item 7 above)							
N/A							
9. BASE AND COMMAND SUBMITTING REPORT (Do not Abbreviate)  Det 1, 1129th SAS P.O. Box 882 Las Vegas, Nevada							
<b>10. LIST OF PERSONNEL DIRECTLY INVOLVED</b>							
(For aircraft include operator and all other persons whether in plane or not. If more space is required to list all personnel, use additional sheet(s).)							
Last Name	First Name	M.I.	Grade	Service No.	Assigned Duty	Aero Rating	Injury to Individual
			Civ	-	Test	Pilot	N/A
	25X1A						
11. NARRATIVE DESCRIPTION OF ACCIDENT: Give a detailed history of flight, or chronological order of facts and circumstances leading to the mishap as applicable, the results of investigation and analysis to include discussion of all cause factors listed, findings, and recommendations, and any corrective action taken. (Continue on reverse, if more space needed.)							
<p>A. Coordinating Group Report (Tab "A") as follows:</p> <ol style="list-style-type: none"> <li>1. History of Flight</li> <li>2. Investigation and Analysis</li> <li>3. Findings</li> <li>4. Recommendations</li> </ol> <p>B. The following detailed Group Reports are (Tab "W")</p> <ol style="list-style-type: none"> <li>1. Operations and Witness Gp</li> <li>2. Structures, Fire and Explosion Gp</li> <li>3. Power Plant and Fuel System Gp</li> <li>4. Electronics and Electrical Gp</li> <li>5. Life Sciences Gp</li> <li>6. Air Conditioning and Pressurization Gp</li> <li>7. Maintenance and Records Gp</li> <li>8. Automatic Flight Control and Air Data Systems Gp</li> <li>9. Hydraulic Systems Gp</li> <li>10. Flight Control System Gp</li> </ol>							
<b>12. AUTHENTICATION</b>							
CERTIFICATION BY (Title)		TYPED NAME AND GRADE		SIGNATURE		DATE	
Recorder		RICHARD ROUSSELL, Capt.		<i>Richard J Russell</i>		28 Jul 64	

AF FORM 711 DEC 62

PREVIOUS EDITION OF THIS FORM IS OBSOLETE.

U.S. GOVERNMENT PRINTING OFFICE : 1962 OF-669567

OXGART SECRET

**OX CART      SECRET**

## A. History of Flight

25X1A

On 9 July 1964 Lockheed test pilot [REDACTED] was scheduled in A-12 Aircraft number 133 for a maximum A/B climb to Mach 2.8 and sustained flight at Mach 2.8 and 78,000 feet. Route to be flown was Copper Bravo route (Photo 4844). Weather was better than usual and was not a factor in this accident. Aircraft inspection and personal equipment hook-up was performed by qualified ground crews in accordance with flight handbook and organization procedures. Take-off at 0820 PDT was normal (210K and 7400 feet ground roll with aircraft weight 112,000 pounds). An F-101, No. 312, piloted by Col R. J. Holbury and Capt R. J. Roussell was to be used for chase within the capabilities of the aircraft. After take-off chase advised that number 133 was clean and smooth. Both aircraft checked in with Bungalow, who advised good IFF/SIF contact. [REDACTED] performed maximum A/B climb to 78,000 feet and 2.8 Mach. At the northern limit of Copper Bravo route the pilot turned left and began the southbound leg. Onion slicers were closed down below 30 percent as planned. (This action is normally used to reduced turbulence in the intake duct.) The left shock popped at this time. (Primary shock wave moved forward out of the engine duct.) The "A" yaw stability augmentation system was lost also and could not be recovered. Since "B" yaw system was normal no flight plan change was required. The Pilot lost A/B on the left engine but was able to relight. After relight thrust was down on the left side but operation of the by-pass doors, onion slicers and spike (movement of spike is used to recapture the shock), returned the thrust to normal. "A" yaw system remained out. The pilot accelerated to 2.8 mach and headed for home base with the engines performing smoothly. Upon arrival in the local area a total of 35 minutes had been accomplished at mach 2.8. [REDACTED] was joined by the chase aircraft while descending in a left turn over the station at 28,000 feet. During a high down wind at 16,000 feet, base leg at 12,000 feet and turn onto final approach, all appeared normal. After aircraft 133 had been straight on a descending final for about one mile, altitude about 500 feet, airspeed approximately 200 knots the aircraft began a smooth steady roll to the left. The pilot applied full right elevon and added power but the aircraft continued its steady roll to the left. At approximately 45 degree bank and 200 feet altitude [REDACTED] ejected. The aircraft continued its left roll, struck the ground inverted, exploded and burned. After landing the pilot was dragged towards the crash fire but finally managed to spill the chute. He did not attempt to use the quick release mechanism on his parachute. He noted a rush of oxygen through the open face plate of his pressure suit. All personal equipment performed as designed. The mobile control officer arrived on the scene followed closely by medical and fire fighting personnel. The pilot was evacuated immediately for medical check up.

25X1A

25X1A

**OX CART      SECRET**

## B. Investigation and Analysis

1. After several days of careful examination of all available data it was determined the following areas (group reports attached) had no bearing on the accident:

- a. Electronics and Electrical.
- b. Life Sciences.
- c. Air Conditioning and Pressurization.
- d. Maintenance.
- e. Automatic Flt Control and Air Data Systems.
- f. Hydraulics systems, other than flight controls.

2. Operation, Power Plant and Flight Control Systems still remained suspect areas and the following possibilities were investigation in detail:

a. Engine explosion or failure in flight. (Negated by factual data from Power Plant Group that engines were operating at full military RPM and 80% thrust. Structures group indicated all damage in engine area was caused by aircraft impact.)

b. Pilot flying final approach too slowly resulting in stall and wing roll-off. (Negated by pilot statements, statements regarding airspeed made by the chase pilot, relative flying characteristics of the A-12 and F-101 and the aircraft impact speed).

c. Abnormal rudder trim operation. (Negated by structures report indicating both actuators were in a similar position at impact.)

d. Flight control problems.

(1) Investigation revealed that the position of the right outboard elevon was full down on impact. Further investigation was then centered on determining how this condition could have occurred. The right outboard elevon servo valve was subjected to exhaustive tests at Lockheed-Burbank and it was determined that binding had definitely occurred. This particular valve apparently incurred warpage in operational use as evidenced by burnishing on the valve wall. The described warpage caused the valve to bind but not to a degree that would prevent the elevon mechanical transmission system from overcoming it. However, oil samples revealed contamination within the servo valves, probably the result of metal chips accumulated during manufacture. This contamination would add to the drag caused by warpage. Additionally it was concluded that because of a rapid change in flight conditions, the valve was subjected to a temperature shock condition that further aggravated the the warpage. From the foregoing it was concluded that the metering spool in the right outboard elevon servo did bind to such a degree that it could

**OX CART SECRET**

not be overcome by the mechanical transmission system with its nominal force of 136 pounds. The binding of the metering spool allowed passage of fluid under pressure to the right outboard elevon actuators. This pressure gradually lowered the right outboard elevon to the full down position (20°) which in turn created a left rolling tendency which was beyond the capability of the roll system to counteract.

(2) The final portion of the investigation involved correlating the above facts with those reported by the pilot. The following analysis of events leading up to the crash of A/C 133 is based on the conclusion that the right outboard elevon servo failed.

(a) Taking the evidence available after the crash, the pilots statement and various witness reports, the following sequence of events can be established:

1. The pilot made a right turn on to final approach for landing after a relatively rapid spiral descent from a flight condition of Mach 2.8 and 78,000 feet. During the descent at approximately .8 Mach and 300 KEAS the gear was extended for the purpose of increasing rate of C.G. control during landing.

2. On final approach, in excess of one mile from the end of the runway, airspeed was bled off to approximately 200 KEAS. Rate of descent during final was reported to be higher than usual. Low throttle settings were reported used during final approach.

3. A slight roll off to the right was corrected by the pilot with a left roll input. The aircraft then started to roll left. The pilot started applying a slow aileron input to correct the left roll.

4. At least in the initial statement the pilot felt that he had initially checked or slowed the roll. At no time did the pilot note deviations from 1 "g" flight. Due to the roll condition the pilot considered a go around and started applying throttle.

5. Almost simultaneously with throttle movement he hit the aileron stick travel limit. With no control in roll he ejected at approximately 200 feet altitude from the steeply banked aircraft. The aircraft continued to roll and is estimated to have impacted inverted at an attitude of approximately 216 degrees of left bank with the right wing tip first contacting the ground.

(b) The flight recorder was destroyed on impact and no evidence could be obtained from it. Evidence obtained from the wreckage indicates the following conditions existed on impact:

**OX CART SECRET**



**OXOART SECRET**

3 The aircraft controls were trimmed to approximately zero in roll and yaw and 2.4 degrees trailing edge up on the inboard elevons in pitch.

4 The nose of the aircraft hit slightly after the wing tip indicating that the aircraft was probably at a slight nose up attitude. Unfortunately no film was being taken of the landing.

(c) Reviewing the events, evidence and pilots comments presented above it can be concluded that the right outboard elevon valve jammed in a partially open condition. It is apparent that the valve did not jam full open. Had this occurred the elevon would have been moving at 30 degrees per second and the pilot would have lost roll control in .29 seconds and had a full down right elevon condition in .85 seconds. This was not the case, however, for the pilot stated he applied corrective action slowly. In addition, the pitch transient would have been quite severe. The lack of comment on a severe pitch transient and the slow input of corrective aileron establishes the fact that initially the control surface was drifting to the full down position slow enough to be well within the pilots capability to apply corrective action. The action of the pilot then to correct for a right roll-off or possibly a small pitch or roll damper input would be sufficient to crack the valve to an open position where it could jam. This would result in driving the right outboard elevon to the full down position in which it was found. When the pilot ejected, the stick returned to neutral position. Thus the aircraft went out of control in both roll and pitch. The roll rate should increase to approximately 41 degrees per second and a large nose down pitching movement would be applied. This nose down movement applied to the inverted aircraft would explain why the aircraft impacted in an almost flat to slightly nose high attitude.

#### C. Findings

1. The primary cause of this accident was that the outboard elevon servo valve stuck in the partially open position causing the right outboard elevon to gradually move to the full down position. This imparted more left roll to the aircraft than could be overcome by the pilot. The sticking of this valve resulted from the combination of three conditions; warpage of the valve incurred in operational use, a temperature shock condition due to a rapid change in flight conditions and metal particles within the servo valve probably accumulated during manufacture.

2. The designed clearance between the metering spool and the valve body of the servo units is necessarily small accentuating the consequences of contamination, manufacturing tolerances, temperature changes, or other outside influences. This fact coupled with the relatively light force capable of being exerted by the elevon mechanical transmission system (136 lbs.) increases the possibility of a malfunction.

#### D. Additional Findings not Contributing to the Accident:

1. The flight recorder was destroyed on impact. In addition it did

**OXOART SECRET**

**OXCAPT SECRET**

not have a sufficient number of parameters to provide a meaningful and complete flight data history.

2. A-12 aircraft take-offs and landings were not being filmed.

3. After activation of the emergency oxygen system opening of the face visor of the pressure suit activated rapid flow of emergency oxygen about the pilots face creating a fire hazard.

E. Recommendations:

1. It is recommended that:

a. The diametrical clearance between the metering spool and valve body be increased sufficiently to minimize the possibility of binding; however, an adequate seal to prevent hydraulic fluid seepage between systems must be retained.

b. The servo valve assemblies be subjected to a temperature shock environment in order to stabilize all components in the main metering valve prior to a functional test.

c. All preliminary functional and temperature shock tests be conducted with the servo input filters in place but the output filters removed. This will clean the valves of contaminants incurred during manufacture. Output filters should be installed prior to final high temperature functional test.

d. The elevon mechanical transmission system from the inboard elevon to the summing lever of the outboard servo be strengthened in order to overcome and operate a binding spool should it occur.

e. An on-off valve be incorporated into the pilots helmet visor control to insure there is no flow of oxygen when using emergency system with the face plate open.

f. A more modern flight recorder be procured that will better withstand crash damage.

g. All A-12 aircraft take-offs and landings be filmed. Processing need not be accomplished unless the requirement exists.

F. Action Taken:

1. Action recommended in a,b,c and d above has been initiated and will be completed before aircraft are returned to flight status.

2. Necessary equipment has been ordered for compliance with recommendation "g".

**OXCAPT SECRET**

**OXCAR** **SECRET**

The above findings and recommendations were drafted and approved by the following members of the board.

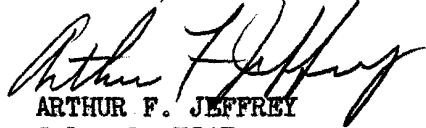

ARTHUR F. JEFFREY  
Colonel, USAF  
Board President



FREDERICK C. BLESSEE  
Lt Col, USAF  
Coordinating Group



JOHN R. KELLY JR.  
Lt Col, USAF  
Coordinating Group



EDWARD F. MARTIN JR.  
Coordinating Group



NORMAN E. NELSON  
Coordinating Group

**OXCAR** **SECRET**

TAB

**SECRET**

AIRCRAFT ACCIDENT/INCIDENT REPORT									
To be filled out for principal aircraft involved. (Appropriate blocks only should be filled out on secondary aircraft.)									
1. ACCIDENT/INCIDENT CLASSIFICATION (Check one)									
Flight Accident Resulting in Aircraft Damage <input checked="" type="checkbox"/> Major <input type="checkbox"/> Minor					Accident Not Resulting in Aircraft Damage <input type="checkbox"/> Major <input type="checkbox"/> Minor				
Aircraft Non-flight Accident <input type="checkbox"/> Major <input type="checkbox"/> Minor					Air Force Aircraft Incident <input type="checkbox"/> Major <input type="checkbox"/> Minor				
2. Aircraft/Serial Number 60-6939 / 133		3. Type, Model, Series, Block No. A-12			4. Assignment/Status Code (AFM 65-110) Test				
5. If aircraft was being ferried or delivered indicate gaining and losing organizations, date of transfer, ultimate destination. N/A 25X1A									
6. From [Redacted] To Round Robin									
7. Filed: VFR <input checked="" type="checkbox"/> VFR-ON TOP <input type="checkbox"/> IFR <input type="checkbox"/> Local <input checked="" type="checkbox"/> Other <input type="checkbox"/> Direct <input type="checkbox"/> Airways <input type="checkbox"/> (Controlled)									
8. Flight reference at time of accident				9. Duration of Flight Hrs. 1 Mins. 10		10. Mission of flight Max A/B climb Sustained Flight at 2.8 M			
11. ALTITUDE DATA Cleared Alt. MSL VFR Ft. 400		Altitude above terrain acdt sequence began 400 Ft.		Altitude MSL impact point 4463 Ft.		Highest altitude MSL flown 78,000 Ft.		Time flown highest alt. Hrs. 0 Min. 35	
12. Fire and explosion data a. Fires: None <input type="checkbox"/> Inflight <input type="checkbox"/> Ground <input checked="" type="checkbox"/> Result of grd. impact? Yes <input checked="" type="checkbox"/> No <input type="checkbox"/> b. Explosions: None <input type="checkbox"/> Inflight <input type="checkbox"/> Ground <input checked="" type="checkbox"/> Result of grd. impact? Yes <input checked="" type="checkbox"/> No <input type="checkbox"/>		13. Airfield data: Applicable to takeoff and landing accidents occurring within 2 miles of airfield Field elevation in use 4,463 Ft. Composition of runway Asphalt <input checked="" type="checkbox"/> Concrete <input checked="" type="checkbox"/> Length of runway in use 14,625 Ft. Other (Specify) _____ Length of overrun 4,805 Ft. Composition of overrun (Specify) Asphalt Distance of touchdown from runway 5,388 Ft. Surface condition Dry <input checked="" type="checkbox"/> Wet <input type="checkbox"/> Icy _____ Heading of runway 321 ° Other (Specify) _____ Conditions affecting occurrence; e.g., type of instrument or lighting approach aid used, obstructions, barrier, airspeed, gross weight, forced landing							
14. (If answer is "Yes," to either question, discuss under item 11, AF Form 711) Violations <input type="checkbox"/> Yes <input checked="" type="checkbox"/> No Breaches of air discipline <input type="checkbox"/> Yes <input checked="" type="checkbox"/> No									
15. PHASE OF OPERATION: e.g. take off roll, initial climb, normal flight, acrobatics, landing approach, flareout Landing Approach					16. TYPE OF ACCIDENT: e.g. gear-up landing, mid-air collision, abandoned aircraft, fire or explosion in flight, undershoot, overshoot Flight Control Malfunction				
17. WEATHER AT TIME AND PLACE OF ACCIDENT: (If a factor in the accident, attach statement of weather officer) Sky conditions 14,000 Scattered 15 miles Visibility 15 miles Wind direction and velocity 190/10+13 Temperature 81° Dew point 47 Alt. setting 30.05 Other weather conditions									
18. OPERATOR (Person at controls at time of accident) PILOT(S) INVOLVED (FLIGHT CREW)									
a. LAST NAME (Jr., II, etc.) FIRST NAME MIDDLE NAME			GRADE COMPONENT		SERVICE NUMBER		NATIONALITY		YR. OF BIRTH
[Redacted]			Lockheed		N/A				
b. POSITION IN AIRCRAFT AT TIME OF ACCIDENT			c. ASSIGNED DUTY ON FLIGHT ORDER						
Front or Left Seat <input checked="" type="checkbox"/> Rear or Right Seat 25X1A			AC <input type="checkbox"/> IP <input checked="" type="checkbox"/> P <input checked="" type="checkbox"/> CP <input type="checkbox"/> Other (Specify) _____						
d. ASSIGNED ORGANIZATION									
Major Command	Subcommand or AF	Air Division		Wing	Group		Squadron or Unit		Base
N/A									
e. ATTACHED ORGANIZATION FOR FLYING									
Major Command	Subcommand or AF	Air Division		Wing	Group		Squadron or Unit		Base
f. ORIGINAL AERONAUTICAL RATING AND DATE RECEIVED			g. PRESENT AERONAUTICAL RATING AND DATE RECEIVED			h. INSTRUMENT CARD		i. AFSC	
N/A						Type _____ Date of expiration _____		Primary _____ Duty _____	
19. OTHER PILOT									
a. LAST NAME (Jr., II, etc.) FIRST NAME MIDDLE NAME			GRADE COMPONENT		SERVICE NUMBER		NATIONALITY		YR. OF BIRTH
N/A									
b. POSITION IN AIRCRAFT AT TIME OF ACCIDENT			c. ASSIGNED DUTY ON FLIGHT ORDER						
Front or Left Seat _____ Rear or Right Seat _____ Other _____			AC _____ IP _____ P _____ CP _____ Other (Specify) _____						
d. ASSIGNED ORGANIZATION									
Major Command	Subcommand or AF	Air Division		Wing	Group		Squadron or Unit		Base
e. ATTACHED ORGANIZATION FOR FLYING									
Major Command	Subcommand or AF	Air Division		Wing	Group		Squadron or Unit		Base
f. ORIGINAL AERONAUTICAL RATING			g. PRESENT AERONAUTICAL RATING			h. INSTRUMENT CARD		i. AFSC	
						Type _____ Date of expiration _____		Primary _____ Duty _____	

NOTE: IF MORE THAN TWO PILOTS ARE INVOLVED (FLIGHT CREW) REPORT SAME INFORMATION REQUIRED ON ADDITIONAL SHEET FOR EACH.

AF FORM 711b DEC 62

PREVIOUS EDITION OF THIS FORM IS OBSOLETE.

**OXCAR**

**SECRET**

20. FLYING EXPERIENCE (Attach copy of AF Form 5 for Pilot(s) involved as outlined in AFR 127-4.)					
ASSIGNED DUTY ON FLIGHT ORDERS: (Give last names only. List all flight times to nearest hour.)	Pilot	Co-Pilot	Inst. Pilot	Acft. Cmdr.	Student Pilot
	a. Total flying hours (Including AF time, student and other accredited time):	5000+			
b. Total Jet Time:	N/A				
c. Total 1st Pilot/IP hours, all Aircraft:	N/A				
d. Total Weather Instrument Hours:	N/A				
e. Total 1st Pilot/IP hours this Model:	148:00				
f. Total 1st Pilot/IP hours last 90 Days:					
g. Total 1st Pilot/IP hours last 90 Days this Model:					
h. Total 1st Pilot/IP hours weather and hood last 90 Days:	18:45				
i. Total Pilot hours night last 90 Days:	N/A				
j. Total Pilot hours last 30 Days:	N/A				
k. Total 1st Pilot/IP hours last 30 Days:	N/A				
l. Total 1st Pilot/IP hours last 30 Days, this Model:	6:15				
m. Date and Duration last previous flight this Model:	8 Jul 64 (1:00)				
n. Date of last proficiency flight check:	N/A				

21. CAUSATIVE AGENCY						
Cause Factors (Check one primary and all applicable contributing and probable factors.)				Primary	Contributing	Probable
	Primary	Contributing	Probable			
<b>Operators</b>				<b>Other Personnel</b>		
Pilot				(Specify) _____		
Co-Pilot						
Controller (Drones)				<b>Material Failure or Malfunction</b>		
<b>Crewmembers (Other than Operator)</b>				Engines	<input checked="" type="checkbox"/>	<input checked="" type="checkbox"/>
(Specify) _____				Airframe	<input checked="" type="checkbox"/>	<input checked="" type="checkbox"/>
				Landing Gear		
<b>Supervisory Personnel</b>				Other (Specify) _____		
(Specify) _____						
<b>Maintenance Personnel</b>				<b>Airbase or Airways</b>		
Type of pers. and orgn. level				Weather		
				Misc. Unsafe Conditions		
				(Specify) _____		
				Undetermined <input type="checkbox"/>		

22. DAMAGE			
Damage to Aircraft	Damage Beyond Economical Repair	Manhours to Repair	Cost (Est.)
<input checked="" type="checkbox"/> Destroyed <input type="checkbox"/> Substantial	<input type="checkbox"/> Yes <input type="checkbox"/> No		\$
Description of Damage (Describe briefly extent of damage to aircraft and any property damage incurred)			
Aircraft totally destroyed (See Tab U) No damage to private property (See Tab T)			

23. AUTHENTICATION (Signature and grade)	
President <i>Arthur J. Jeffery Col</i>	Accident Investigation Officer <i>Jedemick G. Blaser Lt Col</i>
Maintenance Officer <i>John R. Kelly Lt Col</i>	Medical Officer <i>Ray Phary Jr Maj for Bruce K Kimbel</i>
AACS Representative N/A	AACS Representative N/A
Member N/A	Recorder <i>Richard J. Russell Capt</i>

TAB

**OXCART SECRET**

AIRCRAFT MAINTENANCE/MATERIEL REPORT							
Use this form when AF aircraft accident/incident involves inadequacy, malfunction or failure of AF materiel.							
<b>1. AIRCRAFT TM &amp; SERIAL NUMBER</b>  A-12 S/N 133		<b>2. SPECIAL REPORTS DATA</b> a. Were Previous UR's Submitted on Factor(s) Involved? <input type="checkbox"/> Yes <input checked="" type="checkbox"/> No					
		b. No. and Date of UR's Submitted as Result of This Accident (Attach copy)  N/A		d. No. of T.O.'s Not Complied With at Time of Accident (List T.O. Nos. and titles on separate sheet(s)—Tab K) See Maintenance, Inspection and Records Group Report			
		c. Is TDR Requested? <input type="checkbox"/> Yes <input checked="" type="checkbox"/> No					
3. AIRCRAFT HISTORICAL DATA							
Item	Aircraft	Part, Component or Accessory					
Identification of Aircraft/Part, etc.	A-12						
Air Force Acceptance Date	27 May 64						
Total Flight Hours	07:09	(Prior to last flight)					
Last Overhaul Date	N/A						
Overhauling Activity (Name and location)	N/A						
Hours Since Overhaul	N/A						
Hours Since Last Periodic Inspection	N/A						
Date of Last Periodic Inspection	9 July 1964						
Type of Last Periodic Inspection	Pre-Flight						
4. ENGINE HISTORICAL DATA							
(Complete a separate column for each engine involved. Also, complete a separate column for each power plant component involved.)							
Installed Position	Left	Right					
Engine Model and Series	YJT11D-20A	YJT11D-20A					
Engine Serial Number	P648222	P648234					
Total Engine Hours	80:23	40:47					
Number of Major Overhauls	0	1					
Hours Since Last Major Overhaul	N/A	18:04					
Date of Last Overhaul	N/A	30 Apr 64					
Overhaul Activity	N/A	P&WA					
Date Last Installed	26 Jun 64	13 Jun 64					
Hours Since Last Installed	05:05	09:42					
Date of Last Periodic Inspection	9 Jul 64	9 Jul 64					
Type of Last Periodic Inspection	Pre-Flight	Pre-Flight					
Fuel (Type and octane rating)	PF-1	PF-1					
5. FIRE DATA							
(To be completed when fire or chemical explosion occurs, not resulting from ground impact. Indicate: P—Probable or K—Known, in squares below.)							
a. MATERIEL FAILURE CAUSING THE FIRE		b. IGNITION SOURCE			c. COMBUSTIBLE MATERIAL		
Electrical System	Propulsion System	Electrical System	Static Electricity/Lightning	Cargo	Hydraulic Fluid		
Fuel System	Other (Specify)	Pneumatic System	Other (Specify)	Electrical Insulation	Lubricating Oil		
Hydraulic System		Propulsion System		Explosives	Other (Specify)		
Pneumatic System	Unknown		Unknown	Fuel	Unknown		
d. AIRCRAFT FIRE EXTINGUISHING SYSTEM				e. FIRE/OVERHEAT WARNING			
	Fixed	Portable	Fixed	Portable	Fire Detector		Overheat Indicator
Extinguished Fire			Not Activated and Not Near Fire		Operated Properly		
Reduced Fire			If Discharged, Chemical Used		Not Operated, but Near Fire		
No Effect When Discharged			If Discharged, Amount of Chemical Used		Not Operated and Not Near Fire		
Activated but Did Not Discharge			Other Pertinent Info.		Not Installed		
Not Activated but Near Fire					Other (Specify)		
f. SHUT OFF PROCEDURE		RESULTS OF ALLOWING FIRE TO BURN OUT			g. EFFECT OF FIRE		MARK ONE
Extinguished Fire					Catastrophic		
Reduced Fire					Increased Severity of Mishap		
No Effect					No Change in Severity of Mishap		
Not Accomplished					Unknown		
Unknown							

AF FORM DEC 62 711c

PREVIOUS EDITION OF THIS FORM IS OBSOLETE.

**OXCART SECRET**



**OX CART SECRET**

6. LOCATION OF INITIAL FIRE								
	Known	Probable		Known	Probable		Known	Probable
Baggage Compartment			Aft of Firewall			Wheel Well		
Bomb Bay			Forward of Firewall			Cargo-Passenger Compartment		
Cockpit/Crew Quarters			Rocket Pod			Other (Specify)		
Engine Section			Tire/Wheel/Brake			Unknown		<input type="checkbox"/>

7. MISCELLANEOUS CHEMICAL EXPLOSION DATA					
	Known	Probable		Known	Probable
Initial Ignition Occurred in an Explosive Manner Prior to Ground Impact.			Intensity of Explosion Was Sufficient To Cause or Appreciably Contribute to In-Flight Airframe Break-Up.		
Explosion Occurred After Fire and Before Ground Impact.			Other Significant Data (Specify)		
Explosion Occurred Subsequent to Ground Impact.			Unknown or Not Available.		

**8. AIRCRAFT MAINTENANCE OFFICER'S ANALYSIS AND SPECIFIC ACTION TAKEN**  
 Describe difficulties involved and relationship of the various components to the accident. Describe specific action taken. For Fire Data describe the fire and/or chemical explosion. Cover in detail any noted deficiencies, malfunctions of fire detecting and extinguishing equipment, or questionable procedures. When discussing specific equipment, give the name of manufacturer, part numbers, etc., and state whether or not a UR has been submitted. Include any additional information or opinion of possible value to future technical analysis of this report.

Covered in other specialized reports.

**OX CART SECRET**

TAB

**SECRET**

**LIFE SCIENCES REPORT OF AN INDIVIDUAL INVOLVED IN AN AF ACCIDENT/INCIDENT  
SECTION A. AIRCRAFT ACCIDENT/INCIDENT**

25X1A

1 GENERAL									
a. Name, Grade, Serial No.			b. Assigned Base and Command <b>Lockheed Aircraft Corp</b>			c. Aircraft Type, Model, Series (as applicable) <b>A-12</b>			
d. [Redacted]			h. Height <b>67 3/4</b>	i. Weight <b>170</b>	j. Years of Educ. <b>--</b>	k. Activity at time of Accident/Incident <b>Pilot</b>			
2 MEDICAL DATA									
a. Degree of Injury: None <input type="checkbox"/> Minor <input checked="" type="checkbox"/> Major <input type="checkbox"/> Fatal <input type="checkbox"/> Missing <input type="checkbox"/>			b. Days Hospitalized <b>0</b>	c. Days in Quarters <b>0</b>		d. Total Days to be Lost <b>0</b>			
e. Waiver Yes <input type="checkbox"/> No <input checked="" type="checkbox"/> Specify _____			f. If Fatal: Was Autopsy Form Submitted to AFIP? Yes <input type="checkbox"/> No <input type="checkbox"/> Were Specimens Submitted to AFIP? Yes <input type="checkbox"/> No <input type="checkbox"/> Frozen <input type="checkbox"/> Fixed <input type="checkbox"/>						
g. Diagnosis: Describe Fatalities, Injuries and Causes (Use Basic Diagnostic Nomenclature, AFR 160-13). Specify Primary Injury in non-fatal or primary cause of death in fatal. <b>[Redacted]</b>									
3 PHYSIOLOGICAL INCIDENT (Complete Items 1, 2, 3, 4, 5, 6, 7, and 10 as applicable)									
a. Type Mission <b>Test</b>		b. Duration of Flight <b>110</b>		c. Single Ship <input checked="" type="checkbox"/> Formation <input type="checkbox"/>		d. Ind. Alt at time of inc. <b>Est 200 ft</b>			
e. Cabin Alt at time of inc. <b>Same</b>		f. Time at Alt. <b>1</b> hrs.		Aircraft Pressurization ground checked on <b>See airconditioning-Pressurization Rpt</b>					
g. Did you use O <sub>2</sub> Preflight? Check: Yes <input checked="" type="checkbox"/> No <input type="checkbox"/>		h. Regulator Setting Type Regulator Used <b>Special</b>		i. Oxygen System Pressure at takeoff: <b>90 psi (LOX)</b>		at time of incd: <b>System off</b> Capacity <b>10 liters</b>			
j. Last Check of O <sub>2</sub> System on <b>8 July 64</b>		k. Type of Mask <b>Pressure only</b>		Adequate Fit: Yes <input checked="" type="checkbox"/> No <input type="checkbox"/>		l. Time Lapse between incident and examination <b>One hour</b>			
m. Specify Tests (Specify Type and Results): <b>None</b>									
CO		Blood Sugar		High		CO <sub>2</sub>			
n. Attach a diagram of the flight profile involved, use additional sheet(s)									
4 PSYCHOPHYSIOLOGICAL FACTORS									
Check only factors present. Explain the basis for your determination in Item 10. Cite all clinical and lab evidence									
FACTOR	Not Sig	CONTRIBUTED TO ACCIDENT			FACTOR	Not Sig	CONTRIBUTED TO ACCIDENT		
		Definite	Probable	Possible			Definite	Probable	Possible
Aging					Preoccupation/Channelized Attention				
Alcohol					Other				
Air Sickness					Fatigue				
Auditory Interference					G-Forces				
Body Build					Hyperventilation				
Boredom					Hypoxia				
Cardiovascular					Illness				
Discipline					Language Barrier				
Distraction					Missed Meals				
Drugs and/or Self-Medication					Motivation/Morale				
Dysbarism (Specify)					Spatial Disorientation				
Emotional Disturbances					Task Over-saturation				
Anxiety					Unconsciousness				
Fear					Vertigo				
Get-Homeitis					Visual Restriction				
Irrational Behavior					Other Related Factors (Explain)				
Over Confidence					No Factors Present	<input checked="" type="checkbox"/>			
Panic									
5 ENVIRONMENTAL FACTORS (Check only factors present. Explain the basis for your determination in Item 10. Cite all clinical and lab evidence)									
FACTOR	Not Sig	CONTRIBUTED TO ACCIDENT			FACTOR	Not Sig	CONTRIBUTED TO ACCIDENT		
		Definite	Probable	Possible			Definite	Probable	Possible
Air Pressure, i.e. Rapid Decompression, Pressure Loss, Etc., Specify					Smoke, fumes				
Cold					Vibration				
Deceleration Forces					Weather				
Heat					Windblast				
Light Intensity					Other Related Factors, Specify				
Noise					No Factors Present	<input checked="" type="checkbox"/>			
6 TRAINING RELATED TO THIS ACCIDENT/INCIDENT (Give Dates Accomplished)									
a. Ejection Seat Training: Seat Simulator _____ Ejection Seat Tower _____ Previous Ejection <b>Yes</b>					HOURS				
Lectures/Demonstrations <b>Oct 1963</b> Other (Explain) _____					Total Flying Time <b>5000 plus</b>				
					This model <b>148</b>				
b. Survival Training: USAF School: Ground _____ Water _____ Arctic _____ Jungle _____ Lectures/Demonstrations _____ Other _____									
c. Parachute Training: Jump School: _____ Nr. Previous Jumps <b>1</b> Lectures/Demonstrations _____ Other _____									
d. Physiological Training Date <b>January 1961</b> Place <b>Lockheed</b>			e. Last Chamber Flight Date <b>December 61</b> Place <b>Buffalo, NY</b>			f. Type Flight <b>Full pressure indoctr.</b>			
g. AFSC or Other Training <b>NA</b>		h. Name of Course or OJT		i. Dates Attended		j. Aptitude Scores Applicable			

**SECRET**

**XCART SECRET**

7 PERSONAL, PROTECTIVE AND SURVIVAL EQUIPMENT						
Specify all applicable items of equipment on appropriate line and specifically indicate all types of clothing worn and any other equipment that influenced operation.				NOT AVAILABLE	AVAILABLE	
ITEM	EXAMPLE	TYPE	Not Used		Used Functioned	Failed
Head Protection	P-4B, HGU-2/P, HGU-6/P	Full pressure			X	
Eye Protection	Visor, <b>XCART</b>	Helmet visor(Open)	X			
Ear Protection	Ear Plugs, Muff	Helmet earphones		X		
Oxygen Mask	MBU-5/P MBU-3/P	Helmet supply	X			
Clothing Worn	K-2B, A/P-22S-2	Full pressure suit		X		
Clothing, Survival	Sleeping Bag, Down-Filled Suit	Full survival kit	X			
Gloves	B-3A, MG-1	Pressure suit gloves		X		
Footgear	Alert Boots, Combat Boots	Special boots		X		
Body Restraints	Seat Belt, Shoulder Harness	Seat belt, shoulder harness, foot rest.		X		
Life Vest	LPU-2/P	Built insuit	X			
Life Raft	PK-2, E-2B	NAVA	X			
Survival Kit, Container	Global, MD-1	MD-1	X			
Communications	URC-11, SARAH	URC-11	X			
Other Signaling Devices	Flares, Mirrors, Whistle	All	X			
Rations	Food/Water, Provided/Foraged	All	X			
Survival Equipment	Rifle, Fishing Gear	Full kit	X			
Seat	Fwd/Rear Facing, Side, Fixed, Etc.	F-104 type rocket			X	
Other Equipment	Flashlight, etc. (Specify)	----				

**8 ESCAPE**

a. General: (Check or fill in as appropriate)

Ejection  Ground  Flat  Mtns  Ice/Snow  Hilly  Desert  Wooded  Swamp  Other (Exp) \_\_\_\_\_

Landing Surface: Water  Calm, Shallow  Deep  Rough, Shallow  Deep  Unknown

b. Surface Winds, Knots **10 to 13** (estimate if unk) Dragged: Yes  No  Difficulty releasing Chute Canopy: Yes  No

c. Reason for Jump (if more than one indicate):  
Fuel Exhaustion \_\_\_\_\_ Fire \_\_\_\_\_ Engine Failure \_\_\_\_\_ Mid-Air Collision \_\_\_\_\_ Loss of Control  Other (Exp) \_\_\_\_\_

d. Altitude of Aircraft: Level \_\_\_\_\_ Inverted \_\_\_\_\_ Dive \_\_\_\_\_ Bank  Spin \_\_\_\_\_ Spiral \_\_\_\_\_ Climb \_\_\_\_\_ Other (Exp) **More level, left bank of more than 45°, less than 90°**

e. Altitude above Surface **Est 200ft. 200 X** (if not known, approx.) Seat Catapult: Ballistic \_\_\_\_\_ Rocket

f. Difficulties Initiating Escape: **None**  
Centrifugal Force \_\_\_\_\_ Canopy/Hatch Failure \_\_\_\_\_ Injury \_\_\_\_\_ Actuating Controls (Specify) \_\_\_\_\_ Other (Exp) \_\_\_\_\_

g. Difficulties During and After Escape:  
Clothing/Equipment Interference \_\_\_\_\_ Seat entangled in Shroud Lines \_\_\_\_\_ Legs/Arms entangled in Shroud Lines  Automatic Lap Belt Malfunction \_\_\_\_\_  
Held onto Seat Actuating Controls \_\_\_\_\_ Did not Separate \_\_\_\_\_ No Diff \_\_\_\_\_ Other (Exp) \_\_\_\_\_

h. Seat Separation Device Installed: Yes  No \_\_\_\_\_ Functioned Properly: Yes  No \_\_\_\_\_  
Failed: Webbing \_\_\_\_\_ Initiator \_\_\_\_\_ Other (Exp) \_\_\_\_\_

i. Type Parachute: Seat \_\_\_\_\_ Back \_\_\_\_\_  
Canopy release: Single  Double  **35'** Parachute equipped with Zero Delay Lanyard: **Special (Speed) Sensor** Yes \_\_\_\_\_ No \_\_\_\_\_ Connected to D-ring: **Special Configuration** Yes \_\_\_\_\_ No \_\_\_\_\_ Automatic Lanyard Connected: Yes  No \_\_\_\_\_

NOTE: A narrative statement will be prepared by each ejectee and/or survivor to include all information pertinent to escape and survival. The statement will be attached to this form. In the event of a fatality, the statement will be prepared by the Flight Surgeon.

**9 RESCUE AND/OR SURVIVAL**

a. Survival involved (Survival implies any water landing and anytime over 1 hour before rescue on land) Yes \_\_\_\_\_ No

b. Distance nearest Rescue (military base) **on base** NM Time before Rescue **2 minutes.** Transmitted distress signal: Yes \_\_\_\_\_ No   
Transmitted position fix: Yes \_\_\_\_\_ No

c. Effects of Exposure: Frostbite \_\_\_\_\_ Immersion \_\_\_\_\_ Sea Sickness \_\_\_\_\_ Insect Bites \_\_\_\_\_ Sunburn \_\_\_\_\_ Dehydration \_\_\_\_\_ Other (Explain) **None**  
Flares \_\_\_\_\_ Mirror \_\_\_\_\_ Flashlight \_\_\_\_\_

d. Primary Factor in Rescue: Radio/Beacon (Specify) **on base** Flares \_\_\_\_\_ Mirror \_\_\_\_\_ Flashlight \_\_\_\_\_  
Sea Marker Dye \_\_\_\_\_ Position Fix \_\_\_\_\_ Chaff \_\_\_\_\_ Local Population \_\_\_\_\_ Other (Specify) \_\_\_\_\_

e. Type Rescue: None Required  Ground Party, Military \_\_\_\_\_ Local Population \_\_\_\_\_ Helicopter/other Aircraft (Specify) \_\_\_\_\_  
Boat \_\_\_\_\_ Self Rescue (Walked Out) \_\_\_\_\_ Other (Specify) \_\_\_\_\_

**10 MEDICAL OFFICER'S RATIONALE, COMMENTS**

This section is to include comment on medical, personal, social, family, industrial hygiene and allied factors in incident causation, and a description and analysis of the factors in injury causation. Injuries should be correlated with the operations of personal equipment, malfunctions and failures of structures, systems, etc. Pertinent contributing factors in Items 3 through 9 should be commented upon. Include X-ray and laboratory findings. Pertinent recommendations are encouraged.

**The pilot was in good health, well qualified in the aircraft, and current on annual physical. While on final approach, in landing configuration, there occurred a loss of control. The aircraft began a roll to the left at (estimated) 200K and 200 feet altitude. The pilot ejected. The escape system functioned perfectly and he was essentially uninjured. [redacted] had opened his visor at 15,000 feet, turning off the oxygen system. He spent less than 1 minute descending to 10,000 feet. The visor may be open for landing because of reflectance problems, however, on ejection with activation of the emergency oxygen system, there occurred a rapid flow of oxygen about his face. Ignition by the rocket or landing near crash fire could have caused serious burns. On touchdown, [redacted] was being dragged toward the fire. He pulled on the risers to collapse the parachute because he was in "too much of a hurry to use the quick releases".**

Date **23 July 1964** Typed Name, Grade and Title of Medical Officer **BRUCE K. KIMBEL, Major USAF MC FS** Signature *Bruce K. Kimbel, Maj.*

COMMENTS: a. An on-off valve in the visor mechanism would preclude oxygen flow with the visor up.  
b. A pilot should be able to see through the visor if a fire is encountered, redesign should be accomplished. (SEE ATTACHED)

**XCART SECRET**

**OX CART**

**COMMENTS (Cont'd)**

c. A one-step ejection procedure saved this pilot's life. Any delay, as pulling the green apple, would have been fatal.

**OX CART** **SECRET**

TAB

Pilot Qualifications - [REDACTED]

25X1A

Total Flying Time - 5,000 hours plus

Total A-11/A-12 Time - 148 hours

Total A-11/A-12 - Time Last 6 Months - 39 hours

Total A-11/A-12 Time Last 30 Days - 6 hours 15 minutes

1. The last entry showing 6 hours 15 minutes is total time logged for eleven flights. Often, these pilots accelerate to Mach 3 and only log 45 minutes. This is added to show that 6 hours 15 minutes, without mentioning 11 flights and the average duration might lead one to believe that the pilot had not flown much in the last 30 days. Actually, 11 flights in 30 days is above average.

25X1A

2. [REDACTED] has worked for Lockheed as a test pilot since 1957 and prior to that was a test pilot for Convair. During testing of the F-104, this pilot logged a total of 518 hours.

25X1A

3. [REDACTED]'s records indicate that, among others, he has flown the following types of aircraft:

F-104A, F-104B, F-104J, F-104C, F-104G, XF-104, QF-104, F-86A, F-86D, F-86E, F-86F, F-102, YF-102, B-57A, B-57B.

25X1A

4. It has been established that [REDACTED] has repeatedly handled serious emergencies in the A-11/A-12 aircraft and it is the opinion of this group that he is an extremely well qualified test pilot thoroughly proficient in this A-11/A-12 Aircraft.

*Frederick C. Blesse*  
FREDERICK C. BLESSE, LtCol, USAF  
Directorate of Aerospace Safety  
Norton AFB, California

*Raymond L. Haupt*  
RAYMOND L. HAUPT  
LtCol, USAF  
Det 1, 1129th SAS

25X1A

[REDACTED]  
Experimental Test Pilot  
Lockheed Aircraft Corp.

[REDACTED]  
John [REDACTED]  
Aerodynamacist  
Lockheed Aircraft Corp.

25X1A

TAB



**SECRET**

25X1A Extract from taped testimony [redacted] concerning major aircraft  
Approved For Release 2001/08/29 : CIA-RDP71B00590R000100040001-1  
accident, SYN 155, 9 July 1964 at Det 1, 1129th SAS, Las Vegas, Nevada

25X1A VERBAL TESTIMONY OF PILOT [redacted] DATED 13 JULY 1964

25X1A

[redacted]  
As you were coming down on the final starting your flare, were you applying back pressure on the stick prior to this roll?

I was not in the flare, I was still descending. I was evidently trimming the pitch axis due to the deceleration but was not in the round-out phase of the landing.

At what point did you release your surface?

I pulled the surface limiter on base leg.

You don't feel that there might have been a transient due to the surface limiter since it was pulled before you turned on the final, do you?

I am sure there was no transient on the surface limiter operation.

Major Kimbel:  
25X1A

When you hit the stop, was it abrupt or soft with resistance?

Quite abrupt.

Kimbel:  
25X1A

What was your airspeed, altitude and attitude at time of ejection?

Airspeed 200 knots, altitude and attitude unknown.

Kimbel:  
25X1A [redacted]

What was the sensation during ejection?

Nothing specific except that I was tumbling and on landing the shroud lines became tangled when trying to spill the chute.

Kimbel:  
25X1A [redacted]

Did you notice an oxygen flow when you released the emergency oxygen hoses and parachute?

25X1A [redacted]  
Art Smith:  
25X1A

Yes because I noted a hissing noise.

Bill, do you recall how much power you applied after the roll started?

No, I did not notice.

**SECRET**

**OXGART SECRET**

Smith:

Did you notice a response to power being applied?

[REDACTED] 25X1A

Yes, I did.

25X1A

[REDACTED]

Did you notice any yawing that could be attributed to engines on the final? Also when you applied power?

25X1A

[REDACTED]

I did not.

Col Jeffrey:

Were you able to correct any for the roll after it started?

25X1A

[REDACTED]

No, I was not able, it continued on.

Col Jeffrey:

When you gave it right stick, did you feel any control response?

25X1A

[REDACTED]

No, none.

Col Blesse:

Bill, do you think you could have done better getting out of the chute harness with the old type harness release that is rotated 90° and pushed in?

25X1A

[REDACTED]

Probably, I could have done a little better, but the gloves are quite cumbersome and circumstances could make release with this type impossible.

Major Haupt:

Can you give an estimate on rate of descent in the pattern?

25X1A

[REDACTED]

I don't know what my rate of descent was but it was normal for the airspeed and the angle of the approach that I was making. Nothing unusual along this line.

**OXGART SECRET**

**OXCAR** SECRET 25X1A

This is an extract of taped interview between [REDACTED] and the coordination group pertaining to major aircraft accident S/N 133, 9 July 1964 at Det 1, 1129th SAS, Las Vegas, Nevada.

25X1A

25X1A

[REDACTED]

I was sitting on mobile control waiting for [REDACTED] to come in. The first time I spotted him in the pattern Bill was on high down wind leg. He had a chase with him at the time, Colonel Holbury. Chasing down around to the pattern everything looked normal. In fact I didn't see anything unusual at all about the entire approach until he was rolling out on final. Then the first thing I noticed was that he was kind of flaring. The right wing dipped and it looked like he was having difficulty controlling, as if, fighting the aircraft. I saw fire and pieces of the left nacelle and then the airplane rolled right to the 90 degree point continued to roll on over and hit not completely inverted but almost completely inverted. I'd say it was 15 degrees from completely inverted. I'll go back through this again and try to sequence exactly what I thought had happened. Well, the airplane struck the ground and exploded and the smoke and fire was going up then I saw the chute, Bill's chute. This is really the first good concrete evidence I had that he had gotten out of the airplane because the chute at no time looked like it had fully deployed. I could hardly believe he could make it at that altitude. I estimated this whole thing occurred between 150 and 200 feet, the ejection sequence and the chute and everything else and a ball of fire completely covered the chute. I jumped in the car as fast as I could and drove out through the desert to get to the crash hoping I could get there in time to drag him out of the fire if he was in it or help him out since there was nobody else there. Colonel Perkins and I started out about the same time and I ended up getting there first for some reason. I don't know how. The fire truck was right behind me, one of the big trucks. Well when they got there I saw Bill standing up. He'd already gotten himself out of his chute harness and he was standing there with his face plate up completely covered with dust. I jumped out of the car and ran up to him and asked him if he was alright, of course he was kinda stunned. He mumbled yes and so I started checking him over generally arms, legs and everything else to see if he had any blood on him or anything like this. I pulled him on over and sat him down in the vehicle and started to undress him - get him out of his suit. You know it was pretty hot that day, must of been 85 or 90 degrees at that time of the day. Colonel Perkins drove up then and he helped me undress him.

**OXCAR** SECRET

## OXGART SECRET

We got him out of his suit in 2 or 3 minutes, one of these quick donning types, then we checked him over in his underwear. I could see no injuries at all. Then he started to talk to us a little bit. At that stage of the game I asked him, "what the hell happened". He said, "I just lost control, lost complete control", and he said he did not think he was going to make it. Well, anyway, we put him in the car and Colonel Perkins drove him on into the dispensary. About that time the helicopter arrived. Then several fire trucks came on the scene and the Dr. arrived in the ambulance. That is about the size of it. Now the first day I saw this thing when I came back in operations and made this initial recording, I would have staked my reputation or money on the fact that the left engine without a doubt exploded on him. There is suspicion about it now. I'd still like to have this really looked into. I can't swear that I actually saw him leave the airplane but I did see the fire and explosion in the vicinity of the left nacelle and some pieces leave the aircraft. There was the canopy, canopy shield and two or three pieces blew off. The day of the accident I would have argued with anybody, I was that sure that the engine exploded. However, after thinking about it a little bit more, it just didn't appear that way.

Lt. Colonel Blesse: There were comments of other statements regarding the fact that the approach was excessively steep even for [REDACTED] that sink rate was extremely high and I was wondering what your comments and observations were.

25X1A

25X1A

[REDACTED] Let's just put it this way. The way he was flying that pattern was I thought he was making a single engine approach; high base, high final and descent, pretty good sink rate but also he had the airspeed. At the time we saw him he was flaring and by the time he would have gotten down to the point where he would have been landing, he would have had the sink rate killed. It was a pretty good sink rate coming down. You could notice a fairly high rate of sink, but I didn't consider it a dangerous approach or anything else, in fact I thought it was beautiful, considering the problems he had in flight with the engine. I thought first he was making a precautionary simulated single engine approach all the way around so he could use reduced power. It was excessive as far as a normal type pattern we usually make out here, but Bill normally makes a much higher down wind and much higher base

OXGART SECRET

**OXCAR T S E C R E T**

than most pilots here. He always approaches high like this floating in and he comes down fairly steep on final breaks his flare and comes in and lands it, and in this airplane you can do this. Delta wing is extremely good on recovery, not like a 104 or 100. When you round out it doesn't continue on down.

Colonel Blesse:  
25X1A

Let me ask you this, in an F-100 would it have been excessively steep in your opinion?

Yes sir. He would have never made it. In a 100 this would have been too steep. In this airplane it's quite prominent in fact if you watch single engine approaches out here, you see a lot of them just steep. They always have the airspeed, they'll have 200 plus 200 is minimum airspeed on this type approach and based on his fuel he could be as high as 220-230 at this point.

Colonel Blesse:  
25X1A

We have pretty well sailed down the airspeed to be around 195 to 200. Lets say 200 plus or minus maybe 5 knots.

That would have been plenty airspeed.

Colonel Blesse:  
25X1A

Assuming better than 190 would you say there is any possibility at all that he could have developed a sink rate that he could not break?

No. I just don't feel, not in this airplane with the control you have I feel this has nothing to do with the accident at all. Now if this had been real close to the ground, this fantastic sink rate, then it may have had some bearing on it, the point is I say he was just starting to break his flare. I remember Colonel Perkins mentioning he's really got a sink rate. And he was coming down like this and then he was sort of breaking it and that's when he had his problems. Just as he was breaking his flare. Actually the sink rate stopped drastically right then. He was preparing for landing and then he went right on over and right on in. From the time he rolled it was a matter of seconds that he hit the ground. Something caused the aircraft to go out of control. Just lucked out. I said the other day I would swear the engine exploded and then I would have said that there was burn through prior to this time and he just didn't sense it.

Major Haupt:

I have a question there, Mele, did you see any unusual pitch altitude changes, either adjusting before the rolling maneuver or while it was developing?

**OXCAR T S E C R E T**

**OXCAR SECRET**

25X1A

[REDACTED]

Nothing excessive, Ray, you know the airplane comes down final normal 7 to 9 degrees nose high and this is exactly what he had all the way down. When he started breaking his glide it looked like a perfectly good approach and I was just going to remark, Boy, this was going to be real good for a single engine type approach which I assumed that Bill was making at this time.

Major Haupt:

You already stated that you didn't see any yaw.

25X1A

[REDACTED]

There was no yaw there at all, Ray.

Colonel Blesse:

In your transition program, when you first flew the airplane, were there ever periods with the 2 seater where you had a chance to go up and develop sink rates and break them; in other words to practice landing patterns or thins of that nature, did you do any of that?

25X1A

[REDACTED]

No.

Colonel Blesse:

Have you ever done that with the other airplane?

25X1A

[REDACTED]

Not in the transition program, I would probably say that people have done it on occasions but you have a two or three G limitation. I'd say no, no one has ever tried this.

Colonel Blesse:

We wonder if there isn't a slim possibility the flight envelope has not been explored thoroughly enough. To that extent maybe there is something about the aircraft that might show up in developing a certain sink rate and then trying to break it. It's possible, if you took one up to 20,000 feet got it going at a good sink rate like this, roughly same airspeeds, and then intentionally pulled it back a little bit too tight. The thing might roll on you and if so it would tell us alot.

25X1A

[REDACTED]

I have flown the A-12 probably more than most of the troops around here, and I've had an awful lot of high steep approaches. I've tried them from just about every angle you can imagine, trying to get this thing on the ground, and under no conditions have I ever had trouble breaking that sink rate.

Major Haupt:

It should be noted the 101 was in the general vicinity of the airplane. We don't know how close to flying a perfect formation at the time, with no flaps, but he had gear up with no flaps. With the speed brake extended and basically 200 knots the F-101 is a blivitt. I also point out that he evidently recovered from the sink rate of the A-12 without flaps and only military power. According to the

**OXCAR SECRET**

**OXCAR T S E C R E T**

pilot's statement almost immediately then went into 30 degree bank to keep the crash site in view. This is at military power, he stated that he never again checked his airspeed and by the time he made a turn around the crash site and entered downwind for a landing on 14 he rolled out on downwind at 240 knots. Therefore, one thing we can safely assume is the fact that the 101 definitely was not below 200 to do what Colonel Holbury did in the airplane. If the A-12 was anywhere below 200 he would have had at least a 40 to 50 knot closer rate.

Colonel Blesse: At 200 knots do you feel the A-12 is better than the 101?  
25X1A

[REDACTED]  
Yes sir.

Major Haupt: No comparison, the F-101 is the worst by far of the two airplanes from the standpoint of breaking the sink rate. The A-12 flares beautifully where as the 101 mushes like a son-of-a-gun. I seriously doubt the capability of Colonel Holbury to recover without hitting the ground first if the A-12 had been sinking excessively.

Colonel Blesse: Were you higher? (to Capt Roussell)

Captain Roussell: We're just a little bit higher.

Colonel Blesse: Not much change in your relative position?

Captain Roussell: No, we were closing on him very very slowly all the way around the pattern, we did definitely have 250 knots all the way until the turn on the final with wings level we started slowing down and we never did get under 225 knots.

Colonel Blesse: And never passed him until after the crash?

Captain Roussell: We kept closing on him slowly and we were abreast, directly abreast of the impact of the crash.

This is the end of [REDACTED] testimony. 25X1A

**OXCAR T S E C R E T**

**OX CART SECRET**

This is an extract of taped testimony given to the Operations Group by Sergeant Fout on 15 July 1964 concerning major aircraft accident, s/n 133, at Det 1, 1129th Special Activities Squadron, 9 July 1964

Col Blesse: Is there anything that you would like to add to your statement since reviewing it?

Sgt Fout: No, Sir I can think of none.

Col Blesse: As you observed the aircraft going over your vehicle and to the right of you, did you notice was the airplane in a rather standard rate of descent? Did it appear to be standard all the time? Was it standard for a while, then increase or how did you see it?

Sgt Fout: It appeared to be just a normal descent til after it got roughly 2 or 3 thousand feet ahead of us and then it started dropping lower. I have watched several of the descents and noted different types and thought nothing of it, thought nothing of its low altitude until I saw the aircraft tilt to the left. At this time, all I saw was the aircraft and 3 different parts flying away from it. I assumed it to be the canopy and seat and knew it was the seat when I saw the pilot getting up off the ground on the left side.

Col Blesse: Could you tell what altitude the a/c was in when the seat fired? Do you remember that?

Sgt Fout: The a/c was in a bank (showing about 40 to 45° with hand).

Col Blesse: How about the canopy?

Sgt Fout: The canopy seemed to go quite a bit before. It shot more straight up.

25X1A

██████████: Could you give us an estimate of how far over it was when the canopy went?

Sgt Fout: Practically level.

Col Blesse: Did you see the chute in the air at all?

25X1A Sgt Fout: No, Sir.

██████████: What would you say the attitude of the airplane was when it hit?

Sgt Fout: More vertically or 90° of bank.

25X1A

██████████: Not inverted?

Sgt Fout: No, Sir.

**OX CART SECRET**



25X1A

**OX CART    S E C R E T**

██████████ Did you notice it to bounce when it hit?

Sgt Fout:     No, Sir. It hit and exploded.

Capt Roussell: Did you notice the right wing dip before the a/c started rolling left?

Sgt Fout:     None to speak of.

Capt Roussell: Was the rate of roll increasing or constant?

Sgt Fout:     Constant.

Maj Haupt:    Did you see the afterburners fire?

Sgt Fout:     No Sir, none whatsoever.

Capt Roussell: Did you notice anything looking peculiar about the elevons or rudder?

Sgt Fout:     No Sir. Everything just seemed normal.

25X1A

██████████ You say you were pretty close, do you think you could have noticed deflected ailerons?

Sgt Fout:     Yes Sir, I think so.

Capt Roussell: Do you remember how far this side of the low freq site you were when you first saw the airplane appear in your windshield?

Sgt Fout:     I would say a half mile.

**OX CART    S E C R E T**

# OXCART SECRET

This is an extract of taped testimony given to the Operations Group by Sgt Law on 15 July 1964 concerning major aircraft accident, S/N 133, at Det 1, 1129th Special Activities Squadron, 9 July 1964.

Col Blesse: Any changes or additions you would like to make to your statement since rereading it?

Sgt. Law: No, Sir. There appears to be a typographical error in the statement that the Colonel departed with the suit because the suit was in another car. This, I know, has no bearing on the accident so I will leave it as it is. I know nothing that I could add.

Col Blesse: As the aircraft went over your head and continued on out in front of you, it would have been slightly to your right wouldn't it?

Sgt. Law: Yes, Sir.

Col Blesse: Did you note any sudden change in altitude or did the altitude both continue normal or fairly consistent as it had been according to you?

Sgt Law: It seemed as I looked out the right window of the truck. It completed the turn just to the right of us then continued straight on and it didn't make any sharp change, but he did lose altitude quite rapidly as it did appear to me. At the time he was dropping quite rapidly for his distance away from the runway

25X1A

[REDACTED]

How close you think he was to the ground when the aircraft went into the roll, because I note you said 200 feet, do you think this to be accurate or you are just guessing?

Sgt. Law:

25X1A

[REDACTED]

That might I am just guessing because distances and heights are quite deceptive here in the desert.

The aircraft has a length of approximately 100 feet. Give you an idea, now what would you say?

Sgt Law:

I would say more like 200 feet now.

25X1A

[REDACTED]

What attitude you feel the aircraft was in when it hit the ground?

# OXCART SECRET

**OXCAR. SECRET**

Sgt Law: The left wing was all the way over and coming back up. The nose appeared to strike first. It looked like if he would have had another 50 or 100 feet of altitude the aircraft would have completed the roll and landed right side up.

Capt Roussell: How far this side of the low frequency site were you when you first observed the airplane?

Sgt Law: Just pass the perpendicular road which is, I believe, a mile or a mile and a half from the beacon site.

Capt Roussell: You state that a 45° of bank, a piece of the aircraft flew off. Do you feel that this was the canopy?

Sgt Law: Yes, Sir.

Capt Roussell: Did you see the pilot seat come out?

Sgt Law: No, Sir, we did not particularly notice the seat coming out at all.

Capt Roussell: When was the first time you saw the chute?

Sgt Law: We didn't see the chute until after the crash.

Capt Roussell: You saw the chute blossom about the same time as the airplane hit the ground.

Sgt Law: Yes, Sir. I was looking at the crash to the right of the road. I also noticed the chute blossom to out left. We didn't think it to be the pilot's chute because it appeared so small. It was a matter of just a few seconds before the chute hit the ground.

Maj Haupt: Could you tell whether the chute was fully or partially open?

Sgt Law: No, Sir.

**OXCAR. SECRET**

**OXCART**

S T A T E M E N T

9 July 1964

25X1A

1. I, [REDACTED], having been first advised that the purpose of this investigation is not to obtain evidence for the use in disciplinary action, or for determining pecuniary liability or line-of-duty status, or to revoke commission or remove from the active list under the provision of AFR 36-2, or for use before a Flying Evaluation Board, but rather is to determine all factors relating to the accident/incident, and, in the interest of accident prevention, to avert recurrence, do hereby make the following voluntary statement.

25X1A

2. [REDACTED] Pilot, Aircraft Number 133.

3. I trimmed both engines at the end of the runway for 808°. The right engine went to 845° during the climbout. I had to trim it down. The left one was quite low during the climb. However, during the acceleration it came up and at 40° I had to trim them both down a bit.

I continued to accelerate to 2.8 Mn at which point I started climbing slightly to maintain 2.8. I turned around just short of the Canadian border and headed south. At 328 KEAS I tried to close the onion slicer down slightly on the left side. Shock popped. I waited for the shock expulsion sensor to recapture the shock, which it did. I then tried re-lighting the afterburner several times and it would relight but I didn't seem to be getting any power out of that side. I noticed that the compressor inlet pressure of the left side was way down. I tried closing the onion slicer and working with the bypass doors. This did not correct the situation. I was finally able to correct the situation by going forward on the spike and back to auto and I could feel the spike retract and capture the shock. The duct pressure went back up to normal on the left side and I continued to come south but I noticed that the left EGT was 850 since I had trimmed it up while the duct pressure was low. I immediately trimmed down on the left side and accelerated back up to 2.8 and headed directly home.

I cruised back down south at 2.8 with no difficulty. I made a large turn around the airport and decelerated down to traffic pattern speed. The right windshield frosted up as I was descending. I entered the downwind, turned onto base with the gear down, turned on the final approach holding around 200 IAS. I started slowing down for the final approach straightaway on the final approach. I was straightaway on the final approach with the power back and I started going into a left roll. I fed right aft elevon in and I was able to control the bank for a short period of time and then it started on over with full right aft elevon in. I advanced the power and it didn't look like I could go around either and I was still going over to the left and I ejected. I turned over and over

**OXCART SECRET**

Statement, [REDACTED] (continued)

several times. The chute jerked open and I felt intense heat on my face. I looked over and the airplane was burning under me and I hit the ground just at that time. The chute was dragging me over into the fire so I grabbed the riser and pulled it down and got out of the parachute.

Comments:

1. I lost yaw "A" when I popped the left shock way up north.
2. I overtemped the left engine to 850 for some unknown period of time at 2.75 Mn.
3. I have no idea what happened on final approach except that sitting here now it is very possible that the left engine quit and I was unable to detect this. I had practically no time at all to look around the cockpit before ejection.

Supplement to [REDACTED] Statement: 25X1A

In reading over my statement that was made immediately after the accident, I feel that the aircraft never stopped rolling once it started. I do not believe that I ever had any effect on the roll rate.

4. The above statement is true to the best of my knowledge and belief.

WITNESS: Richard J. Russell

25X1A

SIGNATURE

*for*



OXCART

SECRET

**OX CART** **SECRET**

## S T A T E M E N T

9 July 1964

1. I, Roland L. Perkins, Lt Col, 40170A, Det 1, 1129th USAF Special Activities Squadron, Las Vegas, Nevada, having first been advised that the purpose of this investigation is not to obtain evidence for use in disciplinary action, or for determining pecuniary liability or line-of-duty status, or to revoke commission or remove from the active list under the provisions of AFR 36-2, or for use before a Flying Evaluation Board, but rather is to determine all factors relating to the accident/incident, and, in the interest of accident prevention, to avert recurrence, do hereby make the following voluntary statement.

2. Identify and qualify witness: Age 46; Duties, Assistant DCO; Experience, Command Pilot, not qualified, Flying Status Code 1A; Location at time of accident, at mobile control observation position which is approximately 1000' down runway 32 on West side of runway.

3. The first report I had on the aircraft was that he was approximately 300 miles north with left engine shutdown. This information was received on secondary crash alarm from Boxer control, the Area Command Post. I went out in my car to the mobile control point and on hearing no information, called Boxer control and asked that they relay to the hangar that a tow bar be available to tow the aircraft off the runway if the left engine was not relighted for landing. I was advised that the engine was running and that the pilot had no air control. The emergency was kept in. The next transmission I heard was the chase aircraft, Boxer 14, talking with Dutch 33. Dutch 33 reported 1000' high, approximately 70 miles west of Mackerel. No tunnel clearances required. The next transmission was an attempt by Boxer 14, relayed to WARTH to Dutch 33. The pilot of 133 reported approximately 7000' alt decelerating in a big left turn. The next contact was on 121.1, tower control. Dutch 33 reported over Baldy, requested landing instructions, received and acknowledged. The tower advised Dutch 33 that tower had information he had no yaw control and crash equipment was standing by. The pilot reported "A" yaw system inoperative and acknowledged the crash facilities. The next observation of the aircraft was turning from downwind to base on a typical pattern flown by this pilot. Everything appeared normal at the time. It was a high downwind with a high right turn to base, continued by descending turn and everything again appeared normal. Turn to final was approximately his usual height. At this time the aircraft appeared to begin sinking in a nose high attitude. I spoke to the mobile control officer, [REDACTED] and said, "Look at the excessive sink rate". About this time the nose began rising and the aircraft appeared to make a completely coordinated left roll. At an estimated 100-200' altitude I saw the pilot eject; the aircraft continued rolling, nose dropped immediately and made impact with the ground. The billowing smoke prevented my seeing the chute bloom. I went immediately to the crash scene upon hearing Boxer 14 report the pilot was approximately 100' to the left of the aircraft. My car became stuck and I was 3rd at the scene, following mobile control,

25X1A

**OX CART** **SECRET**

Statement by Lt Col Perkins (Continued)

*RP*  
Mr. Vojvodich, and one of the crash vehicles. We desuited the pilot. We queried him as to his condition. He reported that he hated to leave the aircraft but he had no idea what happened. He just knew that he had to leave. We stopped by the ambulance. The technician corpsman asked if there was anything wrong. The pilot reported very slight soreness in his left shoulder and stated that he wanted to go over to debriefing and get it on tape immediately while it was fresh in his mind. The pilot was taken to Hangar area and reported to the Flight Test Engineer office. His location was reported to Boxer control for relay to Personal Equipment and the Flight Surgeon's office. This completes my eyewitness account to the best of my knowledge.

4. The above statement is true to the best of my knowledge and belief.

WITNESS

*Richard J. [Signature]*  
SIGNATURE

*Richard L. Perkins*  
12 July 1964

This is supplementary statement to my previous account previously given.

I would also like to state that my remembrance or additional information was not after having talked with other personnel who made this same observation.

When the aircraft was on final and, as previously stated, the nose began to rise, as the aircraft started a left roll I remember at some time at this point and prior to having seen the pilot eject, there appeared to be an explosion on the left side of the aircraft in the left wing area. This was sometime prior to the aircraft reaching a 90° roll point. The aircraft appeared to be burning or on fire with smoke billowing prior to impact. This completes supplementary information.

WITNESS

*Richard J. [Signature]*  
SIGNATURE

**OX CART**

**SECRET**

**OXGART SECRET**

Approved For Release 2001/08/29 : CIA-RDP71B00590R000100040001-1

S T A T E M E N T

16 July 1964

1. I, Roland L. Perkins, Lt Col, 40170A, Det 1, 1129th USAF Special Activities Squadron, Las Vegas, Nevada, having first been advised that the purpose of this investigation is not to obtain evidence for use in disciplinary action, or for determining pecuniary liability for line-of-duty status, or to revoke commission or remove from the active list under the provisions of AFR 36-2, or for use before a Flying Evaluation Board, but rather is to determine all factors relating to the accident/incident, and, in the interest of accident prevention, to avert recurrence, do hereby make the following voluntary statement.

2. Identify and qualify witness: Age 46; Duties, Assistant DCO; Experience, Command Pilot, Jet qualified, Flying Status Code 1A; Location at time of accident, at mobile control observation position which is approximately 1000' down runway 32 on west side of runway.

3. Having been asked to clarify statement about the sink rate of the A-12 on final approach the following additional statement is made by Roland L. Perkins, Lt Col, 40170A. The aircraft flew a high base leg which is typical of this pilot. Turn to final was normal and the aircraft then assumed the normal final approach attitude flown by this pilot. Everything appeared normal during the approach. Shortly after the aircraft had rolled out on final and established a normal slightly nose high attitude, I observed the aircraft to be in an obviously abnormal sink rate with the attitude of the aircraft not at that time having been changed. It was during this sink that I mentioned to the Mobile Control Officer, Mr Vojvodich, to "look at that sink rate". It then appeared as though the pilot had recognized some problem being encountered and had applied power as it seemed the aircraft was having power applied. The nose rose to an estimated maximum deck angle of approximately 10 degrees, or rather the tail just seemed to settle and the nose raised by rotation of the aircraft on the aircraft axis and simultaneous roll to the left was begun. Until the high sink rate on final was first noted, the final approach appeared to be completely normal and, at the altitude of the aircraft prior to the excessive sink rate developing, I believe the aircraft could have lost power on both engines and have made the hard surface of the runway successfully. This does not intend to construe that the aircraft could actually make a double flame-out landing since hydraulic pressure demands prevent such a landing; the statement is merely to attempt to more definitively describe a successful pattern having been established and flown up to the point of first developing an unusual and high sink rate from a normal final approach, followed immediately by nose rising with simultaneous roll to the left.

4. The above statement is true to the best of my knowledge and belief.

WITNESS

Richard J. [Signature]

SIGNATURE

Roland L. Perkins

**OXGART SECRET**

Approved For Release 2001/08/29 : CIA-RDP71B00590R000100040001-1



~~SECRET~~

## STATEMENT

25X1A

9 July 1964

1. I, [REDACTED], (Civ), Det 1, 112<sup>nd</sup> USAF Special Activities Squadron, Las Vegas, Nevada, having first been advised that the purpose of this investigation is not to obtain evidence for use in disciplinary action, or for determining pecuniary liability or line-of-duty status, or to revoke commission or remove from the active list under the provisions of AFR 36-2, or for use before a Flying Evaluation Board, but rather is to determine all factors relating to the accident/incident, and, in the interest of accident prevention, to avert recurrence, do hereby make the following voluntary statement.
2. Identify and qualify witness: Age 35, Pilot, A-12 Aircraft, location at time of accident was 1000' from touchdown point on the runway.
3. I was the Mobile Control Officer situated about 1000' from the touchdown point on the runway and I observed Dutch 33 and Boxer 14 on a high downwind and high speed low landing runway 32. The approach looked normal all around downwind and on base. It was a little steeper than normal approach. It's about the way that most of us would fly a single engine approach. He rolled out on final straight and level and I didn't notice anything unusual at all. He did have above average rate of sink on final approach but when he started his flare about 300-250' out I observed the jigging of the wings. The right wing dipped and the left wing dipped and then he started a slow roll to the left. At about this time I saw the seat go. I would estimate that he was in 900 bank when the seat ejected. Also, just at the time he got about 900 I thought I observed an explosion in the left engine. It was just a brief flash fire. I didn't see the wing buckle although it very well may have at that time. The airplane continued to roll over completely inverted and hit the ground nose first completely inverted and then completely exploded. I saw the chute blossom and I just saw the chute open and it was completely obliterated by the flame and smoke and I estimate the chute opened when he was about 100' in the air at the very most. In fact, I didn't think it completely blossomed when the pilot hit the ground but it obviously did. The fire and the smoke covered the pilot and I raced out over the overrun and I was the first one on the scene. When I got there Bill was just getting up, had just unbuckled himself from the seat and was standing there kind of in a daze. Of course I shook his hand and congratulated him on getting out. I thought he'd bought the farm. I'm sure he did too. I asked him what happened and he told me that he just lost control. Of course he was still dazed and it was obvious that he lost control of the aircraft 'cause it just rolled over on him inverted. The flash fire that I observed, or the explosion, just at impact was very low when it occurred and it was something that happened. There was a flash fire on the left engine and kind of an explosion and it looked like a few pieces of titanium may have come off the nacelle and an instant later the whole aircraft hit the ground. That whole left wing could have been about to fold or folded because

~~SECRET~~~~SECRET~~

25X1A

**OX CART** **SECRET**

Statement by Mr. Vojvodich (Continued)

it was real hard to tell at that angle. It appeared to me that he had lost complete control of the aircraft. I don't think it was the loss of an engine that caused it as such because there was absolutely no yaw involved in the maneuver at all and he was just coming down straight and final approach. It was just a wiggle and then a roll over and it wasn't a fast one, even. It was slow enough you could recognize he was going out of control like that. When I got to Bill I checked him over right away to see if he had any broken arms or legs and I couldn't see any and he was standing there talking to me. I sat him down in the staff car and started unbuckling his suit and about that time a fire truck drove up and then shortly thereafter the ambulance arrived and we soon got him out of his suit and I think they took him up to the dispensary or someplace. This is about the size of what I saw out there.

4. The above statement is true to the best of my knowledge and belief.

WITNESS

*Andrew C. Bless*

25X1A

SIGNATURE

[REDACTED]

**OX CART**

**SECRET**

**OXGART SECRET**S T A T E M E N T

9 July 1964

1. I, Robert J. Holbury, Colonel, 9893A, Det 1, 1129th Sp Acty Sq, P. O. Box 882, Las Vegas, Nevada, having been first advised that the purpose of this investigation is not to obtain evidence for use in disciplinary action, or for determining pecuniary liability or line-of-duty status, or to revoke commission or remove from the active list under the provision of AFR 36-2, or for use before a Flying Board, but rather is to determine all factors relating to the accident/incident, and, in the interest of accident prevention, to avert recurrence, do hereby make the following voluntary statement.

2. I am 44 years of age. Present duty is Commander of Det 1, 1129th Sp Acty Sq, P. O. Box 882, Las Vegas, Nevada with 22 years military service. I was flying chase for Dutch 33 on 9 July 1964 and was approximately 300 feet from him at his 7 o'clock position when the accident started.

25X1A

3. [REDACTED] and I were briefed together by Captain Roussell in Base Operations at 0700, 9 July for this flight. Captain Roussell joined me in F-101 chase aircraft Nbr 312 (Boxer 14). Dutch 33 made normal engine runup in place at end of runway, he was cleared for unrestricted climb and I called AB lites. I closed with Dutch 33 at about 24,000 feet on climb out and looked him over. He was clean and I so advised. I descended under the tunnel to conserve fuel. Dutch 33 continued climb and I lost sight of him until he started to con. At Dutch 33's request we changed to button 6 and checked in with each other and Bungalow. Bungalow advised he had a good pain in the aircraft. I stoozed around in the SOA at 34,000 feet awaiting Dutch 33's return. I heard Bungalow acknowledge Dutch 33's north turn but did not hear Dutch 33's transmission. Shortly thereafter I heard Bungalow talking to Dutch 33. The gist was Dutch 33 had lost his engine but had it restarted. His "A" yaw was out. He was continuing on home plate at speed and altitude. He was approximately 300 miles north-northwest of Bungalow at this time. I started to pace myself to home station to intercept Dutch 33 on his descent if possible. Clearance through the tunnel at 34,000 was obtained from Bud. In response to my query Dutch 33 advised he was over Tonapah and would decelerate in big left turn around home plate. I next spotted him east of home plate as he started to con during his descent. He was still high. He confirmed his position. I lost him when he ceased conning. Next visual was when he was west of home plate, in left turn descending toward Baldy. I maintained visual contact throughout the rest of the flight. In response to query from Bud Dutch 33 advised all was OK except for "A" yaw and no problems. I joined up on Dutch 33 as he was making high right turn onto downwind. His gear was down and appeared locked. Altitude about 28,000 feet and speed at 300 KIAS. A high rate of descent was maintained throughout downwind. Configuration of F-101 to maintain relative position was gear up, flaps up, boards

**OXGART SECRET**

**OXGART SECRET**

Statement, Robert J. Holbury, continued.

out, power about 82 to 84 percent, speed 300 KIAS. I folded boards for a few seconds and closed on Dutch 33. Boards out on attaining desired position. I glanced at airspeed and altimeter on turn to base. Speed was between 250 to 260 and altimeter going through 12,000. My position was about 1,000 feet from Dutch 33 at about his seven o'clock and maybe 500 feet above him. I closed slowly as we proceeded down base. Dutch 33 called base and gear down. Just immediately before turn onto final Bud cleared Dutch 33 to land and advised check gear and limiter. Dutch 33 answered Roger and immediately started turn of about 30 degree bank onto final. I did not notice my altitude - distance to ground appeared normal as I flew loose formation with Dutch. My speed was just slightly above 250 KIAS. My configuration was clean except for boards. Pitch and horn limiter switches on. Power not noticed but above 85 percent I'd guess. I'm about 500 feet from Dutch 33 at his seven o'clock position. I was closing slowly. Dutch 33 rolled out onto final and appeared to be lined up. I crossed almost directly over milk pail. Dutch 33 was proceeding down final for some time with everything appearing perfectly normal. At about 400 to 500 feet above ground (estimated) I glanced into my cockpit to check fuel and airspeed - particularly airspeed in that I did not have flaps down. Fuel was just below 3000, airspeed just slightly above 230 KIAS. The alpha W needle of the PBI was at about 10 with horn and pusher boundary needles at about 12. At this point Captain Roussell said, My God, look at the aircraft. I immediately looked at Dutch 33 who was about 300 feet from me. His nose was slightly high and he was rolling to the left at a fairly rapid but steady rate. I would estimate he was about 15 to 20 degrees left wing down at this time. As aircraft was between 45 to 90 degrees I observed pilot ejecting but lost him for a moment as aircraft continued apparently steady roll rate with nose dropping rapidly when passing 90 degree point. It impacted nose down, upside down after completing what I'd estimate to be 180 to 195 degree of roll. I was certain the pilot hadn't cleared the crash. At about the second of impact I observed the chute streaming (about 3/4 full) for a split second and then it blossomed full and pilot contacted ground immediately. I did not see him move and was again afraid he'd not made it. I observed the chute billowing toward the fire which was only about 100 to 150 feet away and was concerned lest the pilot be dragged into the fire area. I called Bud and advised of pilot's position and requested expedite pick up due fear of pilot being dragged into fire. I did not receive a reply. It wasn't until later that I realized my receiver had failed. I circled to right as tightly as possible and when I could next see parachute it was lying on the ground. I did not see any movement nor could I see the pilot. A station wagon with a white top was approaching the pilot. The fire was almost out. I could not hear any radio talk. I landed immediately. The greatest sight was to observe Maj. Burk with Lt Col Perkins enroute to base area as I taxied to parking area. I would estimate Dutch 33's speed at

**OXGART SECRET**

**OXCAR**

Statement, Robert J. Holbury, continued.

time of roll to be 200 plus or minus 10 KIAS.

4. The above statement is true to the best of my knowledge and belief.

WITNESS:

*Richard J. [Signature]*

SIGNATURE:

*Robert J. Holbury*

**OXCAR**

~~OXGART~~ ~~SECRET~~  
S T A T E M E N T

9 July 1964

1. I, Richard J. Roussell, Captain, 45805A, Det 1, 1129th Sp Acty Sq, P. O. Box 882, Las Vegas, Nevada, having been first advised that the purpose of this investigation is not to obtain evidence for use in disciplinary action, or for determining pecuniary liability or line-of-duty status, or to revoke commission or remove from the active list under the provision of AFR 36-2, or for use before a Flying Evaluation Board, but rather is to determine all factors relating to the accident/incident, and, in the interest of accident prevention, to avert recurrence, do hereby make the following voluntary statement.
2. I am 33 years old. I am the Base Operations and Flying Safety Officer for the Detachment. I am presently checked out and current in the T-33 and F-101 aircraft. I was flying in the back seat of "Boxer 14", chase aircraft for Dutch 33 at the time of the accident.
3. I was designated to be the operational briefing officer for Dutch 33 scheduled for 0700, 9 July 1964. The pilot came in for briefing and it consisted of briefly mentioning the route to be flown, emergency bases along the route and status of enroute bases. (NOTAMS) I mentioned additional traffic that could be encountered in the SOA during the flight, the status of Nellis gunnery ranges, the status of AEC activity of which there was none. The Airfield hazards, including construction of the airdrome were discussed and understood by the pilot. The NAVAIDS at the facility to include that of the Northern AFCS site were "IN" at the time of briefing. The pilot acknowledged complete understanding of the entire briefing and immediately departed for the weather station to receive the weather for the route to be flown. I was invited by the chase pilot to join him and I did. We took off and formed up with Dutch 33 immediately after take off and advised that he looked clean and he acknowledged. We proceeded into the SOA and orbited an area just North of the tunnel awaiting Dutch 33's return. We lost radio contact with Dutch 33 but overheard our Northern AFCS mention that the pilot was having difficulty. We immediately asked for tunnel clearance to return to homestation at altitude thus giving us an advantage to pick up and reform on Dutch 33. We picked up the aircraft in a large left turn while in the contrail level and started to reform over Bald Mountain at an altitude of 28,000 to 30,000 feet as he was descending at a very fast rate, gear down, for entry to downwind for landing Runway 32. We joined Dutch 33's left side closing slowly. We were at an altitude of 15,000 to 16,000 on a wide downwind and approximately 12,000 on a wide base leg with an air-speed of 250 to 260 knots. Dutch 33 continued the descending turn to final at which time he rolled wings level. Everything appeared to be normal to this point. On final, I noticed that we were maintaining approximately 230 to 240 knots still closing very slowly. Just prior to the accident, I observed the aircraft in a gentle left bank continuing over. Just prior to reaching or what I would estimate a 90° bank, I observed the seat ejecting and immediately afterwards the chute blossomed. I

~~OXGART~~ ~~SECRET~~

Statement by Captain Richard J. Roussell, continued.

would estimate that at that time, we were 300 to 350 feet aft and approximately 125 to 150 feet left of Dutch 33. The Aircraft continued to roll and made contact with the ground almost completely inverted. My concern then was focused on the pilot and I had observed his chute to the left of the impact point approximately 125 to 150 yards, (just west of an access road that is used to and from the low frequency transmitter site). We could not tell the pilot's condition at the time so we made every attempt to direct help to him via UHF radio. We observed a staff car going to the pilot and we lost our radio receiver about the same time. We set up a pattern for landing Runway 14 which worked out fine. We did not know the condition of the pilot until we saw him come by sitting in the right seat of a staff car. We received an OK signal from the driver.

4. The above statement is true to the best of my knowledge and belief.

WITNESS:

*Hubert A. Brown*

SIGNATURE

*Richard J. Roussell*

**OXCAR1 SECRET**

OXGART

9 July 1964

1. I, Paul S. Fout, SMSgt, AFM 1077, Det 11, 1800 Spt Sq, having first been advised that the purpose of this investigation is not to obtain evidence for use in disciplinary action, or for determining pecuniary liability or line-of-duty status, or to revoke commission or remove from the active list under the provision of AFR 36-2, or for use before a Flying Evaluation Board, but rather is to determine all factors relating to the accident, and, in the interest of accident prevention, to avert recurrence, do hereby make the following voluntary statement.

2. Age 31, Dutics-Communication Electronics Superintendent, Experience- In Radio and Nav-Aid Career Field since 1951, Exact location at time of accident- Returning from Radio Leacon.

3. At approximately 0930L, 9 July 1964, I with one passenger TSgt Thomas A. Law, was driving north parallel road and was to approach to runway 32 in a sand track. A few minutes earlier I had departed the Radio Leacon, Building 152, enroute to the main compound. To my right was a Dutch aircraft making an approach to runway 32. After the aircraft had passed and was about four thousand feet ahead of me, it appeared to be very low, approximately 100-150 feet high, when an object flew up from the aircraft. An instant later the aircraft tilted to its left side as another object flew out from the aircraft which I later learned seconds later was the pilot being ejected. Also, at the same instant, the aircraft appeared to hit the ground, nose and left wing first, exploding into flames. Realizing what had happened and seeing the pilot walking toward the road from the left side, I accelerated the vehicle to offer assistance. At this same time a station wagon approached the pilot from the opposite direction. It reached the pilot a few seconds ahead of me, and the driver, with the aid of the pilot, had just begun the removal of the pilots flight suit. Sgt Law and I jumped from our vehicle and assisted in removing the suit. While doing so another vehicle approached from the north with one man whom I recognized as Col Perkins. He stopped, opened the right door of his station wagon, and the pilot sat on the seat while we finished removing the flight suit. I then took the suit and placed it in the back seat of the vehicle which had arrived first while Col Perkins turned his vehicle around and drove north with the pilot toward the main compound. The driver of the other vehicle, Sgt Law and I walked about 20 feet west of the road to where the parachute and pack were laying with intentions of placing it in the station wagon when the driver of the station wagon said that it may be best to leave it as it lay. Sgt Law and I returned to and mounted our vehicle as a man with a blue security badge and three men with blue and red security badges appeared on my side of the vehicle. I told them who I was, organization and business in that area. At the same time Sgt Law was giving our names and telephone number to a MSgt

OXGART

SECRET



**OXGART**

**SECRET**

from the Fire Department who had approached the right side of the vehicle. I then left the scene and drove north to the compound.

4. The above statement is true to the best of my knowledge and belief.

WITNESS

Richard J. Russell

SIGNATURE

Paul S. Fout

**OXGART**

**SECRET**

OXGART

9 July 1964

1. I, Thomas E. Law, TSgt, AF12352957, Det 11, 1800 Spt Sq, having first been advised that the purpose of this investigation is not to obtain evidence for use in disciplinary action, or for determining pecuniary liability or line-of-duty status, or to revoke commission or remove from the active list under the provision of AFM 36-2, or for use before a Flying Evaluation Board, but rather is to determine all factors relating to the accident, and, in the interest of accident prevention, to avert recurrence, do hereby make the following voluntary statement.

2. Age 35, Duties-Navigational Aid Technician, Experience-In Radio and Nav-Aid Career Field Since 1950, Exact Location at time of accident-Returning from Radio Beacon.

3. The morning of 9 Jul 64 at approximately 0930L SMSgt Paul S. Fout and I were returning from the home beacon site at the south end of the area. Sgt Fout was driving proceeding north on the road that runs adjacent and parallel to the extended runway centerline. We were traveling fairly slow and approximately half way to the perimeter road when I looked out the right window and up and saw a Dutch aircraft turning on to final. When he completed the turn and leveled he was then visible through the windshield of the truck. Shortly after leveling he began losing altitude quite rapidly but at a level attitude. When 100 to 200 feet above ground the aircraft started into a slow roll to the left. At 45 degrees a piece of the aircraft flew off and a sharp flame observed from underneath the aircraft. The roll continued and the aircraft crashed inverted left wing slightly high. At about the time of the crash a parachute was seen to the left of the aircraft and at about the same altitude as the aircraft when it started its roll. It was not immediately apparent that this was the pilot because of size, altitude and other factors. Sgt Fout did not increase speed till a while later when the possibility of it being the pilot occurred to us. The pilot had extracted himself from the chute and seat and was in the road by a station wagon that had just arrived also. We and the driver of the car were helping the pilot out of his flight suit when Col Perkins arrived. After removing the suit he and the Col departed. All emergency vehicles had arrived with security and hanger personnel so we continued on to the base.

4. The above statement is true to the best of my knowledge and belief.

WITNESS

*Richard J. ...*

SIGNATURE

*Thomas E. Law*

OXGART

SECRET

**OXCART**      **SECRET**

STATEMENT

9 July 1964

1. I, Jerry Hall, having first been advised that the purpose of this investigation is not to obtain evidence for use in disciplinary action or for determining pecuniary liability or line-of-duty status, or to revoke commission or remove from the active list under the provision of AFR 36-2, or for use before a Flying Evaluation Board, but rather is to determine all factors relating to the accident, and, in the interest of accident prevention, to avert recurrence, do hereby make the following voluntary statement.

2. I was at the South Pad on Guard Post when I received a radio call that a Dutch aircraft was on final. I turned around to watch it and noticed that it started to tip over on its left side. The plane was at an angle to the left when the engine on that left side seemed to blow up. There was a flash of light and at the time I saw what I thought to be the tail section shoot up into the air, but later found this to be the pilot ejecting out of the aircraft. The plane continued to roll over on its back and then the nose hit the ground first and then the wing and then the middle of the plane hit and bounced into midair and then there was an explosion and it blew apart and disappeared into a cloud of smoke and a ball of fire. I then reported the crash to Delta (Security Office), about 4 minutes later bits of debris and pieces of the aircraft fell all around me at the South Pad.

3. The above statement is true to the best of my knowledge and belief.

WITNESS

Richard J. Lawrence

SIGNATURE

Jerry R Hall

**OXCART**      **SECRET**

**OX CART** **SECRET**

STATEMENT

9 July 1964

1. I, David Kindell, Security Agent, 1129th USAF Sp Acty Sq, P.O. Box 882, Las Vegas, Nevada, having first been advised that the purpose of this investigation is not to obtain evidence for use in disciplinary action, or for determining pecuniary liability or line-of-duty status, or to revoke commission or remove from the active list under the provision of AFR 36-2, or for use before a Flying Evaluation Board, but rather is to determine all factors relating to the accident/incident, and, in the interest of accident prevention, to avert recurrence, do hereby make the following voluntary statement.
2. Security Guard.  $\frac{1}{2}$  mile northwest of runway approach and approximately 1 mile from area of crash.
3. At approximately 0900 hours 9 July 1964 while stationed on LIMA Post by the south hangars, I heard on the radio that Dutch 133 was on emergency. About 0928 I observed Dutch 133 making his final turn on his approach to the runway. While watching through binoculars I observed his left wing dip slightly and then straighten out. Then Dutch's left wing dipped to about a 45 degree angle and I observed fire shoot out of the side of his right engine. After that she flipped over on its back and went in.
4. The above statement is true to the best of my knowledge and belief.

WITNESS

*Richard J. [Signature]*

SIGNATURE

*David Kindell*

DAVID KINDELL

**OX CART** **SECRET**

**OXCART**      **SECRET**

STATEMENT

9 July 1964

1. I, Page Sharp Jr, Captain, USAF, Det 1, 1129 USAF Special Activities Squadron, having first been advised that the purpose of this investigation is not to obtain evidence for disciplinary action, or for determining pecuniary liability or line-status, or to revoke commission or remove from the active list under the provision of AFR 36-2, or for use before a Flying Evaluation Board, but rather is to determine all factors relating to the accident, and, in the interest of accident prevention, to avert recurrence, do hereby make the following voluntary statement.
2. Age: 35, Duty: Flight Surgeon, Experience: 7 years - Flight Surgeon.
3. I was in ambulance #1, and with Run Up pad having responded to a crash call on the aircraft. Aircraft came over field, I heard pilot state on channel #2 he was A.O.K. except a yaw system was out. The aircraft entered the pattern. As it turned on final I remarked that it appeared rather high, and descending rather rapidly (I have seen similar patterns however). The aircraft lined up on final and all seemed well. Suddenly the left wing began to drop. The aircraft turned slightly left, rate of descent appeared unchanged. Suddenly there was a small flash of red-orange light in or very near left engine, probably in aft section near the wing. The left wing continued to fall, a large cloud of debris and smoke appeared obscuring the left engine. The aircraft went out of control and crashed in with a flash and a very large cloud of black smoke. I did not see the pilot eject. The flash I saw might have been the seat firing, however the flare was not located in any reasonable relation to the cockpit area which was viewable. I assumed that the pilot had not escaped the aircraft.
4. The above statement is true to the best of my knowledge and belief.

WITNESS

Richard J. [Signature]

SIGNATURE

Page Sharp Jr.

**OXCART**      **SECRET**

**OXGART SECRET**

STATEMENT

9 July 1964

1. I, Billie R. Holmes, TSgt, AF19477047, Detachment 1, 1129th USAF Special Activities Squadron, having first been advised that the purpose of this investigation is not to obtain evidence for use in disciplinary action, or for determining pecuniary liability for line-of-duty status, or to revoke commission or remove from the active list under provision of AFR 36-2, or for use before a Flying Evaluation Board, but rather is to determine all factors relating to the accident, and in the interest of accident prevention, to avert recurrence, do hereby make the following voluntary statement.

2. Age: 29      Duty: Aero Medical Technician      Experience: 9 years - Medic.

3. On Thursday, 9 July 1964, ambulance #1 responded to a crash call on aircraft #133 when he was reported approximately 350 miles from home plate. We took up stand by position at the north pad and monitored the radio as to the aircraft's position and troubles. The initial report was that he had the left engine shut down, but it was learned from the radio system (Channel 6) that he had made a restart and was experiencing some yaw trouble. We continued to monitor the radio and I made visual contact with the aircraft as he came over Mt. Baldy. Having observed this pilot flying this type of aircraft on numerous different flights, I noted nothing unusual in his approach to runway #32, until he was lined up and making his final approach. At this time I observed what seemed to be a fast sink rate and the aircraft seemed to start to roll off to the left. I next noticed a puff of black smoke and then a flash of orange flame and the aircraft continued the left roll and about 75 to 90 degree left bank. The left engine compartment seemed to come apart and the aircraft continued to roll to the left and hit in an upside down attitude, and was enveloped in flame. I did not see the ejection or landing of the pilot due to the smoke and flames from the crash site. My observation was made from the north pad and on the way to the impact area. Due to the monitoring of the radio, if desired, I can give a fair report on the transmissions made from the time we answered the crash call.

4. The above statement is true to the best of my knowledge and belief.

WITNESS

*Richard J. [Signature]*

SIGNATURE

*Billie R. Holmes, TSgt*

**OXGART SECRET**

OXCART

## STATEMENT

9 July 1964

1. I, Sam J. Scamardo, Captain, 57991A, Det 1, 1129th USAF Special Activities Squadron, Las Vegas, Nevada, having first been advised that the purpose of this investigation is not to obtain evidence for use in disciplinary action, or for determining pecuniary liability or line-of-duty status, or to revoke commission or remove from the active list under the provisions of AFR 36-2, or for use before a Flying Evaluation Board, but rather is to determine all factors relating to the accident/incident, and, in the interest of accident prevention, to avert recurrence, do hereby make the following voluntary statement.

2. Identify and qualify witness: Age 30; Duty, Helicopter Pilot; Experience, completed Helicopter School in Oct 61, assigned to ARS LBR unit from Oct 61 to Oct 63. From Oct 63 to present assigned Det 1, 1129th USAF, SAS; Location at time of accident, Sitting in Helicopter on Scramble Alert.

3. At approximately 0850 the crash alarm was sounded and over the crash circuit Bud stated that Dutch 33 was 370 miles North of the Station with his left engine inoperative and he would land runway 32. At this time the alert firemen proceeded to the helicopter and suited out in their "bunkers". The pilot and crew chief remained in the alert room to listen to further developments on the UHF radio since the Dutch was reported to be 370 miles out. A short time after 0900, Dutch 33 reported on UHF radio that both engines were operating but that his "yaw" (Y) system was not operating. After the above radio call by Dutch, the remaining crew members proceeded to the helicopter and the pilot entered the cockpit, strapped in, and had external power applied to the aircraft for radio monitor and quick engine start. After Dutch 33 arrived in the local area and was given landing instructions, Bud asked if any further difficulties were being experienced. The reply was (approx) "There is no further difficulty other than the "yaw" system being out and there is no emergency". Bud replied that the crash equipment would still standby. Just prior to the above radio call by Dutch 33, the helicopter pilot was preparing to accomplish an engine start by notifying the alert crew chief. This action was not performed because of Dutch 33's radio statement, but it was decided to remain in the present standby posture. Shortly prior to 0930, Dutch 33 was observed turning base final and after Roll out on final, he appeared to be flying a normal approach. A few seconds later, the aircraft began a left bank and a fireball was observed coming from the top part of the fuselage. A scramble was immediately initiated and after fire suppression kit hook-up, the helicopter proceeded to the crash area. Upon arrival at the crash scene, a few fires were observed as well as the pilot of Dutch 33 standing near his chute. Sufficient passes were made over the area to assure nothing could be done within the capability of the helicopter. The scramble was then ended and the helicopter returned to the South Ramp and the flight was terminated.

WITNESS



SIGNATURE

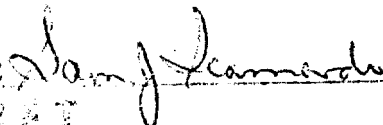

OXCART

SECRET

S T A T E M E N T

9 July 1964

1. I, Leonard H. Smith, Capt., A03087733, Det. 103, 3rd Weather Wing, P. O. Box 882, Las Vegas, Nevada, having first been advised that the purpose of this investigation is not to obtain evidence for use in disciplinary action, or for determining pecuniary liability or line-of-duty status, or to revoke commission or remove from the active list under the provision of AFR 36-2, or for use before a Flying Evaluation Board, but rather is to determine all factors relating to the accident/incident, and, in the interest of accident prevention, to avoid recurrence, do hereby make the following voluntary statement.

2. Age - 32; Duty - Weather Forecaster; Experience - B. S. in Meteorology with 11 years experience in weather forecasting and related fields; Location of time of accident - in weather station.

3. The following information is supplied: 25X1A

a. At approximately 0800, 9 Jul 1964, [REDACTED] entered the weather station for a weather briefing on the Copper Bravo route. The briefing contained the following (non-recorded): Cloud cover (over the area west of a line north-south through the station) - clear; (east of that line) - broken altocumulus bases 16,000 feet, tops 18,000 feet; and thin broken cirrus bases 24,000 feet, tops 26,000 feet at the time of the briefing with the line to move slowly eastward through the period of the forecast. Visibility - 15 miles or better through the period at all altitudes, except within the clouds. Surface winds light and variable at time of takeoff, becoming south southwesterly at 8 to 10 knots at time of landing. The deviation of temperature from standard with altitude was depicted. Light turbulence in the intermediate levels and in the traffic pattern was forecast. Other matters discussed were climatological in nature.

b. Observation of weather conditions at time emergency declared:

0759 PST Record  
Sky - 14,000 scattered  
Visibility - 15 miles  
Temperature - 80 degrees  
Dew Point - 46  
Wind - 160 degrees, 8 knots  
Altimeter Setting - 30.04

~~SECRET~~



Page 2 of STATEMENT by Capt. Leonard H. Smith, A03087733

c. Observation of weather conditions at time of aircraft mishap:

0831 PST Local  
Sky - 14,000 scattered  
Visibility - 15 miles  
Temperature - 81 degrees  
Dew Point - 47  
Wind - 190 degrees, 10 knots gusts to 13 knots  
Altimeter Setting - 30.05

4. The above statement is true to the best of my knowledge and belief:

WITNESS:

Richard J. [Signature]  
Capt USAF

SIGNATURE:

Leonard H. Smith  
Capt USAF

**OXGARY SECRET**

S T A T E M E N T

9 July 1964

1. I, Arthur Patnode, having first been advised that the purpose of this investigation is not to obtain evidence for use in disciplinary action, or for determining pecuniary liability or line-of-duty status, or to revoke commission or remove from the active list under the provision of AFR 10-2, or for use before a Flying Evaluation Board, but rather is to determine all factors relating to the accident/incident, and, in the interest of accident prevention, to avert recurrence, do hereby make the following voluntary statement.

2. Arthur Patnode, crew chief on 133. The aircraft was making an approach. It appeared to me that the approach was nearer to us and his base leg was a little closer than usual. It was normal - that is, the wing nearest me was down into his R/H turn but it appeared to me when he rounded out and was just about facing me that he was at a steeper angle in his bank than usual but not very much. It appeared that he was almost in a 45° bank and they don't usually bank that far. (Which direction was he banked?) He was banking - it was a right bank and it appeared, comparing it with other approaches, that he had it lined up with the runway. I didn't see any evidence of correction. I was standing about 20' in front of the engineering tower. When he was on final it appeared to me he was slightly nose high. Somebody commented that this looked like a kind of sloppy landing and somebody else said that he seemed to settling faster. It did appear to me that it was settling pretty fast. After he had straightened out, he was making his normal approach and it appeared that his nose was a little higher than usual. But then after he straightened out, leveled the wings it appeared to be sinking faster but the rest of it appeared to be a perfectly normal approach. First I was aware of anything wrong was the left wing started to droop and I would guess it was over at about 30° down - left wing down. Then I saw the yellow flash that I thought was a left engine torching. It just continued rotating. I didn't see the chute pop out and others said that this was the chute - this flash was the flash of the rocket and that may very well have been. It was a yellow flash, just like an engine torching and the thing just went on over upside down and that was all I could see. After turning completely over it didn't continue to rotate.

3. The above statement is true to the best of my knowledge and belief.

WITNESS: Richard Johnson

SIGNATURE: Arthur Patnode

OXGART SECRET

~~SECRET~~  
S T A T E M E N T

9 July 1964

1. I, Glenn Holman, having first been advised that the purpose of this investigation is not to obtain evidence for use in disciplinary action, or for determining pecuniary liability or line-of-duty status, or to revoke commission or remove from the active list under the provision of AFR 36-2, or for use before a Flying Evaluation Board, but rather is to determine all factors relating to the accident/incident, and, in the interest of accident prevention, to avert recurrence, do hereby make the following voluntary statement.
2. Glenn Holman, Supervisor, Flight Line. We were standing at the corner of the tower standing by for assistance to tow the aircraft after we had learned that he had lost the left engine in flight. We were just standing there waiting until he made his approach. I understood later that he had gotten his left engine started and we were not necessarily at that time expecting to tow the airplane. We had a radio on in mobile 7 and were listening to his approach. Everything seemed to be normal. I had called off the emergency. The aircraft came around in what appeared to me as a normal pattern and perhaps a little high. As he made his final approach from where I was standing it appeared that the nose of the aircraft sort of pulled up in a little higher angle of attack than normal and then there was a small flash and I could see a parachute open behind the aircraft. Then the aircraft rolled over and struck the ground. (Which way did it roll?) It appeared to roll to the left and nose high. (did this flash occur before he hit?) Yes. (Could you tell where that was coming from?) No, not at the time, but after thinking of it, it appeared that it could have been the seat catapult. That's about all I can think of. The parachute was seen to blossom out when it looked like the aircraft was about in a 45 degree roll.
3. The above statement is true to the best of my knowledge and belief.

WITNESS: Richard J. [Signature]SIGNATURE: Glenn C. Holman~~SECRET~~  
~~SECRET~~

STATEMENT

9 July 1964

1. I, Richard Thomas, AF13336021, 1ST, Det 1, 1129th USAF Sp Acty Sq, P.O. Box 882, Las Vegas, Nevada, having first been advised that the purpose of this investigation is not to obtain evidence for use in disciplinary action, or for determining pecuniary liability or line-of-duty status, or to revoke commission or remove from the active list under the provision of AFR 36-2, or for use before a flying evaluation board, but rather is to determine all factors relating to the accident/incident, and, in the interest of accident prevention, to avert recurrence, do hereby make the following statement.
2. Age 35, and my duties are Air Traffic Control Technician. My location at the time of accident was in the Control Tower.
3. On July 9, 1964 departed for duty, Bud Tower at 0735L. I assumed the duties of Flight Data shortly thereafter. At 0930L Dutch 33 crashed short of Runway 32 on final landing. The following statements are to the best of my knowledge leading up to the accident. At 0857L I received a call from Bungalow stating that D-33, 400 miles out had his left engine out, some duct trouble on the left engine and was also having yaw trouble. This information was immediately passed to all agencies via the crash phone by Sgt Scott. A few minutes later Sgt Scott asked us to contact Bungalow and ask if D-33 needed any tunnel altitudes. Bungalow advised that D-33 stated that if everything went OK he would be well above the tunnel. During all this time we kept all agencies notified of everything. At 0902L Bungalow called and advised that D-33 had his left engine started, but still had Yaw trouble. This info was passed by myself to Boxer C.P. and the crash crew. Sgt Lytton, working local position, advised the road runners. Even though D-33 had his left engine started, we did not terminate the emergency. As D-33 and chase got closer to the station Boxer 14 the chase aircraft requested tunnel altitudes of FL340 and above. The time was approximately 0906L. I called Salt Lake Center and received the altitudes as requested until 0920L. At approximately 0924L D-33 called tower over Blady requesting landing instructions. Landing instructions were given by the local controller, and D-33 was advised that we had called an emergency and every one was standing by. D-33 entered traffic and everything appeared to be normal until the aircraft turned final. At this time the aircraft banked to the left and crashed short of the runway. The time of the crash was 0930L.
4. The above statement is true to the best of my knowledge and belief.

WITNESS

*Richard Thomas*

SIGNATURE

*Richard Thomas*  
RICHARD THOMAS

OXCART

SECRET

S T A T E M E N T

12 July 1964

1. I, Delbert M. Hudson, having been first advised that the purpose of this investigation is not to obtain evidence for use in disciplinary action, or for determining pecuniary liability or line-of-duty status, or to revoke commission or remove from the active list under the provision of AFR 36-2, or for use before a Flying Evaluation Board, but rather is to determine all factors relating to the accident/incident, and, in the interest of accident prevention, to avert recurrence, do hereby make the following voluntary statement.

2. My name is Delbert M. Hudson and I work on 132. I was on the stand watching 133 land. When it was coming in for a landing I saw a ball of flames. It looked like it came out of one of the engines. Then it veered to the left and went over upside down and crashed. (The ball of flame - was it before or after he crashed?) Before he crashed while it was still up in the air. (Where did the flame look like it was coming from?) It looked like it came out of one of the engines - out of the back. It was a big ball of flame. (Did you notice anything else?) No. He was just part way over when I saw the flames in the tail end. (Which way did he go?) He veered to the left and just right on over.

3. The above statement is true to the best of my knowledge and belief.

WITNESS:

Richard J. [Signature]

SIGNATURE

Delbert M. Hudson

**OX CART**

STATEMENT

9 July 1964

1. I, Olga C. Lytton, TSgt, AM12425373, Det 11, 1800 Spt Sq, having been advised that the purpose of this investigation is not to obtain evidence for use in disciplinary action, or for determining pecuniary liability or line-of-duty status, or to revoke commission or remove from the active list under the provision of AR 36-2, or for use before a Flying Evaluation Board, but rather is to determine all factors relating to the accident, and, in the interest of accident prevention, to avert recurrence, do hereby make the following voluntary statement.

2. Age 32, duties-Air Traffic Control Technician, Experience- In career field since 1957, loss of time of accident-Bud Tower.

3. On 9 July 1964, I was on duty and working Local Control Position in Bud Control Tower when Dutch 33 crashed. The weather was VFR, wind was from 140° to 180° at 10 to 15 knots, active runway was 32 left traffic due to students in the gunnery range. At 0857L Sgt Thomas received a call from B-33 that B-33 flying in the SOA had lost left engine, had duct work and fuel trouble and was 370 miles out. Sgt Scott passed this information to the crash phone and advised the crash net that we would call him when we had a better estimate of when B-33 would land. Three minutes later Bungalow called back and told Sgt Thomas that B-33 started the left engine and was OK, except he still had fuel system out. Sgt Scott called mobile control officer in and advised him of this. I advised line control on the FM Line and Scott then went to the radar room. Sgt Thomas then received a call for rescue and he told the pilot of the H-43 what was happening. Sgt Thomas told me that the pilot would wait in the H-43 on the ground and monitor the radio in case he was needed. Sgt Scott then asked me to have Bungalow find out if B-33 would need tunnel altitudes. Sgt Thomas called Bungalow and they said, they would ask the pilot as soon as he passed abeam Bungalow. In three to four minutes Bungalow called back and told Sgt Thomas that B-33 would not need any tunnel altitudes that he would be above the tunnel. Boxer 14 then called on channel 2 at about 0906L and requested tunnel altitudes 340 and above. Sgt Thomas called Salt Lake City Center and was given 340 thousand and above till 0920L which I relayed to B-14. I then got a frequency check with E-43 to see if he was monitoring the frequency and if needed could hear B-33 when he came in. At about 0924L B-33 reported over Bald Mt. and requested landing instructions. I gave him left traffic runway 32 due to students in the gunnery range. At about 0924L I told B-33 that I understood he had fuel trouble and did he have any other troubles. Dutch acknowledged that fuel system was out and everything else was OK and that there was no emergency. I then advised him that an emergency had been declared and crash was standing by. He rogered and about a minute later reported on base. I looked at

OXCART

the position of left base and did not see the aircraft. Sgt Thomas then called to my attention that the aircraft was on right base. The aircraft then turned on final and I told Sgt Thomas "he is sure descending fast". At about 1 1/2 miles on final the left wing dropped, the aircraft fell very fast and crashed about a mile on final to the left of the approach lane. It appeared to blow up as there was much black smoke and dust. I immediately alerted the crash net and then moved back to my position by the console. B-14 gave the position of the pilot, and there were two requests for the position of the M-43 which was approaching the accident scene. B-14 then requested landing instruction on runway 14, which I gave him, but he did not receive the instruction as he had lost his receiver. I attempted contact with B-14 on all UHF radios and Sgt Scott, who had returned to the tower attempted contact with B-14 on SWAB. By this time B-14 was turning final for runway 14 and I gave him a green light to land. I was then relieved by Sgt Scott.

4. The above statement is true to the best of my knowledge and belief.

WITNESS

Earl R. Turrentine

SIGNATURE

John L. Lytle

OXGART SECRET

TAB



**OX CART**  
**SECRET**1129TH USAF SPECIAL ACTIVITIES SQUADRON (Hq Comd)  
P. O. Box 88, Bolling AFB, D. C.SPECIAL ORDER  
XB-354

9 July 1964

The following named Officers and Civilians, organizations indicated, are appointed members of an Aircraft Accident Investigation Board, under the provisions of AFR 127-4. Note: (\*) indicates orders published with approval of Dep/TIG, Hq USAF, Norton AFB, Calif.

<u>GRADE, NAME, AFSN</u>	<u>DUTY</u>	<u>ORGANIZATION</u>
COL ARTHUR F. JEFFREY, 8676A (*)	President	1002 I.G. Group, Norton AFB, Calif.
LT COL FREDERICK C. BLESSE, 17010 (*)	Operations	1002 I.G. Group, Norton AFB, Calif.
LT COL JOHN R. KELLY JR, 35737A [REDACTED] 25X1A	Matériel Contractor Contractor	Det 1, 1129 USAF Sp Actys Sq Det 1, 1129 USAF Sp Actys Sq Det 1, 1129 USAF Sp Actys Sq
MAJOR BRUCE K. KIMBEL, A02083741	Medical	Det 1, 1129 USAF Sp Actys Sq
CAPT RICHARD J. ROUSSELL, 45805A	Recorder	Det 1, 1129 USAF Sp Actys Sq

FOR THE COMMANDER:

*Stephen R. McIlvaine*  
STEPHEN R. MCILVAINE  
Major, USAF  
Asst Administrative Officer

DISTRIBUTION  
D**OX CART****SECRET**

TAB

STATION NELLIS AFB NEV		DATE 7/9/68
TYPE A/C	A/C NO. Dutch 33	MISSION X-1

OCCUPANTS (State whether crew or passenger. List additional passengers on reverse.)

DUTY SYMBOL	NAME AND INITIALS	GRADE	SERVICE NO.	HOME STATION
P	[REDACTED]		Civ	NTS
	25X1A			

ETO 0815	ETE (Home base) 1+	HOURS OF FUEL 1+30	AUXILIARY BASE OF 1ST INTENDED LANDING
FORM "F" FILED AT NELLIS AFB NEV		DATE FILED (Day, month, year)	

WEATHER IS FORECAST TO REMAIN VFR FOR THE DURATION OF THIS FLIGHT. I AM FAMILIAR WITH ALL CURRENT REGULATIONS AFFECTING THIS FLIGHT AND THIS FLIGHT WILL BE CONDUCTED IN ACCORDANCE WITH SUCH REGULATIONS.

[REDACTED]	25X1A	PIF [REDACTED]
ACTUAL DEPARTURE 0819L	ACTUAL ARRIVAL 0929L	25X1A

REMARKS

P. A. ....

TEMP. ....

T/O ROLL .....

ROLL ..... (W/CHUTE)

..... (W/O CHUTE)

PIF Nbr. ....

**OX CART SECRET**

Approved For Release 2001/08/29 : CIA-RDP71B00590R000100040001-1

TYPE AIRCRAFT

*C46*

*133*

*9 July 64*

~~WEATHER:~~ \*Including enroute terminal forecasts

~~STATUS OF AIRFIELD FACILITIES.~~

~~HAZARDS:~~

~~HAZARDS TO AIRCRAFT GROUND OPERATIONS:~~

~~RESTRICTIONS TO LOCAL AREA IMPOSED BY MFR, MOUNTAINS, CANYONS, ETC.~~

~~ADDITIONAL INFORMATION PERTINENT TO FLIGHT:~~

~~SPECIAL FLIGHT SAFETY ISSUES:~~

\*Weather briefing to accomplish IFR and/or VFR flight to be conducted

SPECIALIZED MISSION BRIEFING

The pilot designated on flight orders as primary or secondary pilot shall be responsible for specialized mission briefings to include the following items:

TECHNIQUES USED DURING SCHEDULED TRAINING ACTIVITIES.

APPLICABLE EMERGENCY PROCEDURES:

FOR 1-33's EJECTION, LOW ALTITUDE OR DOWN LANDING PROCEDURES.

FORMATION FLIGHTS : FLIGHT LEADER WILL CONTACT FLIGHT LEADER TO INTERCOM.

General mission briefings will not be taped.

Specialized Mission Briefings will be taped.

A copy of this form will be attached to the clearance.

*Richard J. Russell*  
GENERAL MISSION BRIEFING OFFICER

SPECIALIZED MISSION BRIEFING OFFICER

The above checklist is IAW SOP 50-3055-11, dated 17 October 1963

Approved For Release 2001/08/29 : CIA-RDP71B00590R000100040001-1

**OX CART SECRET**

TAB

**OXCART      SECRET**

STATEMENT OF DAMAGE

9 July 1964

Investigation has revealed no damage to private property as a result of this accident. The aircraft struck the ground at a location on which neither vegetation nor habitation was situated.

**OXCART      SECRET**

TAB

**OXCAET SECRET**

CERTIFICATE OF DAMAGE

9 July 1964

The aircraft was totally destroyed upon impact.

**OXCAET SECRET**



TAB

SECRET

Approved For Release 2001/08/29 : CIA-RDP71B00590R000100040001-1  
Extract from Control Tower logs involving major aircraft accident, number 133 at Det 1, 1129th USAF Sp Acty Sq, Las Vegas, Nevada, 9 July 1964

FOLLOWING ARE EXTRACTS FROM TOWER TAPE

EMERGENCY NOTIFICATION OF EMERGENCY

<u>LOCAL TIME</u>	<u>AGENCY CALLING</u>	<u>MESSAGE</u>
0855	Bungalow on H Line to Bud	"He's having a little engine trouble. He just shut his left one off - he's about 400 mile north inbound to you about 160 degrees".
	Bud	(Acknowledged)
0856	Bungalow	"He's still having trouble with his left duct. His range is 370 mile from you."
0857	Bud	"Cush not activated. "Dutch 33, 370 mile out inbound left engine shut down, will pass on landing estimate when received - will be landing runway 32".

CHANNEL 6

0901	Bud	"Dutch 33 will you require a tunnel altitude?"
0902	D-33	"Negative, I'll be quite a way over that if everything continues to go like it is right now."
	Earth	"Dutch 33, over".
	D-33	"Roger go ahead."
	Earth	"Do you have the left engine out - still?"
	D-33	"Negative, the left engine is running. Everything is OK except for YAW A".
	Earth	"Roger, we'll have the staff car ----- (unreadable)", "what's your ETA?"
	D-33	"I'm going to abort going around the course. I'd say about 15 minutes".
	Earth	(Unreadable)
	D-33	"Maybe 10".

CHANNEL 2

0901	Roadrunner 3	"Bud how do you read mobile?"
	Bud	"Loud and clear mobile".

OX CART SECRET

~~SECRET~~

Roadrunner 3 "Bud is 33 on Channel 6 or this one"?

Bud "Haven't heard from him he's quite a bit north yet".

0903 Bud to Command Post (Hot Line) D-33 has left engine running now, still no yaw aid. Leave emergency status as it could go back on again.

0904 Roadrunner 2 "Roadrunner 3 this is Roadrunner 2", no answer.

B-14 "Bud Boxer 14".

Bud "Boxer 14 Bud".

B-14 "I'm just north west of Mackerel coming in with 33, have not joined up with him yet. Could I come across the tunnel at 340 and above please"?

Bud "Standby one".

Bud "Roadrunner 2 and 3 D-33 now has left engine running. Yaw A system out only".

Roadrunner 3(?) "Roger, understand".

0905 Bud "Boxer 14 Bud".

B-14 "31 go".

Bud "Flight level in tunnel 340 and above approved now until 20 past the hour".

D-14 "Roger understand and we'll be on Channel 6".

0915 Operations "Weather warning passed to Tower.

Bud "Weather warning passed to mobile.

0916 Roadrunner 3 "Where are you going to land 33 on 32"? (No answer).

BOXER 12 enters traffic and 140000 0920.

0922 Bud "Mobile, 33 is now 25 miles out estimating landing in 5 to 10 minutes".

Roadrunner 3 "Roger".

0923 Communications check with B-43, also B-14 and D-33 check in on Channel 2.

~~SECRET~~

~~OX CART~~ ~~SECRET~~

0924 D-33 "D-33 over baldy for landing".  
Bud "33 left traffic runway 32 wind 140 degrees variable 130 degrees 4 gust to 8 altimeter 3005, foreign students in gunnery range".  
Bud "33 understand yaw A system inoperative, do you have any other troubles?"  
0925 D-33 "Negative, no emergency required".  
Bud "Roger, emergency has been declared and crash is standing by".  
D-33 "OK".

Various other conversations concerning next Dutch flight between Bud and Mobile, and Dutch 31 calls for radio and parrot check.

0928 D-33 "33 on base, gear is down and locked".  
Bud "33 check limiter cleared to land, wind 150 degrees variable 4 peak gust 8".  
D-33 "Roger" (NOTE: Last comment from D-33).  
0929 Roadrunner 2 "Call crash Bud, call crash".  
B-14 "Bud the pilot is off the west side of the aircraft, he got clear I hope".  
B-14 "Bud 14 do you read"?  
Bud "14 Bud".  
B-14 "The pilot is on the left side of the aircraft about 100 yards".  
Mobile "Roger, mobile copy".  
0930 Bud "14 do you copy"?  
B-14 "Roger, right next to the road".  
Bud "43, pilot left hand side 100 feet clear of aircraft".  
B-14 "Where's our chopper"?  
Bud "He's on the way".  
Roadrunner 2 "Bud Roadrunner 2, where's the chopper"?  
Bud "He's approaching at the present time, about half way there".

~~OX CART~~ ~~SECRET~~

OXCART

SECRET  
Approved For Release 2001/08/29 : CIA-RDP71B00590R000100040001-1  
ENGINEERING FLIGHT TEST

MODEL A-12 SERIAL 133 DATE 9 July '64 OBSERVER \_\_\_\_\_ PILOT \_\_\_\_\_ FLIGHT 10 Test 13

TEST: RECORDER NOTES 25X1A

Dutch 33 taxiing out. Bud, dutch 33, go ahead.  
 Need an unrestricted climb and I'll need a trim run. I'll take it.  
 Left brake very weak on this vehicle.  
 I've got 6750 rpm, 808 EGT, Nozzle 1.0, F/F 15400, oil press 48, temp about 100 on oil.  
 RPM-wise I have 6925, EGT looks like about 806, nozzle 1.5, F/F 16100, oil pressure 42, oil temp 75, 9 dash 7 is fifty eight two. Pull the chocks.  
 Dutch 33 ready to roll. Rog. - - -  
 Seat is still loose in this airplane. Rog. - - -  
 Right EGT wandering around a bit, left one is pretty good. At 1.18 Mn, 812 left right 786.  
 Roger, loud & clear. Lets go to channel 6 and check communications.  
 Roger, you're loud and clear. Bungalow, 33 how do you read? Loud & clear, Rog.  
 Right oil pressure about 40 and the left is about 48. Temp on left is about 100 and on the right its about 75.  
 - - - 50 degrees, 786 left, 802 on right. RPM on left is about 7025 and on the right 7050. I got the ball out to the right about a third and I have 790 left and 810 right. Cut down a bit on the right. Left nozzle is going wide open. There's the time - 12 minutes and 45 seconds to 2.2 Mn.  
 Left nozzle is wide open and I've got 790 Temp at 2.21 and I've got 7290 rpm. The right set up is 7300 rpm, 800 EGT and about 7.5 on the nozzle.  
 OK, 3.8 (2.8) now it looks like the ball has gone back into the center.  
 2.41 I felt the oil canning up in the front end. A little roughness here at 2.52. Hello dutch 33 - do you have me approaching Burley? Roger, thank you.  
 2.67 now and the left oil pressure is about 42 and right is about 38. Temp 150 left, 125 right. I'm cruising here at 2.8 and I have about 28000 lbs of fuel left and I'm coming up here on Dillon, 335 KEAS. 33 is starting a turn around.  
 Roger, loud & clear, standby. What does this heading look like? I just lost my left burner. I have it going again now. Bungalow, how does my heading look? Bungalow, this is dutch 33. I got a problem here. I can't get my left duct pressure up and I'm going to continue on this heading and see what develops. My heading is 155 you say? Rog. You may relay that I've lost SAS yaw A. Lost yaw A.  
 Holy mackerel, I had 850 on that left engine.  
 Bungalow, correction. My left engine is not shut down now. I have it running. Left oil pressure is down to about 38, right oil pressure down to 35. Left oil temp is around 212 and the right is around 175.  
 I'll be quite a ways over that if everything continues to go like it is right now. Roger - Roger, earth, go ahead. Negative, the left engine is running and everything is OK except for yaw A. Rog. I'm going to abort going around the course and I don't know, lets see I'm - lets say 15 minutes.  
 - - loud & clear, go ahead. Rog, Rog. Now passing west of Mackerel and quite high. Left oil pressure around 38, the right is 35 or lower and the left oil temp is 212 and the right is 175 or 177. I'm almost over Tonopah - going to make a gigantic 360 around the base. This oil temp is about 212 on the left and about 170 on the right.  
 Roger, I'm decelerating now. I'm over to the east about 75 miles. Large left turn - probably the reason. I'm now northwest of the airport still decelerating.

OXCART SECRET

**OXGART**

**SECRET**

Approved For Release 2001/08/29 : CIA-RDP71B00590R000100040001-1

**ENGINEERING FLIGHT TEST**

PAGE \_\_\_\_\_ OF \_\_\_\_\_

MODEL A-12 SERIAL 133 DATE 9 July '64 OBSERVER LAIRD FLIGHT 10 TEST 13

TEST: RECORDER NOTES - Cont.

Dutch 33 going over to channel 2. Roger, Bud, Dutch 33 over Baldy for landing. Negative, no emergency required. OK, 27000 feet I'm frosting from the apex of the windshield back to about midway and it gets larger as it comes aft toward me. I'm giving it full de-fog. I'm getting a shorted out system and number two tank is shorted out when this happens on the fuel. 33 is on base, gear is down and locked. Rog. When I trim, just the right rudder trims, as ..... the indicator .... (tape ripped at this point)

Approved For Release 2001/08/29 : CIA-RDP71B00590R000100040001-1

**OXGART**

**SECRET**

~~OR~~ ~~SECRET~~

ANALYSIS OF CRASH RECORDER TAPE

1. The cassette and remains of foil record, as received, indicated that it had been subjected to severe impact damage.
2. It was unfortunate that the whole recorder could not be returned. The pearlite impregnation of the pieces received would tend to indicate that even if the recorder case separated completely, most of the debris would have been retained. Careful sifting could well have provided most of the foil pieces containing the record of the end of the flight.
3. As received however, all the exposed foil at the time of impact was missing. The precise amount is not known, but our readout provides a positive record of time from lift off on the last flight up to 63 minutes and 15 seconds of flight time.
4. With regard to the last flight of s/n 133 the data indicates that the airspeed trace was lost at a value of approximately 400 knts as the ship climbed through 25,000 feet. This was approximately 66 minutes before impact. The altitude trace was lost approximately 18 minutes before impact with an indication that altitude was just starting to be reduced from the 70,000 foot level. The reduction in altitude is verified by the vertical acceleration trace which shows a pushover to less than one "g" coincident with the reduction of altitude. The vertical acceleration trace was lost approximately 7 minutes before impact with the aircraft at that time being in 1 "g" flight. The Heading Trace was obviously not working during the entire flight.

~~OR~~ ~~SECRET~~

**OXCART SECRET**

**APPENDIX A  
READ OUT FIGURES**

**RECORDER 3N 84B**

TIME		ALTITUDE	AIRSPEED	VERTICAL ACCELERATION	HEADING	REMARKS
MIN	SEC					
-1	0	0.202	1.610	1.200	0.372	COMMENCEMENT OF A/S ACCELERATION
-0	45	0.195	1.578	1.220		
0	00	0.178	1.407	{1.318} {1.103}		LIFT OFF (BLIP ON HDG TRACE) VIB ON 'g'
+0	15	0.182	1.415	{1.260} {1.120}		
+1	15	0.439	1.155	{1.260} {1.130}		
+2	15	0.802	1.120	{1.250} {1.140}		COMMENCEMENT A/S TRACE SLASH
+2	50	0.960	1.117	{1.220} {1.180}		
+3	15	0.945	1.117	{1.260} {1.130}		
+4	15	0.982	1.117	{1.210} {1.190}		
+4	45	1.000	1.117	{1.210} {1.190}		END OF A/S TRACE
+5	15	1.031	NO TRACE	{1.210} {1.190}		
+5	45	1.063		1.200		'g' STEADY
+6	15	1.095		{1.240} {1.160}		FIFTEEN MINUTE MARK
+7	15	1.170		{1.230} {1.170}		
+8	15	1.211		1.200		'g' STEADY
+9	15	1.274		1.195		
+10	15	1.363		1.185		
+11	15	1.430		1.199		GAP IN 'g' TRACE
+11	45	1.456		1.200		END GAP
+12	15	1.478		1.199		
+12	45	1.477		1.195		DIP IN ALTITUDE
+13	15	1.492		1.188		
+13	45	1.535		1.220		LEVEL FLIGHT
+14	15	1.535		1.199		
+15	15	1.552		1.200		'g' STEADY
+15	45	1.563		1.205		VIB RECOMMENCES
+16	15	1.584		1.215		
+17	15	1.595		1.210		
+18	15	1.602		1.205		
+19	15	1.606	NO TRACE	1.202	0.372	

**OXCART SECRET**



OXGART SECRET

Approved For Release 2001/08/29 : CIA-RDP71B00590R000100040001-1

APPENDIX A  
READ OUT FIGURES

TIME		ALTITUDE	AIRSPEED	VERTICAL ACCELERATION	HEADING	REMARKS
MIN	SEC					
+20	15	1.623	NO TRACE	1.200	0.372	VERTICAL GASH TOP OF "g" TRACE
+21	15	1.628		1.190		FIFTEEN MINUTE MARK
+22	15	1.635		1.200		"g" HGT EST. - SEVERE WRINKLING
+23	15	1.640		1.200		BOTH EST. - TAPE CRUMPLED
+24	15	NO TRACE		{1.220} {1.180}		ALT. TRACE LOST - SCORING & WRINKLING
+25	15			{1.220} {1.180}		
+26	15			1.210		WEAK "g" TRACE
+27	15			{1.210} {1.170}		
+28	15			1.200		ALT. TRACE GAP STARTS - "g" TRACE WB.
+29	15	NO TRACE		{1.200} {1.150}		
+30	15	1.650		{1.200} {1.150}		END OF GAP IN ALT. TRACE
+31	15	1.650		1.160		
+32	15	1.657		{1.200} {1.160}		
+33	15	1.652		1.190		
+34	15	NO TRACE		1.200		ALT. TRACE GAP STARTS
+35	15	NO TRACE		1.190		
+36	15	1.690		{1.230} {1.200}		ALT. GAP ENDS & RESTARTS - 15 MIN. MARK
+37	15	NO TRACE		1.200		
+38	15	NO TRACE		{1.270} {1.190}		
+39	15	1.658		1.185		END OF GAP IN ALT. TRACE
+40	15	1.661		1.200		
+41	15	1.670		1.210		
+42	15	1.662		1.205		
+43	15	1.661		1.200		
+44	15	1.665		1.205		
+44	45	1.661		1.200		
+45	15	1.662		1.200		
+46	15	1.660		1.200		
+47	15	1.663		1.200		
+48	15	NO TRACE		1.200	0.372	

Approved For Release 2001/08/29 : CIA-RDP71B00590R000100040001-1

OXGART SECRET

OXCART

SECRET

APPENDIX A  
READ OUT FIGURES

TIME		ALTITUDE	AIRSPEED	VERTICAL ACCELERATION	HEADING	REMARKS
MIN	SEC					
+49	15	1.660	NO TRACE	1.200	0.972	START OF GAP IN "g" TRACE
+50	15	1.665		NO TRACE		
+51	15	1.655		1.150*		"g" PROBABLY 1.200-FOIL DISTORTED 15 MIN
+51	45	1.650		1.150*		END OF FOIL IN ALT. TRACE AREA
+52	15	NO FOIL		1.150*		
+53	15			1.150*		
+54	15			1.150*		TEAR IN FOIL-END OF DISPLACED PORTION
+55	15			1.175		
+56	15			1.175		
+57	15			1.175		
+58	15			1.200	0.972	"g" TRACE ENDS
+59	15			NO FOIL	NO TRACE	HDG TRACE FADES OUT
+60	15					
+61	15					
+62	15					
+63	15		NO TRACE			
+63	45	NO FOIL	NO FOIL	NO FOIL	NO TRACE	END OF FOIL

OXCART SECRET

Approved For Release 2001/08/29 : CIA-RDP71B00590R000100040001-1

ALTITUDE FEET	VALUES REFERENCE	ALTITUDE FEET	VALUES REFERENCE	AIR SPEED KNOTS	VALUES REFERENCE	ACCELERATION G'S	VALUES REFERENCE
0	1.878	1000	-.046	0	1.595	1	1.689
20	1.675	2000	.000	100	1.572	2	1.567
40	1.474	3000	.090	150	1.487	3	1.441
60	1.282	4000	.134	200	1.420	4	1.321
80	1.081	5000	.178	250	1.351	5	1.191
100	.879	6000	.263	300	1.282	6	1.075
120	.674	7000	.350	350	1.213	7	.820
140	.470	8000	.436	400	1.145	8	.581
160	.268	9000	.517	450	1.078	9	
180	.073	10000	.598	500	1.011	10	
200	.275	11000	.676	550	.944	11	
220	.474	12000	.752	600	.877	12	
240	.673	13000	.826	650	.809		
260	.871	14000	.897				
270	.973	15000	.996				
280	1.075	16000	1.147				
300	1.273	17000	1.273				
320	1.474	18000	1.384				
340	1.677	19000	1.535				
360	1.878	20000	1.615				
		21000	1.670				
		22000	1.705				
		23000	1.727				
		24000	1.742				



LOCKHEED AIRCRAFT SERVICE, INC.  
ONTARIO, CALIFORNIA

CALIBRATION CHART  
SAS MODEL 109-C FLIGHT RECORDER

PREPARED BY

DATE

FORM NO. 210

Approved For Release 2001/08/29 : CIA-RDP71B00590R000100040001-1

TAB

OPERATIONS

AND

WITNESS

GROUP

**SECRET**OPERATIONS AND WITNESS GROUP

Investigation of major accident involving A-12 Aircraft S/N 133 which occurred at Det 1, 1129th SAS, Las Vegas, Nevada, on 9 July 1964.

A. HISTORY OF FLIGHT

25X1A [REDACTED] was scheduled to fly A-12 aircraft #133 on 9 July 1964. He was fully qualified in all respects for pilot on this mission. The mission objective was maximum A/B climb to 2.8 mach and sustained flight at 2.8 mach. The route to be flown was Copper Bravo route (see attached map). Weather was excellent and had no bearing on the accident. Aircraft inspection and personal equipment hook-up was performed by qualified ground crew in accordance with flight handbook and organizational procedures. The aircraft weight was 112,000 pounds as the aircraft began its take-off roll. After 7400 feet of roll at 210K the aircraft became airborne. Time was 0820 PDT. An F-101, #312 piloted by Colonel R. J. Holbury and Captain R. J. Russell was being used as chase within the capabilities of the aircraft. Chase reported #133 clean and smooth after take-off. Both aircraft checked in with Bungalow who advised good IFF/SIF contact. [REDACTED] performed a max A/B climb to 78,000 and 2.8 mach. At the northern limit of Copper Bravo route which is near the Canadian border, the pilot turned left and began the south bound leg. Onion slicers were closed down about 20 percent as planned. This action is normally used to reduce turbulence in the intake duct. The primary shock wave moved forward causing the engine duct ("popped the shock") at this time. The "A" yaw stability augmentation system (SAS) was lost also and could not be recovered. Since "B" yaw system was normal and accomplished the same function, no change in flight plan was required. The pilot lost A/B on the left engine but was able to relight. After relight thrust was down on the left side but operation of the by-pass doors, onion slicers and spike returned the thrust to normal. Movement of the spike is used to position the shock wave in the intake duct. The "A" yaw system remained out. The pilot accelerated to 2.8 mach and headed for home base with both engines performing smoothly. Upon arrival in the local area a total of 35 minutes had been accomplished at mach 2.8. Landing gear was extended at 30,000 feet and Mr. Park began his descent for landing. The chase aircraft joined with A/C #133 while descending in a left turn over the station at 28,000 feet. Descent was rapid with little or no power being used. The lower portion of the front windscreen fogged up. Downwind was 16,000 feet, base leg 12,000 feet. Turn onto final was smooth and reasonably steep. After aircraft #133 had been straight on a descending final for about one mile, (altitude 500 feet, airspeed approximately 200K) the aircraft began a smooth steady roll to the left. The pilot applied full right elevon and added power but the aircraft continued its steady 25X1A roll to the left. At approximately 200 feet altitude [REDACTED] ejected. The aircraft continued its left roll, struck the ground inverted, exploded and burned. The pilot was dragged toward the fire in his parachute after landing but managed to spill the chute using the risers. The quick release was too difficult with gloves on. Other personal equipment performed as designed. The mobile control officer was first on the scene to aid the pilot. He was followed closely by two noncommissioned officers riding toward the base on the road paralleling the flight path of the aircraft. All helped the pilot out of his pressure suit and aided in his immediate removal to the dispensary for medical check up.

**SECRET**

~~SECRET~~ SECRET

B. INVESTIGATION AND ANALYSIS

1. There were four primary areas of suspect that were explored by the Operations Group in attempting to determine the cause of this accident.

a. Numerous witnesses stated they saw an explosion near the left engine and pieces coming from the aircraft before the aircraft crashed. (See witnesses statements thru report). Engine failure and/or an explosion on the left side could possibly have caused the conditions that existed prior to the crash so these witnesses were interviewed carefully. None had ever seen a pilot eject using the rocket ejection seat. Questioning revealed the fact that all saw the fire after the aircraft began its roll to the left. It was at this time the pilot ejected so it must be assumed they were observing operation of the rocket seat. To substantiate this, investigation of engines confirmed the fact that all fire was post impact fire and that no explosion in or around the engines occurred in flight.

b. A second possibility is that the pilot had too steep an approach and actually stalled the aircraft in attempting to reduce the sink rate. This theory had to be discarded for several reasons. First the pilots own testimony indicated he lowered his airspeed as around 200Kts at the time the aircraft began its final approach speed is approximately 175Kts minimum over the runway and touchdown about 145Kts. Secondly the chase pilot, who was within 100 feet of the accident aircraft on the final approach, reported his airspeed in excess of 200 Kts. Third, the flight characteristics of the P-101 approach speeds are inferior to those of the A-12 and, if any difficulty had been encountered for this reason, the P-101 would have also had trouble.

c. A third suspect was the rudder trim system. On base leg the pilot made a taped recording on I trim, just the right rudder trims, as ---- the indicator ----. The tape ripped at this point so nothing further was recorded. Careful investigation indicated both trim actuators were similarly positioned at the time of impact and the trouble was therefore in the indicator only. In addition the pilot later stated he had no yaw problems whatsoever on the final approach.

d. The fourth possibility, and the one which this Board feels is the primary cause of this accident, is that the right outboard elevon servo was binding which inturn caused the right outboard elevon to be positioned in the full down position. Taking the evidence available after the crash, the pilots statement and various witness reports the following sequence of events can be established.

(1) The pilot made a right turn on to final approach for landing after a relatively rapid spiral descent from a flight condition of Mach 2.8 and 78,000 ft. During the descent at approximately .9 Mach and 300 KEAS the gear was extended for the purpose of increasing rate of descent. 4000 pounds of fuel was transferred to tank No. 1. While in the landing pattern the speed was bleed off to the 200 KEAS existing in the final approach leg in excess of one mile from the end of the runway. Rate of descent during final was reported to be higher than usual. Low throttle

~~SECRET~~ SECRET

**SECRET**

settings were reported used during final approach. A slight roll off to the right was corrected by the pilot with a left roll input. The aircraft then started to roll left. The pilot started applying a slow right aileron input to correct the left roll. At least in the initial statement the pilot felt that he had checked or slowed the roll at first. At no time did the pilot note deviations from 1 g flight. Due to the roll condition the pilot considered a go around and started applying throttle. Almost simultaneously with throttle movement he hit the aileron stick travel limit. With no control in roll he ejected at approximately 200 feet altitude from the steeply banked aircraft. The aircraft continued to roll and is estimated to have impacted at an attitude of approximately 216 degrees of left bank with the right wing tip making first contact. Evidence obtained from the wreck tends to indicate the following conditions existed on impact. The airspeed was 214 KEAS. The outboard right elevon was positioned at approximately 20 degrees trailing edge down. The aircraft controls were trimmed to approximately zero in roll and yaw and 2.4 degrees trailing edge up on the inboard elevons in pitch. A review of the scene indicated that the nose of the aircraft hit slightly after the wing tip implying that the aircraft was at a slight nose up attitude. Reviewing the events and evidence presented above with the assumption that the right outboard elevon valve had jammed in a open condition the following conclusions can be drawn. The action of the pilot to correct for a right roll-off or possibly a small pitch or roll damper input, would be sufficient to crack the valve to an open position whereupon it could jam, resulting in driving the right outboard elevon to the hardover position in which it was found. It is apparent from pilot comment that the valve did not jam full open since in that event, with the surface moving at 30 degrees per second the pilot would have lost roll control in .29 seconds and had a hardover condition in .85 seconds. This is contrary to his statement that he applied corrective action slowly. In addition the pitch transient would have been quite severe. The lack of comment on a severe pitch transient and the slow input of corrective aileron establishes the fact that initially the surface was drifting hardover slow enough to be well within the pilots capability to apply corrective action. To maintain 1 g flight requires little more than a small back pressure on the stick during the time that corrective aileron is applied. However, when the right outboard elevon has reached a point of 3.3 degrees trailing edge down on a total movement of 8.7 degrees from the trim position, the mechanical stops on differential elevon available are reached and roll control is lost. Prior to this point the left roll could have been slowed or checked as initially indicated by the pilot. Once roll control is lost the roll rate will build up to approximately 27 degrees per second as the hardover outboard elevon position is reached, which seems to be consistent with pilot and witness reports. After the pilot ejects the outboard elevon will return to the neutral position. Thus the aircraft is out of control in both roll and pitch. The roll rate would increase to approximately 41 degrees per second and a large nose down pitching moment would be applied. The nose down moment applied to the inverted aircraft would explain why the aircraft impacted in an almost flat to slightly nose high attitude. The descent of the aircraft would explain the buildup in speed to 214 KEAS at impact.

3

**SECRET**



SECRET

C. SUMMARY AND ANALYSIS OF WITNESS STATEMENTS

Many aspects of the testimony even by on the spot witnesses proved to be inaccurate and incorrect. This was caused by the activation of the rocket seat shortly after the aircraft began to roll to the left. From the beginning of the roll to aircraft ground impact was probably not in excess of 3 to 4 seconds. During this time witnesses were exposed to aircraft roll, canopy separation involving 3 or 4 pieces, rocket seat ejection, the pilot's parachute opening and the crash and explosion of the aircraft. Inconsistencies existed in direction of aircraft roll, explosion near left engine before aircraft impact, parachute opening and attitude of the aircraft at the time of impact. Fortunately all of these things could be determined accurately by structures personnel.

D. FINDINGS

1. The pilot was on an authorized flight.
2. The pilot was qualified, current and proficient in the A-12 aircraft.
3. Neither AFCS facilities nor weather were considered to be a factor in the accident.
4. The pilot was adequately briefed.
5. Difficulties encountered with the left inlet system and/or engine during flight had no bearing on the accident.
6. Limiter handle had been pulled giving the pilot full 50°/sec. elevon roll capability. (Versus 30°/sec. capability with limiter engaged).
7. Final approach was steep but not to an excessive degree.
8. Airspeed on final approach was approximately 200 KIAS ± 10 KIAS.
9. Airspeed at time the aircraft began to roll was sufficient to reach the runway, accomplish a normal flare and landing without the use of additional power.
10. The pilots actions had no bearing on the accident.
11. No film coverage of the accident was available.

E. RECOMMENDATIONS

That all landings and take-offs be filmed with film processing being accomplished only if a requirement exists.

SECRET

**OXGART SECRET**

*Frederick C. Blesse*  
FREDERICK C. BLESSE, LtCol, USAF  
Directorate of Aerospace Safety  
Norton AFB, California

*Raymond L. Haupt*  
RAYMOND L. HAUPT  
LtCol, USAF  
Det. 1, 1129th SAS 25X1A

25X1A



Lockheed Aircraft Corp.



Lockheed Aircraft Corp.

**OXGART SECRET**

STRUCTURES,

FIRE

AND

EXPLOSION

GROUP

STRUCTURAL, FIRE AND EXPLOSION GROUP

INVESTIGATION OF MAJOR ACCIDENT INVOLVING A-12 AIRCRAFT S/N 133  
WHICH OCCURRED AT DET. 1, 1129TH SAS, LAS VEGAS, NEVADA, ON 9 JULY 1964

A. Aircraft Impact:

From observation of the impact marks on the ground and examination of the wreckage, the aircraft contacted the earth in an inverted position with the right hand wing tip and the top of the right hand rudder hitting the earth first. See Figure 1, Tab Y. Upon impact, the aircraft disintegrated with resultant explosion and fire. The scatter pattern along the flight path from the point of impact is shown in Plot Plan (Figure 2, Tab Y). Figure 3, Tab Y shows the Plot Plan of airframe structure components.

B. Investigation and Analysis:

1. The aft end of the fuselage housing the control system mixer had discoloration as a result of being in a fire. Examination of this piece of wreckage revealed that the heating occurred after impact. Also other parts were examined that had fire and heat indications. These also were determined to be post impact. An example of these parts were the bracket supports in the vicinity of the oxygen bottles. These brackets were severely distorted and heat discolored as were the engine control cables running in pulleys in the brackets. These cables were broken in each individual strand at right angles to the surface. There were no necking or 45° shear plane failures. Also the wires were stiff and had no ductibility. Examination revealed that heating caused the change in physical characteristics. The analysis of the brackets showed that they were torn and deformed prior to the fire impingement. Since several witnesses said they observed fire in flight on the right hand engine. Particular emphasis was expended to examine the engine. There were just several local areas that had been subjected to heat and/or fire. Each of these fire areas were determined to have been post impact. Other burned structural parts found in the impact area were examined to determine whether or not the burning took place prior to impact. All burning was indicative of post impact fire. The burned area was wide spread as shown in Figure 2, Tab Y.

2. A small piece of titanium sheet spot welded to a titanium Z stringer was found approximately two miles back along the flight from the point of impact. The piece measured approximately nine by twelve inches. On the stringer was printed the part number AF 364-27. This part is called out in DWG AF 364 sheet #4, (Fillet installations, Tail cone). The parts of Aircraft 133 in this vicinity were examined and the particular part that was found could not have come from 133 since all parts of both right and left fillet panels are accounted for with no missing parts. Hence the part found could have come from an earlier aircraft early in the program that was known to have shed parts.

3. All three landing gears were downstream from the impact point. This indicates that the aircraft was inverted and also that the gears were extended.

**OXCART**

**SECRET**

~~SECRET~~

4. All extremities of the aircraft were accounted for in the impact area as well as all doors and hatches.

C. Findings:

1. There was no fire or explosion in flight.
2. The aircraft was structurally airworthy prior to impact.

D. Recommendations:

None  
25X1A



Directorate of Aerospace Safety

25X1A



Structure Design  
Lockheed Aircraft Corporation

~~SECRET~~

~~SECRET~~

POWER PLANT

AND

FUEL SYSTEM

GROUP

~~OXGART SECRET~~

POWER PLANT, FUEL AND OIL SYSTEMS

INVESTIGATION OF MAJOR ACCIDENT INVOLVING A-12 AIRCRAFT S/N 133 WHICH OCCURRED AT DET 1, 1129TH SAS LAS VEGAS, NEVADA ON 9 JULY 1964

A. Power Plant

1. Description:

a. The YJT11D-20A (YJ-58) is rated for continuous operation at maximum thrust at high mach number and high altitude. Several unique features make this possible:

(1) Utilization of a bleed bypass cycle for high mach number operation.

(2) Scheduling of rotor speed to control engine airflow for improved inlet-engine matching.

(3) Unlimited operating time at mil and max thrust.

b. The bleed bypass system provides improved compressor turbine matching at high mach number by allowing 4th stage compressor air to bypass the 4th and 5th stages of the compressor. The bypass air re-enters the engine at the inlet of the afterburner so that the air may be used for increased thrust augmentation. Transition to the bypass regime is automatically sequenced by the main fuel control at a compressor inlet temperature of 100 to 125° C (approximately mach 2.0).

c. Inlet-engine compatibility is accomplished by means of fuel control scheduling of engine rotor speed by a variable area exhaust nozzle. At a given flight condition the engine will maintain constant rotor speed and airflow over a wide range of power lever positions from below military rated thrust to maximum thrust. As mach number (inlet temperature) is varied, rotor speed varies as scheduled by the fuel control even though the power lever remains fixed.

d. The engine has a single rotor, nine stage, nominal 8:1 pressure ratio compressor. The combustion section is of conventional can-annular configuration. Variable area fuel nozzles are used, six to each burner can, 48 per engine.

e. The two stage turbine has air-cooled first stage blades and vanes. Exhaust gas temperature instrumentation is provided for monitoring turbine temperature.

f. The engine has three main bearings: Nbr. 1 at the front of the compressor, Nbr. 2 (thrust bearing) at the rear of the compressor, and Nbr. 3 at the rear of the turbine.

~~OXGART SECRET~~

g. The engine bleed air system is conventional, cooling is accomplished completely by the fuel flow to the main fuel nozzles.

h. The engine is equipped with a chemical ignition system using pyrophoric triethylborane (TEB) to ignite the low vapor pressure fuel. The system is automatic and is completely self contained in a fuel-cooled engine mounted unit. The one unit serves both the engine and the afterburner.

i. Afterburner thrust modulation is obtained by varying the power lever position in the A/B range. The main fuel control varies the exhaust nozzle area to maintain the scheduled rotor speed. Exhaust nozzle actuation as well as the compressor bypass system and start bleed system is hydraulic, employing engine fuel as the hydraulic fluid.

j. Both the start bleeds and the compressor bypass bleeds are open at engine start. During low power operation the start bleeds are scheduled to close as a function of engine rotor speed, and controlled by the pressure rise across the main fuel pump. The compressor bypass bleeds are scheduled (at low power) by the main fuel control as a function of engine speed biased by engine inlet temperature. At aircraft approach power settings the start bleeds may be either open or closed. The bypass bleeds are normally open.

k. Engine accessories except the afterburner turbopump and afterburner control are mounted on and driven by the engine main gearbox. The afterburner pump is driven by compressor bleed air. Airframe accessories are located on a remote gearbox driven from the engine power take-off pad.

l. The installed engines had the following sea level static standard day average thrust rating:

Maximum Afterburning - 31,500 lbs.

This rating is not time limited.

2. Investigation:

a. Aircraft 133/939 was equipped with the following engines:

ENGINES:

<u>POSITION</u>	<u>TYPE</u>	<u>SERIAL NO.</u>	<u>TOTAL FLIGHT TIME</u>	<u>FLIGHT TIME SINCE OVERHAUL</u>
1.(LH)	YJT11D-20A	P648222	25:17	N/A
2.(RH)	YJT11D-20A	P648234	19:40	07:30

b. History of Engines:

(1) Engine P648222

**OXGART**

2

**SECRET**



~~SECRET~~

(a) The subject engine was manufactured by Pratt & Whitney Aircraft during the month of June, 1963.

(b) The engine was installed in the Nbr. 1 position of Article 133/939 on 26 June 1964.

(c) Last flight - 9 July 1964:

Total Time	80:23
Total Flight Time	27:17
Total Ground Time	55:06
Military Power & Above	24:32
Afterburner Time	16:57
Above Mach 2	06:57
Above Mach 3	00:00

Engine P-648222 Installation Summary

<u>ARTICLE NUMBER</u>	<u>POSITION</u>	<u>NBR. FLTS.</u>	<u>INSTALLED</u>	<u>REMOVED</u>	<u>ACCUMULATED FLIGHT</u>	
					<u>TIME</u>	<u>SQUAWKS</u>
122/925	RH	1	15/7/63	20/7/63	00:41	None
121/924	RH	1	08/6/63	14/8/63	00:49	A/B Liner Failure
121/924	LH	1	08/9/63	13/9/63	00:39	Bent Enc Rod
129/932	LH	21	26/9/63	19/12/63	18:12	None
1003/936	LH	1	04/4/64	15/5/64	01:31	None
129/932	LH	1	17/6/64	24/6/64	00:56	Honeycomb Failure
133/939	LH	3	26/6/64	-	02:29	None

(2) Engine P648234

(a) The subject engine was manufactured during the month of August 1963 by Pratt & Whitney Aircraft.

(b) The engine was installed in the Nbr. 2 position of Article 133/939 on 13 June 1964.

~~OX~~CART

~~SECRET~~

(c) Last flight - 9 July 1964:

	<u>TOTAL TIME</u>	<u>TIME SINCE OVERHAUL</u>
Total Time	40:47	18:04
Flight Time	19:40	07:30
Ground Time	21:07	10:34
Military Power & Above	17:02	07:37
Afterburner	12:45	06:02
Above Mach 2	04:51	02:26
Above Mach 3	00:00	00:00

Engine P-648234 Installation Summary

<u>ARTICLE NUMBER</u>	<u>POSITION</u>	<u>NBR FLTS</u>	<u>INSTALLED</u>	<u>REMOVED</u>	<u>ACCUMULATED FLIGHT</u>	
					<u>TIME</u>	<u>SQUAWKS</u>
125/928	RH	9	09/963	14/10/63	09:23	A/B Liner Failure
125/928	RH	3	15/10/63	24/10/63	02:47	Tower Shaft Gear Failure
133/939	RH	2	27/5/64	6/6/64	01:58	None
133/939	RH	7	13/6/64	-	05:32	None

3. Description of Damage: (accessories and components are covered in item 4)

(a) L/H engine P-648222 - This engine was extensively broken up. The majority of the engine was recovered in the following segments:

- (1) A/B birdcage and nozzle assembly. (Photo #4770)
- (2) Turbine exhaust case, A/B diffuser duct, part of nbr. 3 hub, and A/B nozzle actuators. (Photo #4767)
- (3) Turbine assy, with turbine nozzle case, all vanes, and blades, part of nbr. 3 hub, both discs and part of the turbine shaft. (Photos #4748 and 4763)
- (4) Turbine shaft (twisted and broken). (Photo #4751)
- (5) Nbr. 2 hub with 8th and 9th compressor discs. (Photo #4744)
- (6) Major portions of 1st, 2nd, 3rd, 4th, 5th, 6th, and 7th compressor discs. (Photo #4794)

SECRET

SECRET

(7) Parts of nbr. 1 hub and bearing. (Photos #4735 and 4736)

(8) Compressor vane and case assemblies were found completely broken up. Recognizable portions of the case assemblies were recovered but relatively few compressor vanes and blades were found.

(b) R/H engine P-648234 - This engine was even more extensively broken up than the left hand engine. As shown below the compressor parts were comparable to those of the left engine but the turbine and A/B sections were much more extensively damaged. Important items found include:

(1) A/B nozzle actuators. (Photo #4795)

(2) Turbine discs and nbr. 3 hub. (only blade roots remained). (Photo #4780)

(3) Turbine casing (approximately 40% of total). (Photos #4768 and 4769)

(4) Turbine shaft and nbr. 2 bearing assembly. (Photo #4755)

(5) Major portions of 1st, 2nd, 3rd, 4th, 5th, 7th, 8th, and 9th compressor discs. (Photo #4794)

(6) Fractions of the rim of 6th compressor disc.

(7) Parts of nbr. 1 hub and bearing. (Photos #4735 and 4736)

(8) Compressor vane and case assemblies were found completely broken up. Recognizable portions of the case assemblies were found. The recognizable portions of the case assemblies could not be identified sufficiently to establish from which engine they came.

(c) Identification of major parts including components established that the L/H engine broke up along a divergent path to the east of the crash track. The R/H engine broke up along a path only slightly divergent west of the crash track. Compressor parts were found in the initial impact area. Progressing north in the general directions of all wreckage the engine parts were found in generally predictable order: compressor discs, burner cans, fuel system components, A/B section parts. Turbine section parts, A/B fuel controls and some of the compressor discs over-travelled the general wreckage and were found up to 2,400 feet from the point of impact. Ground impressions indicated these disc and turbine assemblies travelled these distances as a result of their high rotational energy at the time of the separation from the complete engine assembly. (Photos # 4683, 4520, and 4522)

~~SECRET~~

5 SECRET

~~SECRET~~

(1) The 3 main bearings of both engines were inspected and found in good condition except for impact damage. The engine oil filters were satisfactory. Those main bearing seals recovered were damaged only by impact.

(2) Detailed inspection of the engine parts revealed no abnormalities prior to impact. There was no evidence of fire prior to impact or after impact on any parts except the few located in the area of the ground fire. All fuel and hydraulic filters were normal.

4. Engine Accessories and Components. All of the major components of both engines were recovered. Investigative teardown was performed on all components pertinent to the investigation.

(a) Main Fuel Control - The engine is equipped with a JFC-47 fuel control which meters main engine fuel flow, controls the bleed bypass valves and establishes engine rotor speed by exhaust nozzle area modulation. Control inputs are power lever position, inlet air temperature, and pressure. engine burner pressure and engine speed. Bypass bleed position is controlled as a function of engine speed biased by inlet air temperature. Both main fuel controls were recovered although some protrudances were broken off of each. Both units were partially torn down for investigation.

(b) L/H Engine S/N 222, Main Fuel Control S/N 33258

(1) Both main and servo filters were free (minor amount of dirt).

(2) Power lever at idle (A/B control from this engine at max A/B PLA).

(3) TT2 servo was in full cold position. TT2 bulb capillary tube was severed. The control must have had servo pressure to drive TT2 servo cold when the capillary tube was severed or impact drove it to the cold direction. The TT2 servo was free (can be pushed normally), and is not spring loaded.

(4) The intergrating piston was in A/B nozzle open position and damaged. This is the normal position for this piston on loss of fuel pressure. The transducer valve (Exhaust Nozzle Area) was free and in the nozzle open position (normal position for loss of fuel pressure). (Note - Any references to loss of fuel pressure refer to after impact.)

(5) The metering valve was free and at min flow position, the normal position for loss in fuel pressure due to being spring loaded. The metering valve feedback spring was connected and at min flow position.

(6) The speed drive was OK and all pilot valves free and turning.

OX CART

6 SECRET

(7) The speed servo was at 5,300 engine RPM position. This servo is vertical when engine horizontal. On loss of fuel pressure this servo would start to go in decrease speed direction until pressure was too low to move it.

(8) Pressure Regulating Valve (PRV) sensor pilot valve and PRV were both free.

(9) Compressor Bleed Actuator (CBA) servo free and loaded against cam (normal due to spring load) in bleeds open position which would be normal for TT2 servo to be at full cold position (failsafe). CBA power piston was separated from control. The shaft to C.B. pilot valve was wrapped around housing in bleeds open position. The CBA power piston was at full travel in the bleeds open position, (direction of shaft wrap).

(c) R/H engine (Control data plate missing, engine records indicate S/N 26648)

(1) Both main and servo filters free (minor amount of dirt).

(2) The power lever was at idle when examined Monday noon, 7/13 and is known to have been moved since. Movement if any between crash and noon of 7/13 is unknown. (A/B control PLA at shut off or few degrees below shut off). Stop area damaged and missing indicating position affected by impact.

(3) The TT2 servo was in approximately 70 to 85° F position and could be moved freely.

(4) The integrating piston was in nozzle modulating position and jammed due to housing damage. The transducer valve was free and in modulating position.

(5) The main metering valve was in full open position and metering valve feedback spring in full open position. The metering valve multiplying lever pilot flexures (pivot retention) sheared probably from impact. In this condition it cannot be predicted where the metering valve would go. There was extensive housing damage in metering valve area which probably jammed the metering valve. When metering valve and sleeve were removed from the housing, it was free in bore and feedback spring would move the valve to min flow position.

(6) The speed drive was OK and all pilot valves free and turning.

(7) The speed servo was at approximately 6,800 RPM position. Speed servo was free in its bore.

(8) PRV sensor pilot valve was free. PRV missing.

OXGART

7  
SECRET

(9) CBA servo was free and loaded against cam (normal due to spring load) in the bleeds closed position. This is normal for TT2 servo position. CBA power piston was separated from the control and was in full bleed closed position and moves freely.

(d) Main Fuel Pump - The main fuel pump (MFP) is a two stage pump consisting of a single centrifugal boost stage and a dual element gear stage. Maximum discharge pressure is approximately 900 psia.

(1) The left hand engine was equipped with MFP S/N 2005; the right hand engine was equipped with S/N 2016. Both were recovered largely intact. The pump filters were inspected and found to be in normal condition. Axial end play of both pumps was found to be in limits. Both units were free to turn and showed no signs of pump distress.

(e) Afterburner Fuel Pump - An air turbine driven single stage centrifugal pump is used. Pump discharge pressure is controlled by the A/B fuel control which regulates the flow of compressor bleed air to the pump drive turbine.

(1) The L/H engine was equipped with S/N 70960; the R/H engine had S/N 67935. Both units were recovered. No teardown was done since the engines were operating non A/B at the time of the crash.

(f) Afterburner Fuel Control - The JFC-51 A/B fuel control meters fuel flow to the afterburner and schedules compressor bleed air to the A/B fuel pump. Fuel flow is scheduled as a function of power lever angle, engine burner pressure and inlet air temp. The control, incorporates a reset mechanism which reschedules fuel flow as a function of compressor bypass bleed position.

(1) The left hand engine was equipped with S/N 33279, the R/H engine with S/N 33274. Both were recovered essentially intact. Since the engines were operating non A/B at the time of the crash, tear down was not performed except to determine the power lever angle (PLA) at impact. The power lever of S/N 33279 was at the max A/B position; on S/N 33274 the PLA was at or below shutoff. Neither reading is considered indicative of PLA at the time of impact.

(g) Hydraulic Pump - A variable delivery engine-mounted high-temperature pump provides up to 3,000 psig for actuation of start and bypass bleed systems and the exhaust nozzle.

(1) The L/H engine was equipped with S/N JX 232588, the R/H with S/N JX 231414. Both units were recovered largely intact. They were not torn down because inspection of fuel system filters including the hydraulic filters (2 separate units per engine) showed no abnormalities.

OXGART

8 SECRET

~~SECRET~~

(h) Exhaust Nozzle Control - This is an aft mounted component of the main fuel control engine speed sense system. It also functions as the servo control system for the A/B nozzle actuators. The left hand engine was equipped with S/N 33136; and R/H engine with S/N 33305. Both units were recovered. All internal parts were found free and in working condition. In both units the main pilot valve was ported to the nozzle open position. This is the normal spring loaded position with no fuel pressure, and therefore not indicative of its position prior to impact.

(i) Chemical Ignition System Unit - This is a combined tank and control unit (engine mounted) which introduces a measured quantity of triethylborane (TEB) into either the main burner or the afterburner in response to initiation of pressure (flow) in fuel manifold. This is accomplished automatically by power lever movement and sequential pressurization of either fuel manifold. Reducing fuel pressure to zero in either manifold (by power lever action) recycles the change cylinder for firing. Fully serviced the CIS tank holds 600 cc of TEB under a nitrogen pressure of 650 Psi. A pilot controlled emergency dump system actuated by hydraulic pressure will empty this system into the engine tailpipe in a few seconds.

(1) The left hand engine was equipped with S/N 33394; the R/H with W/N 33109. Both units were recovered in battered condition. To preclude possible injury to personnel from any remaining TEB the units received special handling and were opened by gunfire to allow any remaining TEB to burn. It was found that the TEB and nitrogen had escaped from S/N 33394 at the time of impact. In S/N 33109 the nitrogen had escaped at impact but the TEB remained. The unit burned for over one half hour after piercing by gunfire.

(2) Since neither airstart nor A/B light was a factor in the crash, no attempt was made to investigate these units.

(j) Start Bleed Pilot Valve - This valve ports fuel to the start bleed actuators on the basis of main fuel pump pressure rise. Both units were recovered and torn down and both were found in the bleeds open position.

(1) S/N YA 118 (R/H engine) was found in working order and in the normal spring loaded position when no fuel pressure exists.

(2) S/N 8223 (L/H engine) was found jammed by impact damage which presumably occurred after loss of fuel pressure.

(k) Compressor Bleed Pilot Valve - Ports hi pressure fuel to the by-pass bleed actuators in response to input from the main fuel control. This unit mounts on the main fuel control.

OXGAR

SECRET

**SECRET**

(1) Neither unit was recovered. Indications of CBPV position at impact were obtained from the main fuel control CBA servo (see page 6) and the compressor bleed actuator (para 1 below).

(1) Compressor Bleed Actuators - Four of these units are used to actuate the bypass bleed; three are used to actuate the start bleeds. Total travel of these two position actuators is approximately two inches.

(1) L/H Engine S/N 222. Engine records indicate the four (4) by-pass bleed actuator S/N's as 8222-1, -2, -3, and -4. These actuators extend to close the internal bleed doors. They are normally full open or closed.

8222-1 Not recovered

8222-2 Approximately 0.540" from full extension. Shaft bent approximately 120° approximately 3/4" from gland nut.

8222-3 Within 0.003 of full extension. Shaft bent approximately 25° at gland nut.

8222-4 Approximately .760 - .776 from full extension shaft bent approximately 10° at gland nut. Housing severely dented just below piston on shaft side of piston.

The 8222-3 actuator had part of the CBA reset cable attached indicating it was installed at the 2 O'clock position. Installed position of the others is unknown.

Engine records indicate the 3 start bleed actuator S/N's as 8222-5, -6, and -7. These actuators retract to close the external bleed doors.

8222-5 Within .002 of full retraction

-6 Not recovered

-7 Not recovered

(2) R/H Engine. Engine records indicate the four (4) by-pass bleed actuator S/N's as 8234-1, -3, -4, and -5. These actuators extend to close the internal bleed doors.

8234-1 Cover gone. Housing sheared at cover flange. Piston sticking out of housing (sheared end) approximately 0.3" beyond full retraction.

-3 Approximately 0.000" from full extended shaft bent approximately 11° at gland nut.

-(?) Cannot read S/N. Assumed to be -5 since part of CBA reset cable attached indicates this as 2 O'clock by-pass actuator. Within .007 of full extension.

**OXGART**

**SECRET**



Shaft bent less than 5° at gland nut.

Engine records indicate the 3 start bleed actuator S/N's as 8234-2, -7, and 60028. These actuators retract to close the external bleed doors.

8234-2 Within .003 of full retraction

-7 Not recovered

60028 Within .025 of full retraction

(m) A/B Nozzle Actuators - All (four per engine) were recovered and torn down to obtain indications of exhaust nozzle positions at impact.

(1) Of the left hand engine actuators, 3 were at an extension of 8-15/32 inches while the fourth was 8-5/16 inches. This is remarkable close agreement and corresponds to a nearly full closed nozzle.

(2) The R/H engine actuators were at extensions of 3.344, 3.563, 4.360, and 4.719 inches respectively. The average of these values corresponds to an intermediate nozzle position. It is probable that these actuators reached their final positions from inertial loads at impact.

5. Analysis: The pilot stated that the engines were set at low power as he decelerated on final approach. He also stated that he could make the runway with the power on at the onset of the aircraft roll. He had a definite recollection of the right engine start bleed light being illuminated which is a normal indication of low (but proper) RPM and thrust.

(a) Data from comparable approach condition of Article 122, flight #66 (7/8/64) the following power settings were taken from the flight records:

Time:	1:20:34		
Alt.	4,500 feet		
MN	.34		
KEAS	201		
PLA	$\frac{L}{19}$	$\frac{R}{32}$	Deg.
Total Fuel Flow	3,600	5,500	PPH
EGT	325	367	Deg. C
RPM	4,750	5,810	
ENPI	76	85	% full open

OX CART

11 SECRET

b. For this condition the left engine start bleed light would probably be "ON" while the right hand engine start bleed light would be "OFF". Acceptable limits for this function are 4,500 to 5,100 RPM.

c. The pilot further stated that when the roll started he began to add power slowly with the intention of going around. He definitely felt power increase when he asked for it but he did not know how much he asked for nor how much he got because the control stick hit the stop and he ejected at this time.

d. In answer to a direct question whether an engine out could have caused the roll the pilot stated that he did not think so because there was no yaw which is always present with the engine out condition.

e. Both cockpit EGT gauges were recovered from the wreckage. EGT readings of 668 deg. C. and 705 deg. C. were obtained from the two instruments. (Photo of gauges.) Using these EGT values, the pilot and witness reports of altitude and airspeed, and record air temperatures at the time of impact, performance engineers at CRDC calculated the following engine parameters at the time of impact:

Engine Position	RH	LH
EGT	668	705
% Mil Thrust	76	82
Thrust	11,525	12,480 lbs.
PLA	53	55 deg.
RPM	6,855	6,855
Nozzle Area	6.28	5.96
Engine Fuel Flow	14,035	14,990 PPH

Note that PLA's given here are degrees at the engine fuel control. The aircraft system provides a 2 to 1 ratio so cockpit power lever angles are half those given.

f. The values above show that both engines had accelerated to military scheduled RPM and approximately 80% military thrust at the time of impact. No RPM or fuel flow values were obtainable from the cockpit instruments. One cockpit ENPI yielded a reading of full open but this is not consistent with any other information obtained. One ENPI transducer was jammed at approximately 20% from nozzle closed to open position. The other transducer was not located. This valve is very close to calculated nozzle position (based on EGT).

OXCART

12

SECRET

g. The nozzle position obtained from the left engine A/B actuators agrees very closely with the value calculated from EGT and further substantiates the acceleration of the engines.

h. The spread of engine wreckage far beyond the aircraft wreckage also indicates high rotational speed at impact. Among the parts found further from the point of impact were both turbines and some of the aft compressor discs.

i. Tabulation of the engine start and by-pass bleed actuator positions also generally confirms the fact that the engine bleeds were closed at the time of impact, indicating the engine RPM had increased as demanded by the pilot. The compressor bleed actuator linkage (in main fuel control) of the RH engine also confirms the bleeds closed (high RPM) setting.

j. The remarkable similarity of damage to the two compressors indicates comparable rotational speeds of the two engines. The difference in damage to the turbine and A/B sections of the two engines is attributed to one engine totally impacting while the other tumbled on otherwise suffered less severe initial impact.

**OX CART**

13

**SECRET**

B. Engine Air Inlet System

1. The air inlet system functioned normally throughout the flight except for a "popped" shock condition on the left hand inlet during a high speed run as reported by the pilot. The shock was recaptured and the flight continued.

2. The landing approach was evidently normal relative to the inlet system, with the inlet bypass in the open position. The secondary bypass was closed and the spikes were full extended. The spike full extended positions were determined by the break-off of the actuator full extended piston rods at the forward end of the actuator cylinders. The right hand spike actuator cylinder broke in two, trapping the piston in the forward broken off section. (Photo #4677). The left hand spike actuator remained intact except for the previously mentioned breaking of the piston rod in the full extended position.

3. The left hand inlet partial structure remains indicate that the bypass was in the normal open position. (Photo #4664). The right hand inlet was so extensively damaged that it is not possible to determine that it was open or closed. (Photo #4663). Normally the landing gear extension will open the bypass by the landing gear actuated switch. Both secondary bypasses were damaged to a point that it is not possible to determine if they were actually closed. Normally they are manually closed before a landing is attempted in order to prevent foreign object damage to the engine when reverse air flow occurs due to the lack of ram condition in the inlet on the ground. The possibility of these being open would not cause any appreciable engine power loss during a landing.

4. In summing up the inlet system it appears that the system was functioning in a proper manner and did not contribute in any way to the loss of control of the subject airplane.

**OXGART**

14 **SECRET**

## C. Fuel System Description (See figure 2-1)

1. The fuel supply is carried in six internal tanks that are integrally sealed and use most of the fuselage volume and a portion of the wing volume. All tanks are connected together with a common vent system, refueling system and a manifold feed system to the left and right hand engines.

## (a) Tank system capacities:

The measured tank capacities are as follows:

<u>TANK NO.</u>	<u>GALLONS</u>	<u>POUNDS</u>
1	1,110	7,215
2	1,595	10,367
3	1,572	10,218
4	2,130	13,845
5	2,142	13,923
6	<u>1,973</u>	<u>12,838</u>
TOTAL	10,524	68,406

## (b) Refueling system: (See figure 2-2)

All refueling is accomplished through an inflight refueling receptacle located on the forward top side of the fuselage at F.S. 475. Ground refueling is accomplished through this same receptacle. To the receptacle aft end and inside the fuselage is connected a refueling manifold running through all fuselage tanks. This manifold is not required for filling wing tanks as each wing opposite fuselage tanks 4, 5, and 6 are connected by fill and drain holes in the fuselage skin where the wing passes through the fuselage. In each tank a branch line of the fueling manifold is installed and a dual shutoff valve which is operated by a dual float valve near the top to the tank. When the fuel is at the float level this automatically shuts off the shutoff valve, thus preventing overfilling the tanks. A ground check is made possible by plugging in test box AG 128 in the nose wheel well to test each half of the dual shut off valve to see that is operating properly before flight. Each tank shutoff valve is sized with an orifice so that the filling rate is the same for each tank to maintain proper center of gravity.

(c) Fuel Feed System: (See figure 2-3)

There are two fuel feed manifolds running through the fuselage and out through the main wheel well to the right and left hand engines. The left engine is fed by the left hand manifold from tanks #'s 1, 2, 3, and 4; and the RH engine by RH manifold and tanks #'s 1, 3, 5, and 6. In the main wheel well the right and left manifold are connected with a gate valve so that if necessary either engine may be fed by both or either manifold when this gate valve is open.

(1) Fuel usage sequence keeps the C.G. within the desired limits of travel. An aft C.G. for high speed and a forward C.G. for low speed, take-offs and landings. A forward transfer is provided from the right manifold, making it possible to transfer fuel into tank #1 from #'s 3, 4, 5, and 6 before landing, thus moving the C.G. forward.

(2) The normal usage sequence is:

<u>L.H. ENGINE</u>	<u>R. H. ENGINE</u>
# 1 and # 2	#1 and #6
# 2	#6
# 4	#5
# 3 or # 1 and # 3	#3 or #1 and #3

(d) Defueling System:

(1) A defueling valve is provided in the lower right side of the fuselage of tank # 4 and is connected to the right feed system manifold. To defuel tanks # 2 and # 4 it is necessary to open the crossfeed valve.

(e) Fuel Dumping System: (see figure 2-3)

(1) There are two dual electrically operated dump valves connected to each of the two fuel feed lines. Aft of the dump valves the dump lines are connected in the tail cone by which the fuel is dumped overboard. The dump valves are so designed that while dumping the pressure in the fuel feed lines does not drop below 10 PSI, thus maintaining enough pressure to feed out to the engines.

(f) Fuel Tank Venting System: (See figure 2-4)

(1) A common vent line runs through all tanks and into the tail cone where the vent line branches into two lines. At this location are two vent valves, a primary valve which is set to maintain a tank pressure of 1.5 PSIG, and crack open at a pressure differential of 3.0 PSIG, with a maximum gaseous flow of 30 lbs. per minute. This valve is also capable of a liquid flow of 200 GPM

OXCART

16

SECRET

at a pressure of 4 PSIG should fuel be forced into the vent line due to overflowing of tanks during refueling. The secondary vent valve relieves at 3-1/2 PSIG should the primary valve fail to operate.

(2) In each tank at the aft end of the tank connected to the vent line is a float shutoff valve to prevent fuel from flowing into the vent line. At the front of each tank is a float shutoff and relief valve which will relieve at 1.5 PSI so that during fueling operation should the tank be overfilled the fuel will be allowed to go into the vent and prevent damage to the fuselage tanks.

(3) Connected to the vent line in tank #1 is a suction relief line and valve. This line is open ended to ambient pressure and the valve operates automatically on emergency, (such as 0.0 PSI tank pressure and no LN2 on board). Thus preventing damage to the tanks due to negative pressure.

(g) Fuel Description:

(1) The fuel used is designated as PWA523C and has the following characteristics at sea level pressure (14.7 PSI.):

VAPOR PRESSURE	2.7 PSIG 1300° F
FLASH POINT	150 deg. F Minimum
INITIAL BOIL POINT	375 deg. F Minimum
FREEZE POINT	-40 deg. F Maximum
LUMINOMETER NUMBER	100 Minimum
VISCOSITY AT -30 deg. F	15 Cs Maximum
GRAVITY, DEGREES API	47 to 53
SPECIFIC GRAVITY	.767 to .793 60 deg./60 deg. F.
HEAT OF COMBUSTION	18,900 BYU/16

2. Summary:

a. Fuel feed system and boost pumps preflight checked out and operating properly. LN2 system filled to between 60 and 75 liters in each dewar. Press to test valve operated on LN2 system, system functioned normally.

b. Fuel loading condition prior to flight as follows:

<u>TANK NO.</u>	<u>FUEL QUANTITY</u>
# 1	6,100 lbs

SECRET 17 SECRET

# 2	5,800 lbs
# 3	10,100 lbs
# 4	12,500 lbs
# 5	12,400 lbs
# 6	11,050 lbs

This loading gave C.G. of about 21.4%.

c. Approximate fuel used during taxi and takeoff follows:

600 lbs from tank # 1  
300 lbs from tank # 2  
800 lbs from tank # 3  
300 lbs from tank # 6

d. Aircraft fuel management during flight:

<u>L.H. ENGINE</u>	<u>R.H. ENGINE</u>
# 1 and # 2	# 1 and # 6
# 2	# 6
# 4	# 6
# 4	# 5
# 3	# 3 and # 5
# 1 and # 3	# 1 and # 3

e. Fuel System Condition at Time of Accident:

On let-down and approach tanks 4, 5 and 6 were empty. 4,000 lbs were transferred into tank # 1 and about 3000 to 4,000 lbs remained in tank # 3. Fuel was then feeding from tanks #1 and # 3 to right and left engines. This loading condition on approach would put the C.G. approximately at 21.5%.

f. Pilot Report of Operation of Fuel System:

Fuel systems operated normally and he did not override automatic fuel management sequence.



g. Unsymmetrical Loading:

As most of the fuel is carried in the fuselage with a small amount in the inboard wings it is impossible to get out of balance in a lateral condition and cause a roll of the aircraft in a low fuel quantity condition.

OXGART

SECRET

**D. Pressurization and Inerting System****1. Fuel Inerting System Description: (See figure 2-5)**

a. The inerting system components are located in the nose wheel well. The system is so designed that it has dual reliability. Two separate systems operate such that if one system fails the components of the other system will take over.

b. Each system consists of 75 liter liquid nitrogen dewar, fill and vent valve, demand regulator, orifice flow indicator, press-to-test valve and a panel assembly.

c. The function of the inerting system is to maintain a positive pressure of 1.5 PSIG inside the fuel tank and also to inert the fuel tanks; preventing the possibility of a combustible mixture in the hot fuel tanks.

**2. Pressurization and Inerting System Operation:**

a. The system is so designed that it will maintain a tank pressure of 1.5 PSIG. If the pressure drops below this then the sensing chamber on the regulator senses the low tank pressure, thus allowing the regulator to open and allow a flow of LN2 into the heat exchangers in tanks #1 and #3 and then into the vent line of the aircraft. At this time the nitrogen is gaseous and is allowed to pass into all of the tanks through the vent system of the aircraft.

**3. System Safety Factors:**

a. Dual system.

b. Continuous LN2 quantity display.

c. Dual vent valves in aircraft venting system. This allows for a runaway LN2 regulator, thus the vent system of the aircraft can handle the large flow of gaseous nitrogen and not damage the full tanks, due to over-pressurizing.

**4. Descent Rate Capabilities:**

a. From mockup tests of the pressurization and inerting system it was determined that one N2 regulator (or system) was capable of maintaining a fuselage tank pressure 1.5 PSIG. at an aircraft descent rate of 12,000 feet per minute.

**5. Summary:**

a. LN2 Loading Before Flight:

~~OX CART SECRET~~

(1) From flight test engineers log it was determined that between 60 and 75 liters was aboard each dewar before flight; and that the press-to-test valve was operated on each system to see that LN2 was flowing to tanks.

b. LN2 Loading at Crash: (See Photo #4686)

(1) At time of crash LN2 indicators read 12 liters on one dewar and 58 liters in the other dewar.

c. Descent Rate of Flight:

(1) From an altitude of 78,000 feet to 28,000 feet elapsed time was approximately 16 minutes thus giving a descent rate of about 3,600 feet per minute. From 28,000 feet to 12,000 feet elapsed time was approximately 3 minutes, thus giving a descent rate of 5,300 feet per minute.

(2) As the descent rate of the flight in both cases was far below the tested descent rate of 12,000 feet per minute and the fact that LN2 was flowing through the regulators into the tanks, it would indicate that the system was functioning properly.

d. Test Results of LN2 Regulators:

Both regulators were removed from the aircraft remains and functionally tested. Results show that both regulators are still functional. One regulator completely passed the normal production functional test. The other regulator had a broken spring due to impact but its diaphragm functioned properly.

~~OX CART~~

21 ~~SECRET~~

**E. Findings**

1. There was no internal or external fire damage to either engine except to a small number of parts exposed to ground fire after impact.
2. The engine lubrication system, bearings, and seals were free of distress prior to impact.
3. The engines responded to the pilot demand for power prior to ejection and had accelerated from low power to max scheduled RPM and approximately 80% military thrust before impact.
4. The engine and aircraft records show that both engines were in serviceable condition prior to the last flight.
5. The engines were not a factor in the accident.
6. The engine inlets were not a factor in the accident.
7. The aircraft fuel system was not a factor in the accident.

**F. Recommendations:**

1. None

**OXCAT SECRET**

25X1A Approved For Release 2001/08/29 : CIA-RDP71B00590R000100040001-1



Propulsion Engineer  
Directorate Aerospace Safety



ADP Fuel System Engineer  
Lockheed Aircraft Corp.

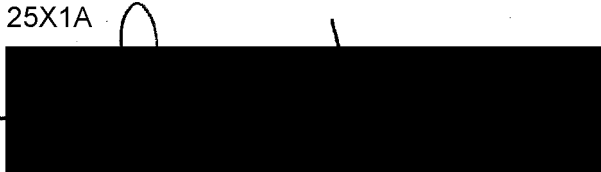

Lockheed Aircraft Corp.



Sr. Project Engineer  
Pratt & Whitney Research and Development Center  
West Palm Beach, Florida

**OXCAT SECRET**

Approved For Release 2001/08/29 : CIA-RDP71B00590R000100040001-1

**OXGART SECRET**

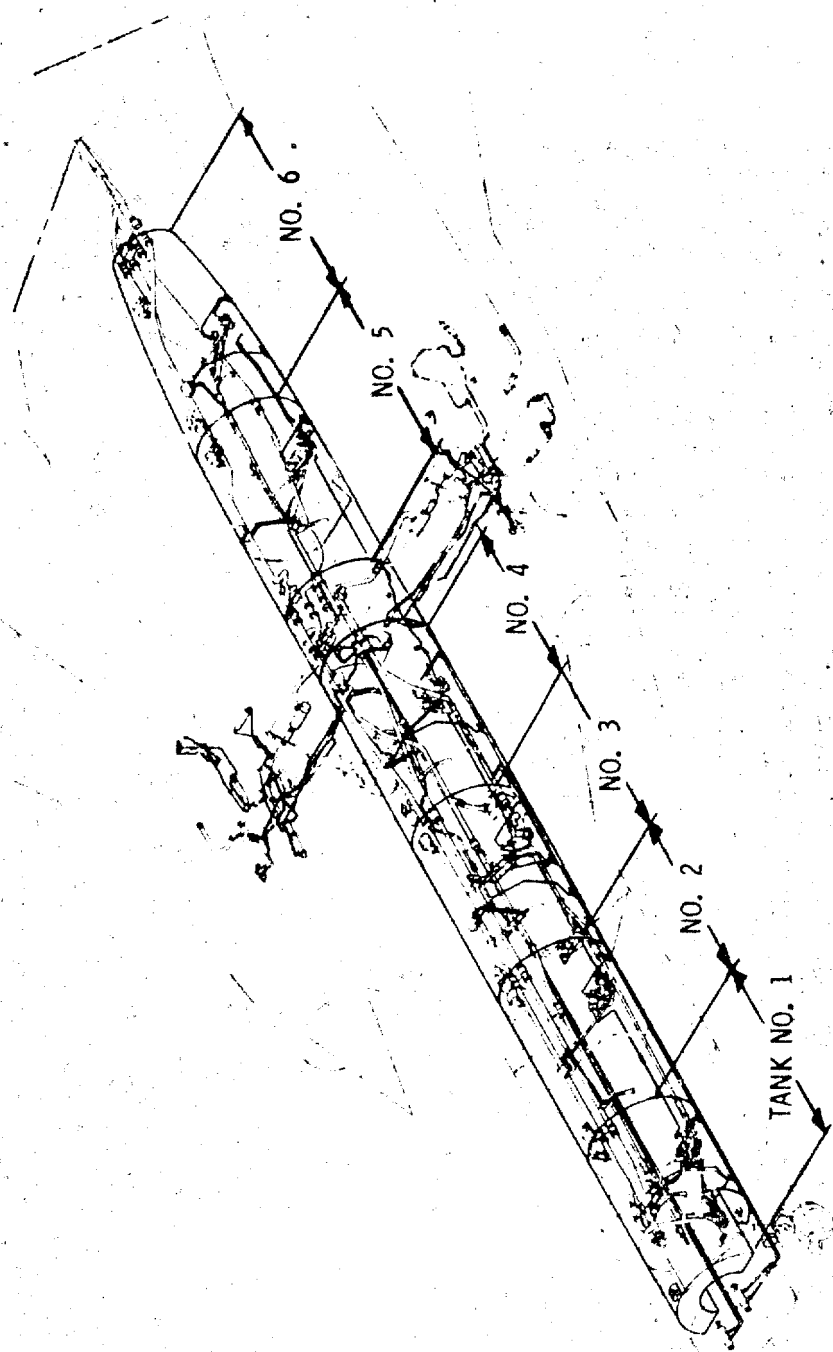

Figure 2-1. Fuel System Isometric.

**OXGART SECRET**

**OX CART SECRET**

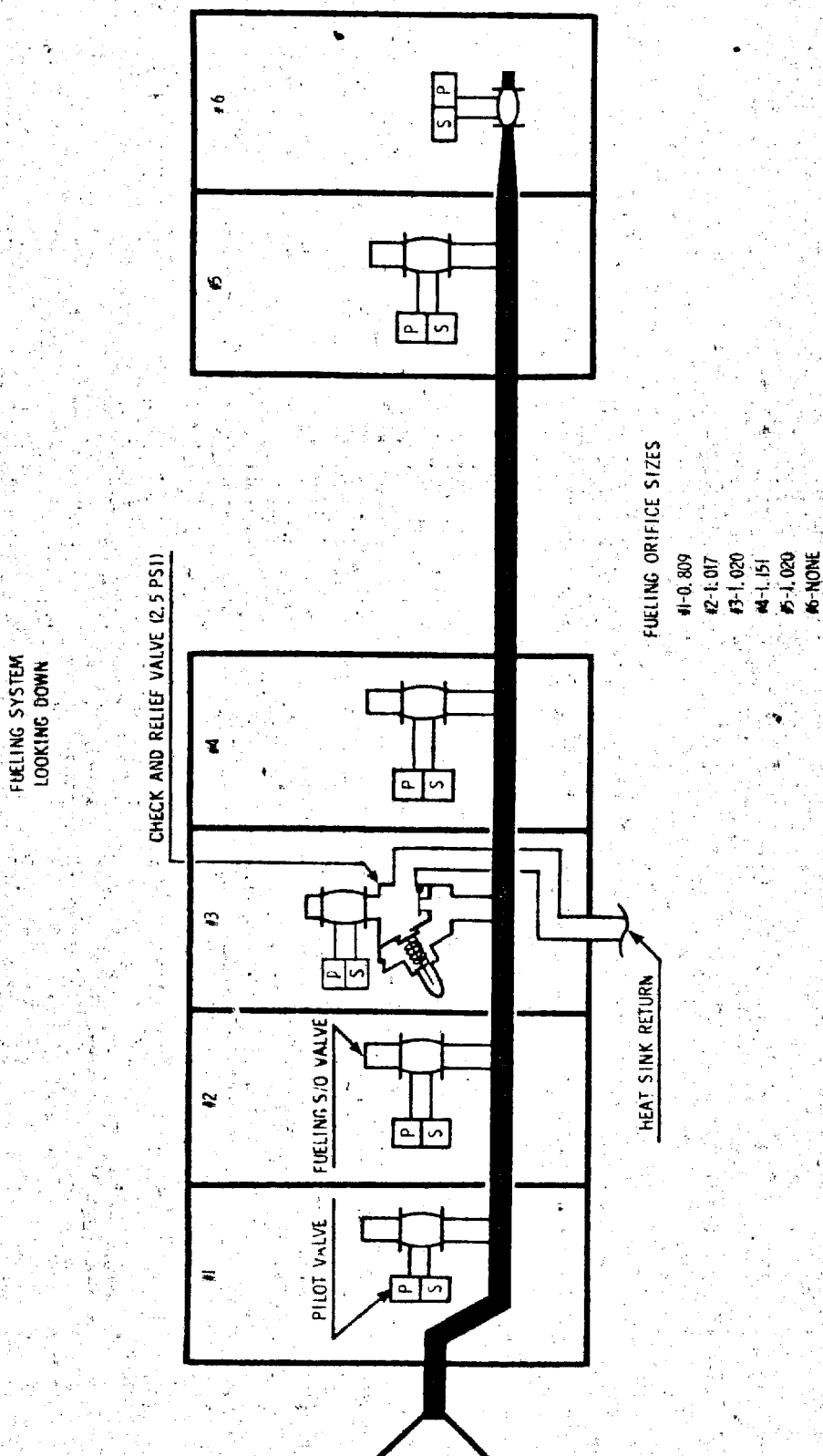

Figure 2-2. Fueling System

**OX CART SECRET**

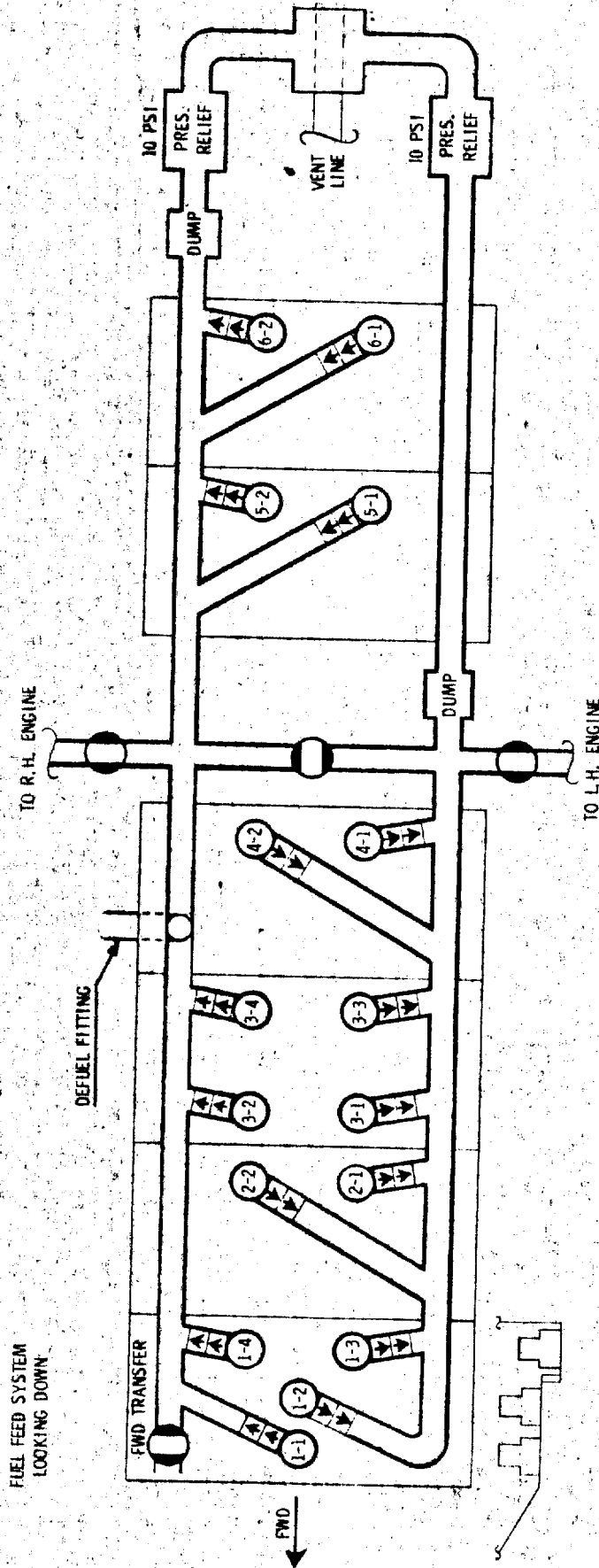

Figure 2-3. Fuel Feed System



OXGART SECRET

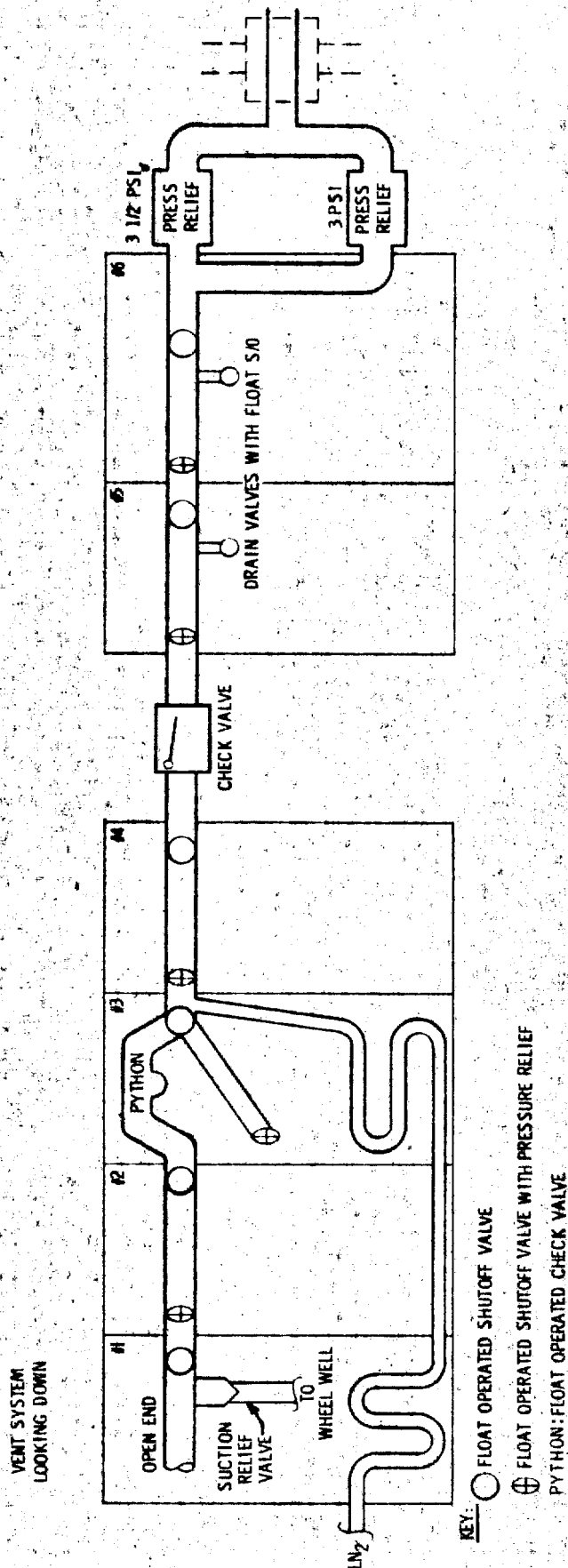

Figure 2-4. Vent System

OXGART SECRET

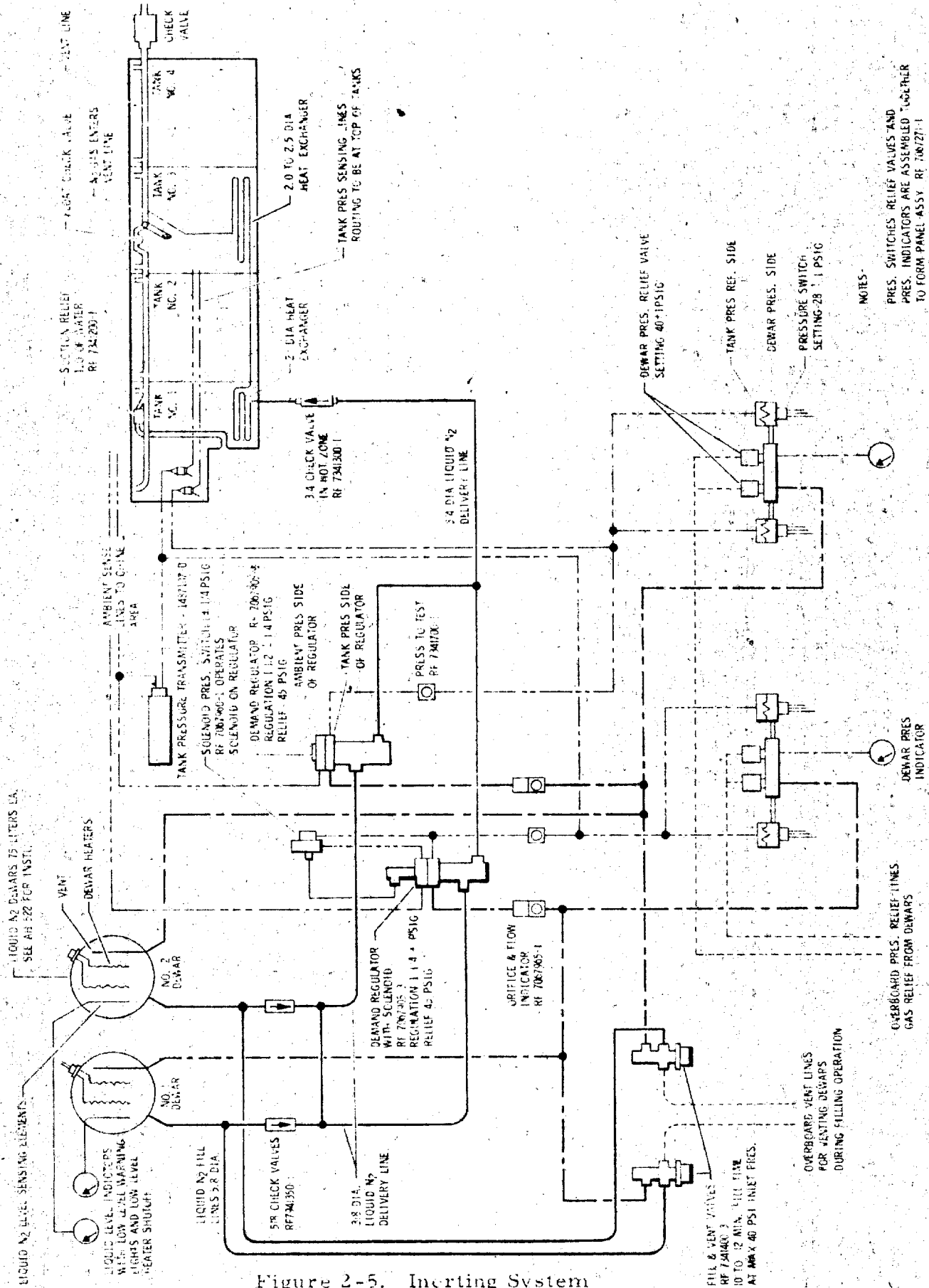

Figure 2-5. Inerting System

ELECTRONICS

AND

ELECTRICAL

GROUP

**OXBART SECRET**

ELECTRICAL, ELECTRONIC AND INSTRUMENT GROUP

Investigation of Major Accident Involving A-12 Aircraft, S/N 133, which Occurred at Detachment 1, 1129th USAF SAS, Las Vegas, Nevada, on 9 July 1964.

A. ELECTRICAL SYSTEM

1. System Description.

a. The airplane was equipped with two engine-driven AC generators, the output of which is variable frequency, 3-phase current. Each generator is rated at 30 KVA. Each generator powers the left and right busses respectively. A means is provided to open the contactor for a failed generator and to close a bus-tie contactor. In this configuration, one generator supplies the entire variable frequency AC load. One generator is capable of providing the entire essential load for an indefinite period. The left generator furnishes power to eight fuel booster pumps, left engine fuel shutoff valve, fuel cross-feed valve, HF communication power, UHF blower, left EGT control power, inertial navigation system (INS), Nr. 1 nitrogen heaters, left transformer-rectifier (T-R) and special electronic equipment. The right generator furnishes power to eight fuel booster pumps (total 16), right engine fuel shutoff valve, Q-bay equipment, Nr. 2 nitrogen heaters, right EGT control power, right T-R and the trim actuator transformer. The latter provides 3-phase, 26 volts AC power for the following trim actuators: manual pitch, automatic pitch, yaw and roll. The left generator also provides single phase power for additional loads. The A-phase powers the air sampler, special electronic equipment heater, flood lights, UHF heaters, console lighting, instrument lighting, pitot heat, IFF and UHF. The C-phase provides power for taxi and landing lights, and flight recorder pitot heat.

b. The outputs of the two T-R units are connected in parallel to the DC essential bus and the DC monitored bus. Each T-R is rated at 200 amperes and one of them is capable of providing the entire DC load for an indefinite period. Emergency DC power is provided by two silver-zinc batteries, each of which has a rated capacity of 25 ampere-hours. In the event both T-R units fail, the batteries supply power to the DC essential bus only. The DC monitored bus is connected upstream of the essential bus relay. The monitored bus is therefore not energized when the essential bus is energized by the battery. All DC power to the aircraft is supplied by the essential bus except the Q-bay and INS equipment which is powered by the monitored bus.

c. The regulated AC power source is provided by three solid-state, 600 VA inverters. Each inverter furnishes power to individual loads. A fourth identical inverter is used as an emergency source of power. It can be switched to any of the three individual loads by / manual means.

**OXBART SECRET**

**OX CART SECRET**

2. Investigation and Analysis.

a. The LH generator (S/N 136) was recovered still attached to the gear box. The two hydraulic pumps that are driven by the same gear box were also attached. The generator was removed from the gear box in the normal manner. The rotor turned freely but the shaft was slightly bent as a result of lateral movement of the generator induced by impact. Disassembly showed scrolling of the armature and output field assemblies indicating rotation at the time of impact. The RH generator (S/N 138) was still attached to a portion of the associated gear box. When separated from the latter, it was found that the quill shaft was broken at the shear section by lateral bending while rotating. When the armature was removed, severe scrolling was found on the rotating field poles and the fixed field poles. Scrolling of the armature and output field assemblies was also in evidence. The windings of both generators were checked with a PSM-6 volt-ohmmeter. The output fields were uniform, phase to phase, all showing a resistance of near zero with the meter in the X1 scale. The exciter and generator fixed field windings all showed a resistance of approximately 0.5 ohm with the meter in the X1 scale. The bearings of both generators were considered serviceable before the accident and were well lubricated.

b. The generator contactors and the bus-tie contactor all showed evidence of severe impact damage and ground fire. Disassembly showed normal appearing contacts and no signs of malfunction prior to impact. A considerable number of fixed contacts were pulled away by tension imposed by the heavy leads connected to them. All of these were seen and there was no unusual evidence.

c. Both generator control units contained evidence of severe impact and/or ground fire damage. There was no evidence of overheat or mechanical malfunction prior to impact.

d. Both T-R units retained their identity but sustained considerable impact damage. There was no evidence to indicate failure before impact.

e. The LH battery (S/N 48) was recovered in an unusually good condition. The case was bent and dented but retained its original shape. The RH battery (S/N 16) or recognizable parts thereof had not been located.

f. All four inverters were recovered. These inverters being a solid-state design and having no rotating parts, could show no evidence of scrolling that is indicative of rotary inverters. There was no evidence of overheat before impact and the testimony of the pilot did not include any mention of an inverter malfunction which would call for a manual selection of the spare inverter after the display of an inverter failure warning light.

g. Parts of four fuel booster pumps were noted to contain evidence of scrolling that was deep enough and/or unsymmetrical to conclude that they were rotating at the time of impact. This supports evidence that AC power was available from at least one AC generator since these pumps are driven by 3-phase variable frequency power.

**OX CART SECRET**

~~TOP SECRET~~

h. The trim switch, a part of the control stick grip was recovered unattached. This switch controls pitch trim and yaw trim. Half of the cylindrical case was broken away and the "C" and "P" fixed contacts were missing as a result of tension of wires connected to them. All contacts present were free of evidence of pitting or arcing. The typical discoloration borne by the contacts indicate that the switch armature, a cubically shaped block of metal, had been contacting the fixed contacts at the upper edge only. This was true of all four contacts as evidenced by the discoloration on the switch armature. Preferably, the flat surfaces of the armature should meet the flat surfaces of the fixed contacts in a parallel manner when the switch is actuated to full travel in any of the four directions. A number of switches, picked at random, could be X-rayed while held in each of the four positions to show whether the flat surfaces of the armature are contacting the flat surfaces of each fixed contact squarely. This discrepancy did not contribute to the cause of the accident. It involves quality control to insure longer life and minimum contact resistance.

i. An inspection of aircraft wiring showed no evidence of arcing, burning or overheat prior to impact.

## B. ELECTRONIC SYSTEM

### 1. System Description.

a. The electronic system, per se, involves numerous sub-systems linked with other aircraft systems, particularly those associated with the flight control system. Since electronic sub-systems are discussed in other applicable Group Reports, the sub-systems mentioned herein are those associated with the communication, navigation and other sub-systems on which work was done.

b. The communication system includes:

(1) AIC-10 interphone system for communication with ground crew.

(2) ARC-50 UHF communication.

(3) 618-T single side band HF communication.

c. The identification equipment includes the APX-46 IFF set.

d. The navigation system includes:

(1) ARA-50, used in conjunction with the ARC-50 to provide UHF/DF.

(2) DF-203 for LF/MF ADF capability.

~~TOP SECRET~~

~~SECRET~~ SECRET

(3) ARC-15F VHF navigation, 108 mc. to 126.9 mc. This sub-system includes a glide slope receiver.

(4) DME capability is provided by a tie-in with the ARC-50 UHF set.

(5) 109-C/A Lockheed Flight Recorder. This is a modified version of the model used by civil air carriers. Modifications include higher speed and altitude capability in consonance with the A-12 flight performance. The aluminum alloy tape was replaced by inconel tape to withstand greater impact and fire damage. The flight recorder is installed in the RH chine. It records airspeed, altitude, heading and vertical acceleration against a base which is a function of tape speed. The flight recorder requires regulated AC power (Nr. 3 inverter).

(6) A dictaphone recorder, trade name: "Dictet Recorder" is carried in the cockpit during all test flights. It is connected to the interphone system and records all communication associated with the pilot's microphone. It does not record any outputs from radio receiver sub-systems. In addition to normal communication, pilots use the voice recorder as a means of recording events in lieu of logging them in writing. The voice recorder has self-contained batteries and utilizes the same type of mylar type that is used in home recorders.

## 2. Investigation and Analysis.

a. Not all of the components of the systems described above were found in a recognizable state. Those that were provided no useful information. Damage was generally severe as a result of impact and/or ground fire.

b. The history of flight, air-to-air and air-ground communication and the voice recorder tape transcript indicated that there were no difficulties experienced with these systems (see Operations and Witness Group Report).

c. The tape cassette of the flight recorder was recovered in a badly damaged condition. It appeared that the critical portion of the tape which recorded the parameters during the latter part of the flight was missing. The tape cassette, together with the tape in evidence, was forwarded to Lockheed Aircraft Service (LAS), Ontario, for data reduction. In addition, fifteen people searched the likely areas for any missing tape. No part of the tape was recovered.

d. The tape recovered from the voice recorder contained the usual type of conversation and events. The last recording was: "When I trim, just the right rudder trims, as ..... the indicator.....". The tape ripped at this point.

~~SECRET~~ SECRET

~~SECRET~~ SECRET

e. It was evident that the LAS flight recorder did not withstand impact damage to the desired degree. The two halves of the sphere and the tape cassette were recovered at different locations at the impact scene. It is also evident that more parameters are necessary in order to derive needed flight data for the type of aircraft involved. It is considered necessary to provide a means of ejecting the tape cassette portion of a flight recorder in order to derive the maximum probability that the tape will be recovered in an undamaged state. In this particular case, fire damage was not a factor. Past studies in regard to crash-resistant flight recorders dictate the necessity to install them in the empennage in order to derive maximum tape protection in the event of an accident, particularly those types that are not ejectable.

f. The Stability Augmentation System (SAS Autopilot) A/P Function Select Panel was examined (see AFCS and ADS Report). The purpose was to determine if any of the channel disengage warning lamps were illuminated at the time of impact. The Pitch-A and Pitch-B warning lamps were missing. The lamps for the following bore evidence of no illumination at the time of impact: Pitch-M, Yaw-B, Yaw-M and Roll Monitor. The Yaw-A lamp had evidence of illumination at the time of impact since the helical filament was stretched apart in addition to being broke.

g. An inspection of the Air Data Computer for mechanical evidence of airspeed, Mach number and altitude outputs indicated no useful information.

## C. INSTRUMENTS

### 1. System Description.

a. The majority of the instruments installed are conventional types. Those associated with radio navigation are the same as those used in other aircraft. Some engine instruments are peculiar to this type of aircraft. The RPM indicators are read as engine rpm instead of percentage rpm. The engine air inlet system is peculiar to this airplane. In this airplane there is a system called the Onion Slicer (one per engine nacelle). It is presently an experimental system and is, in effect an additional air by-pass door. In this airplane the system was manually controlled. The two instruments that indicate the position of these doors are identified as Onion Slicer Position indicators (OSP). Many of the transmitters and transducers are linear types and are unusual in that they operate under extremely high temperature environments. Most of these instruments have been modified by the airframe manufacturer by the addition of a jacket through which aircraft fuel flows for cooling.

### 2. Investigation and Analysis:

a. The cockpit instruments that were recovered included:

SECRET



## SECRET

(1) Flight Instruments - Attitude indicator (MM-3), Turn & Slip Ind., Airspeed Ind., Airspeed Display Ind., Altimeter, Radio Magnetic Ind. (RMI), Vertical Speed Ind., and Course Ind. (VOR/ILS), and Hack Watch.

(2) Engine Instruments - Two EGT Ind., two RPM Ind., two Exhaust Nozzle Position Ind., two Fuel Flow Ind., one Oil Temp. Ind., one Compressor Temp. (CIT) Ind. (one per acft, two pointers), and ENP Transducer.

(3) System Instruments - A and B Hydraulic Pressure Ind., L and R Hydraulic Pressure Ind., Liquid Nitrogen Quantity Ind. (2), Fuel Quantity Ind. OS Ind. (2), LOX Quantity Ind. and Roll Trim Ind.

b. Except as noted in the following, very little information could be derived from the instruments as a result of impact and fire damage. The only instruments from which valid information could be obtained were the EGT indicators, Liquid Nitrogen indicators and the LOX Quantity indicator. These readings were:

(1) LH EGT Ind.: 705 deg. C. RH EGT Ind.: 668 deg. C.

(2) Liquid Nitrogen Quantity Ind's. One read 12 liters, the other 58 liters.

(3) LOX Quantity Ind.: 4.75 liters.

c. An exhaust nozzle position transducer was analyzed. It was not known on which engine this transducer was installed. The slug which is connected to the ENP to the linkage was captured by impact. By means of a voltage ratio test, the slug position corresponded to a nozzle position of approximately 20% OPEN. A serviceable transducer showed that the slug could be moved easily by gravity when manipulating the assembly by hand. This ENP position is therefore not considered absolutely valid.

d. There was no evidence to indicate that the instrument system contributed to the cause of the accident.

### D. FINDINGS

1. Variable frequency AC power, DC power and regulated AC power were available during the entire flight.

2. There was no evidence to indicate that the electrical, electronic or instrument systems contributed to the cause of the accident.

3. The flight recorder does not have a sufficient number of parameters to provide a meaningful and complete flight data history.

## OX CART SECRET

**OX CART SECRET**

4. The tape cassette of the flight recorder is highly susceptible to impact and fire damage.

5. The trim switch evidence showed the need for better quality control to insure minimum contact resistance.

E. RECOMMENDATIONS

1. Consider the installation of a more modern crash-resistant flight recorder with the tape cassette installed in the canopy.

2. The airframe manufacturer request better quality control of trim switches on the part of the vendor.

25X1A



Electronics Engineer (Gen)  
D/TIG, USAF  
Group Leader

25X1A



Senior Service Engineer  
Lockheed Aircraft Corp.  
Member

**OX CART SECRET**

LIFE

SCIENCES

GROUP

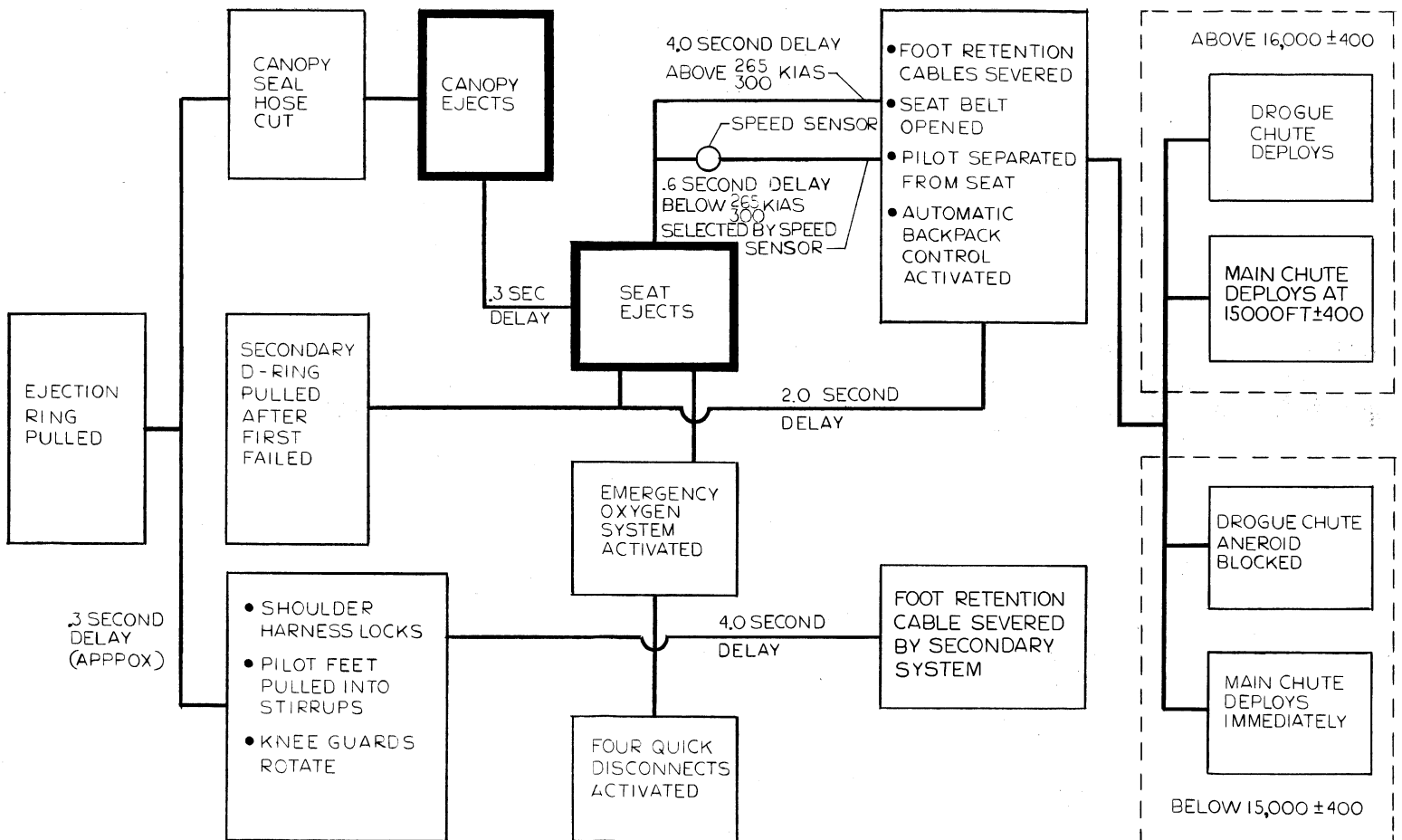

~~SECRET~~  
LIFE SCIENCES GROUP

Investigation of major accident involving A-12 aircraft S/N 133 which occurred at Det 1, 1129th USAF SAS, Las Vegas, Nevada on 9 July 1964.

A. ESCAPE SYSTEM

1. Full Pressure Suit Assembly.

a. Description: A full pressure suit is provided which is capable of furnishing the pilot with a safe environment exclusive of pressure conditions in the cockpit.

(1) The suit consists of four (4) layers:

(a) Ventilation garment: The ventilation garment layer allows vent air to circulate between the pilot's underwear and the bladder layer.

(b) Bladder layer: The bladder provides an air tight seal to hold pressurized air in the suit.

(c) Link net: The link net layer is a woven mesh which holds the suit in conformance with the pilots body.

(d) Heat reflective garment: The outer garment is a heat reflective aluminized fabric which provides protection from a hot environment.

(2) Air pressure in the suit is regulated by a suit controller valve that is located on the side of the suit just above the waist on the right side. Vent air is drawn into the suit from an aircraft installed system; it has a flow control located on the suit attachment on the front of the suit just above the waist on the left side. Breathing oxygen is provided through the suit's oxygen inlet. It is routed inside the suit to the helmet regulator and through the helmet plumbing to the pilot.

(3) This particular suit is a prototype rear entry suit (with back entry zipper).

b. Investigation: Inspection of the suit and components shows slight scratches on the right rear of the helmet and the right side of the glare shield. There were no tears or scratches on the suit itself or on the gloves. The boots had some scuffing from ground impact. The spurs were intact and had caused some gouging of the shoe heels from ejection and impact. The right spur cable was still attached to the boot after the suit was doffed. The whole suit assembly was very dusty and had dirt particles in and around all projections and openings. The suit had a black residue approximately 3 inches in diameter on the left center chest area. This is attributed to powder burns from seat belt firing. The helmet hold down assembly had a wear or abrasion area and a black residue similar to that on the suit. At post flight inspection all components functioned properly with the exception of a high suit leak rate when pressurized. The high leak rates were attributed to dust and

~~SECRET~~

**SECRET**

dirt which entered the neck ring during landing. After normal maintenance and cleaning of the neck ring, the leak rates were in the prescribed tolerances. Investigation shows that the pilot was able to remove the suit with a minimum of help immediately after the incident, because of ease of doffing the rear entry configuration.

## 2. Ejection Seat.

a. Description: The ejection seat system consists of a modified C-2 Rocket-Catapult Upward Ejection Seat, an adjustable seat guide rail assembly, a jettisonable canopy, and necessary controls and ballistics for seat operation and ejection. The metal bucket-type seat is mounted on the guide rails so that during ejection it will be catapulted up the rails clear of the aircraft. The seat incorporates the following design features:

- (1) Contoured headrest for positioning and support of the pilot's head during ejection.
- (2) Centrally located primary D- Ring which initiates the entire ejection sequence and precludes arm flailing after ejection.
- (3) A secondary back-up D-Ring which fires the catapult directly by means of a pin-pulled initiator. It is required that the canopy be jettisoned manually before using the second system.
- (4) Shoulder harness and inertia reel lock assembly which locks the shoulder harness automatically during ejection or anytime forward acceleration exceeds 2 to 3 gs.
- (5) Leg guards which automatically rotate forward to protect the pilot's legs during ejection.
- (6) Positive automatic foot retraction, retention, and separation system.
- (7) MA-5 Automatic-opening seat belt.
- (8) Speed sensor which automatically selects one of two seat separation delays depending on airspeed at ejection.
- (9) Positive, automatic pilot-seat separation device.
- (10) Auxillary, manually controlled foot-retention separation system.
- (11) Automatic disconnect of all seat-to-aircraft and pilot-to-seat connections.
- (12) A control lever located on the left side of the seat bucket is used to manually lock or unlock the shoulder harness.
- (13) The primary and secondary D-Ring are safetied in position by a single safety pin inserted through the D-Ring housing. This secures

**SECRET**

**OX CART SECRET**

the D-Ring in its stowed position and prevents accidental actuation of the ejection system on the ground.

(14) The dual - oxygen system disconnect is attached to the forward edge of the seat bucket, accessible and within sight of pilot. A bayonet fitting is safety-wired into the disconnect casting and when in position secures the disconnect fitting. A lanyard secures the bayonet fitting to the cockpit floor so that when the seat moves up the rails, the bayonet is pulled, freeing the lines on both sides of the disconnect.

(15) Pilot-seat separation system consists of a ballistic rotary actuator mounted behind the headrest, and a Y-shaped harness assembly which is attached to the rotary actuator reel that lays over the front face of the seat and attaches at two points on the front lip of the seat bucket. Upon ejection, gas pressure from the seat belt and separation initiator fires the cartridge in the rotary actuator. The gas pressure forces the actuator to rotate and wind up the strap which reels in the webbing. This pulls the webbing taut between the actuator and the front of the seat bucket, forcefully separating the pilot from the seat.

(16) The emergency oxygen actuating lanyard and automatic disconnect consists of two lanyards; one connected to the oxygen actuator in the back pack and one connected to the aircraft. The two cables are secured together by a ball-lock disconnect fitting which separate on seat ejection actuating the emergency oxygen.

b. Investigation: See photos #4635, 4634, 4527, and 4531. Seat ejection and pilot recovery were satisfactory and Mr. Park made no criticism of the seat or parachute recovery system.

(1) Inspection of the seat and ballistic components indicated that the seat performed properly throughout the ejection sequence.

(a) The initiators were removed from the seat and it was determined that they fired in the proper sequence. The foot-retention cable cutters fired twice on schedule, initially at .6 seconds and then again at 4.0 seconds. The cutters are pre-scheduled to fire at four seconds at all times and the speed sensor cuts in the .6 second cable cutter when the speed falls below 265 knots. The foot retention cables show a clean cut.

(b) The internal canopy jettison initiator was fired after impact. This was determined by the internal position of the jettison valve.

(c) The backup D-Ring initiator was fired on seat impact. The oxygen disconnect indicated normal expected separation, and likewise the vent air disconnect separated properly.

(d) The speed sensor was in the below 265 KIAS position which permitted the .6 second seat separation.

**OX CART SECRET**

**EXHIBIT SECRET**

(e) The leg thrusters were erected and the seat separator fired. The lap belt fired leaving powder deposits; and the parachute arming cable remained attached to the seat belt in the proper manner.

(2) One cable end with the ball remained in the pilot's shoe, and the other landed 24 yards down stream from pilot. The parachute quarter bag landed 54 yards upstream from the pilot and the seat landed 34 yards down stream from the pilot. The close proximity of these objects indicate the very small amount of time from ejection to ground impact by the pilot.

(3) The pilot landed 71 yards from the estimated path of the airplane. In a sled ejection at Edwards AFB at 233 KIAS an altitude of 150 feet was achieved. About 71 yards (213 feet) from the estimated path of flight was the point of pilot's impact, the angle of ejection appears to have been a small amount above horizontal. In the same Edwards sled ejection at 233 kts the sled from ejection to ground impact of the dummy and parachute was approximately 1.5 seconds. And the distance from ejection to ground impact was 90 feet.

(4) The cushion used on the pilot's seat kit was a newly developed type which provides greater comfort. This cushion provides more support area and is deeper than the original cushion. During development of this greater depth cushion, consideration was given to objections to use of a soft cushion on ejectable seats. It is suspected that back injuries may occur when a soft cushion bottoms out. However, this new cushion has limited vertical travel to full compressibility under vertical accelerations. [REDACTED] ejected with his head down and forward without the supporting benefit of a headrest. He reported only minimal soreness of back muscles. The Flight Surgeon's examination revealed no injury except minimal muscle strain from forces of ejection, opening shock and parachute landing. It is therefore considered that the new cushion proved satisfactory in actual test under high seat accelerations.

25X1A

### 3. Parachute System.

a. Description: This is a two-stage back type parachute. The system is fully automatic following the arming which occurs at time of man/seat separation. A manual over ride is provided for deploying the main recovery 'chute only. The system consists of:

(1) Drogue Parachute - This is a 78 inch diameter hemisflow canopy of ribbon construction. The drogue is deployed automatically at any altitude over 17,000 feet and provides a stable descent.

(2) Drogue Jettison Devices - The drogue risers are attached to the parachute harness by two specialized fittings that permit jettisoning of the drogue when actuated at 15,800 feet  $\pm$  400 feet.

(3) Main recovery parachute - This is a 35 foot diameter flat circular canopy with a 10% extended skirt stowed in a deployment bag.

**EXHIBIT SECRET**



## SECRET

The canopy is deployed automatically at 15,000 feet  $\pm$  400 feet following the jettisoning of the drogue. In case of ejection below 15,000 feet  $\pm$  400 feet the canopy deploys immediately following man/seat separation.

(4) Harness - The harness is not separable from the container. Suspension from the main canopy is conventional but a more aft suspension is supplied for the drogue. Quick adjustment features allow ease of fitting for most sizes of men in the pilot category.

(5) Container - The fabric container encases the two parachutes as well as a metal container, contoured to the back. The automatic parachute actuators and the emergency oxygen system are secured in the metal container.

(6) Automatic Parachute Actuators - There are three of these, one each to deploy the drogue at any altitude above 16,000  $\pm$  400 feet, jettison the drogue at 15,800  $\pm$  400 feet and deploy the main canopy at any altitude below 15,000  $\pm$  400 feet. These are each controlled by aneroids which trigger power packs consisting of Belleville washers. Power is supplied for a 2 inch stroke with 200 pounds at start and 50 pounds at  $1\frac{1}{2}$  inches of travel. The power stroke starts immediately following triggering by the aneroid.

(7) Emergency Oxygen System - The emergency oxygen consists of two separate but identical systems that are actuated automatically at time of ejection or may be actuated manually at any time. Total Volume of stored oxygen is 120 cubic inch at 2100 PSI.

(8) Rocket Jet Releases - Each of the two main parachute risers is attached to the harness by a rocket jet release. The original equipment consisted of Capewell releases, which are in common use in the Air Force. However, because of the bulk required in the shoulder area for this two stage (drogue and main) system, the Capewell release proved too large and heavy. Pilot dissatisfaction resulted in a change to a rocket jet release. This release, as extensively used by the Navy, was modified to add a roll bar safety lock to guard against inadvertent release.

b. Investigation: See photo #4528. The parachute system received its periodic inspection on 16 June 1964. It was preflighted on 9 July 1964. The complete system was recovered undamaged. The parachute performed as scheduled, and obviously opened in record time. The drogue chute was not deployed, and the drogue risers were jettisoned as scheduled in the sequencing mode. The rocket jet releases had not been used. Although [REDACTED] was being dragged by the parachute, he states he pulled on the risers in preference to attempting use of the quick releases.

25X1A

#### 4. Emergency Oxygen System:

a. Description: Two independent emergency oxygen systems are installed in the pilot's parachute pack. Each system consists of three 20 cubic inch, 2100 PSI cylinders attached to a common manifold. These

## SECRET

SECRET

systems will supply oxygen automatically during bail out or if the aircraft oxygen system fails and is depleted. An oxygen line from each system is routed both above and below the pilot's waist to the suit controller. Check valves prevent oxygen flow when the aircraft systems are supplying oxygen. When the emergency system is activated, check valves prevent oxygen flow into the aircraft oxygen system. Oxygen duration of each emergency system is approximately fifteen minutes. The emergency oxygen system may be activated either manually, by pulling the conventional green apple, or automatically, by the upward motion of the seat during ejection.

b. Investigation: Periodic inspection of the emergency oxygen system was conducted on 16 June 64 with no discrepancies. Preflight inspection on 9 July 64 indicated a full (2100 PSI) system. All components were recovered intact and undamaged. Inspection shows that the system was automatically activated as scheduled during ejection. According to the pilot's statement, oxygen was flowing when he disconnected the emergency hoses in removal of his parachute harness. The system was depleted, as expected, on activation. It should be noted that, since the face visor was open, there was a rapid flow of oxygen about the pilot's face throughout the ejection sequence.

#### 5. Survival Kit.

a. Description: The reinforced fiberglass survival kit container fits into the seat bucket and is attached to the parachute by snap attachments on each side. A release handle is provided to separate the kit from the pilot before parachute landing.

b. Investigation: The kit was recovered intact and undamaged. Inspection showed the contents (survival gear) present and undamaged. The release handle had not been pulled, thus the kit was still attached directly to the parachute harness. Physical examination of the pilot showed no bruising or other damage to him from failure to release the kit prior to impact.

#### B. FLIGHT SURGEON'S NARRATIVE

STATOTHR

SECRET

SECRET

3. There is no indication of any physical or physiological problems being experienced by the pilot during the flight. At the time of the ejection he was wearing a specially configured pressure suit, helmet, gloves and boots. Fuller description of these items is contained elsewhere in the report. The helmet visor had been opened at 15,000 feet, as apparently is the pilot's habit. However, rate of descent was rapid so that only about one minute elapsed breathing cabin air before 10,000 feet was reached. Many pilots land with the visor up because of reflection problems. Ejection altitude is estimated at 200 feet, airspeed estimated at 200 knots. The aircraft attitude was a left bank greater than 45° and less than 90° with the nose near level.

4. The pilot's narrative of the ejection sequence, as paraphrased by the examining flight surgeon is as follows: "I realized I had no control over the aircraft and I reached down and pulled the D-Ring. For a brief instant I felt that nothing happened. I thought 'it's not going to work'. Then I got the kick in my pants. I don't remember separating from the seat. I was almost instantly aware of the chute opening above me. Just as I thought I had better get my feet together before I hit, I contacted the ground. I was going backwards with my back toward the ground. I took a backward tumble. I was aware of my open face plate dragging through the dust and saw the flames awfully close. I felt the heat of the fire on my face. My arms were slightly tangled in the risers and I reached up and pulled very hard on two of them to collapse the chute. I guess that I just stood up then looking at the fire and thinking of how close that one was. Then [redacted] came by in the mobile vehicle. He helped me out of the suit and into the car." Additional discussion with the pilot indicates at time of pulling the D-Ring, he had his head down and his eyes shut. He does recall a sensation of tumbling (eyes still closed) and "straps flailing around." He did not release the seat kit (and probably did not have time to do this).

25X1A

5. Examination of recovered equipment, as noted in the report, reveals that all systems functioned normally. Canopy firing, foot retraction, extension of knee restraints, seat firing, activation of emergency oxygen, disconnection of all leads (oxygen, communication, suit vent), foot cable cutting, lap belt firing, positive seat separation, and parachute opening all occurred sequentially and cleanly.

6. Reported surface wind was 210° at 10 knots, gusting to 13 knots. Correlation of pilot's statements and ground marking indicates he landed on his feet while drifting backward. He sat or fell backward onto his seat kit and then turned (or somersaulted) onto his face. He was dragged less than 10 feet. He states he pulled on the shroud lines because he was in "too much of a hurry to use the riser quick releases."

7. The pilot, unassisted, disentangled his arms from the shroud lines, and unbuckled his parachute harness. In disconnecting his emergency oxygen hoses from his suit, he noted the hiss of escaping gas. At this point it should be mentioned that there is no on-off valve incorporated into the helmet visor. Therefore, there was a considerable flow of oxygen about the face once the emergency supply was automatically activated, since the visor was open. See suit report.

OXGART SECRET

~~SECRET~~ SECRET

25X1A

8. The pilot was recovered by the mobile control officer who assisted him from his suit. This suit of [REDACTED] is unique in that it has a back opening zipper. Doffing was simple and rapid, in contrast to the standard around-the-torso zipper configuration.

9. Physical examination of the pilot is reported as follows:

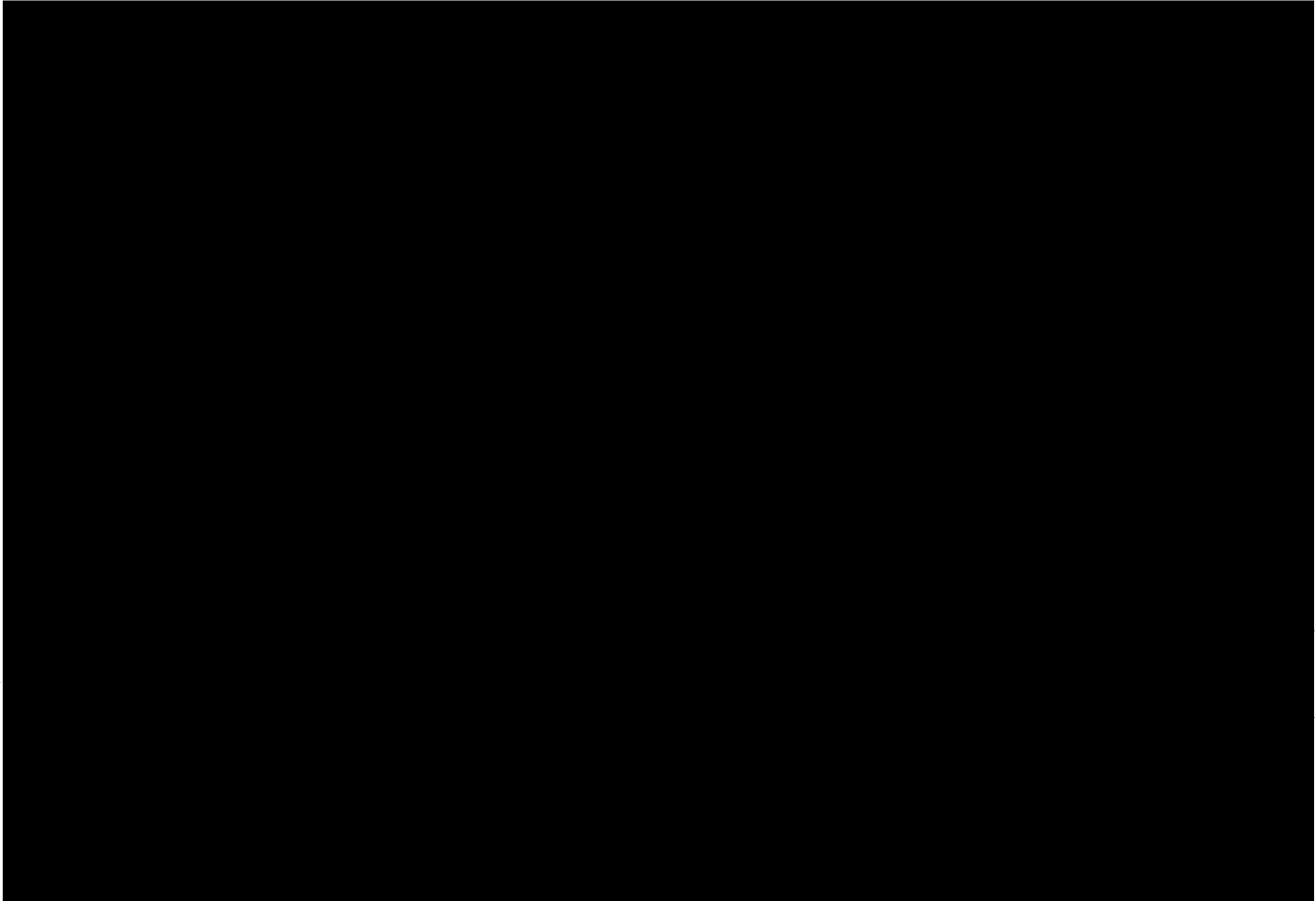

C. FINDINGS

1. The pilot was physically qualified for full flying duty.
2. The escape system functioned in a superior manner, under extremely critical conditions of altitude and attitude.
3. Any delay in initiating the ejection sequence would probably have been fatal. A one-step procedure saved this pilot's life.
4. A definite hazard existed with a high flow of oxygen about the pilot's face from the emergency system. Ignition by the seat rocket or by the ground fire could have given him serious burns.

~~SECRET~~ SECRET

STATOTHR

**SECRET**

5. The riser quick releases were not used.

6. The pilot was rapidly removed from his pressure suit in the field.

D. RECOMMENDATIONS

1. This specially designed escape system should be carefully evaluated to utilize its advantages in design or modification of other aircraft.

2. An on-off valve should be incorporated into the helmet visor control, to insure no flow when the visor is in the up position.

3. Pilots using this parachute should be trained in use of the riser quick releases. If difficulty is encountered in their use after practice, redesign should be accomplished.

4. Modification of the pressure suit to the back zipper configuration should be considered.

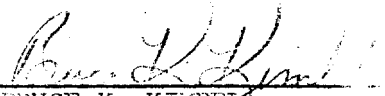
  
BRUCE K. KIMBEL  
Major, USAF, MC FS

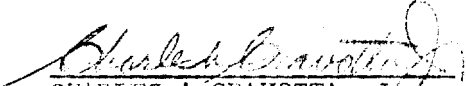
  
CHARLES A. CRAVOTTA, Jr.  
Captain, USAF  
Physiological Training Officer

25X1A



Design Specialist  
Lockheed Aircraft

25X1A

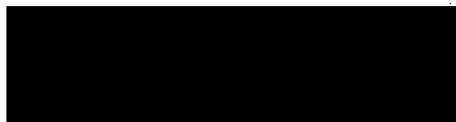

Technical Representative  
Firewel Company

25X1A



WALTER S. HANB  
Technical Representative  
David Clark Company

**SECRET**

**OX CART** **SECRET**

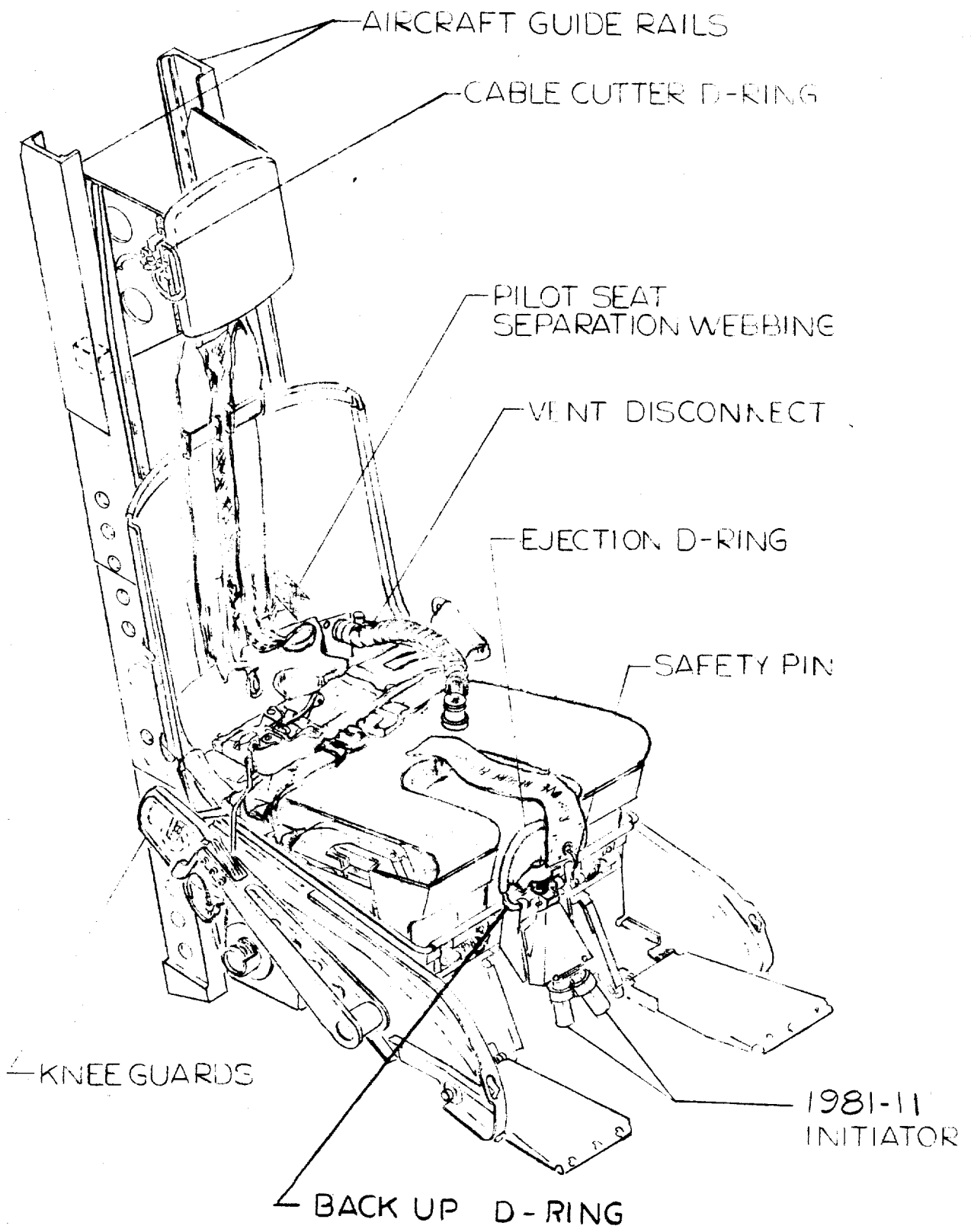

**OX CART** **SECRET**

AIR CONDITIONING

AND

PRESSURIZATION

GROUP

AIR CONDITIONING

SYSTEMS GROUP

Investigation of major accident involving F-12 Aircraft S/N 133 which occurred at Detachment 1, 17th Street, P. O. Box 882, Las Vegas, Nevada, on 7 July 1964.

A. SYSTEM OPERATION:

1. Dual air conditioning systems, completely parallel, bleed off air from the compressor section of the engine and introduce it at pilot-selected temperatures into the cockpit and nose (L.H. system air) and the equipment bay (R.H. system air). All of the ventilated compartments aft of the cockpit are then cooled by the combined airflow of both systems.

2. Single system emergency operation is possible; however, all compartment temperatures will be appreciably higher except for the cockpit, which is always furnished with the output of the operating system. (In case of engine failure or air conditioning system failure, a cross over valve transfers the R.H. system from the equipment bay to the cockpit).

3. In each system the cooling of the engine bleed air is accomplished in three steps, utilizing ram air cooling in the primary stages, followed by a "bootstrap" air-cooled turbofan with fuel inter-cooling. Compartment inlet temperature is controlled in either AUTO or MANUAL mode by mixing hot bypass air with the turbofan refrigerant discharge.

4. Pressurization of the cockpit is accomplished by control of its cooling air outflow, utilizing separate pressure regulation and safety valves. The control schedule established by the pressure regulator allows an unpressurized climb or descent when the cockpit altitude is below 26,000 feet; at all higher aircraft altitudes the compartment remains isobaric at the 26,000 feet pressure level. The resultant pressure differential reaches a maximum of 5.00 psig at highest cruise altitude. The cockpit safety valve setting is 5.00 psig, irrespective of aircraft altitude.

5. The series airflow path through the compartments aft of the cockpit serves inherently to provide dual cockpit pressure reliability, in that the similar pressure control valves of the equipment bay serve as a backup system for the cockpit at only slightly higher compartment altitude (27,700 feet isobaric).

6. The pilot can energize both safety valves to full open position by selecting the PRESSURE DUMP position of a guarded dump switch; this action depressurizes all compartments. Both of the safety valves also feature automatic opening for vacuum relief operation (inflow of air during high speed dives).

B. INVESTIGATION AND ANALYSIS: The components of this system were too badly damaged to warrant judgment as to their functional status prior to

OXFORD SECRET



**SECRET**

impact; however, the pilot's actions indicate that the air conditioning had performed satisfactorily during the flight. It is considered that the cooling and pressurization system did not contribute to this accident.

C. FINDINGS

Subject system operation had no bearing on this accident.

D. RECOMMENDATIONS: None.

25X1A

[REDACTED]

25X1A

Technical Consultant  
Directorate Aerospace Safety

[REDACTED]

Air Conditioning and Pressurization  
Engineer  
Lockheed A/C Corp

[REDACTED]

25X1A

Division Engineer  
Lockheed A/C Corp

**SECRET**

**SECRET**

MAINTENANCE

AND

RECORDS

GROUP

~~SECRET~~

MAINTENANCE, INSPECTION AND RECORDS GROUP

Investigation of major accident involving A-12 aircraft s/n 133 which occurred at Det 1, 1129th SAS, Las Vegas, Nevada, on 9 July 1964.

A. Investigation and Analysis

1. DD 829 - Historical Records of Aeronautical Equipment, Aircraft Engines and Afterburner.
2. DD 829-1 - Historical Records, Technical Instructions Compliance.
3. AFTO 781 Series.
4. AFTO 44 - Turbine Wheel Historical Records.
5. AFTO 98 - Engine and Afterburner Replacement Records.
6. AFTO 100A.
7. Pertinent contractor inspection records for all systems, Inertial Navigation and Stability Augmentation System.

B. Historical Data

1. The first flight was flown on 27 May 1964 for a duration of 00:49. Total flight time prior to take-off on the tenth flight was 07:09. Reported duration of the tenth flight was 01:11.
2. Review of maintenance records.
  - a. Post flight inspection following the ninth flight was completed on 7 July 1964.
  - b. Pre-flight inspection for the tenth flight was completed on 9 July 1964.

C. Summary of Outstanding Discrepancies from AFTO 781B, Part E

1. Compass swing not complied with.

D. In-Flight Discrepancies and Corrective Measures. Recorded for all flights.

1. Flight #1, 27 May 1964, flight time 00:49
  - a. Discrepancy: F.C.F. required for aircraft and engines I/A/W T.O. 1-1-300 to complete inspection.
  - b. Corrective Action: Aircraft test flight completed and accepted, aircraft hereby released for flight. Pilot: [REDACTED]

25X1A

~~SECRET~~

~~SECRET~~

- c. Discrepancy: Artificial horizon inoperative.
  - d. Corrective Action: Replaced broken wire lugs on C10 terminal number 12.
  - e. Discrepancy: Rt hand bypass door not open lite illuminated after T.O.
  - f. Corrective Action: Readjusted bumper switch R/H wheel well. Recheck on next flight.
  - g. Discrepancy: R/H engine - surge at mil to 7100 back down to 6750 R.P.M.
  - h. Corrective Action: Removed P648232 engine and replaced with P648234 engine.
  - i. Discrepancy: Gear lite - illuminates red upon minor throttle reaction above 10M'.
  - j. Corrective Action: Reset switches per eng. W.O. 3/8 to 1/2 inches above idle position.
  - k. Discrepancy: Air conditioning surges in auto.
  - l. Corrective Action: Replaced temp control box. Check on eng run appears OK on grd. eng. run. Recheck in flight.
  - m. Discrepancy: U.H.F. receiver marginal.
  - n. Corrective Action: Found loose modum module. Tighten module also readjusted squelch. Checks good now.
2. Flight #2, 2 June 1964, flight time 01:07.
- a. Discrepancy: F.C.F. required on R/H engine I/A/W T.O. 1-1-300 to complete inspection.
  - b. Corrective Action: Aircraft test flight completed and accepted, aircraft hereby released for flight. Pilot: [REDACTED] 25X1A
  - c. Discrepancy: Cockpit pressurization pulsates in auto.
  - d. Corrective Action: Replaced L/H sensor and L/H hi limit switch.
  - e. Discrepancy: Right engine stalled at 2.62 M @ 69 K.
  - f. Corrective Action: Adjustment of bypass panels should correct this condition. [REDACTED] checked.

~~SECRET~~

~~SECRET~~

g. Discrepancy: Right and left bypass door not open lights came on with bypass switches in auto.

h. Corrective Action: Reamed bypass screen panels to allow clearance for full opening of panels.

i. Discrepancy: Nitrogen system bled down to approx 25 liters.

j. Corrective Action: Circuit breaker was accidentally turned off when protective cover was put on causing loss of control to circuit.

k. Discrepancy: The H.F. receiver appears to be inoperative.

l. Corrective Action: Ground station was off the air.

3. Flight #3, 3 June 1964, flight time - aborted.

a. Discrepancy: L.H. engine pressure dropped to 2600 PSI.

b. Corrective Action: Replaced L.H. system hydro pump.

4. Flight #3, 5 June 1964, flight time 00:51.

a. Discrepancy: O<sub>2</sub> and N<sub>2</sub> both depleted to zero.

b. Corrective Action: Replaced vent relief valve also #2 system regulator.

c. Discrepancy: Engine (IH) stalled at 2.61 Mach.

d. Corrective Action: Replaced bypass door actuator feed back arm.

e. Discrepancy: Air conditioning - surges on L.H. engine manually, auto. OK on crossover.

f. Corrective Action: Replaced cockpit rheostat control. Run made and checked out OK.

g. Discrepancy: R/H bypass doors lite not closed came on in auto.

h. Corrective Action: Readjusted bumper switch spring assy. to 45 oz  $\pm$  8 oz. Grd. check OK.

i. Discrepancy: U.H.F. transmitter weak and semi-operative.

j. Corrective Action: Unit was lab checked for over 2 hrs and checked good.

k. Discrepancy: L.H. bypass door not open lite did not illuminate when manually open selected.

l. Corrective Action: Replaced bypass door actuator feed back arm.

m. Discrepancy: L.H. bypass door not open lite in pattern, in auto with gear down - R/H was not illuminated.

n. Corrective Action: Replaced bypass door actuator feed back arm.

5. Flight #4, 19 June 1964, Flight time 00:59.

a. Discrepancy: P.C.F. required for engines I/A/W T.O. 1-1-300 to complete inspection.

b. Corrective Action: Aircraft test flight completed and accepted, aircraft hereby released for flight 19-06-64 1730. Pilot: ████████ 25X1A

c. Discrepancy: A yaw lite and B yaw lite came on during flight.

d. Corrective Action: B yaw caused by intermitten open B.R. L.V.D.T. connector repaired. Yaw H cause not found. Preflight completed.

e. Discrepancy: ADF point 150° out.

f. Corrective Action: Wired improperly and terminal E1, 23 & 24 were transposed. Rewire per B/P 918.

g. Discrepancy: Rt spike pops shock at about 2.5M.

h. Corrective Action: Rerigged R/H spike 1" fwd.

6. Flight #5, 23 June 1964, Flight time 00:27.

a. Discrepancy: The landing gear handle would only go to the neutral position while trying to retract the gear.

b. Corrective Action: Rerigged internal mechanism of gear handle for proper operation. Ground check O.K. per W.O.

c. Discrepancy: U.H.F. was garbled.

d. Corrective Action: Ground check O.K. system sounded good at tower during flight.

7. Flight #6, 24 June 1964, Flight time 00:50.

5  
OXCART

SECRET

- a. Discrepancy: There was a hydraulic leak in the left brake.
- b. Corrective Action: Replaced union, cleaned "B" nut. Pressure check O.K.
- c. Discrepancy: The right engine stalled at approx 2:35M.
- d. Corrective Action: Replaced AIC.
- e. Discrepancy: The "A" yaw channel was lost in flight and would not reset.
- f. Corrective Action: Checked rudder XFR valves FB's and associated wiring to S.A.S. Unable to duplicate failure on ground.
- g. Discrepancy: When the elevons are level the roll trim indicator shows approx 1° right roll.
- h. Corrective Action: Checked on 7 day controls pre-flight O.K. recheck next flight.

8. Flight #8, 26 June 1964, flight time 00:47.

- a. Discrepancy: Cockpit temp control is full cold and can not be changed L/H system.
- b. Corrective Action: System ground check O.K. also checked OK on engine run.
- c. Discrepancy: Yaw "M" light came on several times.
- d. Corrective Action: New resistors to be installed when available for this condition.
- e. Discrepancy: No. 2 oxygen system light came during each stall.
- f. Corrective Action: System checked per F.T. and could not duplicate condition.

9. Flight #8, 7 July 1964, flight time 00:29.

- a. Discrepancy: F.C.F. required for engine I/A/W T.O. 1-1-300 to complete inspection.
- b. Corrective Action: Aircraft test flight completed and accepted. Aircraft hereby released for flight 07/07/64 1000.  
Pilot: [REDACTED]

25X1A

c. Discrepancy: Main pressure light came on in A/B. OK in mil.

d. Corrective Action: Replaced generator control and L.H. generator. Made run and all were good.

e. Discrepancy: Cabin air temp indicator is not indicating correct temp.

f. Corrective Action: Discrepancy C/F - Pilot W. Park stated "OK today" which was correct for flight.

10. Flight #9, 7 July 1963 - Flight time 00:49.

a. Discrepancy: Oxygen pressure - #1 95 PSI, #2 69 PSI. Airborne pressure was #1 60 PSI, #2 65 PSI.

b. Corrective Action: Readjusted #1 and #2 oxygen pressure regulators.

c. Discrepancy: A.D.F. points 90° from station.

d. Corrective Action: Removed and replaced A.D.F. receiver.

11. Flight #10, 9 July 1963 - Discrepancies based on pilot critique after accident.

a. Discrepancy: S.A.T. gun disengaged. Would not reset.

b. Discrepancy: Overtemp on I/H engine to 850°C EGT for unknown period of time.

c. Discrepancy: Fuel quantity system went to zero during descent. No. 2 tank also went below zero.

d. Discrepancy: Fueler trim indicator appears inoperative.

E. Maintenance Service Bulletins - Aircraft

1. Total Service Bulletins issued - 83
2. Service Bulletins cancelled or reissued under a new number - 5
3. Total Service Bulletins worked - 39
4. Total Service Bulletins outstanding - 39

<u>DATE ISSUED</u>	<u>NUMBER</u>	<u>REPAIR</u>
11-9-63	395	Replacement of bolts
13-12-63	474	Oil pres. transmitter rep'l



<u>DATE ISSUED</u>	<u>NUMBER</u>	<u>TITLE</u>
23-11-63	462	Switch adj. - Refuel recept't
18-02-64	485	Fillets - Aft of wheel well
18-02-64	523	Fillets - Forward of wheel well
21-02-64	524	Fuel damper installation engine inlet
27-02-64	505	Installation of suit line pressure regulator
28-02-64	533	Seat electrical disconnect replacement
03-03-64	534	Hatch seal ground pressurization
09-03-64	537	Installation - Hinged rudder pedals (Magnesium)
06-03-64	538	Installation - Sensor warning light no. 3 bearing oil scavage pump
18-03-64	529	AFCS modification
18-03-64	530	AFCS modification
24-03-64	531	INS system modification
26-03-64	544	Engine installation and drag chute installation
02-04-64	546	Receptacle - Fuel probe modification
27-03-64	550	DF 203 ADF system
30-03-64	553	Plastic spike serial revision
02-04-64	556	Pitot heat and landing gear pressure switch installation
06-04-64	478	Caution light installation periscope
23-04-64	515	Rudder servo revision
14-05-64	565	Nose wheel steering control moved from control stick trigger to CSC button and hold in circuit provisions added
14-05-64	567	Switch disconnects for electronics ground cooling

~~OXCAR~~ ~~SECRET~~

<u>DATE ISSUED</u>	<u>NUMBER</u>	<u>TITLE</u>
30-04-64	570	Replacement of float on float switch assembly
14-05-64	573	Drag chute mechanism
20-05-64	548	Onion slicer (Engine inlet aux. bypass) hydraulic plumbing installation
27-05-64	578	Correction of S.B. 544
27-05-64	580	Bracket replacement - Bleed air band guide roller
03-06-64	564	Fuel system dump modification
05-06-64	582	Rework engine inlet duct struts
06-06-64	583	Revision - Ship serial req's for S.B. 462
11-06-64	568	Fuel line installation forward heat exchanger
10-06-64	585	Hydraulic pressure indicator - replacement of
10-06-64	586	Shot counter
16-06-64	572	Temperature sensor replacement
23-06-64	588	Installation of oxygen low pressure switch
18-06-64	589	Platform air duct revision
15-06-64	591	Light base installation
18-06-64	595	Engine inlet by-pass actuator assembly (AF 839)

F. Outstanding Service Bulletins - Engines

1. All outstanding engine service bulletins were classified as "routine" and scheduled for completion at next engine overhaul.

G. Outstanding Service Bulletin - Stability Augmentation System

<u>DATE ISSUED</u>	<u>NUMBER</u>	<u>TITLE</u>
19-6-64	E.O.179J-3	Actuator replacement

~~OXCAR~~

<u>DATE ISSUED</u>	<u>NUMBER</u>	<u>TITLE</u>
1-7-64	E.O.179J-4	Addition of resistors
1-7-64	E.O.179J-5	Ground provisions

H. Findings

1. Inspection and maintenance records were found to be satisfactory.
2. All regular maintenance and inspections had been performed with the exception of compass swing.
3. There were no overdue outstanding manufacturing service bulletins.
4. Unaccomplished manufacturing service bulletins were not a contributing factor to the accident.
5. There were no delayed discrepancies.
6. There is no indication that any known discrepancy or maintenance action was directly related to the cause of the accident.

I. Recommendations

1. None.

  
JOHN R. KELLY, JR  
Lt Col USAF  
Deputy Commander for Materiel

25X1A

  
Inspection Supervisor  
Lockheed Aircraft Corp

25X1A

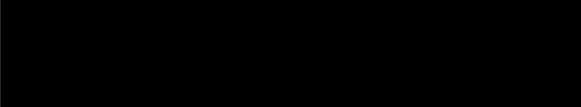
  
Inspection Supervisor  
Lockheed Aircraft Corp

**OXCART**      **SECRET**

AUTOMATIC  
FLIGHT CONTROL  
AND  
AIR DATA SYSTEMS  
GROUP

**OX CART SECRET**

AUTOMATIC FLIGHT CONTROL AND DATA SYSTEMS GROUP

INVESTIGATION OF MAJOR ACCIDENT INVOLVING A-12 AIRCRAFT S/N 133 WHICH OCCURRED AT DET. 1, 1129TH OAS, LAS VEGAS, NEVADA, ON 9 JULY 1964

A. AFCS SYSTEM DESCRIPTION

1. The total AFCS and ADS systems consist of the Stability Augmentation System, the autopilot, the Mach trim system and the air data computer system. (See Figures 1, 2, and 3)

a. Stability Augmentation System (SAS)

(1) The SAS augments the inherent dynamic and static stability of the basic aircraft. It is designed to be ON and operating at all times in flight. Rate gyro and lateral accelerometer signals actuate series hydraulic servos in all three axes which drive the aircraft control surfaces. SAS control movements are not felt at the pilots control stick or pedals. SAS Servo authorities are limited so the pilot can easily override any SAS command.

(2) The pitch and Yaw SAS have triple redundant sensor and electronic channels feeding dual redundant servos. Logic monitor circuits continually monitor system operation and automatically disengage a channel that is malfunctioning. Cockpit warning lights advise the pilot when a channel has been disengaged. Complete augmentation control is retained with any two of the three sensor channels and either one of the two servo channels.

(3) The Roll SAS has dual redundant sensor and servo channels (A and B). Channel A drives the left elevons only and channel B the right. Left and right roll servo tracking is monitored. A failure in either channel automatically disengages both roll SAS channels and lights a cockpit warning light. The pilot may manually select the remaining good channel and continue with full roll SAS gain. There will be some roll to pitch cross coupling since only one set of elevons (right or left) are now operating.

(4) The A and B servos are powered from individual hydraulic systems. Loss of one hydraulic source will reduce the dynamic capabilities of the servos but not below an acceptable level. (Pilot must disengage SAS channels that were operating into the failed hydraulic system in order to restore full gain in Yaw and roll).

(5) The electrical power for the SAS is obtained from three inverters. The power for each SAS sensor and electronic channel is derived from a different inverter. Loss of any single inverter will not significantly impair SAS performance.

(6) A triple redundant air data scheduler automatically schedules SAS signal gains as a function of pitot-static differential ( $q'_c$ ) and static pressure ( $P_s$ ).

**OX CART SECRET**

**OX CART**

(7) The amount of control surface motion commanded by the SAS is limited by the stroke of the series hydraulic servos. The maximum surface displacements available are:

Roll       $\pm 2$  deg. elevon each side (4 deg. differential)

Pitch     +2.5 deg. (up elevon)  
          -6.5 deg. (dn elevon)

Yaw        $\pm 8$  deg. rudder.

(8) The components which comprise the SAS are:

- (a) Function Selector Panel (Pilot's Controls).
- (b) SAS Electronic Components Assembly (ECA).
- (c) Pitch Rate Gyro Package (3 gyros).
- (d) Yaw Rate Gyro Package (3 gyros).
- (e) Roll Rate Gyro Package (2 gyros).
- (f) Lateral Accelerometer Package (3 Accel.)
- (g) Back-up Pitch Rate Gyro (1 gyro).
- (h) SAS Air Data Transducer Scheduler.
- (i) SAS ECA Mounting Racks (2 each).

b. Autopilot

(1) A single channel (non-redundant) autopilot is provided in the pitch and roll axes. Autopilot command signals are summed with SAS signals and operate the SAS series servos. The limited servo authorities also permit the pilot to easily override maximum autopilot commands. Autopilot control modes are:

- (a) Pitch Attitude Hold.
- (b) Roll Attitude Hold.
- (c) Mach Hold.
- (d) Auto-navigation (ties in to INS).
- (e) Pitch attitude command wheel input.
- (f) Roll attitude command wheel input.
- (g) Control Stick Command (CSC).

**OX CART**

(2) All autopilot signals are synchronized to a null level prior to autopilot engagement. Automatic pitch trim keeps the aircraft in trim when the pitch autopilot is engaged.

(3) The roll and pitch autopilots are engaged on the attitude hold modes by individual engage toggle switches on the Function Selector Panel. The other control modes are selected by toggle switches or command input wheels. Control Stick Command mode and autopilot emergency disengage switches are provided on the control stick. The Control Stick Command mode permits manual inputs by removing the autopilot inputs to the series servos without de-energizing the pitch and roll solenoid held engage switches. The roll and pitch trim indicators on the function selector indicate the autopilot bridge error signal prior to engagement.

(4) The control surface movement commanded by the autopilot is limited by redundant electrical limiters to  $\pm 2.4$  deg. elevon for pitch inputs. Roll inputs are limited by the stroke of the series hydraulic servos to  $\pm 2$  deg. elevon each side.

(5) The components which comprise the Autopilot are:

- (a) Autopilot Electronic Components Assembly (ECA)
- (b) All components listed under section (A) above.

c. Mach Trim

(1) The mach trim system provides a pitch trim gradient so as to speed stabilize the vehicle in terms of pilot stick feel. This system automatically corrects a speed instability characteristic of the basic vehicle thru the transonic range. A signal from a Mach No. pickoff Potentiometer in the Air Data Computer drives the pitch trim actuator providing an elevon command proportional to incremental change in Mach number. This artificial gradient forces the pilot to trim nose down for an increase in Mach No. and nose up for a decrease in Mach number. The mach trim system is engaged whenever the pitch autopilot is disengaged. The system is in operation between 0.2 to 1.5 Mach No. The mach trim system is located in the Autopilot ECA.

d. Air Data System

(1) The Air Data System converts the total pressure and static pressure inputs from the aircraft pitot static system into electrical outputs proportional to Altitude, Mach, equivalent airspeed and dynamic pressure ( $q'c$ ).

(2) These outputs are used for:

- (a) Autopilot airspeed error and Mach rate inputs.
- (b) Autopilot airspeed scheduling.

**SECRET**

- (c) Mach trim system input.
  - (d) Inertial navigation system (altitude encoder output).
  - (e) Manual control system authority warning light (warns pilot to switch rudder and aileron authorities at 0.5 Mach No.).
- (3) The system provides a digital readout of Mach, FAS, and altitude on the pilots Triple Display Indicator.
- (4) The Air Data System is comprised of the following components:
- (a) Air Data Computer.
  - (b) Triple Display Indicator.

**B. INVESTIGATION AND ANALYSIS:**

**1. History of AFCS Operation Prior to Accident**

a. The AFCS installed in vehicle No. 133 was utilized on all flights. During the 8 hours total flight time on this aircraft there were no flight squawks reported on the Autopilot, Mach trim or Air Data Systems.

b. The automatic SAS monitor system detected one verified and three non-verified Yaw axis malfunctions on 4 previous flights. Analysis of the non-verified malfunctions seem to indicate the trouble occurred in the Yaw servos or its associated wiring. In all cases, the offending channel was automatically disengaged and Yaw stability augmentation continued satisfactorily on the remaining channels. Voltage transients resulted in Yaw-M channel warning lights on 2 flights; the lights were manually recycled satisfactorily in both cases. A filter capacitor was added to the Yaw-M logic warning light circuit after flight #7 to reduce these voltage transient effects. The Yaw-M warning lights did not recur on subsequent flights.

c. There were no reported Pitch or Roll SAS malfunctions.

d. All flight squawks, the analysis and action taken are tabulated below:

<u>FLIGHT NO.</u>	<u>SQUAWK</u>	<u>ANALYSIS ACTION TAKEN</u>
1	None	-----
2	None	-----
3	None	-----
4	Yaw-M lite Yaw-B lite	Voltage Trans. No Action Broken wire in Yaw B <sub>R</sub> servo feedback. Repaired.

**OXCAR**

**SECRET**



<u>FLIGHT NO.</u>	<u>SQUAWK</u>	<u>ANALYSIS ACTION TAKEN</u>
5	None	-----
6	Yaw-A lite plus vehicle transients	Possible intermittent transfer valve malfunction, could not isolate. Subsequent preflight OK.
7	Yaw-M lite	Voltage transient. Added Capacitor to monitor lite circuit.
8	None	-----
9	Yaw-A lite	Possible servo transfer valve, but condition not isolated. Ran hot oil check. Replaced A <sub>R</sub> Transfer valve.
10	Yaw-A lite	

e. The Yaw-M lite that occurred on flights No. 4 and 7 left a fully operational Yaw axis with redundant A and B channels. The analysis of the problem indicated that a voltage transient caused inadvertent operation of a transistor in the monitor lite circuitry. A capacitor was added to eliminate the effect of this voltage transient. Yaw-A and B Lites on flights 4, 6, 9, and 10 indicated in each case a possible malfunction of servo feedback transducers, transfer valves or the wiring to these components. When the loss of signal from the feedback transducers is detected, the servo channel automatically disengages without aircraft transients. Improper operation of the servo transfer valve due to electrical malfunction or mechanical breakdown usually results in an aircraft transient since the servo must move before the SAS monitor circuitry detects the malfunction and disengages the channel.

f. Prior to flight No. 10, the AFCS was checked and a satisfactory preflight performed. The hot oil check of the servo system did not isolate the servo malfunction indicated on the prior flight. Yaw-A<sub>R</sub> transfer valve was replaced because the current was unbalanced (null offset was within specification however). Yaw-A<sub>R</sub> transfer valve currents balanced satisfactorily after replacing the transfer valve.

2. AFCS Operation During Flight No. 10.

a. The stability augmentation system, Mach trim, and the air data system were in operation during the entire flight. The pilot stated that throughout the flight he did not engage the autopilot.

b. At 2.8 Mach No. the Yaw-A O/S light came on simultaneously with expelling the shock from the left engine inlet. The pilot attempted to recycle Yaw-A several times without success. With each recycle attempt an aircraft Yaw transient was felt by the pilot. This indicated that the

OXCAR

5  
SECRET

malfunction was in one of the transfer valves or in wiring to the valves.

c. The pilot reported that the Yaw-B channel remained in operation and provided satisfactory Yaw control throughout the flight. The pilot also stated that the Yaw-B light did not come on in flight which also indicated normal operation.

d. The pilot reported that all Pitch and Roll SAS channels remained ON and operated normally throughout the flight.

3. Components Installed on Final Flight

a. The AFCS and ADS components installed in vehicle No. 133 at the time of the accident are listed below:

<u>Nomenclature</u>	<u>Part No.</u>	<u>Serial No.</u>
Function Selector Panel	DCG120J2	F-2/J1
SAS Electronic Components Assembly	GBG179J2	F-1/J1
Autopilot Electronic components Assembly	DBG178J1	G-4
Pitch Rate Gyro Package	DGG254A1	G-6
Roll Rate Gyro Package	DGG255A1	G-7
Yaw Rate Gyro Package	DGG256A1	G-7
Lateral Accelerometer Package	DGG157A1	G-7
Back-up Pitch Rate Gyro	GG79A30	G-7
Transducer Scheduler	DLG55A1B	G-2
Air Data Computer	DHG72A3	H-7/A2B
Triple Display Indicator	GJG245B1A	G-3
Mounting Racks (2)(SAS ECA)	DWG205A1A	G-9 & G-10

4. Condition of Recovered Components

a. The major remains of all system components were recovered. They were scattered over an area measuring several hundred feet along the direction of the aircraft travel after impact. The condition of each component when recovered was as follows:

(1) Function Selector Panel (Photo 4799)

(a) Badly damaged by fire and impact. Back cover torn off. Some of the toggle switches were bent, but all were moveable. Switch guards were sheared off and/or melted by fire. Roll and pitch attitude trim wheels were jammed.

(b) All autopilot switches were OFF as would be normal during landing. Pitch-A and Yaw-B SAS switches were ON; all other SAS switches were OFF. The pilot stated that all SAS switches were ON prior to impact as would be normal.

(c) Examination of the SAS channel disengage warning lamp filaments by the Electrical Group indicated that the Yaw-A lamp was illuminated and the Yaw-B, Yaw-M, Pitch-M and Roll monitor lamps were OUT at time of impact. Pitch-A and Pitch-B lamps were missing. This analysis agrees with the lamp conditions described by the pilot.

(2) SAS Electronic Components Assembly

(a) Severe impact damage with some fire damage to the right end of the chassis. The front cover was off and dangling by the back-up Pitch Rate Gyro wire harness. All plug-in cards were missing from the chassis. Sixty four of a total of 74 plug-in cards from the combined SAS and autopilot were recovered. Most cards suffered impact damage but no apparent fire damage.

(b) The gain adjustment potentiometer panel was recovered intact (Photo 4643). The pot settings were all within design tolerances.

(c) All damage appeared to result from the impact and subsequent fire. No obvious evidence of malfunction prior to impact.

(3) Autopilot Electronic Components Assembly

(a) The chassis was torn loose from its mounting brackets on the SAS ECA and split open. All plug-in electronic cards were missing from the chassis. No apparent fire damage (device was found some distance from the fire area).

(b) Impact damage was so severe as to preclude detailed investigation.

(4) Pitch Rate Gyro Package (Photos 4691, 4692 & 4694)

(a) The entire housing assembly containing the Pitch and Yaw Rate Gyro packages was torn from the vehicle structure, and suffered very little damage. The cover door was intact and securely fastened down. Two wires were broken in the aircraft cable connector for the Pitch-M gyro; one was the gyro heater excitation and the other the spin motor excitation. It is probable the wires were broken at impact since the Pitch-M warning light was not reported illuminated in flight. All other aircraft cable wires were intact from the gyro connectors to the point where the wire harness was sheared at impact.

(b) All three pitch gyros were operable. The null output signal scale factors (volts/degree per second) were reasonably linear, although out of Spec.

(c) All three pitch rate gyros were probably operating normally at impact.

OXCAR

**SECRET**

(5) Yaw Rate Gyro Package (Photos 4691, 4692 & 4694)

(a) The base casting was cracked at one mounting point. No fire damage was evident. All gyros were operable. The null signal output voltages were high. The output signal scale factor was linear and very close to design nominal (.140 volts/degree per second).

(b) All three Yaw Rate Gyros were probably operating normally at impact.

(6) Roll Rate Gyro Package (Photos 4688 & 4693)

(a) The cover was torn off and the gyro mounting casting broken. No fire damage was evident. The Roll-A gyro wire harness was intact with no broken wires but the package connector was deformed. The Roll-B wire harness and connector were torn loose at the gyro; parts of 4 wires remained attached to the gyro.

(b) Both gyros were intact. Internal electrical continuity was complete on both gyros. Roll-A gyro would not operate. Roll-B gyro turned over but very rough and slow. There was no signal output.

(c) Damage was too severe to conclude anything about gyro operation prior to impact.

(7) Lateral Accelerometer Package (Photos 4689 & 4690)

(a) Package was relatively intact but with severe impact damage. Package was torn loose from snock mount assembly - all wire harnesses sheared off at connectors by impact. No apparent fire damage.

(b) All three accelerometers were operable and their output signals appeared to track each other normally.

(c) There is no evidence of accelerometer malfunction at time of impact.

(8) Back-up Pitch Rate Gyro

(a) Disintegrated at impact. Only the gyro rotor was recovered. Scratch marks on the rotor indicate it was spinning at impact. No apparent fire damage.

(b) Cannot evaluate performance at time of impact.

(9) SAS Transducer - Pitch Scheduler (a<sub>c</sub> and P<sub>s</sub>)

(a) Relatively intact but with severe impact and fire damage. All wire harnesses and connectors were intact but the wiring was badly burned. Impossible to make continuity checks.

**SECRET**

**OXCART**

**SECRET**

(b) Damage to be reviewed for evaluation.

(10) Air Data Computer (Model 4798)

(a) Cover to the Air Data Computer was severely damaged by impact. Wiring connectors and wiring harness sheared off by impact. No apparent fire damage.

(b) An investigation was made to determine the air data computer readouts at time of impact. Conclusions could be drawn from the position of the gear train and the switch actuator arms due to excessive damage.

(c) Voltage measurements were made on the  $q'_{c}$ ,  $P_s$ , and Mach No. potentiometers. The following results:

(1)  $q'_{c}$  indicated approximately 214 KEAS.

(2)  $P_s$  indicated approximately 000 ft.

(3) Mach No. #4 indicated 7230 ft.

(4) Mach No. #1 indicated approximately 0.43 Mach.

(d) Evidence indicates the Air Data Computer was probably operating normally at impact.

(11) Triple Display Indicator (Air Data Read-out Instrument)

(a) Severe damage to the instrument face and digital read-out dials missing. No apparent fire damage.

(b) Impact damage to be reviewed for evaluation.

(12) SAS ECA Mounting Racks (2)

(a) Both racks were still attached to the SAS ECA. The entire assembly had been torn from the structure at the shock mounts. No apparent damage to racks. The racks operated freely.

(13) The Yaw-A Transfer Valves (Left and right)

(a) Valves were checked for continuity. No malfunctions of internal wiring were noted. Resistances were within the required spec. No continuity check could be performed on the SAS feedback transducers due to excessive damage to the crash (all plugs were pulled out of the transducers). The engage solenoid on the right Yaw transfer valve had the tube carrying the wires from the plug severed but continuity in both directions from the cut tube was satisfactory.

(b) Mounting racks appeared normal.

C. FINDINGS

1. A malfunction occurred in the Yaw-A servo channel when the left engine inlet shock was expelled at Mach 2.85. Yaw-A channel was automatically disengaged. Yaw SAS operation was normal on the remaining Yaw-B servo channel throughout the remainder of the flight. There is no evidence that the Yaw SAS contributed to the accident.

2. Roll SAS operation was normal throughout the flight.

3. Pitch SAS operation was normal throughout the flight.

4. Autopilot was not used.

5. Mach trim operation was essentially normal through out the flight.

6. There is no evidence of Air Data System malfunction during the flight.

7. The Automatic Flight Control and Air Data Systems did not contribute to the accident.

D. RECOMMENDATIONS

None.

25X1A



Division Engineer  
Lockheed Aircraft Corporation

25X1A

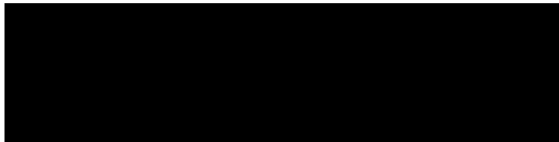

Assistant Project Engineer  
Honeywell

25X1A

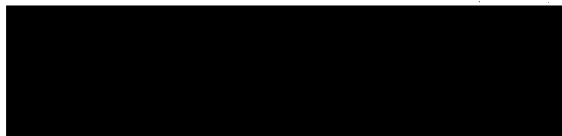

Technical Consultant  
Directorate of Aerospace Safety

25X1A

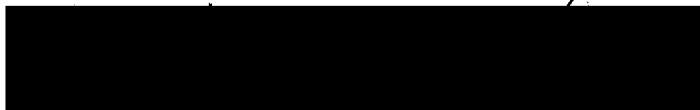

Research Specialist  
Lockheed Aircraft Corporation

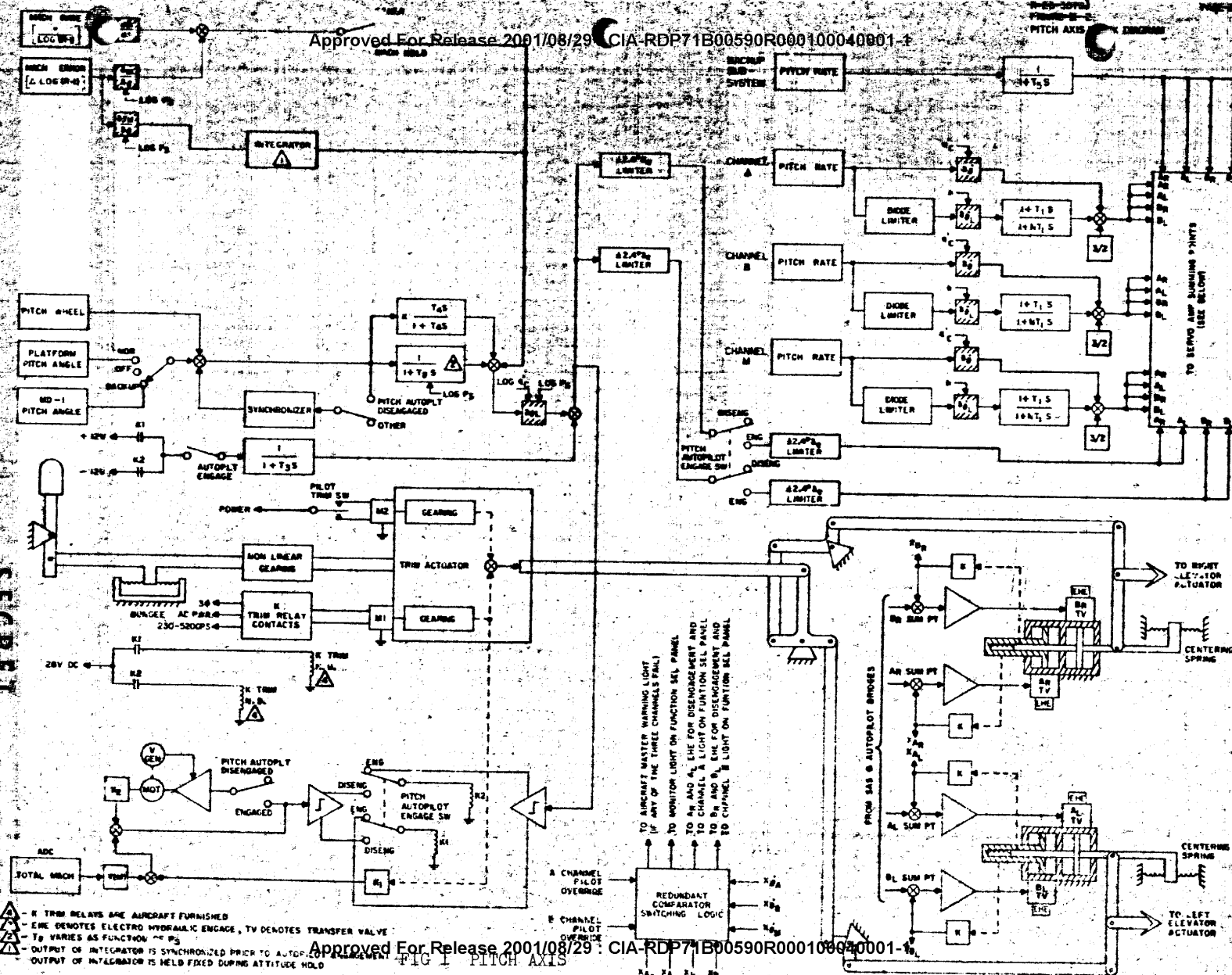

SECRET

FIG 1 PITCH AXIS

A TRIM RELAYS ARE AIRCRAFT FURNISHED  
 EME DENOTES ELECTRO HYDRAULIC ENGAGE, TV DENOTES TRANSFER VALVE  
 TO VARIES AS FUNCTION OF PS  
 OUTPUT OF INTEGRATOR IS SYNCHRONIZED PRIOR TO AUTOPILOT ENGAGEMENT  
 OUTPUT OF INTEGRATOR IS HELD FIXED DURING ATTITUDE HOLD

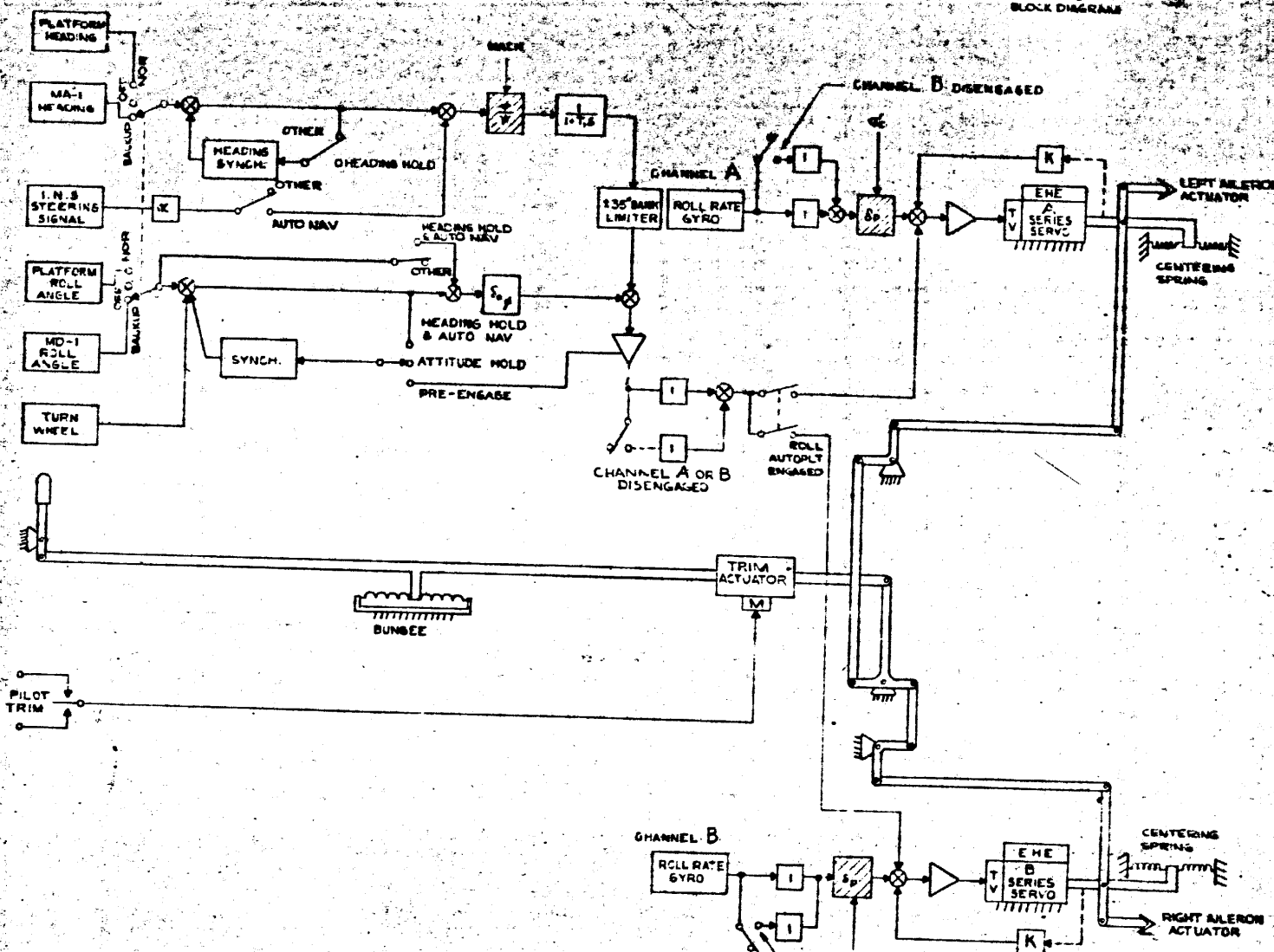

SECRET

1- EHE DENOTES ELECTRO-HYDRAULIC ENGAGE  
TV DENOTES TRANSFER VALVE

FIG 2 ROLL AXIS



FIGURE 2-5  
YAW AXIS  
BLOCK DIAGRAM

Approved For Release 2001/08/29 : CIA-RDP71B00590R000100040001-1

PILOT OVERRIDE PILOT OVERRIDE

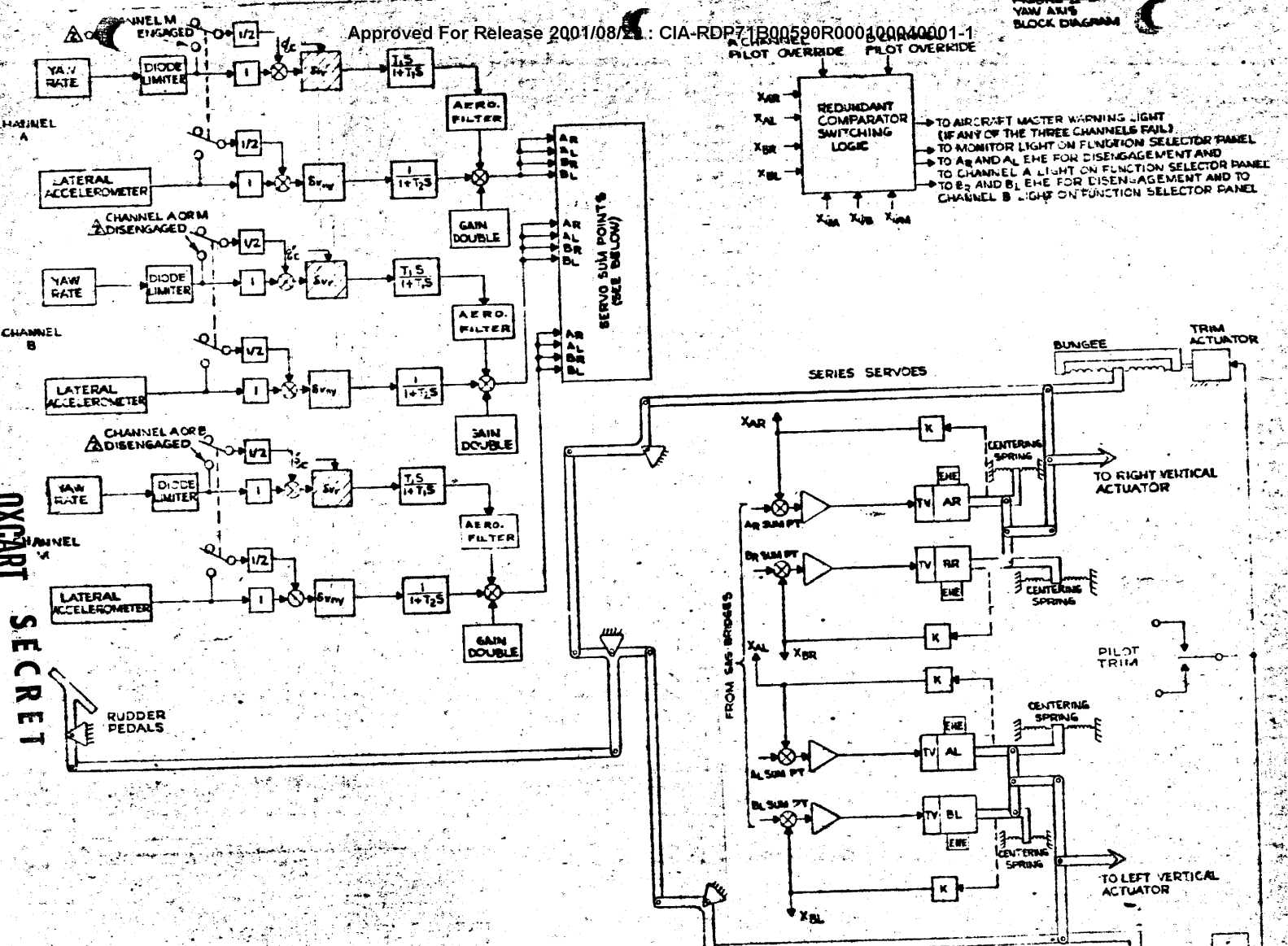

REDUNDANT COMPARATOR SWITCHING LOGIC

- TO AIRCRAFT MASTER WARNING LIGHT (IF ANY OF THE THREE CHANNELS FAIL)
- TO MONITOR LIGHT ON FUNCTION SELECTOR PANEL TO AR AND AL EHE FOR DISENGAGEMENT AND TO BR AND BL EHE FOR DISENGAGEMENT AND TO CHANNEL B LIGHT ON FUNCTION SELECTOR PANEL

3/2 GAIN SWITCHING IS ACCOMPLISHED WITH SOLID-STATE DEVICES  
 RELAY CKTY SHOWN IS FOR CONVENIENCE ONLY  
 EHE DENOTES ELECTRO-HYDRAULIC ENGAGE  
 TV DENOTES TRANSFER VALVE

SECRET

HYDRAULIC

SYSTEM

GROUP

HYDRAULIC SYSTEM

Investigation of major accident involving A-12 aircraft S/N 133 which occurred at Det. 1, Edwards Air Force Base, Las Vegas, Nevada on 9 July 1964.

A. System Description:

1. There are four hydraulic systems installed on the A-12 airplane to provide power to various hydraulically actuated units. Under all normal operating conditions the systems are independent of each other. Each system is a closed center system providing 3350 psi. Each system is served by its own engine driven, fixed angle, variable volume, piston type pump.

2. The "A" hydraulic system provides power to two rudder cylinders, seven outboard elevator cylinders and three inboard elevator cylinders (see Figure #1).

3. The "B" hydraulic system provides power to the two remaining rudder cylinders, the seven remaining outboard elevator cylinders and the three remaining inboard elevator cylinders.

4. The "A" & "B" hydraulic systems have a common reserve oil tank feed into the reserve system by lines feeding "A" & "B" hydraulic pumps. A series of check valves in this oil in reserve until the pilot elects to use either system. In the event the "A" or "B" hydraulic system (surface control system) loses pressure, there will be intersystem leakage from the pressurized hydraulic system to the unpressurized reserve system through the surface control servos. This reserve oil is used to replace the oil lost through the servos.

5. The "L" hydraulic system provides power to the left engine air inlet control, the landing gear (including uplocks and door cylinders), brakes, refueling probe door and probe latch cylinders, UHF antenna cylinder and nose landing gear control (see Figure #2).

6. The "R" hydraulic system provides power to the right engine air inlet control, to the landing gear for emergency gear retraction when the "L" hydraulic system has failed and to the brakes for emergency operation when a loss of "L" hydraulic system pressure has occurred.

7. The hydraulic fluid used on the A-12 aircraft is a highly refined petroleum base oil for use throughout the temperature range of  $-30^{\circ}$  to  $+350^{\circ}$ F. It is referred to as SH-302 hydraulic oil, high temperature. It contains an anti-wear additive, Tricresyl Phosphate (TCP) and an oxidation inhibitor, Ethyl 702. The fluid has a maximum pour point of  $-75^{\circ}$  and a maximum flash point of  $380^{\circ}$ F.

**OXGART SECRET**

OXCAIT

B. Investigation and Analysis

1. The majority of the hydraulic components, with the exception of the surface control servo, were recovered intact, suffered crash damage or were widely scattered with the plane wreckage. Dirt was blown at the tube nut adjacent to the components; in some cases these openings were filled with dirt.

2. The four main hydraulic system pumps were recovered intact. The "L" and "A" pumps were still attached to the left Remote Gear Box along with the generator (photo 4615). The "R" pump was also still attached to the right Remote Gear Box along with the generator (photo 4616). The "B" pump was removed from the right Remote Gear Box with the gear box sustainer. The gear box sustainer around the pump mounting pad. The four pumps were found in an inverted position putting the pump case drain ports toward the ground; most of the oil had drained from the cases as evidenced by the oil-soaked ground directly beneath each pump. All hydraulic plumbing was broken at or near the tube nuts adjacent to the pumps. The tube nut openings pretty well filled with dirt.

a. The "B" hydraulic pump had only surface scratches on the body. The pump was returned to the hydraulic laboratory, cleaned and flushed without disassembly. The pump was completely functional—tested per the new-pump test procedure and performed all tests satisfactorily, including the hot test at 5500 RPM.

b. The "A" hydraulic pump had only surface scratches on the body. The pump was returned to the hydraulic laboratory, cleaned, and flushed without disassembly. The torque to turn the drive shaft was within specification allowable; however, a slight grittiness in turning was noted. It was felt that additional flushing would be required or perhaps disassembly for more thorough cleaning. The pump still appeared operable.

c. The "L" & "R" hydraulic pumps had only surface scratches on the bodies and after cleaning appeared the same as the "A" & "B" pumps. No further tests were made but these pumps also appeared operable.

3. Main Hydraulic System Filters: All eight main system filters were recovered. Examination showed little physical damage, except the "B" return filter bowl was dented causing a small puncture. Photographs noted show the condition of the filters and the attached parts the way they were found at the crash scene.

- a. "A" System - Pressure\* (Photo 4674)
- b. "A" System - Return (Photo 4642)
- c. "B" System - Pressure\* (Photo 4642)

\*Pressure filter in picture is labeled - "A" should be "B" Pressure.

OXCAIT

SECRET

**SECRET**

d. Following are the sizes of the checkout carts (Gig #13 & #16) and the high temperature cart that was used on Article 133 just prior to the accident.

	TABLE OF PARTICULATE CHECKOUT CARTS				
	Sizes 5-14	Sizes 15-49	Sizes 50-99	Sizes Over 100	
(Allowable)	(15000)	(1500)	(150)	(50)	
Gig #13 (P1)	3080	117	9	10	
Gig #13 (P2)	845	117	7	5	
Gig #16 (P1)	799	117	18	16	
Gig #16 (P2)	16909	117	6	6	
Gig #16 (R1)	1199	117	7	5	
Gig #16 (R2)	33219	117	28	6	
Hi-Temp Cart (Pressure Pump)	4242		57	11	
Hi-Temp Cart (Reservoir)	15920		9	7	

e. Following the accident, a check was made of the contamination level of the hydraulic oil in the aircraft. Except those airplanes whose hydraulic systems were depressurized for previously scheduled work. The following table shows the results of this check which is also probably representative of contamination levels in airplane 133 at the time of the accident.

AIRPLANE HYD.		PARTICULATE COUNT				
S/N	SYST.	5-14	15-49	25-49	50-99	OVER 100
121	A RET.	OPEN				
121	B "	"				
122	A RET.	1,348	400	93	17	0
122	B "	OPEN				
124	A RET.	OPEN				
124	B "	"				
125	A RET.					
125	B "	7,849	6,770	888	117	42
126	A RET.	12,750	1,270	106	17	4
126	B "	310	510	168	122	6
127	A RET.	OPEN				
127	B "	OPEN				

**SECRET**

- d. "B" System - Rele (Photo 462)
- e. "L" System - Pr (Photo 463)
- f. "L" System - Rele (Photo 464)
- g. "R" System - Pr (Photo 465)
- h. "R" System - Rele (Photo 466)

Little oil was found in the filter bowls; only short pieces of tubing were still attached to the filter body and these openings were quite dirty. The "A" System filter was still attached to a good size piece of the left hand side with several feet of plumbing still in place, but even this filter contained a small amount of oil in it. Particle count for contamination of residue in the filter bowls could not be made due to insufficient quantity and an amount of sand. Visual inspection of the elements showed no excessive oil that would have restricted flow of oil through the elements.

4. Oil Reserve Tank: (Photo 467)

Tank was badly dented and had several fractured places in the side. Very little oil was in the tank at the crash site; the ground underneath the tank was oil-soaked indicating the tank had oil at the time of impact.

5. Hydraulic Oil Cleanliness

a. Considering the critical nature of the slide-type valves of the hydraulic system, particularly the surface control servos, particle contamination was considered very important. Considerable precaution is taken to assure clean oil.

b. Following are the limits of contamination considered to be acceptable for this hydraulic system and related ground equipment.

CONTAMINATION LIMITS (Particles per 100 cc Sample)

Particle Size	Oil As Purchased (AP-302)	Checkout	Aircraft
	Filtering and Conditioning	Cart	
5-14	10,000	15,000	20,000
15-24	4,000	6,000	8,000
25-49	1,000	1,500	2,000
50-99	100	150	200
100-299	50	50	50

c. Method of Control: Determination of particle contamination by the particle count method is based on Aeronautical Recommended Practice, ARP598, Society of Automotive Engineers, Inc.

OXCAPT SECRET

128	A RET.	530	10	13	3	0
128	B "	4,300	10	92	22	13
129	A RET.	9,800	1,000	800	287	32
129	B "	8,828	1,000	120	31	11
130	A RET.	9,400	1,000	151	29	16
130	B "	31,050	1,000	150	85	28
131	A RET.	23,200	1,000	171	33	6
131	B "	5,888	1,000	170	39	5
132	A RET.	12,250	1,000	260	40	20
132	B "	18,050	1,000	210	287	97
(AIRCRAFT LIMIT)		30,000	1,000	2,000	200	50

C. Findings:

1. Considering the importance of oil cleanliness, a great deal of effort was devoted to determining the probable contamination level of the oil in aircraft 133. This was done after the accident the ground checkout carts #13 & #16, and the high temperature checkout cart that were last used on aircraft 133 were pulled out of service and the contamination levels of these were determined. These levels would be indicative of the oil condition in aircraft 133. The contamination levels, as determined, were acceptable.

2. Let-down from altitude to beginning of final approach appeared to be normal; the landing gear was down; the engine inlet control actuators were extended; the "L" and "R" low pressure gages were not reported as low. There is no evidence to show that the "L" and "R" hydraulic systems contributed to the accident, either by malfunction or loss of the "L" or "R" hydraulic system.

3. The "A" and "B" hydraulic systems are the power sources for the surface control servos. Let-down from altitude to final approach appeared to be normal; the "A" and "B" low pressure lights were not reported "on". The surface control servos are designed so that either hydraulic system can power the control surfaces. Oil cleanliness is assumed to be acceptable up to the servo valve filters. There is no evidence to show that the "A" or "B" main hydraulic system contributed to the accident, even if one hydraulic system had gone out at the last moment.

~~SECRET~~

D. Recommendations: None.

25X1A

25X1A



Technical Advisor  
Norton AFB, California



Hydraulic Engineer  
Lockheed Aircraft Corp.

25X1A



Lockheed Aircraft Corp.

~~SECRET~~





OXGART SECRET

OXGART SECRET

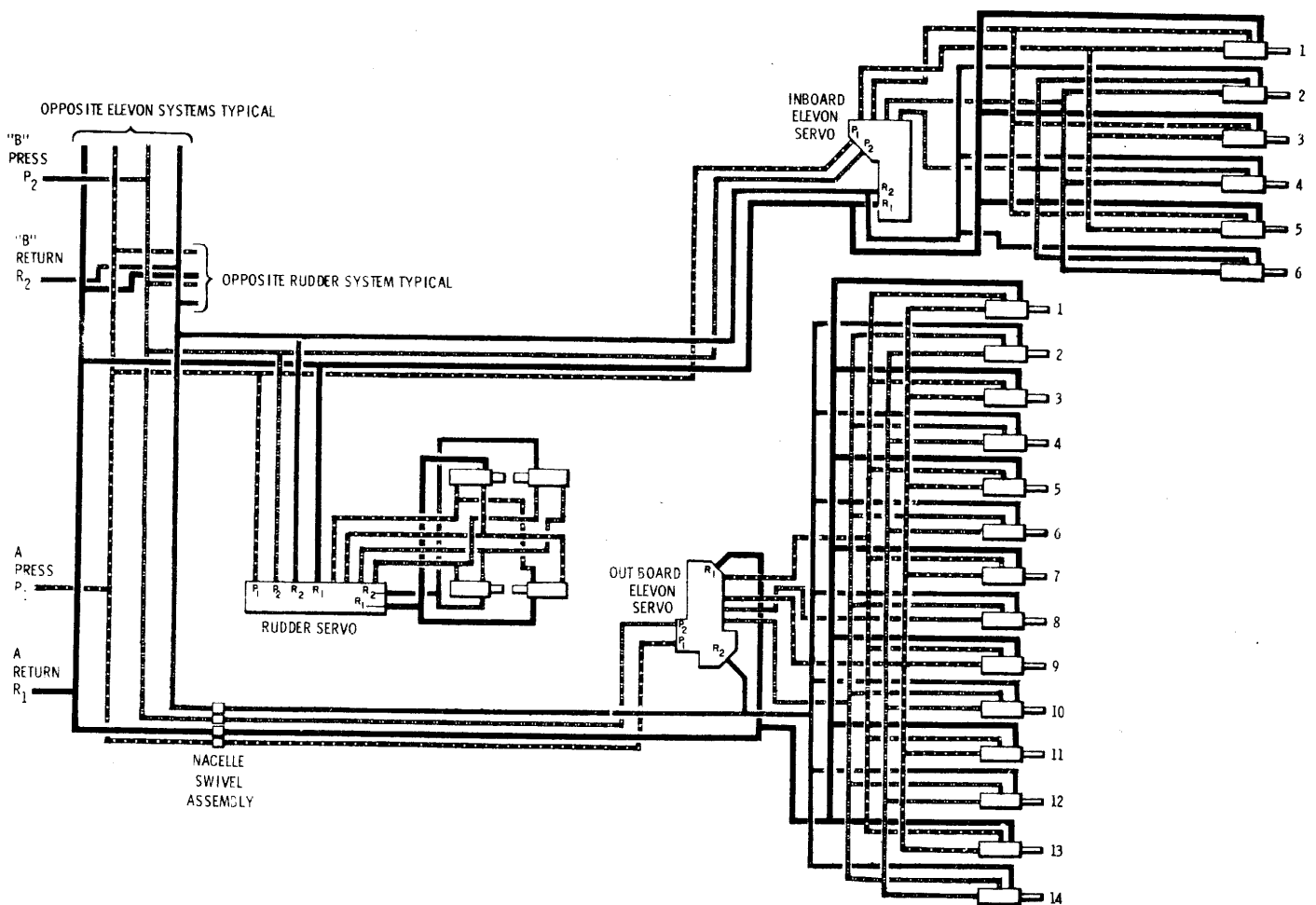

MA12-2-3-5(2)

Figure -1. "A" and "B" Hydraulic Systems Schematic.

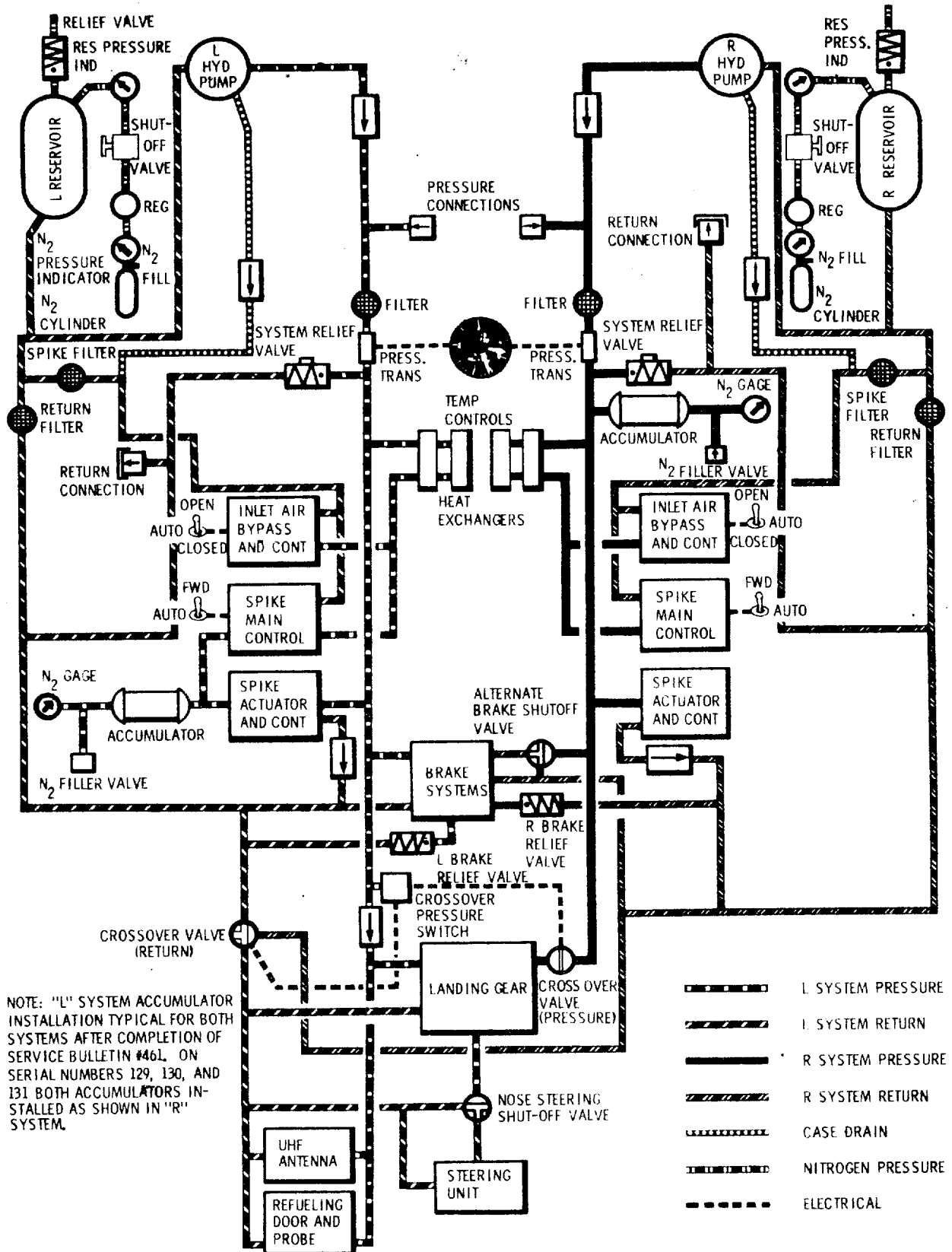

NOTE: "L" SYSTEM ACCUMULATOR INSTALLATION TYPICAL FOR BOTH SYSTEMS AFTER COMPLETION OF SERVICE BULLETIN #46L, ON SERIAL NUMBERS 129, 130, AND 131 BOTH ACCUMULATORS INSTALLED AS SHOWN IN "R" SYSTEM.

- L SYSTEM PRESSURE
- - - L SYSTEM RETURN
- R SYSTEM PRESSURE
- - - R SYSTEM RETURN
- ..... CASE DRAIN
- ..... NITROGEN PRESSURE
- ..... ELECTRICAL

FLIGHT CONTROL

SYSTEM

GROUP

**OX CART SECRET**  
**FLIGHT CONTROL SYSTEMS**

	<u>PAGE</u>
A. THROTTLE	1
B. RUDDER	2
C. ELEVON	6
D. SERVO CONTROL	12
E. FLIGHT CONTROL SYSTEMS AND ANALYSIS	18
F. RECOMMENDATIONS AND ACTION TAKEN	27

**OX CART SECRET**

## **OX CART SECRET**

### FLIGHT CONTROL SYSTEMS

Investigation of major accident involving A-12 Aircraft, S/N 133, which occurred at Det 1, 1129th, Las Vegas, Nevada on 9 July 1964.

#### A. AIRCRAFT THROTTLE CONTROL SYSTEM

##### 1. System Description.

a. The aircraft throttle control system originates in the cockpit throttle quadrant assembly which is located in the left hand side console. This assembly contains two cable tension regulators attached to the pilot's throttle levers. This assembly includes a third lever used to vary the throttle system friction and also includes the landing gear warning switch. The cables are attached to the tension regulators and form a single closed loop system for each engine. The cables are routed from the cockpit through the fuselage out the main gear wheel wells to the nacelle where they terminate on a cable quadrant. This quadrant is attached to a torque tube which actuates the engine fuel control valve, crank and pushrod linkage.

##### 2. Investigation and Findings.

a. Throttle Control from the cockpit to the terminal pulleys.

(1) The cockpit throttle quadrant was extensively damaged at the time of impact. All supporting structure attached to the aircraft was torn loose. The basic components although damaged were in a condition that they could be examined. (See photo 1-4602)

(2) The cockpit throttle lever for the left hand engine was broken at the top cover of the quadrant. It was not found. The lower section of the lever was intact and was in the idle position. The cockpit throttle lever for the right hand engine was intact, but bent inboard 45 degrees. The lever setting was approximately 10 degrees forward of the military power range. The cable tension regulators were intact although they were twisted and distorted. The basic springs in the regulators were not broken and were secured in place. All components of the unit were bolted and secured in place. The throttle cables which attach to the tension regulators were found detached from the regulators. All cable ball fittings were securely attached. The cable pulley bracket which routes the cables down the fuselage through the cockpit was damaged. The brackets were intact but the metal structure was bent and twisted. Two of the four pulleys were broken.

(3) The throttle cables are routed with the elevon and rudder cables aft from the cockpit using the same pulley bracket clusters to the main gear wheel well. The damage to the pulley brackets and the cables are described in the elevon system investigation.

(4) At the main gear wheel well bracket, the cables are routed outboard to a terminal pulley bracket attached to the forward side of the wing beam. The pulley brackets on both LH and RH side were found

## **OX CART SECRET**

**OXCART SECRET**

to be damaged. Both LH and RH brackets were broken at the terminal pulley. All cable ends were found secured in place at the terminal pulleys on LH and RH side. Both the LH and RH cables had failed about 36 inches from the terminal pulleys. The type failure was due to an overload condition. This was evidenced as the cable ends were torn at different lengths and the cable strands unwound in a snap-back manner.

b. Investigation of LH throttle linkage from terminal pulley to LH engine fuel control unit.

(1) The torque tube to which the terminal pulley is attached has a bend in the center upward about 3 degrees. The crank end of the torque tube was broken at the tube. The pushrod from the torque tube crank to the engine crank has a 30 degree bend in it about 4 inches from the engine crank. Both ends of the pushrod were bolted and secured to the crank ends. The engine bell crank was not damaged but the fuel control shaft was broken 2 inches from the crank end. The two serrated washers between the crank and fuel control unit were on the fuel control shaft and engine crank. The tie rod from torque tube to engine was not found.

c. Investigation of RH throttle linkage from terminal pulley to RH engine fuel control.

(1) The torque tube to which the terminal pulley is attached has two bends about 8 inches apart at a 10 degree angle with each other. The bend starts about 14 inches from the terminal pulley. The torque tube was broken 6 inches aft of the terminal pulley. The crank end of the torque tube was bolted and secured to the tube showing no damage. The pushrod from the torque tube to the engine crank has a 30 degree bend in it about starting at the crank end. Both ends of the pushrod were bolted securely to the crank ends. Both rod end bearings were bent at the threads. The engine bell crank was twisted and bent, and had separated from the fuel control unit. The tie rod from torque tube to engine was not found.

### 3. Findings.

The described damage to the throttle control system was the result of crash impact. The system was operational and structurally airworthy prior to the mishap.

## B. RUDDER SYSTEM.

### 1. System description.

a. The pilot input to the rudder servos is taken from conventional rudder pedals through tension rods to a cable tension regulator in the cockpit. From the cable tension regulator the motion is transmitted through two closed loop cable systems, one for each rudder, to a terminal quadrant in each wing just inboard of the nacelle.

**OXCART SECRET**

**OXGART SECRET**

From these terminal quadrants, motion is transmitted through torque shafts and pushrods to the servo input levers in the fins. The trim actuators which include the feel springs and trim position transmitters are connected in parallel to the pilot. The rudder trim and feel spring assembly is supported so that all its loads are reacted through a shear pin. In the event the trim actuator should seize, the resistance from that actuator is removed by applying sufficient rudder pedal force. Motion from the pilot or the trim actuator is transmitted from the servo input lever into the rudder servo package. This motion is then carried through levers and rods to the dual hydraulic control valve which controls the direction and rate of the surface actuating cylinder. There are two cylinders on hydraulic system "A" and two cylinders on hydraulic system "B" for each rudder. From the actuating cylinder the motion is transmitted through an intermediate crank and link to the rudder surface. The motion of the intermediate crank is also used to drive the follow-up rod which centers the dual hydraulic control valve when the proper surface position is reached. A second means of surface control, to satisfy the need of stability augmentation is through the dual mod. piston in the servo package. One mod piston is on hydraulic system "A", the other is on hydraulic system "B" and each is controlled by separate electro-hydraulic transfer valves. The electro-hydraulic transfer valves receive electrical control signals from the stability augmentation system. These electrical signals are used to control hydraulic flow to the mod pistons. Motion of the mod pistons is transmitted through linkages to the same dual hydraulic control valve actuated by the pilot or trim actuator. To limit control surface travel for high speed flight there is a pilot operated surface limiter control handle in the cockpit. This handle when in the forward (or on) position restricts the movement of the rudder pedals and cable tension regulator in the cockpit. Movement of the control handle also operates three electrical switches used in the circuits to control the servo surface limiter solenoid valve and the visual warning indication for correct handle position. The rudder limiter stops in the cockpit are mechanically connected to the roll stops on the stick and the same handle operates both. (See figure 1)

## 2. Investigation and Analysis.

### a. Rudder Controls from the Control Stand to the Servo Unit.

(1) The cockpit rudder parts were damaged extensively at the time of impact. The basic components in the control stand, although damaged were in a condition that they could be examined (see pictures 1-4590 and 1-4595).

(2) The left hand rudder pedal was bent and twisted but secured to its structure. The right hand rudder pedal was broken at the point where it attaches to the arm structure. The pedal was bent and twisted. The linkage from the pedal to the cable tension regulator was bent, twisted and the pushrods were broken. The basic attaching bolts for this linkage system was bolted and secured.

**OXGART SECRET**



**OX CART SECRET**

(3) The cable tension regulator was damaged extensively. The elements of the regulator which affect the cable tension of the control system cables were intact. The basic springs in the regulators were not broken and were secured in place. The regulator sectors to which the control cables are attached are twisted and distorted. It is noted that all bolted connections which attach the regulator to the control stand structure are secured in place. The rudder cables which attach to the tension regulator were found in the sectors. The cable end fittings were securely attached to the cables.

(4) The rudder cables are routed with the elevon and throttle cables aft from the cockpit using the same pulley bracket clusters to the main gear wheel well. The damage to the pulley brackets and the cables are described in the elevon system investigation.

(5) At the main gear wheel well bracket, the rudder cables are routed outboard to pulley brackets attached to the wing beam. This pulley bracket also routes the cables aft to a terminal pulley and pushrod linkage in the inner wing. This bracket and pulleys, both left hand and right hand were intact with no apparent damage.

b. Examination of terminal pulley and rudder pushrod linkage to the LH rudder servo, (see pictures 1-4850 and 1-4856).

(1) The cable end fittings were found attached to the pulleys secured in place. The cables failed 5 feet from the cable ends. The cable breaks were due to an overload condition. This was evidenced as the cable ends were torn at different lengths and the cable strands unwound in a snap-back manner. The pulley and torque tube was not damaged, however, the clevis end of the torque tube was slightly twisted. The supporting structure for the torque tube was intact.

(2) The pushrod from the inboard end of the torque tube up to the idler bracket in the nacelle was bent and twisted about 180 degrees. The bend occurred about 12 inches up from the torque tube crank end. Many dents about  $\frac{1}{2}$  inch deep were found. Both ends of the pushrod were bolted and secured to the crank ends. The rod end bearing on the idler crank side was bent about 15 degrees.

(3) The idler crank and supporting structure was bent and twisted. The idler crank was broken at the crank hub end. The attaching bolt from the crank to the crank bracket was secured in place.

(4) The pushrod from the idler crank to the top bell crank was bent about 15 degrees. The rod end bearing on the idler crank side was bent 10 degrees at the threads. Both ends of the pushrod were bolted and secured to the crank ends.

(5) The top bell crank and supporting structure was damaged. The structure was twisted and bent. The upper crank end was broken about 3 inches down from the clevis.

**OX CART SECRET**

## OXGART SECRET

(6) The pushrod from the top bell crank aft to the rudder servo unit was bent and twisted in about five places. The rod end bearing on the top bell crank side was broken at the threads. The pushrod was broken about 4 inches from the aft end. Both ends of the pushrod were bolted and secured to the crank ends.

c. Examination of Terminal Pulley and Rudder Pushrod Linkage to the RH Rudder Servo. (Serial Nos 1-4846 and 1-4586)

(1) The cables and fittings were found attached to the pulleys secured in place. The cables failed 3 feet from the cable ends. The cable breaks were due to an overload condition. This was evidenced as the cable ends were torn at different lengths and the cable strands unwound in a snap-back manner. The inboard end of the torque tube was broken at the offset section of the tube. This inboard end of the torque tube containing the crank was not found.

(2) The pushrod from the outboard end of the torque tube up to the idler bracket in the nacelle was bent about 180 degrees. The tube was flattened over its entire length. The rod end bearing on the torque tube end was not damaged but the attaching bolt had sheared from the torque tube clevis.

(3) The idler crank was broken at the crank hub end. The crank bracket and supporting structure was twisted and bent.

(4) The pushrod from the idler crank to the top bell crank was bent in two places about 10 degrees, 4 inches apart, the first bend starting 2 inches from the idler crank end. The rod end bearing at the idler crank was broken at the threads. Both ends of the pushrod were bolted and secured to the crank ends.

(5) The top bell crank was broken into three pieces. The lower crank end was broken at the crank hub. The upper crank was broken below the clevis end. The supporting structure for the crank was not found.

(6) The pushrod from the top bell crank aft to the rudder servo unit was bent, twisted and flattened over its entire length. The rod end bearing on the top bell crank end was broken at the threads. The bearing portion was not found. The pushrod was broken about 6 inches from the aft end. The aft end of pushrod was bolted and secured to the crank ends.

### 3. Findings.

The described damage to the rudder control system from the cockpit control stand to the terminal pulleys in the inner wing and the mechanical linkages to the rudder servos at the surfaces was the result of crash impact. The system was operational and structurally airworthy prior to the mishap.

## OXGART SECRET

**OXCART SECRET**

## C. ELEVON SYSTEM

## 1. System description.

a. The pilot input for pitch and roll is applied to a conventional stick in the cockpit. From the stick the roll motion is transmitted through a torque tube, crank, and pushrod to the roll cable tension regulator in the cockpit. From the stick the pitch motion is transmitted through pushrods and cranks to the pitch tension regulators in the cockpit. Both the pitch and roll tension regulators are designed to operate also as cable slack absorbers. Motion of pitch and roll tension regulator is transmitted through a dual closed loop cable system which is routed through the fuel tanks inside a tube on each side of the upper fuselage. The cables terminate on a pitch or roll cable quadrant located in the tail cone. From the pitch and roll quadrants the motion is transmitted through torque tubes to the mixer in the tail cone. The mixer is a mechanism of levers and links that uses inputs of pitch or roll motion or combinations of both, and converts them into a single output motion to control the elevon surface position on one side of the airplane. The mixer includes one spring for pitch and one spring for roll which produces the control stick forces felt by the pilot. The mixer has two output rods, one to control L.H. elevons and one to control R.H. elevons. These two mixer output pushrods move independently of each other being controlled by the combination of pitch and roll input position. The mixer contains one electro-mechanical trim actuator for pitch and one electro-mechanical trim actuator for roll. The pitch trim actuator has, in addition to the pilot controlled trim motor, a second lower speed motor controlled by the autopilot or mach trim systems. Either of these motors, through gearing within the actuator, drive the same jack screw which changes the extension or retraction of the actuator. The mixer output rod transmits motion to a crank on the inboard servo package. The follow-up rod from the surface is connected to the same crank but on the opposite side. This crank with the input and follow-up rods on its end is pivoted on another lever that transmits motion into the servo package and through a linkage to the dual hydraulic control valve. The dual hydraulic control valve controls the direction and rate of 6 actuating cylinders on the inboard surfaces, three on hydraulic system "A", and three on hydraulic system "B". A second means of surface control to satisfy the need of stability augmentation and autopilot is through the use of the mod pistons within the inboard servo packages. There are three mod pistons in each inboard package controlled by separate electro-hydraulic transfer valves. Two mod pistons are used for pitch control and one for roll. A more detailed explanation of the operation of the servos can be found in the servo, hydraulic and electronic sections. Motion of the inboard surface is transmitted through a system of pushrods, cranks and torque tubes through the inner wing, under the engine and through the outer wing to the outboard servo input lever. The second pushrod in the inner wing of this transmission system is a preload spring cartridge to protect the transmission system from overload during manufacture and testing as this system is power-driven by the inboard cylinders. Motion at the outboard servo input

**OXCART SECRET**

**OX CART SECRET**

lever is transmitted through linkage into the outboard servo package to the dual hydraulic control valve. Position of this hydraulic control valve controls the direction and rate of the 14 actuating cylinders on the outboard surface, 7 on hydraulic system "A" and 7 on hydraulic system "B". The follow-up rod is connected to the surface and to the outboard servo input lever at the opposite end from the input pushrod and serves to center the dual hydraulic control valve when the proper surface position is reached. The dual hydraulic valve in the outboard servo package includes a bias spring that loads the valve and transmission linkage to eliminate lost motion. In order to keep the outboard surface from going to the full down position in the event of a failure in the transmission, the outboard servo installation includes a spring loaded cartridge set at the 2° down surface position which is capable of over powering the bias spring. To limit elevon roll control surface travel for high speed flight there is a pilot operated surface limiter control handle in the cockpit. This handle when in the forward (or on) position engages a spring loaded stop that limits control stick motion in the roll direction only. Engagement or disengagement of this stop operates electrical switches that are used in the visual warning indication for incorrect handle position. The roll surface limiter stops are connected to the rudder limiter stops mechanically and the same handle operates both (see figures 2 and 9).

## 2. Investigation and Analysis.

a. Elevon Control: From the Cockpit Control Stand to the Mixer in the Tail Cone.

(1) The cockpit control stand parts were damaged extensively at the time of impact. All supporting structure to the aircraft was torn loose. The basic components of the control system, although damaged were in a condition that they could be examined. (See photos 1-4590, 1-4595.)

(2) The pilot control stick was broken in the hand grip section and also broken at the bottom end where it attached to the fore and aft torque tube-pushed linkage. This linkage system which transmits motion to the pitch and roll cable tension regulators was found. All cranks and bolts were found to be secured in place. The pushrods from the linkage to the regulators were broken in the center sections of the pushrods. The rod end bearings on the ends of the pushrods were found secured to the linkage.

(3) The pilot operated surface limiter control handle was found detached from the control stand. The handle was found positioned in the AFT or out position which indicates that full surface travel was available as it should be. (See photo 1-4588.) This position must be accepted as the position prior to impact since the action for engagement for unrestricted surface travel is a two position, aft and then right angled motion which is most improbable to activate to this position as a result of post impact forces.

**OX CART SECRET**

## OXCART SECRET

(4) The pitch and roll cable tension regulators were damaged extensively. The elements of the regulators which affect the cable tension of the control system were intact. The basic springs in the regulators were not broken and were secured in place. The regulator sectors in which the control system cables are attached were twisted and distorted. It is noted that all bolted connections which attach the regulators to the control stand structure were secured in place.

(5) The main cables which attach to the pitch and roll regulators were found in the regulator sectors or adjacent to the units. All cable end fittings were securely attached to the cables. The cable pulley brackets in the control stand which routes the cables outboard and aft from the control stand through the cockpit were intact although some of the pulleys showed fire damage. The cable pulley brackets forward of the nose gear wheel well area on the left hand and right hand side of the ship were bent and twisted due to impact. The cables (elevator, rudder and throttle system) failed in this area. The type of failure was due to an overload condition. This was evidenced as the cable ends were torn at different lengths and the cable strands unwound in a snap-back manner. It was observed that all cable disconnect fittings were secured to the cables. The tubes through the forward fuselage fuel bays from the cockpit to the main gear wheel well in which the cables are routed were found to be broken and twisted. The cables were found inside the tubes and had failed. The type of failure was due to an overload condition. The cable ends were torn and the cable strands unwound. The cable pulley brackets in the main gear wheel well area on both left and right hand side were severely bent and twisted. It was found that all cable turnbarrel connections in this area were connected and intact although bent. The tubes through the aft fuselage fuel bays, from the main gear wheel well to the mixer in which the cables are routed were found to be broken and twisted. The cables were found inside the tubes and had failed. The type of failure was due to an overload condition.

(6) The cable system terminates on the pitch and roll Quadrants at the mixer. It was observed that all cable fitting ends were securely attached to the cables and all cables were securely attached to the mixer quadrants.

b. Elevon Mechanical Transmission System from the Inboard Elevon Surfaces to the Outboard Elevon Surfaces.

(1) The elevon mechanical transmission system from the inboard elevon surface to the outboard elevon surface which consists of pushrods, cranks, and torque tubes through the inner wing and under the engine was scattered into pieces. The pieces were picked up from the crash area and layed out in their proper sequence in the hanger for examination. The complete system was pieced together, both L.H. and R.H. sides were complete although damaged extensively.

## OXCART SECRET

**OXCART SECRET**

(2) Examination of L.H. System. (Refer to elevon system schematic and photos 1-4608, 1-4636 and 1-4851.)

(a) The spring loaded pushrod from inboard servo valve lever to outboard crank on aft side of elevon structure was found in place. Both ends of pushrod were bolted and secured to crank ends. The inboard end of the pushrod has a dent and a 5 degree bend 2.25 inches from the large tube section. The damage was caused by impact. The cylinder in which the spring is inclosed was cut apart longitudinally. The interior was examined in an attempt to determine position of the outboard elevon, however, no definite conclusion could be reached.

(b) The pushrod from crank end on forward side of outboard crank to crank on nacelle beam was found intact. Both ends of pushrod were bolted and secured to crank ends. The crank bracket was intact but had been torn loose from the ship structure.

(c) The fore and aft pushrod from this crank to the next forward idler crank was found intact. Both ends of pushrod were bolted and secured to crank ends.

(d) The next fore and aft pushrod from the idler crank to the crank on the inboard torque tube was found intact. Both ends of pushrod were bolted and secured to crank ends.

(e) The inboard torque tube in the engine nacelle was damaged extensively. The inboard crank arm was bent inboard approximately 15 degrees. The fasteners that attach the tubes to the crank ends were sheared. The outboard crank end of the torque tube was bent outboard 45 degrees.

(f) The short pushrod from the inboard torque tube to the center torque tube was broken at the threaded end of the bearing on the outboard torque tube side. Both pushrod ends were bolted and secured to the torque tube crank ends.

(g) The center torque tube was bent in the center approximately 10 degrees up. It did not appear to be twisted. The inboard crank end was bent and twisted approximately 30 degrees inboard. The outboard crank end was bent outboard at the clevis approximately 45 degrees.

(h) The short pushrod from the center torque tube to the outboard torque tube was not broken but was severely twisted. Both ends of pushrod were bolted and secured to the torque tube crank ends.

(i) The outboard torque tube tubular section was not damaged. The inboard crank end was bent approximately 45 degrees outboard. The outboard crank end was not damaged.

**OXCART SECRET**

**OX CART SECRET**

(j) The fore and aft pushrod from the outboard torque tube to the idler crank on the nacelle structure was intact. Both ends of pushrod were bolted and secured to the crank ends.

(k) The fore and aft pushrod from the idler crank to the outboard servo lever was intact. Both ends of the pushrod were bolted and secured to the crank ends.

(l) The idler crank and supporting structure was not damaged.

(3) Examination of E.H. System. (Refer to elevon system schematic, and photos 1-4848, 1-4852, 1-4854 and 1-4855.)

(a) The spring loaded pushrod from inboard servo valve lever to outboard crank on the aft side of elevon structure was found in place undamaged. Both ends of pushrod were bolted and secured to the crank ends. The cylinder in which the spring is enclosed was cut apart longitudinally. The interior was examined in an attempt to determine position of the outboard elevon, however, no definite conclusion could be reached.

(b) The pushrod from crank end on forward side of outboard crank to crank on nacelle structure was broken. The break occurred at 10 inches aft of forward section. Both ends of pushrod were bolted and secured to crank ends. The crank bracket and supporting structure to ship were not found.

(c) The fore and aft pushrod from this crank to the next forward idler crank was broken in three pieces. The first break occurred at 6 inches forward of aft section of pushrod. The second break occurred at 3 inches aft of forward section of pushrod. Both ends of the pushrod were bolted and secured to crank ends.

(d) The next fore and aft pushrod from the idler crank to the crank on the inboard torque was broken into several pieces. The center section of the round tube approximately 36 inches long was not found. Both ends of the pushrod were bolted and secured to crank ends.

(e) The inboard torque tube in the engine nacelle was damaged extensively. The inboard crank arm was bent and twisted approximately 10 degrees. The fasteners that attach the tube to the crank ends were sheared, separating the unit into three pieces. The center tubular section was bent up 15 degrees and twisted approximately 30 degrees. The outboard crank end was bent approximately 45 degrees. The clevis end of the crank is spread apart, one ear of the clevis part of the crank is bent 45 degrees outboard. The other ear of the clevis is bent inboard approximately 45 degrees.

**OX CART SECRET**

## OX CART SECRET

(f) The short pushrod which attaches to the inboard torque tube clevis was not attached. The inner race of the pushrod bearing was pulled out. The bearing race and bolt connection was not found. It is noted that a severe bending-twisting load caused this failure - to spread the clevis apart and to dislodge the inner race of bearing from the pushrod. The direction of the normal operating forces on this connection is a straight horizontal force. The other end of the short pushrod was found attached to the center torque tube inboard crank end. The bolt was attached and secured to the crank end.

(g) The center torque tube has a heavy dent about 1 inch deep and 6 inches long starting 3 inches from the inboard end. The inboard crank end was bent and twisted approximately 30 degrees. The outboard crank end was bent outboard approximately 45 degrees.

(h) The short pushrod from the center torque tube to the outboard torque tube was bent and broken at the threaded end of the bearing on the center torque tube side. Both pushrod ends were bolted and secured to the torque tube crank ends.

(i) The outboard torque tube was bent up at the center approximately 15 degrees. The inboard crank end was bent inboard approximately 45 degrees. The outboard crank end was broken from the torque tube and found attached to the pushrod with the bolt secured to the clevis end of the crank.

(j) The fore and aft pushrod from the outboard torque tube to the idler crank on the nacelle structure was broken and twisted 10 inches from the forward end. It also was bent and twisted inboard 12 inches from the aft end. Both ends of pushrod were bolted and secured to the clevis ends of the cranks.

(k) The idler crank and supporting structure was intact and attached to the ship. The sheet metal parts were bent.

(l) The fore and aft pushrod from the idler crank to the outboard servo lever was broken 2 inches from the forward end. The rod was also bent in two places about 6 inches apart starting 12 inches from the aft end. Both ends of the pushrod were bolted and secured to the crank ends. The damage to the pushrod was examined in an attempt to determine surface position. The position of the bends caused by hitting structure indicates that the outboard elevon was in a full down position at some time during or after impact.

(m) The idler crank and supporting structure to the ship was not damaged.

### c. Findings.

(1) The described damage to the elevon control system from the cockpit control stand to the mixer in the tail cone, and the mechanical transmission system from the inboard surfaces to the outboard surfaces with the exception of the elevon servo systems was the result of post-crash impact. The system was operational and structurally airworthy prior to the mishap.



**OX CART SECRET**

## D. SERVO CONTROLS

## 1. System description.

a. The flight control surfaces are powered by hydraulic servos operated by 3350 psi pressure at each of the six movable surfaces: two rudders, two inboard elevons and two outboard elevons. All flight direction and stability augmentation is performed by these six servos. All servo power is dual. Each system is supplied by a separate hydraulic pump. Each system has the capability of completing the mission, as each operates independent of the other. Levers and links are dual where possible. Where doubling up is not possible, high margins of safety are used. Most pin joints are dual and are retained in position, in most cases, by two separate and independent methods.

b. The servo valves are of single spool design, with each hydraulic system occupying one half of the spool. The mechanical input signal to the valves is by rotary motion through a carbon-ring seal to an internal lever submerged in return hydraulic fluid under 135 psi pressure.

c. The stability augmentation system (SAS) is dual electro-hydraulic. It is part of each servo valve assembly, except the two outboard surface servos, which receive their SAS signals through mechanical connection to the inboard surfaces. The rudder servos have two electro-hydraulic transfer valves, one on each hydro system ("A" and "B"). The inboard elevons have three valves on each servo. Two valves are paired up for pitch augmentation, one on hydro system "A" and the other on "B". The third valve on left and right servos is for roll augmentation. Single valves on roll are used because adequate roll correction can be made with either right or left hand surface. The transfer valves cause hydraulic flow to move separate modulating pistons and linkage within the servo package. This linkage is submerged in the return oil. Motion of these pistons adds to, or subtracts from, any pilot motion on the internal summing lever. The stroke of these pistons, or of levers, is limited so as to limit the authority of the SAS. Closing of the servo loop around each piston to the transfer valve is accomplished by linear voltage differential transformers (L.V.D.T.). Each mod. piston has one L.V.D.T., except the roll where 2 L.V.D.T.'s are used on each because of the malfunction comparison system. A solenoid operated shutoff and bypass valve, normally in the off or bypass position unless the SAS system is on, form a part of each transfer valve. By comparison of the positions of the modulating (mod) pistons, as sensed by L.V.D.T. for any axis on either hydraulic system, a malfunction from any cause is made to open the circuit of the affected or malfunctioning system. Opening the circuit places the transfer valve in bypass, allowing that mod piston to return to its spring loaded neutral position. The other system is left operating in a normal manner with no loss of control.

d. Because of the design of the rudder servo travel limiters which is only on the rudder system, their position can tell a very definite story. To understand their operation, a detailed description follows:

**OX CART SECRET**

**OX CART SECRET**

The travel limiters, at each rudder servo, are two hydraulic actuated pistons with limited travel. They form stops for the rudder servo summing lever and contact the lever above the follow up link attachment. This position is necessary, first, so that lever contact with the stop is able to shut off the servo valve. Second, its position must be such that it knows the sum of the surface angle instigated by SAS and that added by the pilot. The sum of which are not to exceed  $10^{\circ}$  of surface angle by any combination. The size of these pistons must be such that they cannot be overpowered by the pilot, SAS, or any combination thereof, as long as the limiter handle in the cockpit is pulled out. The design of the cylinder is such that, at all times, the rod end is under full hydraulic pressure, i.e. no valve is in this pressure supply line. The other side of the piston receives its full hydraulic pressure through a normally open solenoid valve of "micro-seal" design. Excitation of the solenoid is necessary for retraction of the cylinder. This opens the large side of the piston to return. Because of the friction exerted by the bar "X" dynamic seals, full hydraulic pressure is usually required on the rod end to retract the stop. The limiters on the left rudder servo are on the "A" hydraulic system, the limiters on the right, on the "B" system. Electrical wiring to each servo is separate, running down the left side of the aircraft, and is energized by separate switches actuated by the limiter handle in the cockpit. This arrangement of components is selected to give maximum safety in case of single electrical or hydraulic failure. With no stops on one side, due to single hydraulic failure, surface stops on the other rudder leaves the airframe in a safe condition.

e. Actuating cylinders:

(1) Each rudder stub fin contains four hydraulic cylinders all alike. Diagonally opposite cylinders are on one hydraulic system. The installation on each rudder is identical. One hydraulic system on each rudder is capable of producing full required hinge movement. The two systems, together, give twice the required amount. This necessitates the previously discussed surface limiter stops. These cylinders act on a torque member with connecting arm (gudgeon arm). A link between this arm and the surface causes the surface to move.

(2) The inboard elevon surfaces are driven by six cylinders arranged in three banks of two each. One cylinder of each bank is on system "A" and the other on system "B". The outboard elevon surfaces are driven by fourteen cylinders at each surface. Alternate cylinders take their hydraulic flow from hydraulic system "A" and "B".

f. Filtration: To protect the servo valving from foreign particles of harmful size, all servos have ten micron filters on the pressure supply on each hydraulic system. On the elevons, ten micron filters are used between the cylinders and the valving to protect against any particles that may be built into the hydraulic lines or enter the system while servicing cylinders. All servo and cylinder filters have a nominal filtering of ten microns with an absolute filtering ability of twenty-five microns. Some fibers may pass through the filters if their smallest dimension is less than twenty-five microns. The rudder package, having fewer cylinders and a one piece brazed manifold, which is ultrasonically cleaned, has no filters between the cylinders and servo valving.

**OXGART SECRET**

g. General schematic diagrams of the servos are shown on Figures 3, 4 and 5.

2. Investigation.

a. History of components prior to accident.

(1) All servo components used on airplane 133 were newly manufactured with the exception of the R.H. rudder servo valve. This valve assembly had previous service in another aircraft. It was removed from the aircraft and returned to the vendor for updating to the latest change. Complete functional tests were run and the valve assembly was equivalent to a new valve assembly.

(2) The yaw system A, right hand side, (Ar) transfer valve was removed because of a malfunction on a previous flight. It was replaced with a new transfer valve. Response and preflight tests were conducted with satisfactory results.

(3) The pitch trim actuator, located in the mixer mechanism, was rejected and a replacement actuator installed prior to the first flight.

b. Components installed on flight number 10.

(1) All servo components on flight number 10 were the same as used on previous flights with the exception of the yaw Ar transfer valve. (See 2a(2)).

c. Operation during flight number 10.

(1) From the records and reports of flight number 10, it has been determined that all servo components, with two exceptions, were operating in a normal manner prior to the aircraft's right hand turn into the final approach path. The two exceptions are; (1) "SAS yaw A light came on, coincidental with popping the shock on left engine. Attempted to recycle yaw but couldn't. Yaw A light remained on for remainder of flight". A failure of one of the SAS systems is not considered detrimental because a single SAS system has full capabilities of aircraft control. See SAS description. (2) "The left rudder trim indicator would not coincide with the right rudder trim indicator". Investigation revealed that the cockpit trim indicator was malfunctioning. Both yaw trim actuators were found to be within  $1/2^\circ$  of surface position with each other. This is normal rigging tolerance.

d. Condition and analysis.

(1) General structural damage in servo areas.

(a) The inboard servo areas were in good condition, except for some minor dents and scratches. See photos 4600 and 4647. The inboard elevons had some major damage but mostly at the trailing edge.

**OXGART SECRET**

**SECRET SECRET**

(b) The right hand outboard servo area was in fair condition with no major damage to the main structure surrounding the servo valve assembly. The structure in the actuating cylinder area was in fair condition from the inboard cylinder to cylinder #12. The outboard wing rear beam was broken between cylinders #12 and 13, from forces acting in several directions. The outboard elevon front beam was broken between the cylinder rod attachment points of cylinders #11 and 12. See photo 4678. The damage was created upon impact with the ground.

(c) The right hand outboard servo area was in fair condition inboard and aft of the servo valve assembly with the remaining structure gone. See photo 4633. The area surrounding the actuating cylinders was in good condition outboard to cylinder #6. Between cylinders #6 and 7 the outboard wing rear beam was broken but still intact with the inner structure. The rear beam was broken completely off between cylinders #11 and 12. The outboard elevon front beam was broken between the cylinder attachment points of cylinders #9 and 10. The elevon was deformed mostly aft and down. Because of the position of the aircraft upon initial impact, the right hand outboard wing and elevon suffered the severest damage.

(d) The left hand rudder servo area was in poor condition. The sheet metal structure surrounding the servo valve assembly was crumpled and bent. The main trusses supporting the actuating cylinders and gudgeon (actuating) arm were in fair condition with portions of forward and aft structure still attached. See photo 4661. All structural damage to the left hand stub fin was caused by the impact of the crash.

(e) The right hand rudder servo area structure was gone. The trusses supporting the actuating cylinders and gudgeon arm were in poor condition but were still attached to portions of the forward and aft structure. The right rudder had severe damage because of the position of the aircraft upon initial impact. See photo 4625.

(f) The structure surrounding the mixer (tail cone) was severely damaged. The structure was partially torn away from the main fuselage structure. This damage was caused by impact as the aircraft was sliding on the ground and breaking up. See photo 4651.

(2) Damage to servo valves and actuating cylinders.

(a) The right and left inboard elevon servo valve assemblies and actuating cylinders were in very good condition with the mounting attachments, input mechanism, electrical connections and plumbing lines all in place and safetied. See photos 4600 and 4647. The inboard servos were removed from the wreckage and taken to the Lockheed Functional Test Facility. (See Flight Control Tests and Analysis). An actuating cylinder from each inboard elevon was examined to determine if an elevon surface position could be established prior to impact. Because of the good condition of the surrounding structure, the actuators were in a good condition and no surface corresponding position could be determined.

(b) The left hand outboard elevon servo valve assembly and actuating cylinders were in very good condition with the exception of the five outermost actuating cylinders. Cylinders #10 and 11 were in

**SECRET SECRET**

**OX CART SECRET**

a different stroke position than the cylinders farther inboard due to the elevon being deformed. Cylinders #12, 13 and 14 were damaged. All attachments, both mounting and plumbing, were found to be in place and safetied. Cylinder #12 from the left hand outboard elevon was examined to determine a surface position at time of impact. The results were negative.

(c) The right hand outboard elevon servo valve assembly had the lower mounting bolt pulled loose from the barrel nut. The input mechanism was in fair condition with the exception of the "down spring" cartridge. The rod end of the cartridge was pulled from the bearing but the bearing was attached to the structure. The outermost input filter cap had the safety wire broken and was finger tight. All plumbing attachments were in place and safetied. Some scratches were observed on the servo valve body. See photo 4633. Before the servo valve assembly was removed from the wreckage, its condition was examined carefully. Two factors were noted: (1) There was deformation on one of the attaching lugs as a result of the impact. See photo 4633. (2) The valve input crank arm required between 41 and 46 pounds to move it in a direction to produce up elevon and approximately 2 to 5 pounds to move it in a direction to produce down elevon. See photos 4598 and 4601. The bias spring inside the valve was not capable of returning the valve input crank to its down position. The present functional test requires that the valve input crank be self-returning with not over 30 pounds required to move it in the up direction. A normal valve operates with even lower loads and is also self-returning. The servo was removed from the wreckage and taken to the manufacturer for inspection. (See Flight Control Tests and Analysis). Actuating cylinders #1 thru 8 were in place with the mounting attachments and plumbing safetied. Cylinders #7 and outboard had the plumbing broken off. Cylinder #9 was in place and safetied but had the bracket retaining nut and jam nut loose on the connecting link. Cylinder #9 had the end of piston rod cracked but from the brinelling of the threads on the jam nut, it was determined that the crack was caused after impact. Cylinders #10 and 11 had the connecting link pulled from the beam with portions of structure attached. The clevis bolts and nuts were in place and safetied. Cylinders #12, 13 and 14 were attached to a portion of the outboard wing rear beam. The clevis bolts and nuts were in place and attached to portions of the outboard elevon front beam structure. The piston rods showed evidence of connecting link overtravel but in approximately an outboard direction. See photo 4848 and 4849. Cylinders #12, 13 and 14 were disassembled and inspected. All three cylinders showed approximately the same damage conditions. The piston rod was flared and/or split on one side from overtravel of the connecting link. The bronze scraper rings, through which the piston moves, were deformed on an arc approximately 45 degrees outwards from the piston rods on each of the actuators. On all three cylinders the ring deformation corresponded with the deformation of the piston rod by the connecting link. This was very definite since there was transference of bronze particles onto the piston rod, there was "finger in glove" corresponding indentations of the crack in the piston rod into the bronze ring, and the deformation of the bronze rings fitted the mating deformations of piston rods at their ends. The aircraft impacted the ground in an inverted roll attitude to the left on the right wing and right

**OX CART SECRET**

**OXCAR SECRET**

rudder at an approximate speed of 340 feet per second. At the moment of impact, the righthand outboard elevon was deformed mostly rearward. The hydraulic lines broke a fraction of a second afterwards. The deformations on the cylinder rods occurred instantaneously on ground impact, and must be accepted as occurring at the moment of impact. From the bronze scraper ring markings and appearance, it is evident that all three cylinders were in the fully retracted position. This position corresponds to the right hand outboard elevon being fully down.

(d) The left hand rudder servo valve assembly was in fair condition. The main shear pin attachment was in place but the forward gate link was broken. The link mounting bolts were in place and safetied. The solenoid valve was in place with the forward limit piston extended and the aft limit piston retracted. Because of the variations in friction exerted on the bar "x" piston rod seals, the limit pistons may or may not retract when the solenoid is energized. Because one limit stop piston is retracted, it has been concluded that the solenoid valve was operating properly at time of impact. The transfer valves were in good condition. The LVDTs had their electrical receptacles missing. The actuating cylinders were in place with all mounting bolts safetied. The plumbing manifold had all attaching bolts in place. The input rod was broken but still attached to the input summing lever and forward lug of the trim actuator. The aft end of the trim actuator was attached to its supporting structure. The trim actuator shear pin was severed. The aft end of the gudgeon arm was damaged but the pivot pin for the rudder link was in place. The rudder link was not damaged and was attached to the rudder. The trim actuator had no apparent physical damage and could not be operated electrically. The feel spring operated normally, although no feel forces were measured. See photo 4661. The damage to the left hand rudder servo assembly was caused by impact with the ground.

(e) The right hand rudder servo valve assembly was badly damaged. The servo valve was separated at the attaching joint between the two main bodies. The attaching bolt stubs were in the forward body. The main shear pin attachment bolt stubs were in the aft body. The forward mounting link was attached to the structure but not to the servo. Both mounting link attachment bolts were in their proper location with the servo attachment retaining link bearing. The solenoid valve was in place with both limit pistons retracted. Both transfer valves were damaged. The upper transfer valve had the electrical receptacle broken off with the lower transfer valve completely. The actuating cylinders were in place with all mounting attachments safetied. The plumbing manifold was mangled, but all attaching bolts were in place and safetied. The input rod was broken but still attached to the input summing lever and the trim actuator forward lug which was broken from the trim actuator. The aft lug of the trim actuator was broken off but attached to the trim actuator support. The trim actuator shear pin was severed. The aft end of the gudgeon arm was damaged, but the pivot pin and rudder connecting link were in place. The trim actuator had major damage and no attempts were made to operate it electrically. The feel spring operated normally although no feel forces were measured. See photo 4625. The damage to the right hand rudder servo assembly was caused by impact with the ground.

**OXCAR SECRET**

**OXGART SECRET**

(f) The mixer was in fair condition. Its support attachments were in place, although the aft support rod was badly damaged. The connecting "dog-bone" link between the roll input torque tube and the intermediate bell crank was broken at one end. Analysis of the fracture revealed that the break in the link was caused by side bending perpendicular to the main axis of the shaft. See photo 4865. Since this is contrary to the normal push pull load condition, it had to have failed as a result of impact. Both pitch and roll feel spring assemblies would not operate properly. However, after cleaning their operation was normal. No feel forces were measured.

(g) The roll trim actuator had its rod end jammed into the screw-jack tube. After pulling the rod end to its proper position before impact, the length was noted. See photo 4685. The length of the roll trim actuator indicated that the elevon control surfaces were trimmed to approximately zero surface angle. The trim actuator was operated electrically and extreme travel positions and rate were normal.

(h) The pitch trim actuator was mounted properly. The indicator transmitter was in place and the auto trim transmitter was completely gone. See photo 4651. Attempts were made to operate the trim actuator electrically but neither motor would turn. The length of the pitch trim actuator was measured indicating that the elevons were trimmed to a  $2.4^{\circ}$  up pitch position.

(i) All linkage mechanism attaching bolts were in place and safetied. Because of the structural damage to the tail cone and the nature of the individual breaks, it was determined that the damage to the mixer mechanism was caused by post-crash impact.

#### E. FLIGHT CONTROL TESTS AND ANALYSIS

1. Control components in ship serial 131 were disconnected or blocked as follows in order to demonstrate failures in the control system that might have caused loss of control of aircraft serial 133 as described by Mr. Park.

a. Test #1 - To simulate stuck input to LH inboard elevon servo. Input arm AC 851-5, on LH inboard elevon servo, AC 700, was wired to structure to prevent movement of pushrod from mixer. Hydraulic pressure was applied from gig and the control system operated from the cockpit by stick movement and electrical trim with the following results:

(1) The stick could be moved only in a direction to the right and aft or forward and to the left at an angle of approximately  $45^{\circ}$  to the center line of ship.

(2) Movement of the stick to the right and aft produced right surface up only while the left surfaces remained fixed.

**OXGART SECRET**

**EXCERPT SECRET**

(3) Electrical nose up trim produced R.H. surface up travel with no movement of left surfaces.

(4) Electrical nose down trim produced R.H. surface downtravel with no movement of the left surfaces.

Conclusion - The loss of control was not caused by this situation as at the time of the incident the pilot could move the control stick in a normal manner. With this situation, abnormal stick forces would have developed. This was not reported.

b. Test # 2 - To simulate stuck input to R.H. inboard elevon servo. Input arm AC852-5, on R.H. inboard elevon, was wired to structure to prevent movement of pushrod from mixer. Hydraulic pressure was applied from gig and the control system operated from the cockpit by stick movement and electrical trim with the following results:

(1) The stick could only be moved in a direction to right and forward or to the left and aft.

(2) Movement of the stick to the right and forward produced left surface down with no movement of the right surfaces.

(3) Nose down trim moved the stick to the right and the left surfaces down.

(4) Nose up trim moved the stick to the left and the left surfaces up.

Conclusion - The loss of control was not caused by this situation as at the time of the incident the pilot could move the control stick in a normal manner. With this situation, abnormal stick forces would have developed. This was not reported.

c. Test #3 - To simulate broken roll trim actuator or loss of attaching bolt in the mixer roll linkage. AC 1125-13 bolt was removed which connects the roll trim actuator to the AC 1004-1 lever assembly, with the following results:

(1) With hydraulic pressure applied, the surfaces could be made to move in a roll direction by applying a force on AC 1004-1 lever from which the trim actuator had been disconnected. Roll movement of surfaces could be obtained in either direction and at different rates depending on which direction and how hard the force has been applied. After being started the surfaces continued to move in roll at a constant rate after the initiating force had been removed until a force in the opposite direction was applied.

(2) The stick was moved in a roll direction from the cockpit. The feel was normal because the feel spring was being operated but no surface response was obtained because of being disconnected from the mixer output.

**EXCERPT SECRET**



**DUPLICATE SECRET**

(3) The stick was moved in a pitch up direction. The first try, the L.H. surface moved up and the R.H. surface down. The second try, right and left surfaces both moved up with the L.H. faster than the R.H. The third try, the left surface was then moved in a pitch down direction. The first try, the left surface moved down and the left surfaces moved up. The second try, the left surface started down, then the L.H. surfaces changed direction and started up with the R.H. surfaces continuing down. It is noted that no set pattern exists under this condition and that the stick provides the force required to start motion in both right and left directions in a random manner.

Conclusion - The loss of control of the ship by Mr. Park could have been caused by this situation. The actuator was examined and found to be damaged. The rod attaching the rod end to the actuator were sheared. The rod was inserted into the actuator. The actuator was connected electrically and found to be operable. It was determined that the damaged actuator was operable and that the actuator was operable at time of the incident. Thus the loss of control was not caused by this situation.

d. Test #4 - To simulate failure in mixer of YS 170 pushrod or loss of attaching bolt. It was removed from forward end of YS 170 pushrod (pitch), with the following results:

(1) When hydraulic pressure was applied both R.H. and L.H. surfaces moved up approximately  $25^{\circ}$  due to the servo valve bias.

(2) The control stick was moved to the full left roll position. The left surface moved up to approximately  $35^{\circ}$  up and the R.H. surface moved down to approximately  $3^{\circ}$  up position.

(3) The control stick was moved to the full right roll position. The left surface moved down to approximately  $8^{\circ}$  up position. The right surface moved up to approximately  $35^{\circ}$  up position.

Conclusion - The loss of control of the ship caused by this situation as at the time of the incident the pilot would have experienced a severe pitch up attitude and there is no evidence to indicate that the ship was in this position.

e. Test #5 - To simulate L.H. outboard servo stuck in up position. The inboard end of the 938 summing lever on L.H. outboard servo was wired to structure to prevent motion. The surface was in the up position.

(1) The stick in the cockpit was operated through full travel in pitch and roll. The electrical trim was operated in pitch and roll. All stick forces and surface responses for the three remaining surfaces were normal. The L.H. outboard surface remained fixed in the up position.

**DUPLICATE SECRET**

## OXCART SECRET

Conclusion - The loss of control was not caused by this situation as at the time of the incident the pilot's corrective action would have resulted in a pitch up condition. There was no evidence to indicate that the elevon was in this position.

f. Test #6 - To simulate R.H. outboard servo stuck in the down position. The inboard end of AC 938 summing lever was blocked to structure to prevent motion. The surface was in the down position.

(1) The stick in the cockpit was operated through full travel in pitch and roll. The electrical trim was operated in pitch and roll. All stick forces and surface responses for the three remaining surfaces were normal. The R.H. outboard surface remained fixed in the down position.

Conclusion - The loss of control was due to this situation. This stuck surface position, coupled with the pilots corrective action, would cause the aircraft to pitch down as well as left roll. Other findings in this report indicate that this malfunction of the control system occurred.

g. Test #7 - To simulate loss of AC 1109 R.H. outboard follow-up rod or rod attachments. The followup rod was disconnected and hydraulic pressure applied.

(1) Outboard surface went to 20° down position.

(2) All other surfaces operated normally.

Conclusion - The loss of control could have been caused by this situation. But since the outboard followup rod was found to be intact and connected; this situation did not occur in flight.

h. Test #8 - To simulate loss of AC 1109-6 L.H. inboard follow-up rod, the followup rod was disconnected and hydraulic pressure applied.

(1) The L.H. inboard and outboard surfaces moved to approximately 35° up position.

(2) R.H. surfaces responded to stick movement and trim while the L.H. surfaces remained in the up position.

Conclusion - The loss of control could have been caused by this situation. But since the inboard followup rod was found to be intact and connected; this situation did not occur in flight.

2. The inboard elevon servo valve assemblies were taken to the Lockheed Functional Test Facility.

a. They were cleaned up externally and were intentionally left untouched internally. These units were then installed in the flight

## OXCART SECRET

**SECRET**

simulator and operated with temperature shock exposure. Both units exhibited momentary "stuck spool" conditions as shown by the pilots' control stick moving erratically around the cockpit in spite of pilot restraint. (See figure 6.) As soon as temperatures became more equalized, this condition disappeared. Further attempts to repeat the same valve stickiness failed. It will later be explained that during the investigation of the right hand outboard servo, simply cleaning the valve assembly, reduced the force necessary to move the input valve crank from approximately 45 lbs. to 31 lbs. Note that the effect of contamination could be accumulative with the temperature shock effect in that contamination could effectively reduce metering spool clearances.

3. The right hand outboard elevon servo valve assembly was taken to the manufacturer for inspection, disassembly and testing.

a. This inspection and disassembly was carried out with great care with the following results: The impact damage which deformed the lug on the valve had no effect on its internal operation or upon the sticking condition of the valve input crank arm. By progressive disassembly it was established that the cause of stickiness was in the valve body in which operates the servo spool. In the bore of the valve body there existed a high spot, sufficient to produce burnishing on the high spot and a drag force on the servo spool. It is apparent that this high spot is due to valve assembly warpage. This in turn has caused the valve wafers which are shrunk in place to lift slightly - perhaps as little as 0.00005 inches. This would also explain the ratchet motion of this valve - less force to move in one direction vs the other. The measurements on the stickiness of the valve input crank arm checked almost exactly with the measurements made before removal of the servo valve from the crash, (see above); and approximately 80 percent of this force was found to be a result of the sticking valve spool. For practical, hydraulic oil samples were taken from various points with the valve for the purpose of contamination count. A preliminary examination showed appreciable contamination in many parts, resulting from water, dirt and foam entering through broken lines during fire fighting operations. However, samples of oil taken from within the crank arm case were, it is believed, fairly realistic. See report on contamination. The total servo valve was then completely disassembled, cleaned, and re-assembled without any physical change to any of the parts. It was then rechecked in this cleaned condition for input crank forces required. The force required to move the input crank arm in the up elevon direction was now approximately 31 pounds, a drop of the 41 to 46 pounds measured in the original condition. The servo valve was capable of returning the valve input crank arm to the neutral position. However, the valve still exhibited the same general operating characteristics as it originally exhibited. The servo valve was set up in the Functional Test Lab and subjected to a "hot shock" test, consisting of elevating the hydraulic oil supply temperature and operating the valve so as to introduce the hot oil into the valve porting. The results of these hot shock test are as follows:

**OXFORD SECRET**

<u>Body Temp.</u> <u>degrees F</u>	<u>Oil Temp.</u> <u>degrees F</u>	<u>Anti-bias</u> <u>direction lbs</u>	<u>Bias direction</u> <u>lbs</u>
200	550		
300	550		
400	550	190	
440	550	132	22
460	550	52	10
470	550	32	6
480	550	27	4
500	550	22	1
		19	1/2

Note that the input crank force did exceed 190 lbs when shocked with 550° F oil. The force at the input crank arm for the standard follow-up system in the test was limited to 170 (cold) to 136 (hot) from the spring cartridge. An attempt was made to cold shock the valve where the exterior body of the servo reached 385° F, and the valve was operated with oil at 550° F. At no time did it take more than 40 lbs to move the valve. In addition, as far as this particular test is concerned, the effect due to cold shock, although it is apparent that some friction did exist, as the temperature stabilized load was of the order of 27 to 30 lbs.

4. Next, the valve and the spool was measured to determine its clearance with respect to the spool. It basically had 0.0003 inches clearance, except for the high spot, which reduces the clearance locally to essentially zero. The valve body was then honed 0.0001 inches to a diametrical clearance of 0.0004 inches with no high spots existing in the valve. In this configuration the valve was reassembled and resubjected to hot shock with 500° F oil and a temperature at 125° F. The results of these hot shock tests are as follows:

<u>Body Temp.</u> <u>degrees F</u>	<u>Oil Temp.</u> <u>degrees F</u>	<u>Anti-bias</u> <u>direction lbs</u>	<u>Bias direction</u> <u>lbs</u>
125	500		
150	500	70	6
210	500	65	10
270	500	60	0
310	500	50	0
360	500	50	0
410	500	50	0
430	500	50	0
450	500	50	0
		38	0

Note that the input crank load never rose above 70 lbs throughout the exposure. Thus there was great improvement over the hot shock effect in the condition as it existed in the previous hot shock test. The leakage with this 0.0004 clearance was approximately 20% above present values for cold intersystem leakage.

**OXFORD SECRET**

**SECRET**

5. As a further test, the metering valve body was mechanically loaded in an attempt to lift the metering spool up to a point that galling was evident. A maximum load of 20,600 lbs, centrally located, was applied to body. At this applied load, it took a force of 770 lbs to move the metering spool but no galling was evident. This indicates that much higher binding loads can be absorbed in the valve assembly without actually galling the tool and parts. Thus, if high control system loads are available, the valve spool can be forced to move without damage.

6. In order to establish correct data for flight simulation prior to the accident, flight test data has been used. The following table shows such flight test instrumentation data obtained from aircraft 121. Although this table shows the temperature for the inboard servo assembly, the outboard servo assembly exhibits the same temperature characteristics.

<u>Flt #</u>	<u>L. Rudder Servo Transfer Valve</u>	<u>R. Rudder Servo Inbd Package</u>	<u>System A Heat Exch Disch L.</u>	<u>Remarks</u>
	<u>°F Max</u>	<u>°F Max</u>	<u>°F Max</u>	
92	342	317	278	2 min above M 3.0 Max M 3.14
99	390	363	318	5½ min above M 3.0 Max M 3.16
102	466	425	365	10 min @ M 3.15
112	Not Recorded	414	376	11 min above M 3.0 Max M 3.12
119	est 478	435	385	30 min @ M 3.10
	est 500	460	410	120 min @ M 3.20 (est)
122	est 478	435	375	10 min @ 3.05

Figure 7 shows the relationship of temperatures, of various items and time with respect to altitude and mach number for the profile of the flight of airplane 133 prior to the accident. This data was used in simulating the flight conditions during the tests described previously.

7. It is very difficult to take truly representative oil samples in a crash where so much disintegration has taken place. However, samples were obtained from the crankcase of both the R.H. and the L.H. outboard servo valves. These samples should have been fairly well protected from crash contamination. The sample taken from the R.H. outboard servo crankcase showed that the oil contained particles of lubribond, and metal, none of which could have entered through the pressure input filters. The count of metallic fines was very high.

**SECRET**

**SECRET**

The sample taken from the outboard servo crankcase was the same as that taken from the inboard servo. There is no conclusive explanation as to how these particles entered the servo valves. The large particles must have been the result of manufacturing operations and the metallic fines are normally generated during operation. The samples of oil were analyzed by infrared methods. It was determined that the oil had not deteriorated because of temperature nor had the amount of additives changed from that of new oil.

8. The chase pilot reported that the airplane control surfaces were faired at the time of pilot ejection. Tests were conducted to determine if the two chase plane pilots, Col. Holbury and Capt. Roussell, could identify aircraft surface positions under similar conditions. Airplane 131 was placed on the compass rose at a heading of 320 degrees. The time of day and weather conditions were identical to the incident conditions at the time of pilot ejection. Col. Holbury and Capt. Roussell made passes overhead in a helicopter at airplane 131 at the approximate elevation and azimuth angles coincident with those at the time of the incident. The airplane surfaces were moved to various pitch and roll positions while the pilots recorded their observations. The results of the tests were recorded and found to be inconclusive. The pilot's comments were that it was difficult to determine the degree of surface position during the tests. Only full up or full down surface position could be readily identified. They further commented that at the time of the incident they were observing the cockpit section of the airplane.

9. The following is an analysis of events leading up to the crash of aircraft 133 on the assumption that the right outboard elevon has failed. Taking the evidence available after the crash, the pilots statement and various witness reports the following sequence of events can be established. The pilot made a right turn on to final approach for landing after a relatively rapid spiral descent from a flight condition of Mach 2.8 and 78,000 feet. During the descent at approximately .9 Mach and 300 KEAS the gear was extended for the purpose of increasing rate of descent. 4,000 pounds of fuel was transferred to tank No. 1. While in the landing pattern the speed was bled off to the 200 KEAS existing in the final approach leg in excess of one mile from the end of the runway. Rate of descent during final was reported to be higher than usual. Low throttle settings were reported used during final approach. A slight roll off to the right was corrected by the pilot with a left roll input. The aircraft then started to roll left. The pilot started applying a slow aileron input to correct the left roll. At least in the initial statement the pilot felt that he had checked or slowed the roll at first. At no time did the pilot note excursions from 1 g flight. Due to the roll condition the pilot considered a go-around and started applying throttle. Almost simultaneously with throttle movement he hit the aileron stick travel limit. With no control in roll he ejected at approximately 200 feet altitude from the steeply banked aircraft. The aircraft continued to roll and is estimated to have impacted at an attitude of approximately 216 degrees of left bank with the right wing tip making first contact. Facts, investigation and evidence obtained from the wreckage indicates the following conditions existed on impact. The airspeed was 214 KEAS. The outboard right elevon was positioned at approximately 20 degrees trailing edge down. The aircraft controls were trimmed to approximately

**SECRET**

**OXGART SECRET**

zero in roll and yaw and 2.4 degrees trailing edge up on the inboard elevons in pitch. A review of the scene indicated that the nose of the aircraft hit slightly after the wing tip implying that the aircraft was at a slight nose up attitude. Reviewing the events and evidence presented above with the assumption that the right outboard elevon valve had jammed in an open condition, the following conclusions can be drawn. The action of the pilot to correct for a right roll-off or possibly a small pitch or roll damper input would be sufficient to crack the valve to an open position whereupon it could jam resulting in driving the right outboard elevon to the hardover position in which it was found. Referring to Figure 8 the elevon positions for trimmed flight with the right outboard elevon driving to the hardover trailing edge down position is presented. This data is presented with respect to the trimmed position obtained from the pitch trim actuator on impact. It is apparent from pilot comment that the valve did not jam full open since in that event, with the surface moving at 30 degrees per second the pilot would have lost roll control in .29 seconds and had a hardover condition in .85 seconds. This is contrary to his statement that he applied corrective action slowly. In addition the pitch transient would have been quite severe. The lack of comment on a severe pitch transient and the slow input of corrective aileron establishes the fact that the surface was drifting hardover slow enough to be well within the pilot's capability to apply corrective action within the limits of his control authority. Figure 8 shows that to maintain 1 "g" flight requires little more than a small back pressure on the stick during the time that some stick aileron is applied. However, it also shows that when the right outboard elevon has reached a point of 3.3 degrees trailing edge down, a total movement of 8.7 degrees from the trim position, the mechanical stops on differential elevon available are reached and roll control is lost. Prior to this point the left roll could have been slowed or checked as initially indicated by the pilot. Figure 8 further shows that once roll control is lost the roll rate will build up to approximately 2 degrees per second once the hardover outboard elevon position is reached which seems to be consistent with pilot and witness reports. Once the pilot ejects the stick will return to the neutral position. Thus the aircraft is out of control in both roll and pitch. The roll rate would increase to approximately 41 degrees per second and a large nose down moment would be applied. The nose down moment referred to in inverted aircraft would explain why the aircraft impacted in an almost flat to slightly nose high attitude. The descent of the aircraft would explain the buildup in speed to 214 KEAS at impact.

## 10. Findings of servo assembly

- a. The described problems relate to the servo valves, actuating cylinders, and mixer mechanism as a result of aircraft impact.
- b. Checks of the condition of the servo valves reveal more contamination in the valves than in the cylinders of the hydraulic service carts. This contamination appears to be primarily metal chips built in by the valve manufacturer.

**OXGART SECRET**

**SECRET**

c. The positions of the outboard elevon cylinders on the right outboard elevon definitely established that this elevon was full down upon impact.

d. The unusually close fit of the metering spool of the right outboard elevon servo coupled with leakage, a temperature shock condition, and oil contamination caused the spool to bind in an open position. This binding could not be overcome by the elevon mechanical transmission system with its nominal force of 20 pounds.

e. The right outboard elevon servo in a stuck open condition most probably caused the accident.

F. RECOMMENDATIONS

1. It is recommended that:

a. The diametrical clearance be increased between the metering spool and the valve body of the servo units to minimize the possibility of binding and still retain acceptable hydraulic fluid leakage.

b. The servo valve assemblies be subjected to a temperature shock environment in order to stabilize all components in the main metering valve prior to a functional test.

c. All preliminary functional and temperature shock tests be conducted with the servo input filters in place but not the output filters so as to clean the valves of contaminants incurred during manufacture. (Note: The output filters will be installed prior to final high temperature functional test.)

d. The elevon mechanical transmission system from the inboard elevon to the summing lever of the outboard servo be strengthened in order to overcome and operate a binding spool should it occur.

G. ACTION TAKEN

1. All similar servo valve assemblies on aircraft, in supply, and in process of manufacturing are being reworked in accordance with the above recommendations.

**SECRET**



25X1A

**SECRET**

25X1A



Technical Consultant  
Directorate of Aerospace Safety  
25X1A



Controls Engineer  
Lockheed Aircraft Corporation



Servo Mechanism Engineer  
Lockheed Aircraft Corporation

**SECRET**

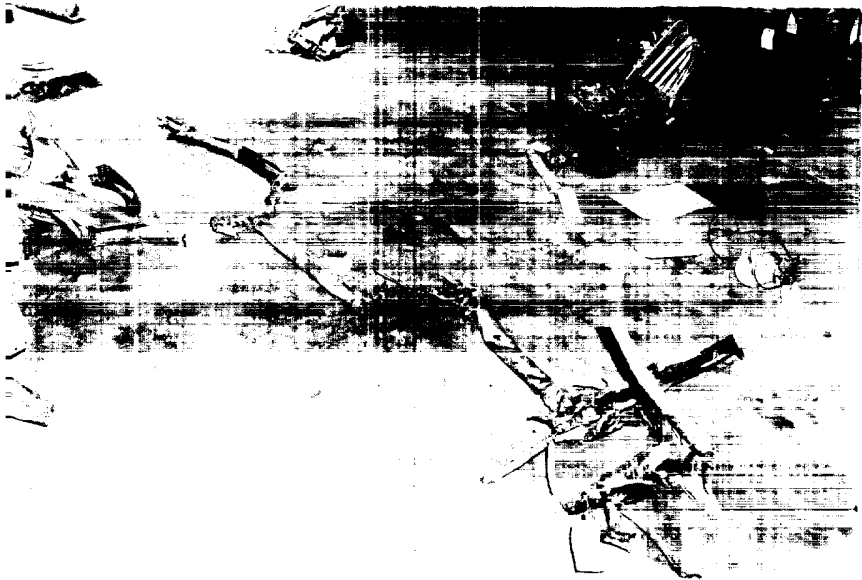
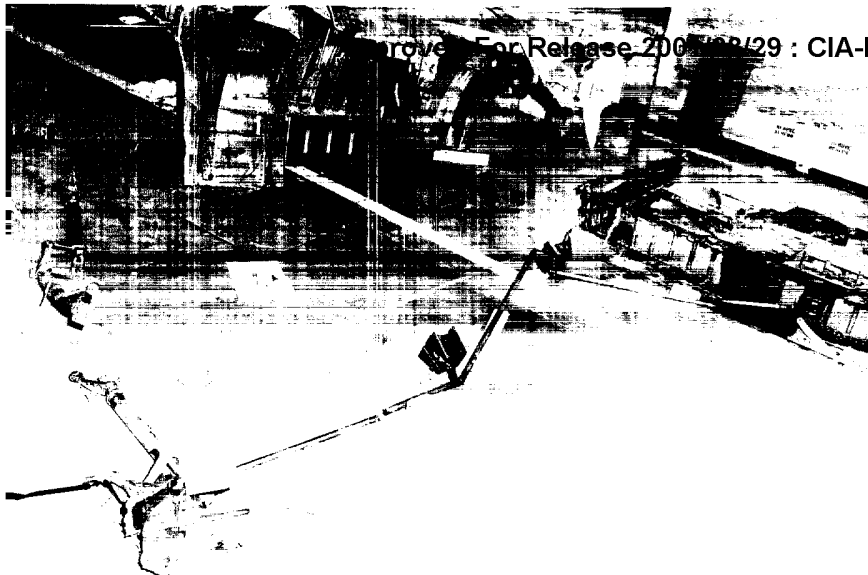

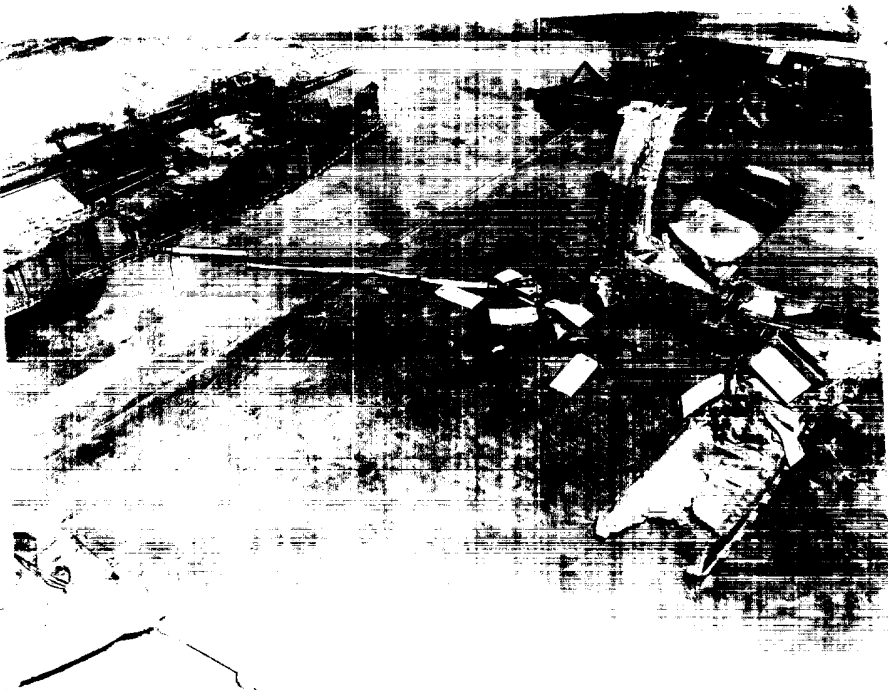
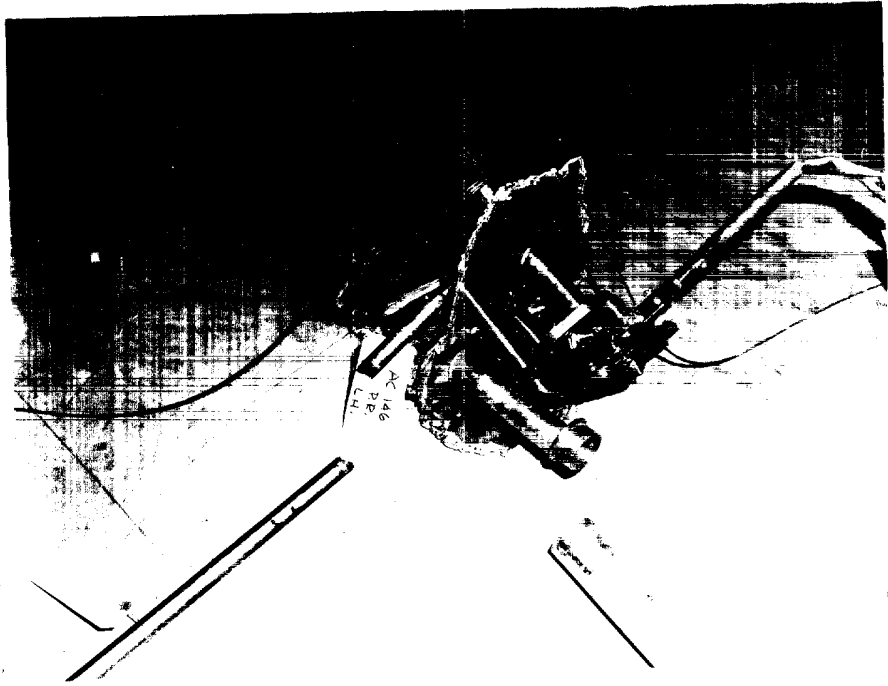

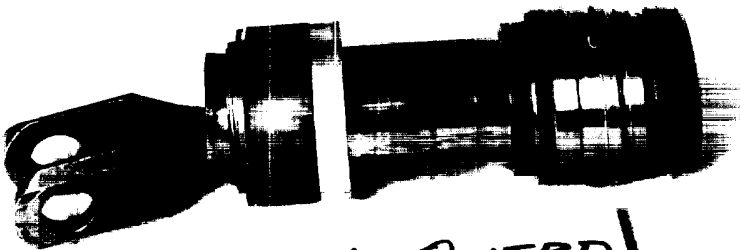

R. H. OUTBD  
CYLINDER  
#14

ENGINE  
INSTR.

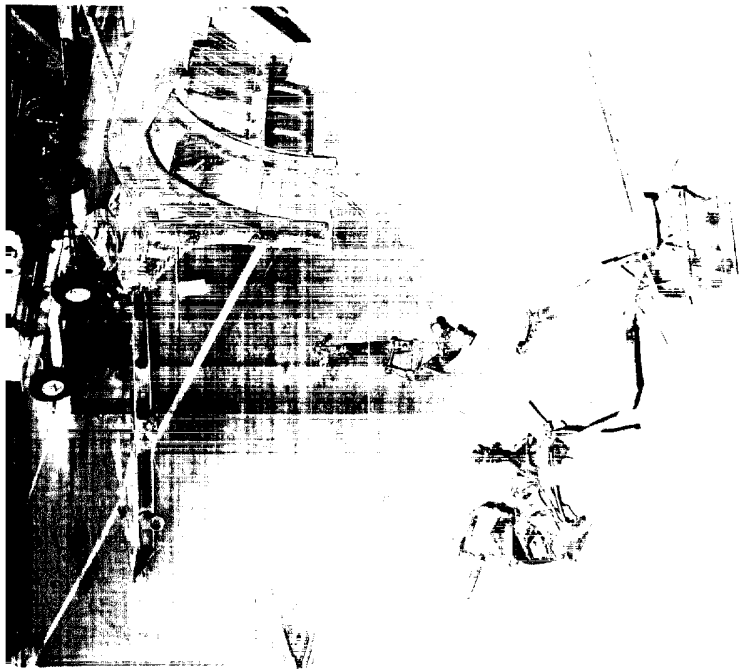
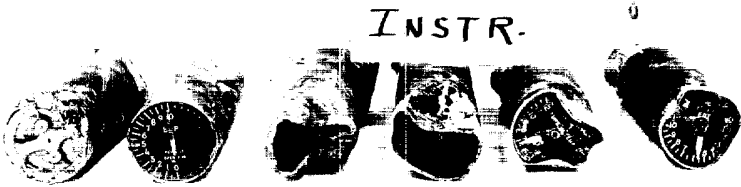

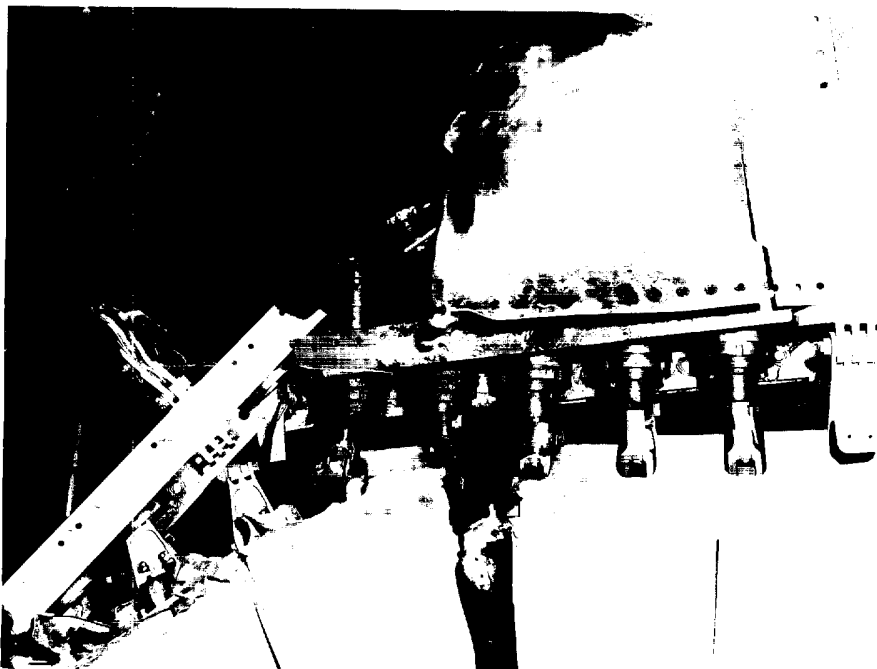
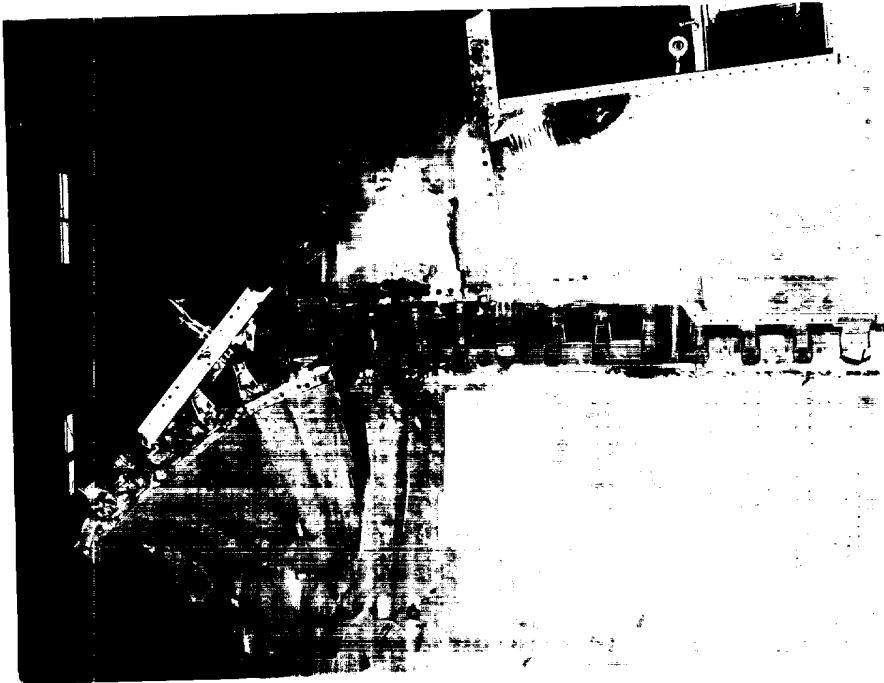

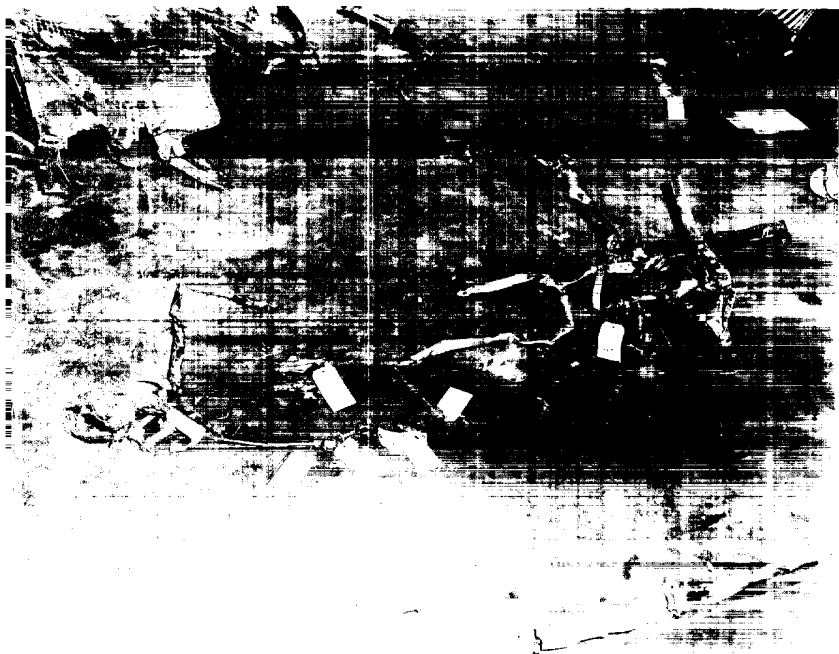

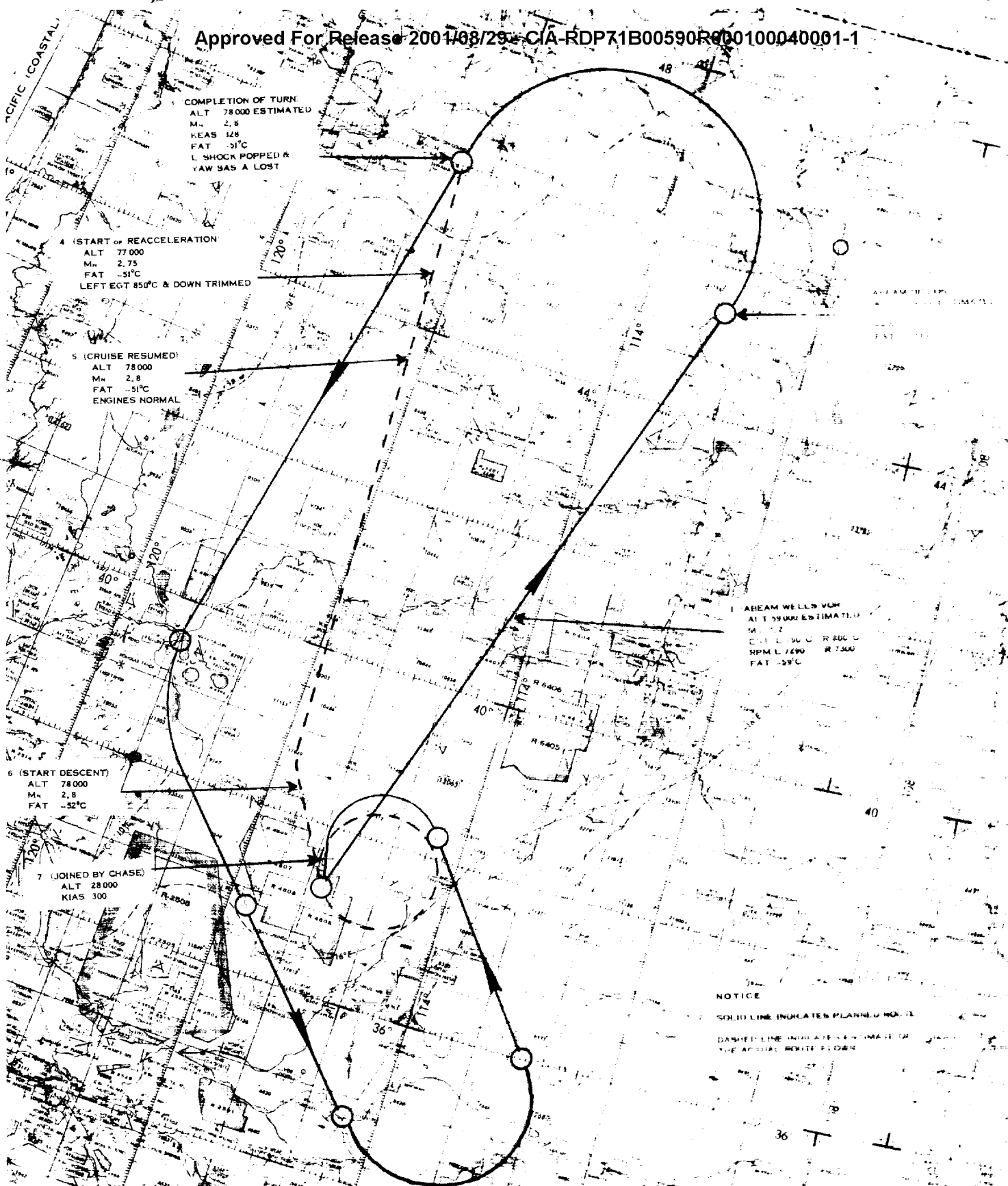

COMPLETION OF TURN  
 ALT 78000 ESTIMATED  
 M<sub>0</sub> 2.8  
 KEAS 128  
 FAT -51°C  
 L SHOCK POPPED &  
 YAW SAS A LOST

4 (START OF REACCELERATION)  
 ALT 77000  
 M<sub>0</sub> 2.75  
 FAT -51°C  
 LEFT EGT 850°C & DOWN TRIMMED

5 (CRUISE RESUMED)  
 ALT 78000  
 M<sub>0</sub> 2.8  
 FAT -51°C  
 ENGINES NORMAL

6 (START DESCENT)  
 ALT 78000  
 M<sub>0</sub> 2.8  
 FAT -52°C

7 (JOINED BY CHASE)  
 ALT 28000  
 KIAS 300

ABRAM WELLS VOR  
 ALT 59000 ESTIMATED  
 M<sub>0</sub> 2.2  
 RPM L 7290 R 7500  
 FAT -55°C

NOTICE

SOLID LINE INDICATES PLANNED ROUTE  
 DASHED LINE INDICATES ESTIMATE OF  
 THE ACTUAL ROUTE FLOWN

1487



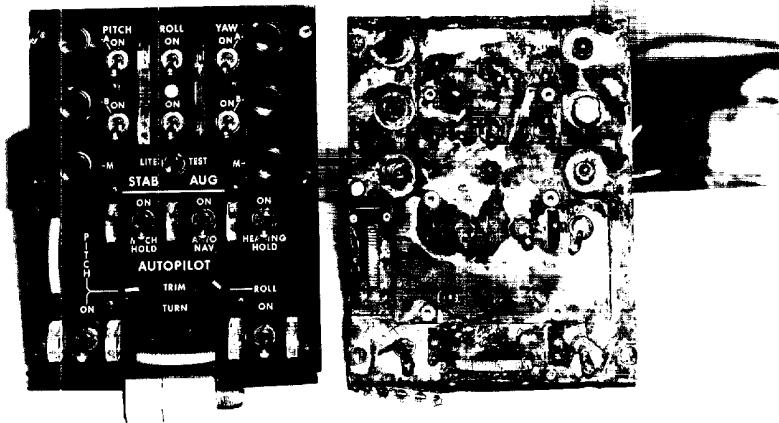
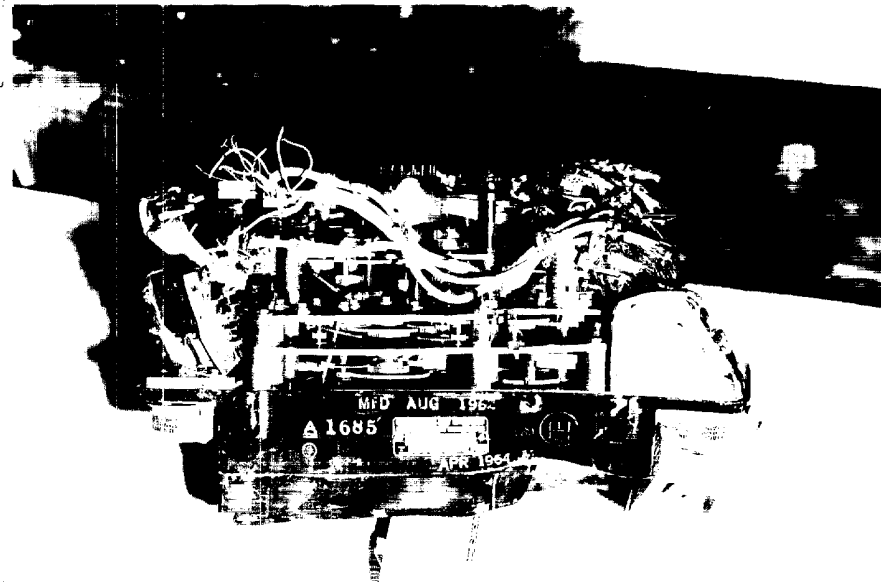

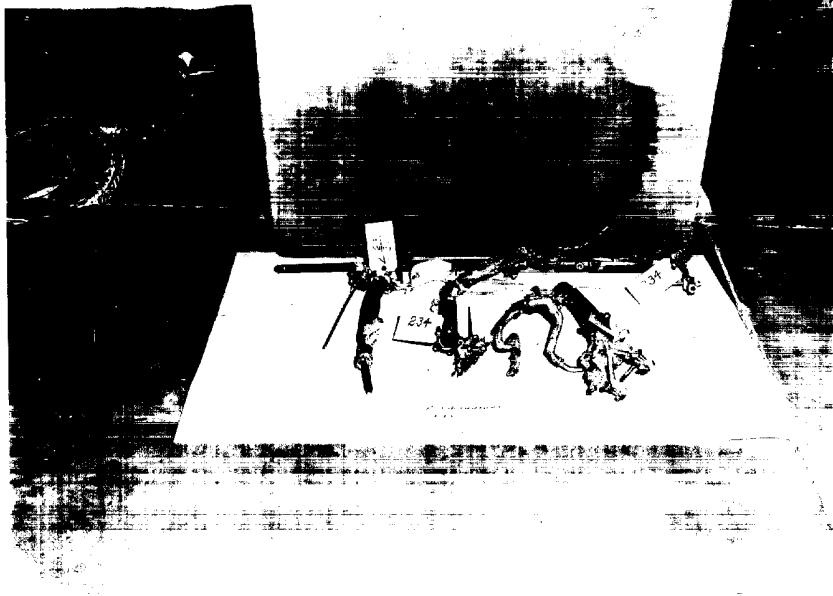

4795



4796

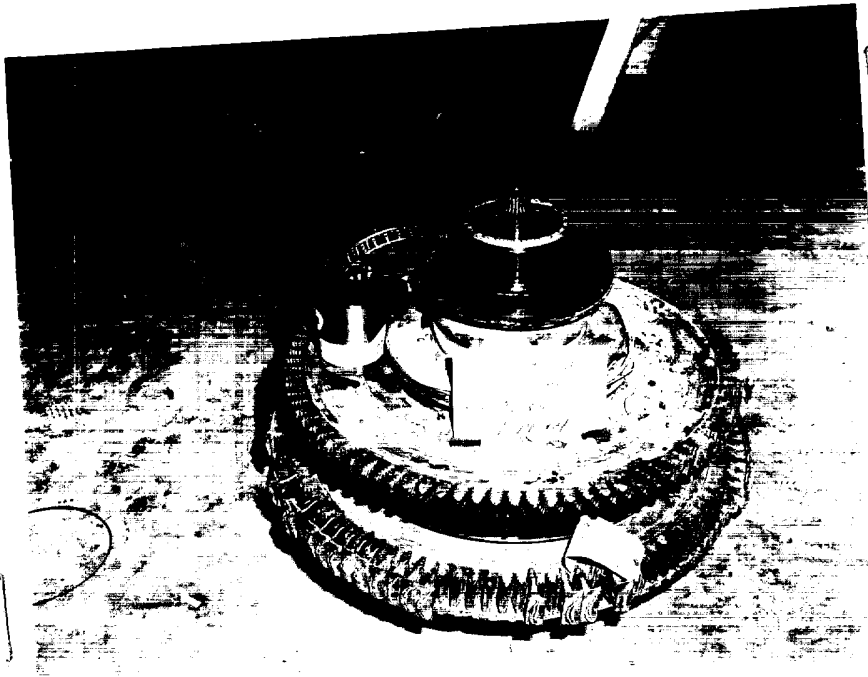

4780

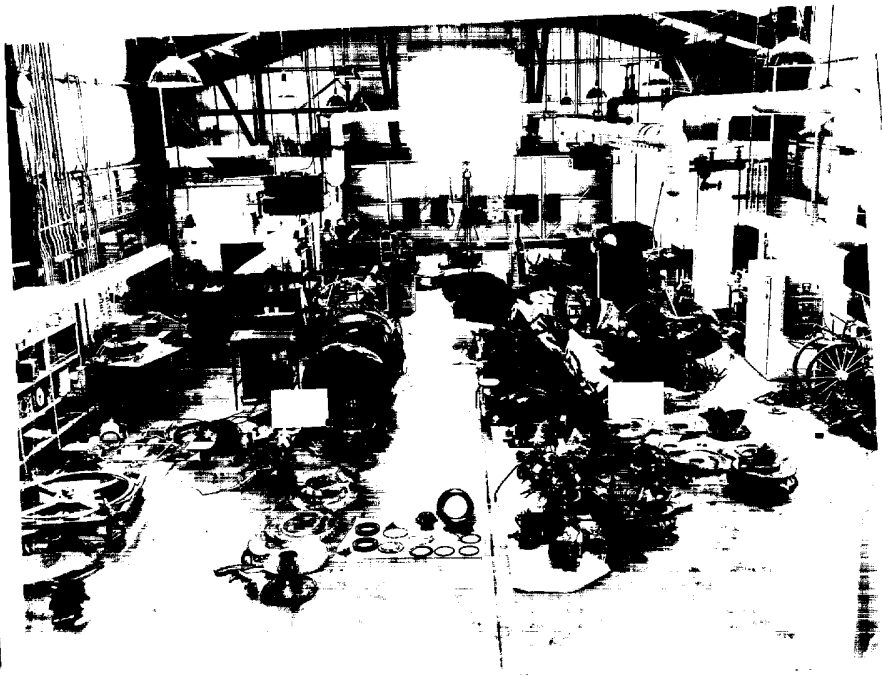

4781

SECRET



4769

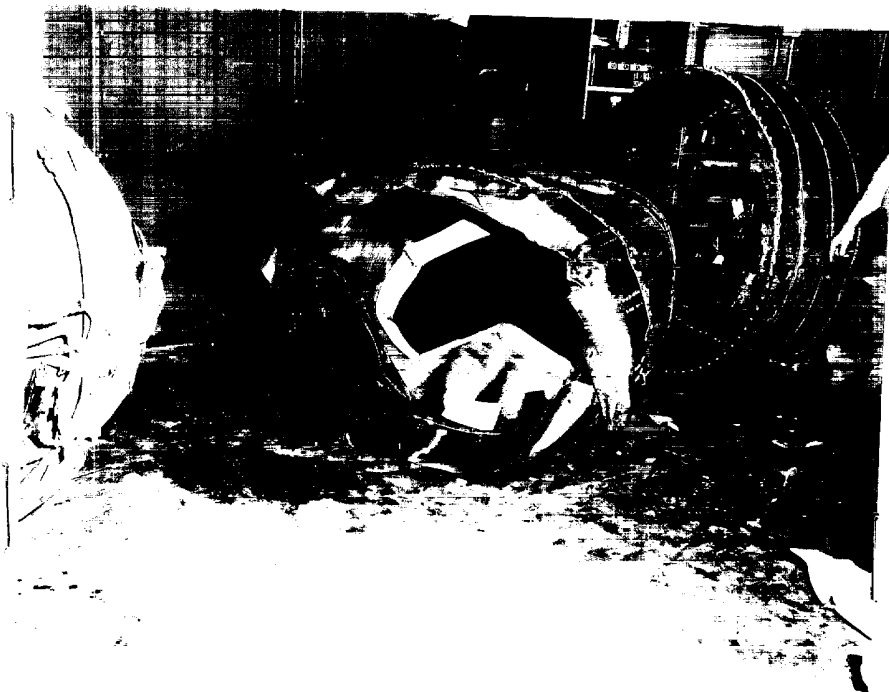

4770

SECRET

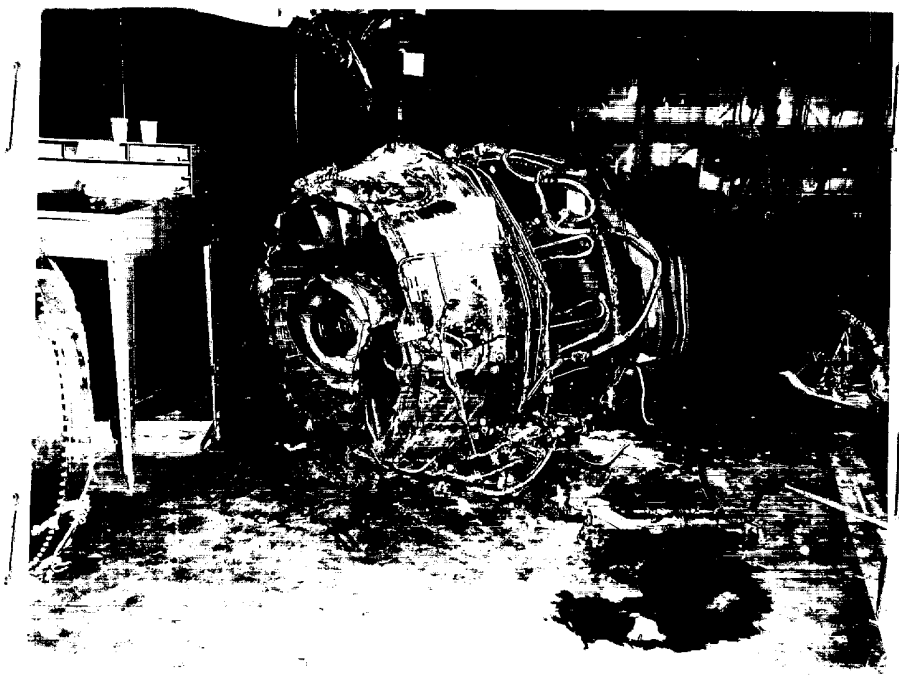

4701



4705

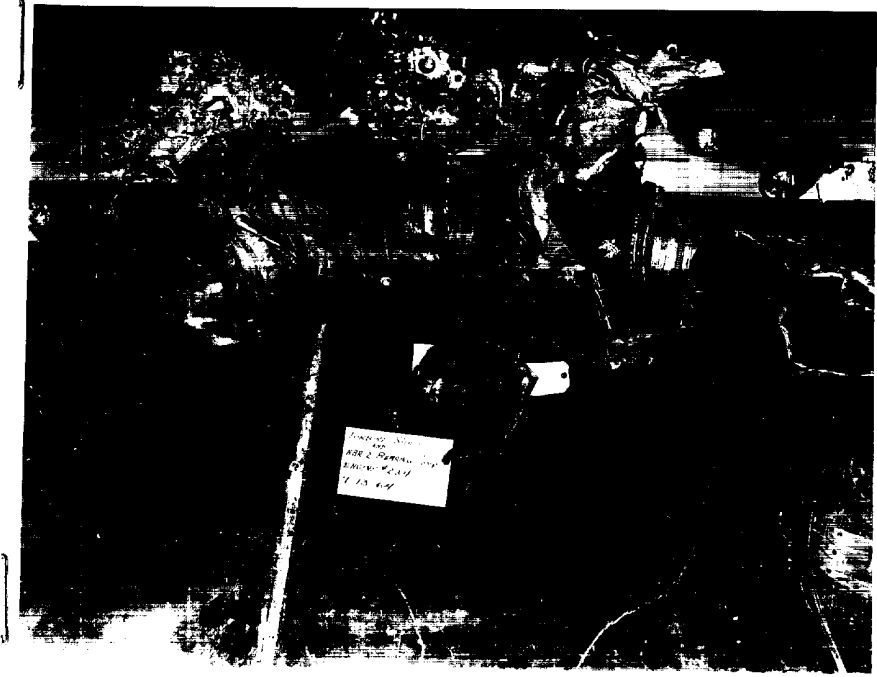

4755

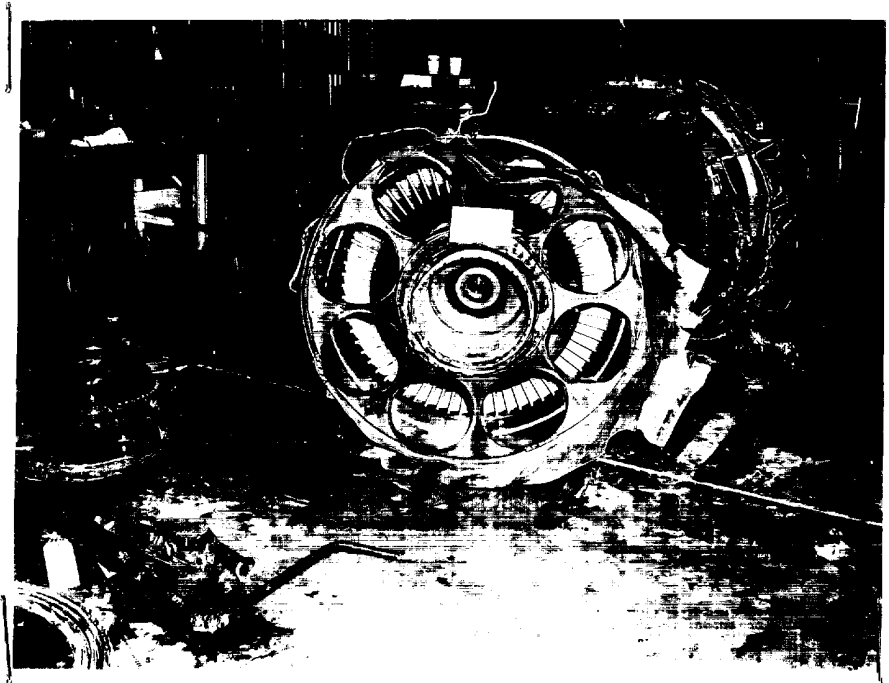

4763

SECRET

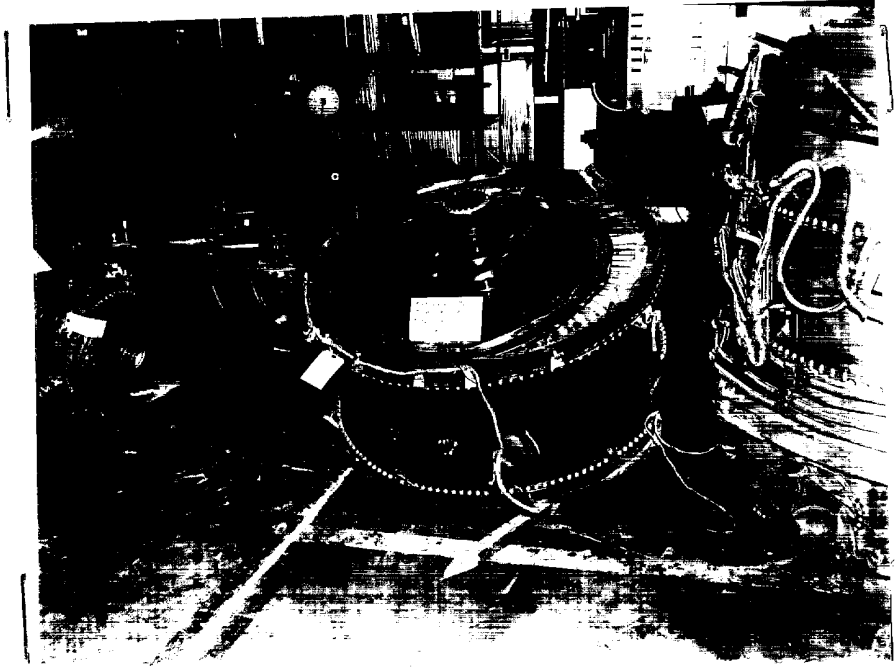

4748



4751

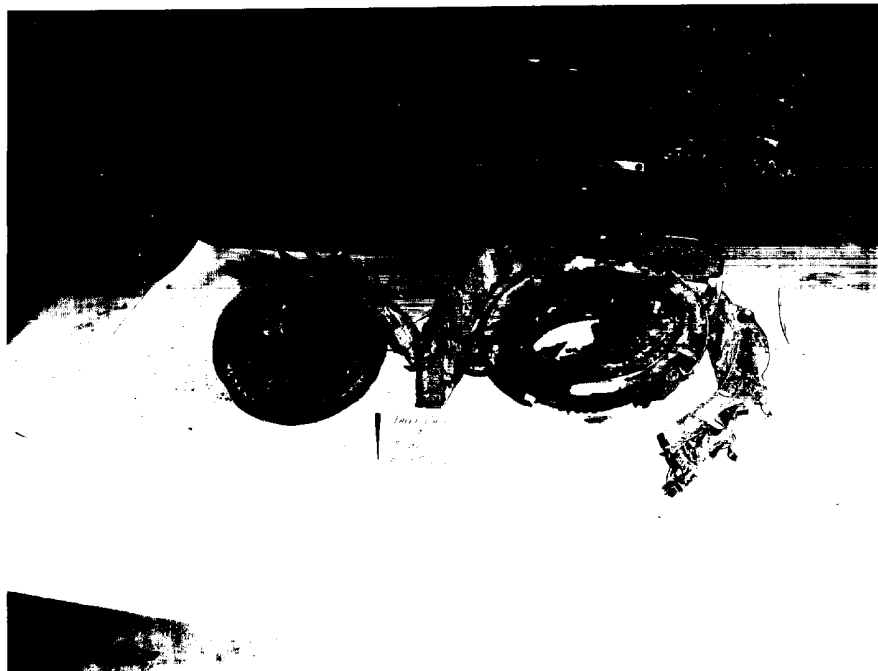

4736

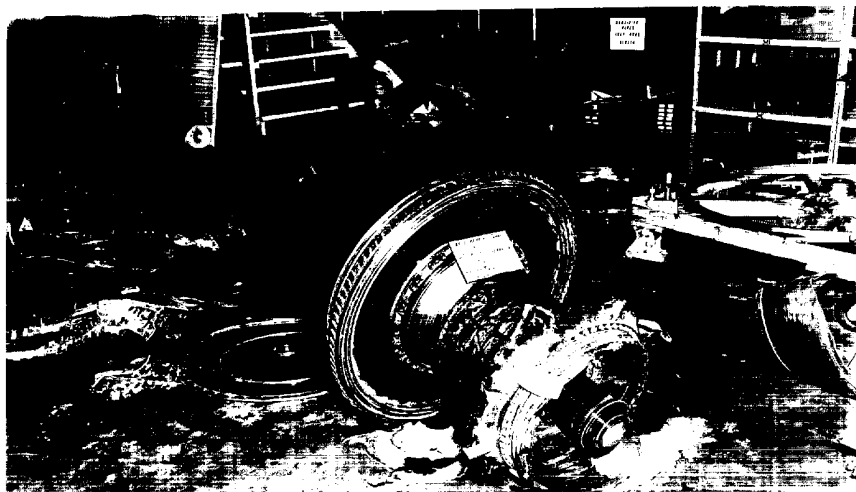

4744



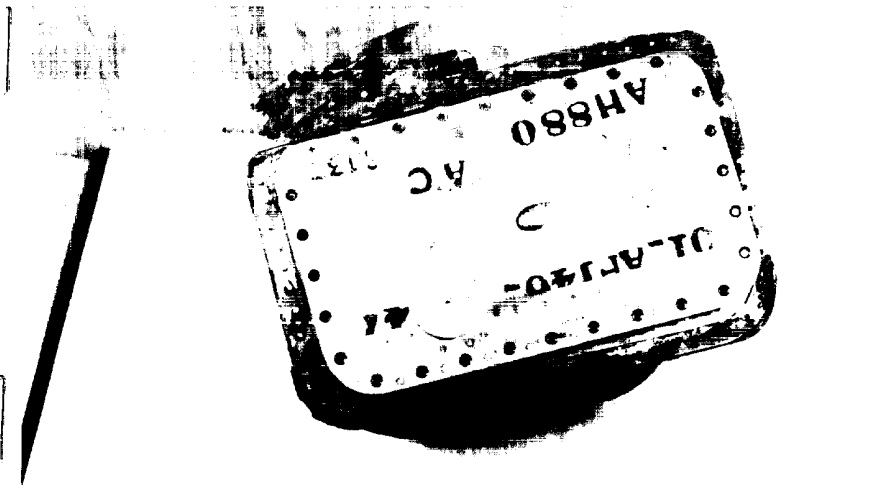

PITCH & YAW  
RATE GYRO  
PACKAGES

4694

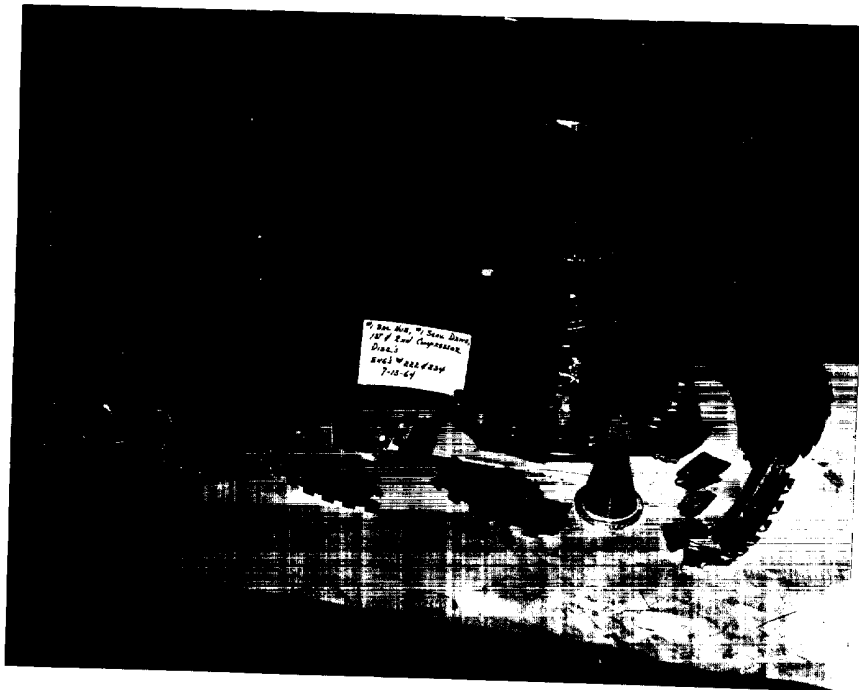

4735



*PITCH & YAW  
RATE GYRO  
PACKAGES*

4592

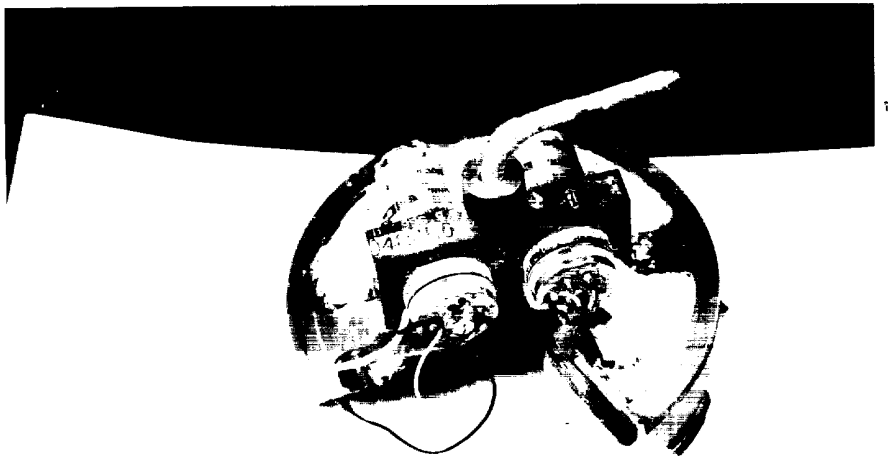

*ROLL RATE GYROS*

4593

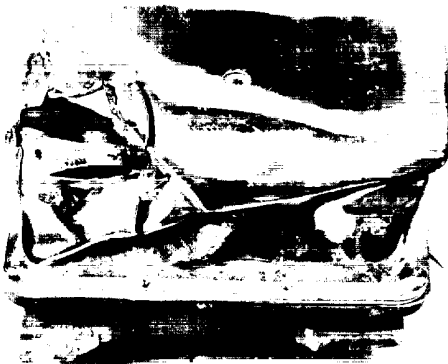

LATERAL  
ACCELEROMETER  
PACKAGE

4550

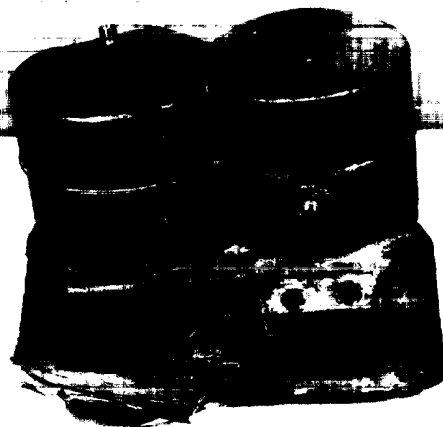

PITCH & YAW  
RATE GYRO  
PACKAGES  
(SHROUD)

4571

**OX CART**      **SECRET**



*ROLL RATE GYROS*

4688

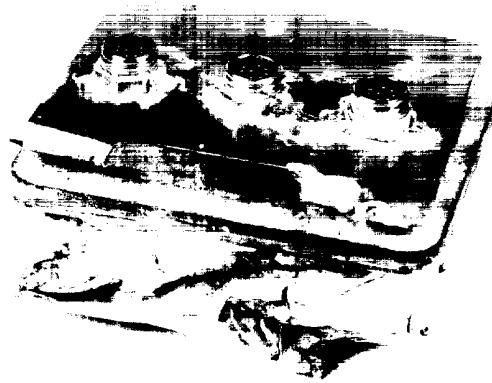

*LATERAL  
ACCELEROMETER  
PACKAGE*

**OX CART**

4689

**SECRET**

OXGART SECRET

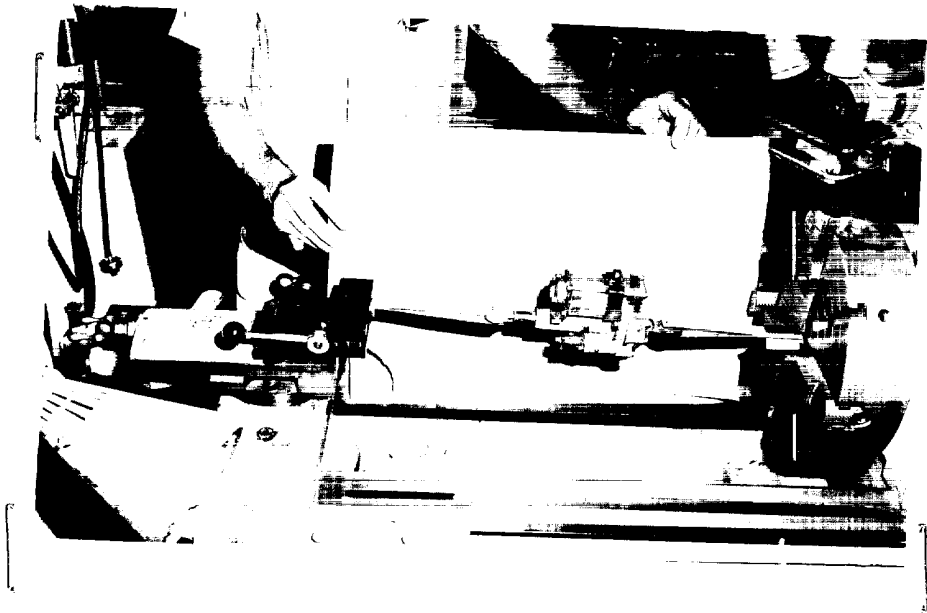

4685

SYSTEM  
INSTR.

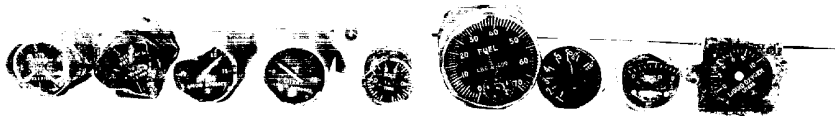

4686

SECRET

**SECRET**

**SECRET**



4678



4682

**SECRET**

**SECRET**

**OXCART SECRET**



4674



4677

**OXCART**

**SECRET**

EXPORT SECRET

Approved For Release 2001/08/29 : CIA-RDP71B00590R000100040001-1



L063

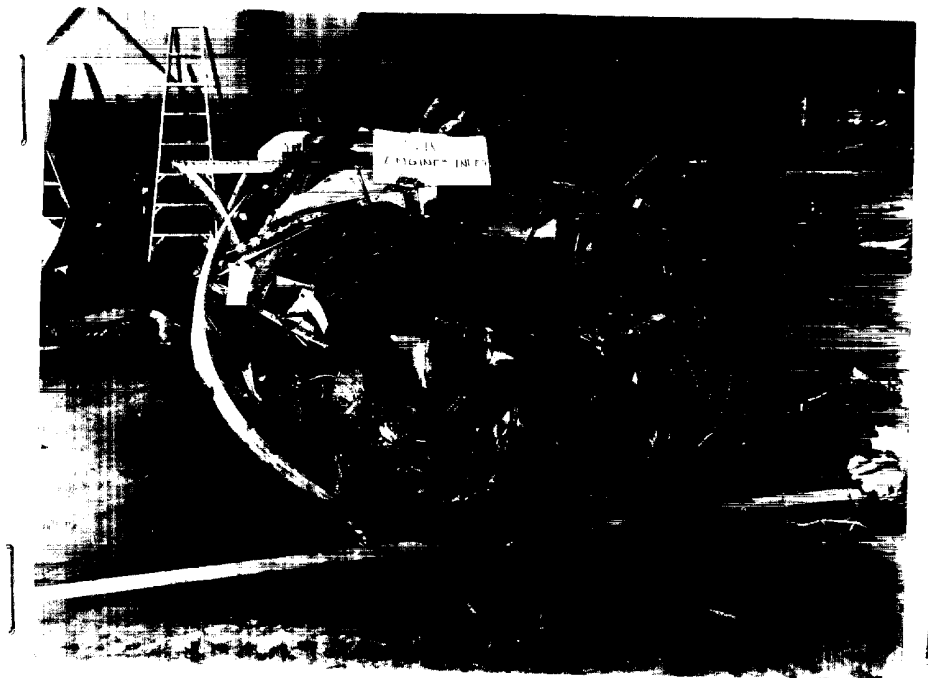

L064

EXPORT SECRET

Approved For Release 2001/08/29 : CIA-RDP71B00590R000100040001-1



OXART SECRET

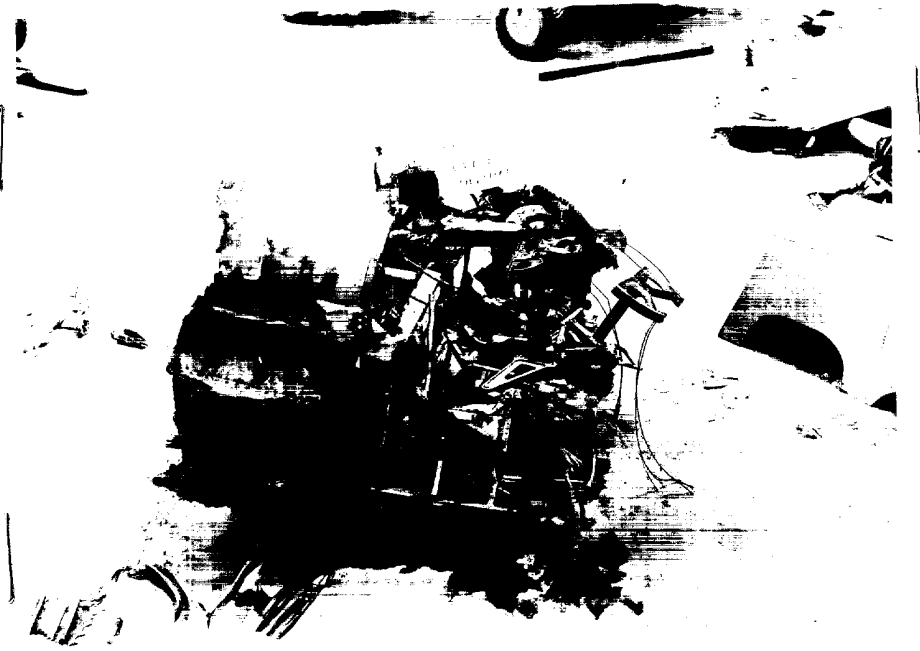

4651

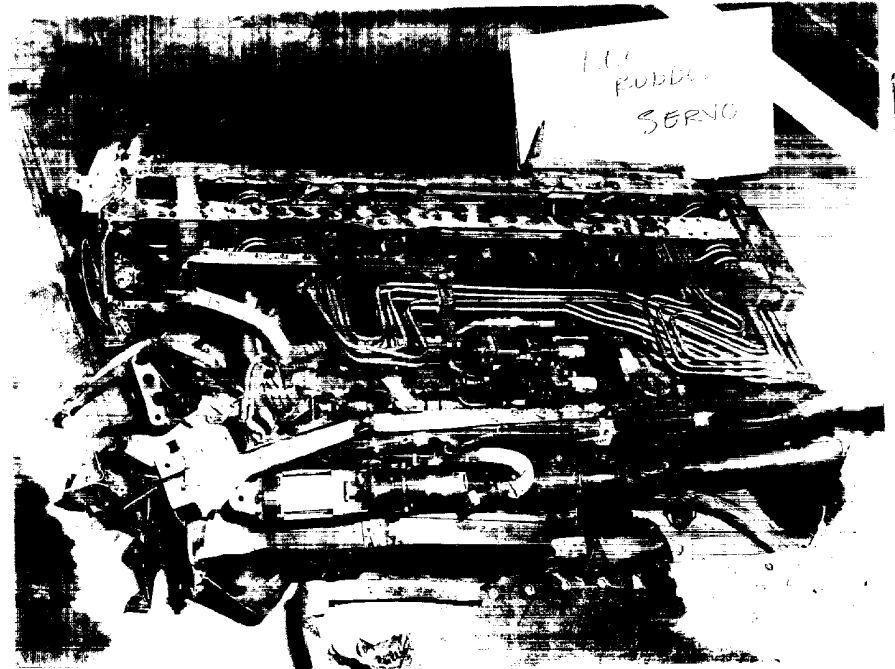

4661

OXART SECRET

**OX CART**

**SECRET**

# SAS GAIN ADJUST PANEL

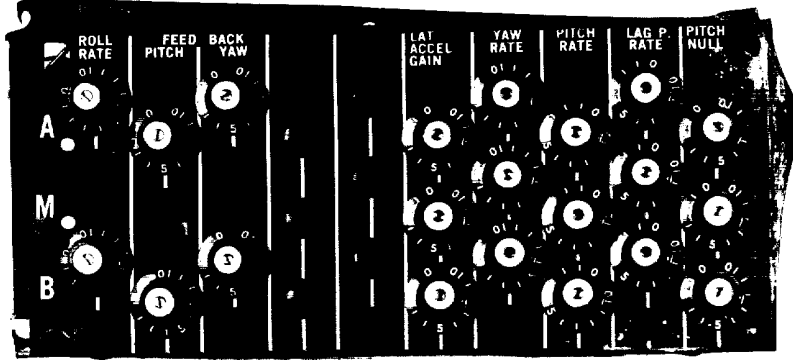

4643

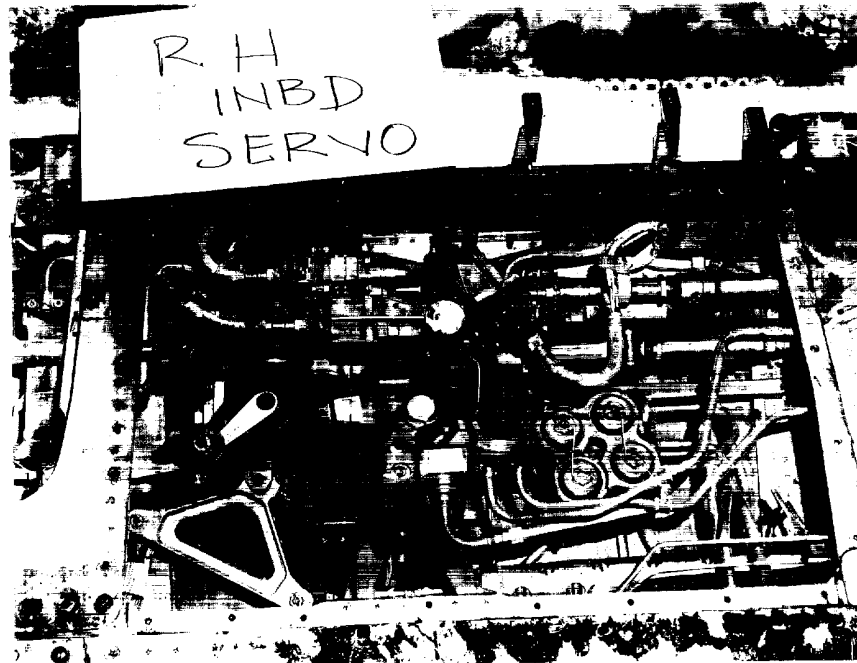

4647

**OX CART**

**SECRET**

~~SECRET~~

**SECRET**



4641



4642

~~SECRET~~

**SECRET**

OXFORD SECRET



4639



4640

OXFORD SECRET

OXOART SECRET

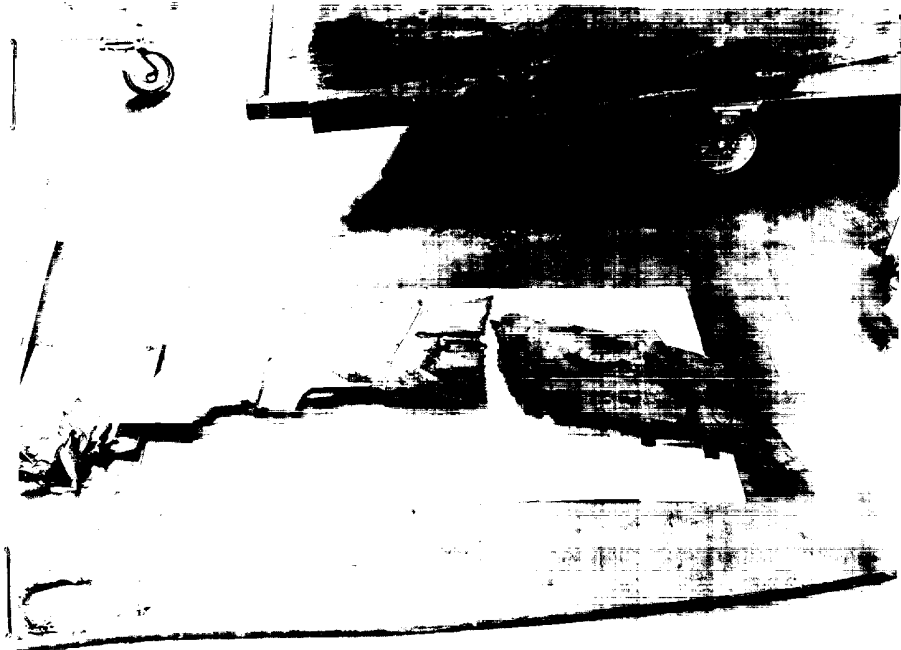

4637



4638

OXOART SECRET

**DXCART**

**SECRET**



4635



**DXCART**

4636

**SECRET**

**OXGART**

**SECRET**

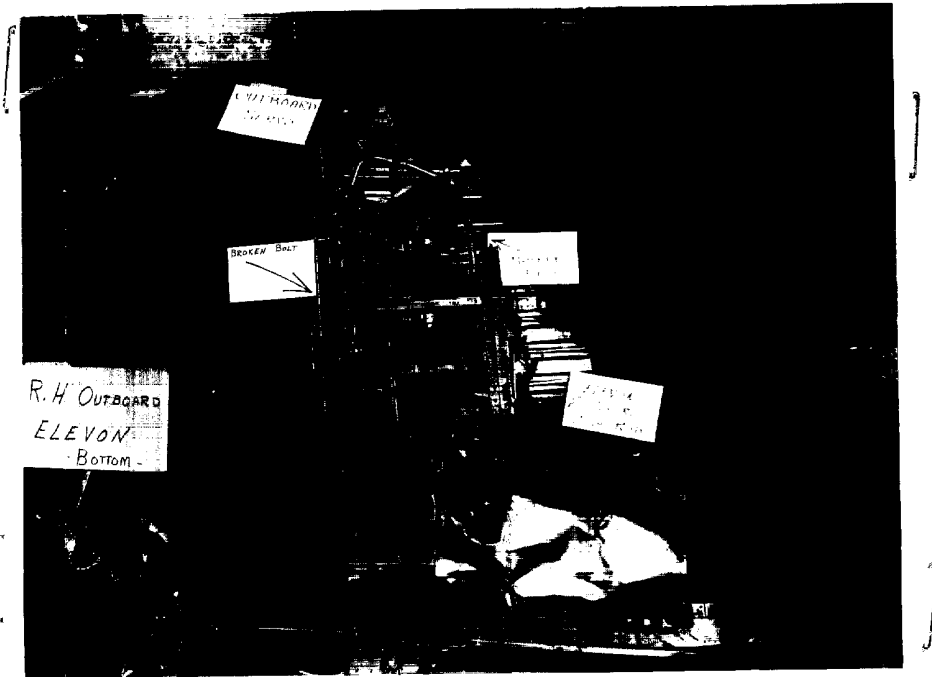

4633

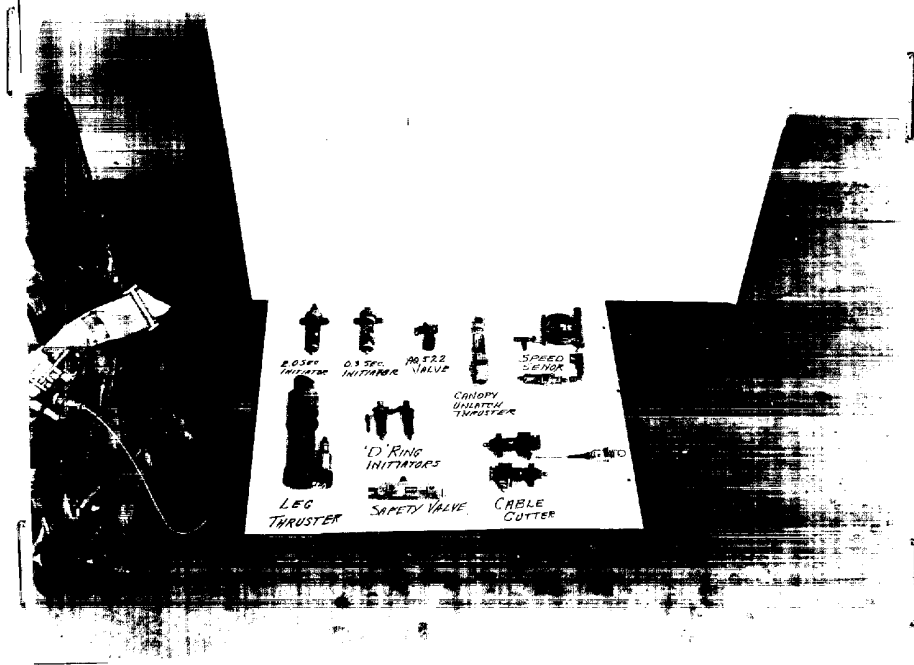

**OXGART**

4634

**SECRET**

**OXGART**

**SECRET**

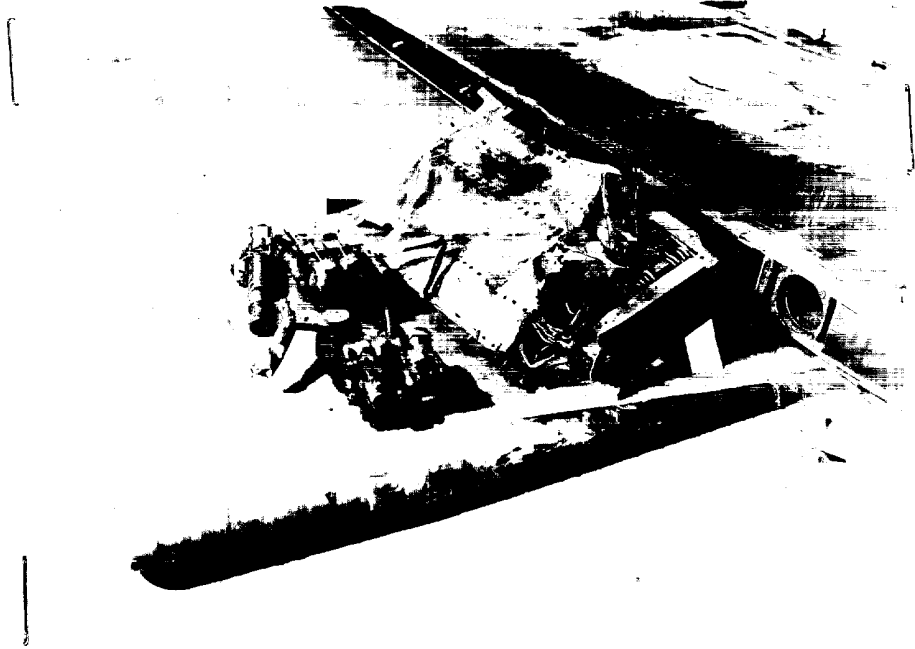

4625



4626

**OXGART**

**SECRET**



**OXCART**

**SECRET**

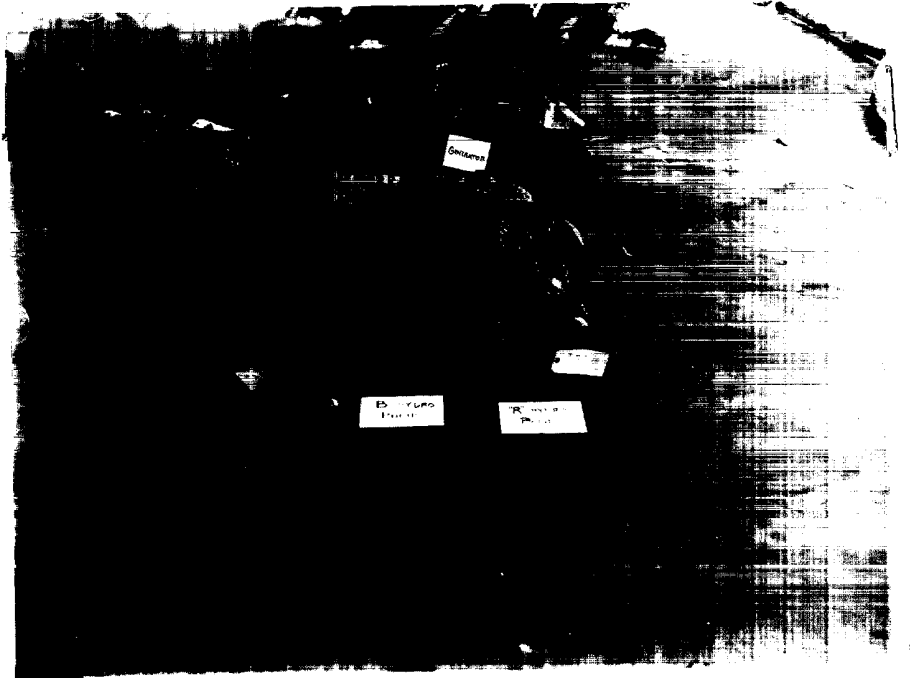

1616

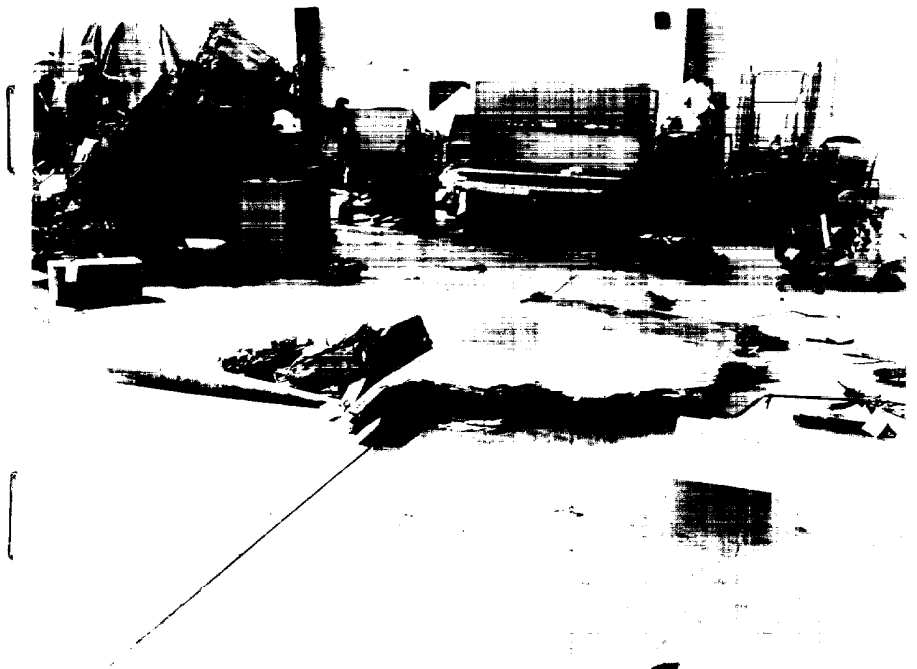

1621

**OXCART**

**SECRET**

**UXCART**

**SECRET**



4608

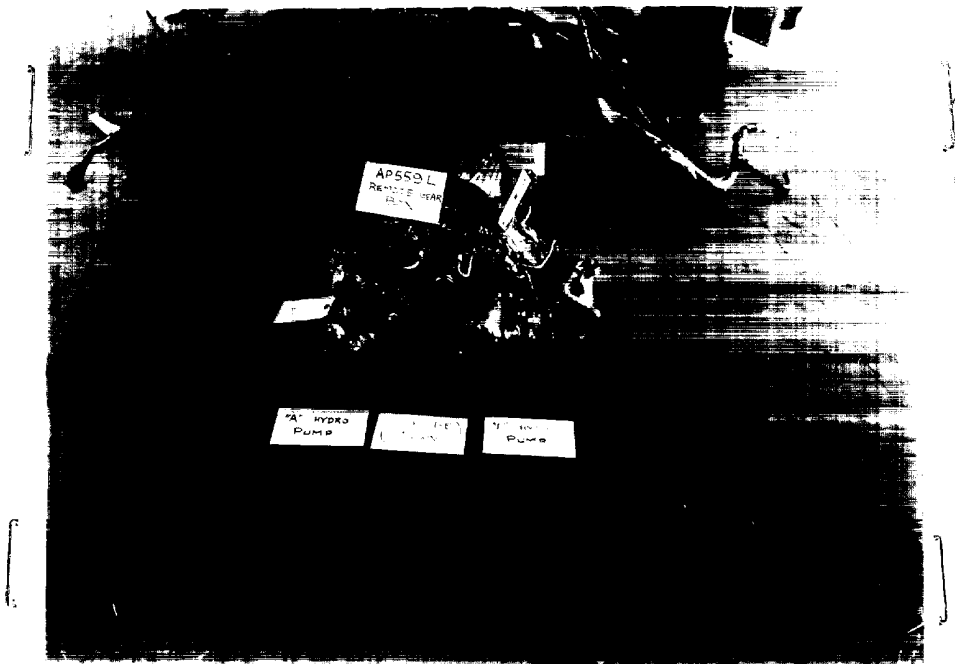

4615

**UXCART**

**SECRET**

**DXCART**

**SECRET**

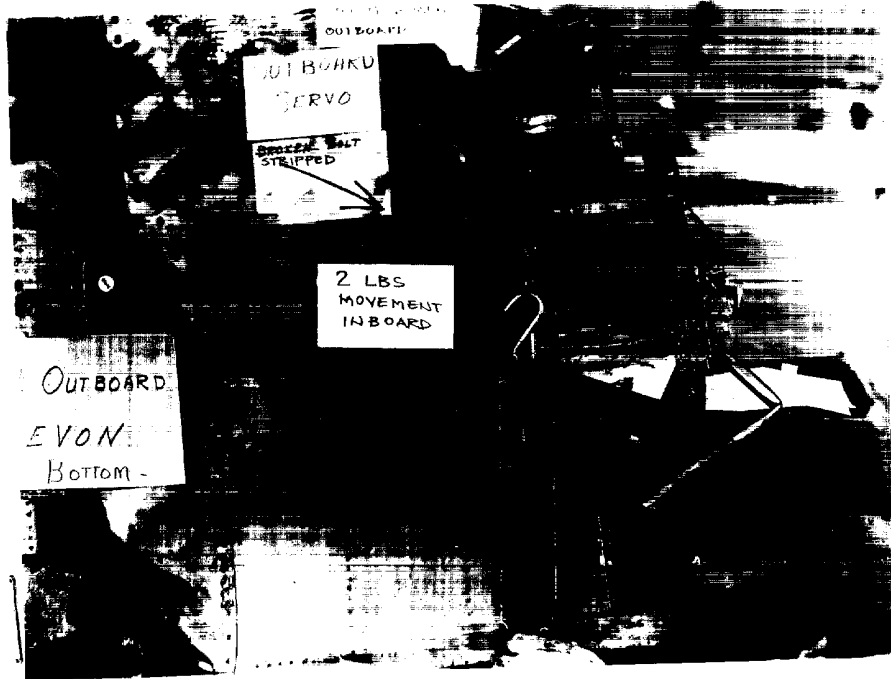

1491

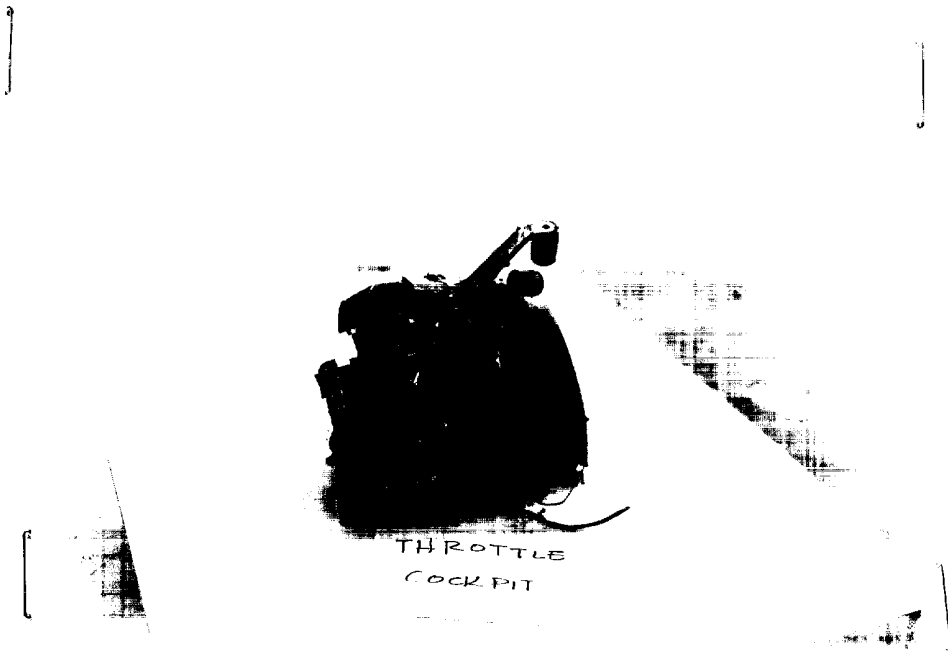

**DXCART**

1492

**SECRET**

**DXCART**

**SECRET**

Approved For Release 2001/08/29 : CIA-RDP71B00590R000100040001-1

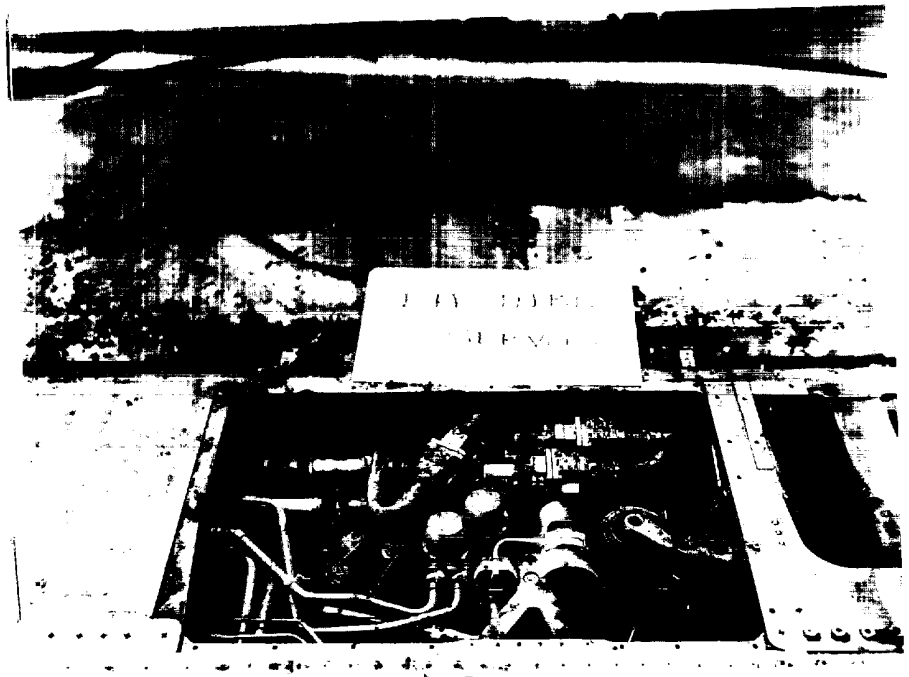
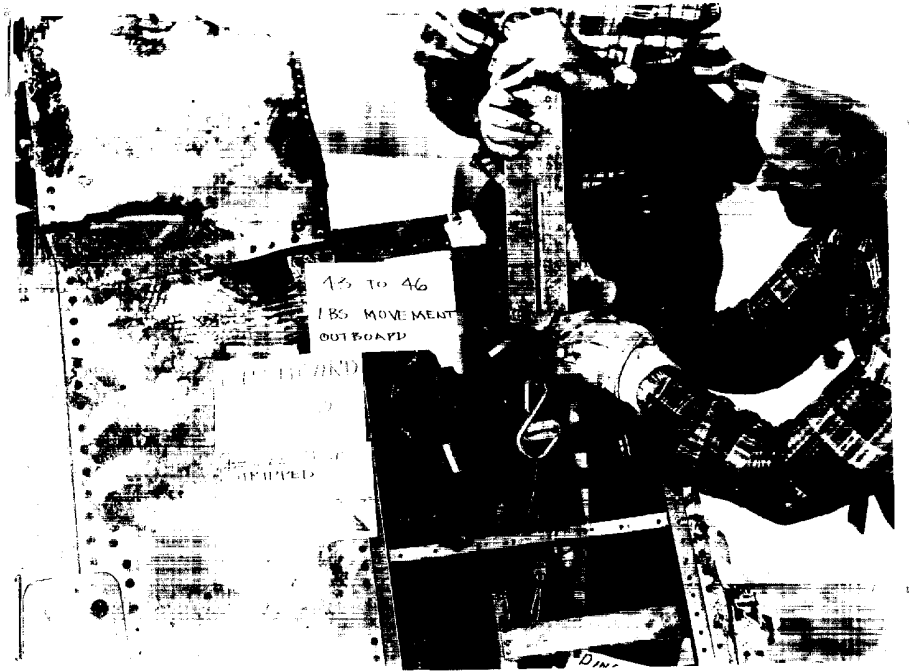

**DXCART**

7500

**SECRET**

Approved For Release 2001/08/29 : CIA-RDP71B00590R000100040001-1

**DXCART**

**SECRET**



1300



**DXCART**

1515

**SECRET**



**OXGART**

4588

**SECRET**



4585



EXCART 4585 SECRET

SECRET

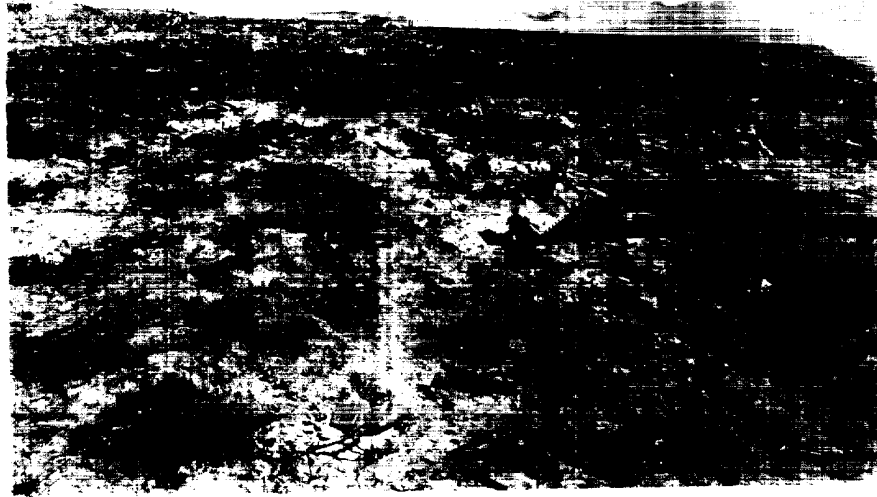

SECRET

SECRET





SECRET



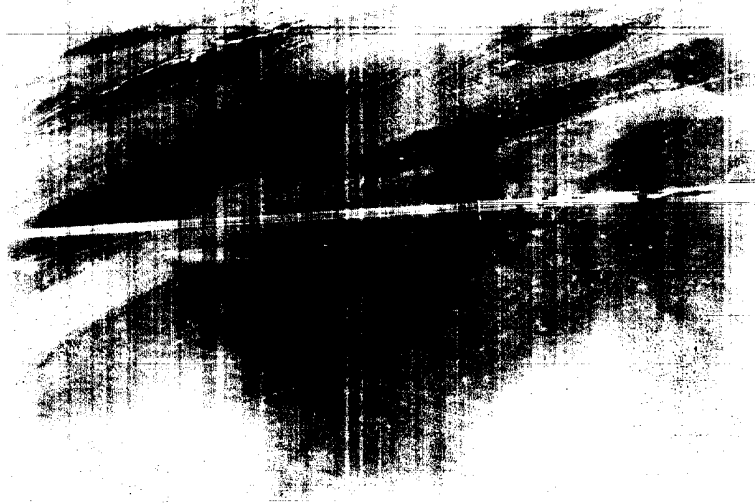
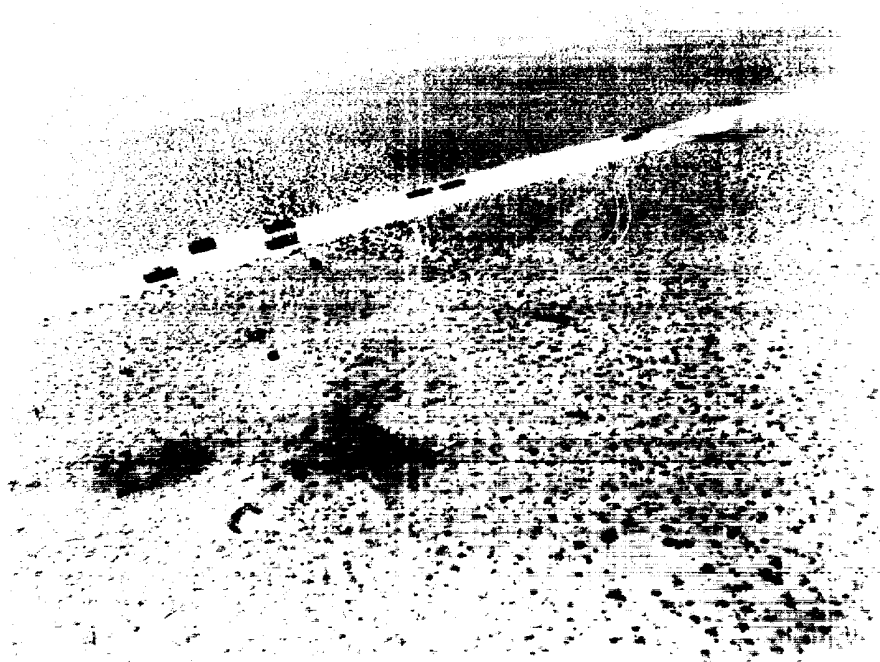

SECRET

SECRET

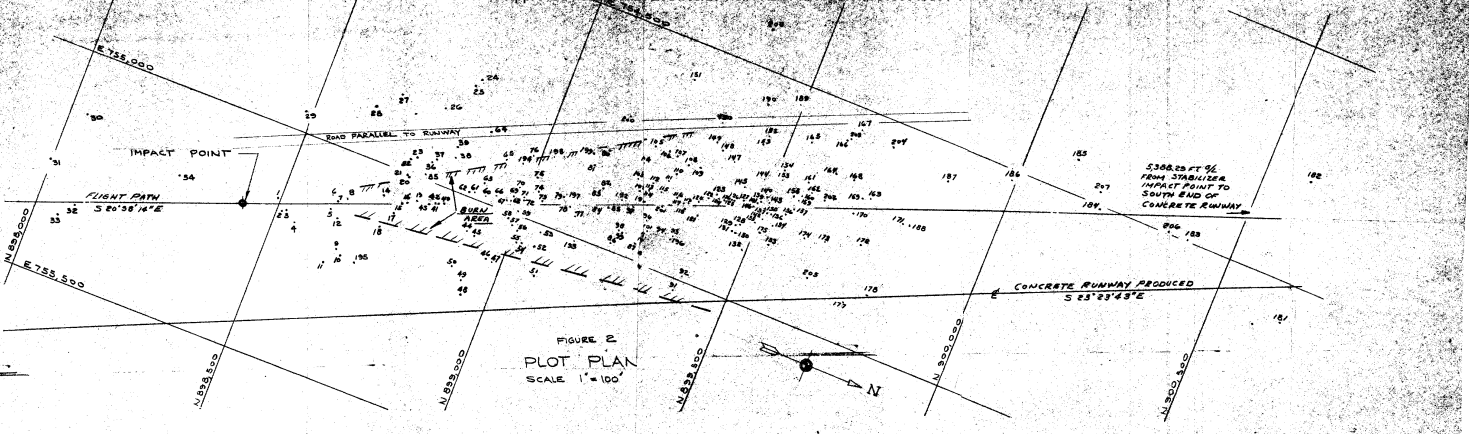



FIGURE 2  
KEY TO PLOT PLAN

- |                                    |  |
|------------------------------------|--|
| 1. Nag. Swivel Joint               | 49. Unidentified Metal                 |
| 2. Turbine Wheel                   | 50. Controls                           |
| 3. Onion Slicer                    | 51. Valve                              |
| 4. 715 Joint                       | 52. Controls                           |
| 5. Tape Recorder                   | 53. Valve                              |
| 6. MIG Activating Cyl.             | 54. Engine Fuel Pump                   |
| 7. Engine Nozzle                   | 55. Controls                           |
| 8. Fuel Structural Valve           | 56. Hydraulic Reservoir                |
| 9. Retract Limit Switch            | 57. AH3411 L. Rudder StubFin           |
| 10. Unidentified Metal             | 58. Controls                           |
| 11. Lock                           | 59. Controls                           |
| 12. Drag Chute                     | 60. Rudder Servo                       |
| 13. Rudder Right Hand              | 61. Ejector Shear Panel<br>RH Outboard |
| 14. Controls                       | 62. 7th Stage Comp. Disc               |
| 15. Nacelle Inlet Lip              | 63. Hydraulic Reservoir                |
| 16. AC, 299 Pulley Bracket         | 64. Rudder Post                        |
| 17. MIG Selector H10               | 65. Onion Slicer                       |
| 18. Fuel Line AH863                | 66. RH Inlet Duct                      |
| 19. Right Rudder Plumbing          | 67. Outboard Aileron Swivel            |
| 20. Hydraulic Relief Valve         | 68. Gudgeon Structure                  |
| 21. Spike Actuator                 | 69. Relief Valve                       |
| 22. Nacelle Swivel Plumbing        | 70. Reservoir Fittings                 |
| 23. Crash Recorder Magazine        | 71. Controls                           |
| 24. Seat (Pilot)                   | 72. Controls                           |
| 25. Seat Rocket ?                  | 73. Controls                           |
| 26. Survo Mech.                    | 74. Hydraulic Pump                     |
| 27. Spur                           | 75. Brake Accumulator                  |
| 28. Chute                          | 76. Controls                           |
| 29. Bag                            | 77. FWD End of Boom Pitot              |
| 30. High Alt Suit Record           | 78. Outboard Cylinder IFR              |
| 31. Dicta Phone Recorder C.        | 79. RH Outboard Servo RH<br>Aileron    |
| 32. Pilot's Info Chart             | 80. Flight Recorder Shelf              |
| 33. Canope                         | 81. Controls                           |
| 34. Tape Recorder                  | 82. Filter                             |
| 35. Outbd. Servo Plumbing          | 83. Valve                              |
| 36. Outbd. Servo Plumbing          | 84. Filter                             |
| 37. Rudder Servo FWD Sec RH        | 85. Control                            |
| 38. R Outer Wing Plumbing          | 86. Hydraulic Pump                     |
| 39. In Crash Rec Sup Spool         | 87. Pressure Relief Valve              |
| 40. Controls                       | 88. Control Part                       |
| 41. Control Pulley                 | 89. Fuel Valve                         |
| 42. L Rudder HYD Plumbing          | 90. AC 241 Control Break               |
| 43. Int. Bleed Actuator            | 91. CIS Unit                           |
| 44. AB Reset Cable<br>IH Rudder    | 92. Main Oil Pump                      |
| 45. Equip Bay Upper Long.          | 93. AB Fuel Control                    |
| 46. WAC Tail Feathers              | 94. IFR Actuator                       |
| 47. AW451 Panel Assy RH            | 95. Hydraulic Valve                    |
| 48. Y Branch Long. of Equip<br>Bay | 96. Fuel HYD Heat Exch.                |

**OXGART SECRET**

FIGURE 2  
KEY TO PLOT PLAN (CONTINUED)

- |   |                                     |
|---|-------------------------------------|
| 97. Gyro Mount  | 149. Hydraulic Reservoir            |
| 98. Auto Pilot  | 150. Invertor                       |
| 99. Turbine Shaft   | 151. MAC Flapper Fitting            |
| 100. Main Gear Box  | 152. Main Fuel Pump                 |
| 101. Diff. Case   | 153. Main Oil Pump                  |
| 102. Rudder Pedal   | 154. LH Inlet                       |
| 103. AB Bird Cage   | 155. After Burner Case              |
| 104. Hydraulic Pump   | 156. Hydraulic Filter               |
| 105. Inlet Center Body  | 157. Controls                       |
| 106. SAS Box  | 158. MDI Gyro                       |
| 107. Invertor   | 159. Air Data Computer              |
| 108. Hydraulic Reservoir  | 160. Spike Main Control             |
| 109. Filter   | 161. Triple Display Indi.           |
| 110. Compressor Disc  | 162. Invertor                       |
| 111. Hydraulic Accumulator  | 163. Throttle Eng End               |
| 112. MDI Door Act.  | 164. Main Gear Strut                |
| 113. Hydraulic Cylinder   | 165. After Burner                   |
| 114. Inlet Spike  | 166. Remote Gear Box                |
| 115. Control Part   | 167. Pitch & Yawl Gyro              |
| 116. Starter Drive Dog  | 168. Reduction Gear Box             |
| 117. Instruments  | 169. Main Wheel                     |
| 118. Rudder Part LH   | 170. Hyd Pressure Reg.              |
| 119. Inlet Structure RH<br>& Main Control Unit                        | 171. #2 Bearing Bull Gear           |
| 120. Controls   | 172. Main Gear & Wheel              |
| 121. SAS Part   | 173. Turbine Wheel                  |
| 122. Generator  | 174. Cockpit Part                   |
| 123. Drift Sight  | 175. Control Part                   |
| 124. Controls   | 176. Generator Control              |
| 125. OXMI/Speed Ind.  | 177. Radio                          |
| 126. SAS Equip.   | 178. Radar Reflector Reference only |
| 127. SAS Equip.   | 179. Engine Part                    |
| 128. Hydraulic Filter   | 180. Engine Turbine                 |
| 129. Controls   | 181. Engine Disc                    |
| 130. Lower Hatch  | 182. Compressor Disc                |
| 131. EGT  | 183. IN2 Bottle                     |
| 132. After Burner Pump  | 184. Wheel                          |
| 133. Controls   | 185. IN2 Bottle                     |
| 134. Controls   | 186. Ballast Bar                    |
| 135. BS954  | 187. Gyro Package                   |
| 136. Center Section Aft   | 188. Ballast Box                    |
| 137. IN2 Bottle   | 189. Oxygen Bottle                  |
| 138. Air Speed Indicator  | 190. Oxygen Bottle                  |
| 139. SAS Equip  | 191. Instrument Panel               |
| 140. CIS Unit   | 192. Hyd Temp Flow Control          |
| 141. Cockpit Assembly   | 193. Control Part                   |
| 142. Turbine Shaft  | 194. Hyd Reservoir Level Guage      |
| 143. SAS Bar  | 195. Control Tube                   |
| 144. Filter   | 196. Engine Macelle                 |
| 145. Spike Rod  | 197. Wing                           |
| 146. Approved For Release 2001/08/29 : CIA-RDP71B00590R000100040001-1 | 198. Wing                           |
| 147. Main Fuel Control  | 200. Strut                          |
| 148. Spike Actuator   | 201. Engine Piece                   |

**OXGART**

**SECRET**

~~OXGART SECRET~~

FIGURE 2  
KEY TO FLOW PLAN (CONTINUED)

- 202. Wing
- 203. Inverter
- 204. Nose Wheel
- 205. Radio
- 206. Oxygen Tank
- 207. Wheel
- 208. Engine Turbine

~~OXGART SECRET~~



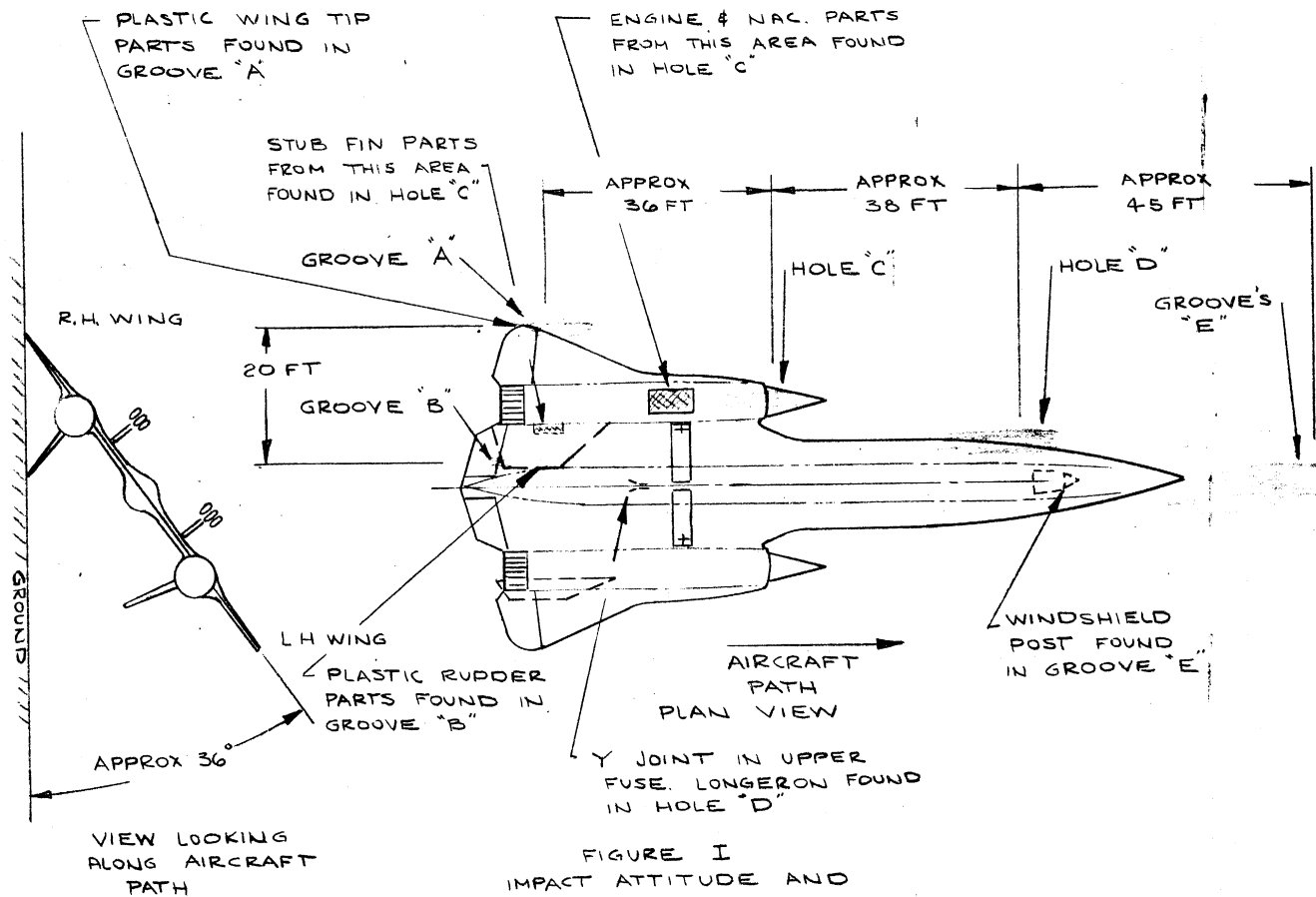
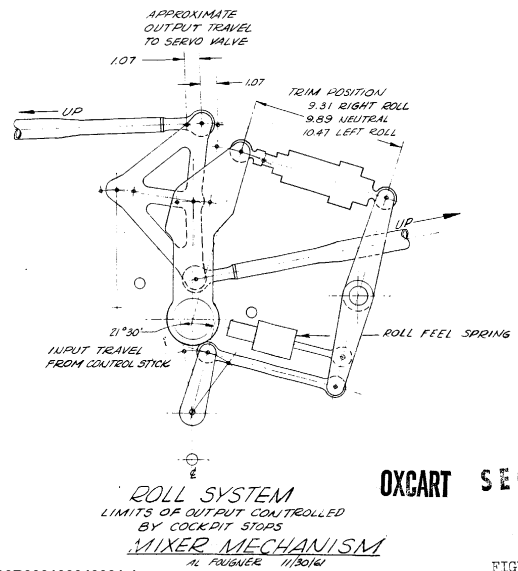
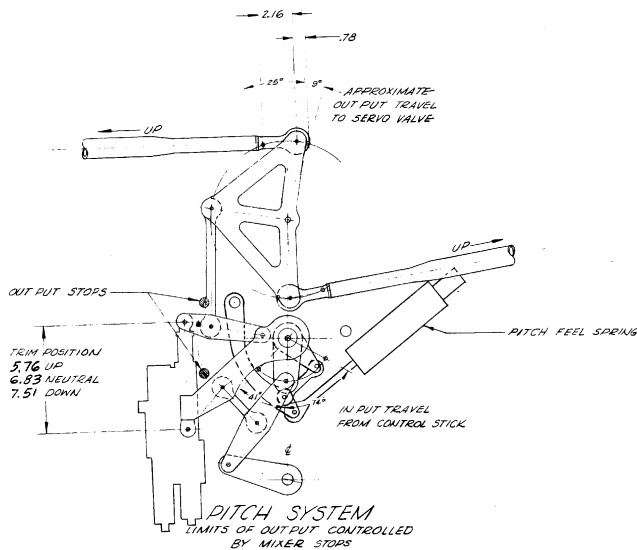
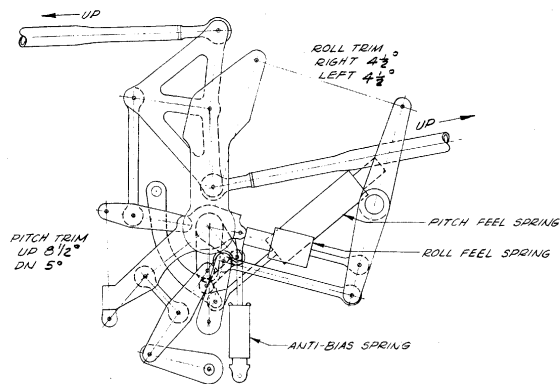

FIGURE I  
IMPACT ATTITUDE AND  
RELATIONSHIP OF AIRCRAFT PARTS  
TO INITIAL IMPACT MARKS

TAB

REVISED PITCH TRIM POSITION 7-16-64  
& ROLL TRIM

**OXGART SECRET**



**OXGART SECRET**

Approved For Release 2001/08/29 : CIA-RDP71B00590R000100040001-1

# ELEVON POSITIONS FOR TRIMMED FLIGHT RT. OUTBOARD ELEVON FAILED

$V_0 = 200 \text{ KEAS}$   
 $W = 69000 \text{ LBS}$   
 $C.G. \approx 20\%$   
 $M \approx .3$

SYN 133 TRIM ACTUATOR ON IMPACT

$\delta$  DEG.

2 1/2" DIFFERENTIAL  
 ELEVON, MECH STOP

RT. INB'D

NOTE: SHIFT LINES TO  
 LEFT .425" FOR EACH  
 1% FWD. SHIFT IN C.G.  
 WT +  $M_2$  EFFECTS ARE  
 NEGLIGIBLE

BEYOND MECHANICAL STOP  
 LINES, AIRCRAFT STILL TRIMMED  
 IN 1 1/2" FLIGHT BUT NOT  
 CONTROLLABLE IN ROLL. THE  
 STEADY ROLL RATE WITH THE  
 RIGHT OUTBOARD HARDOVER  
 WOULD BE APPROXIMATELY  
 37 %/SEC.

8.7 DEG.

T. OUTB'D

RT. INB'D

T.E. DN

$\delta$  OF RT. OUTB'D  $\approx$  DEG.

FIGURE 8

OXGART SECRET

OXCAR SECRET

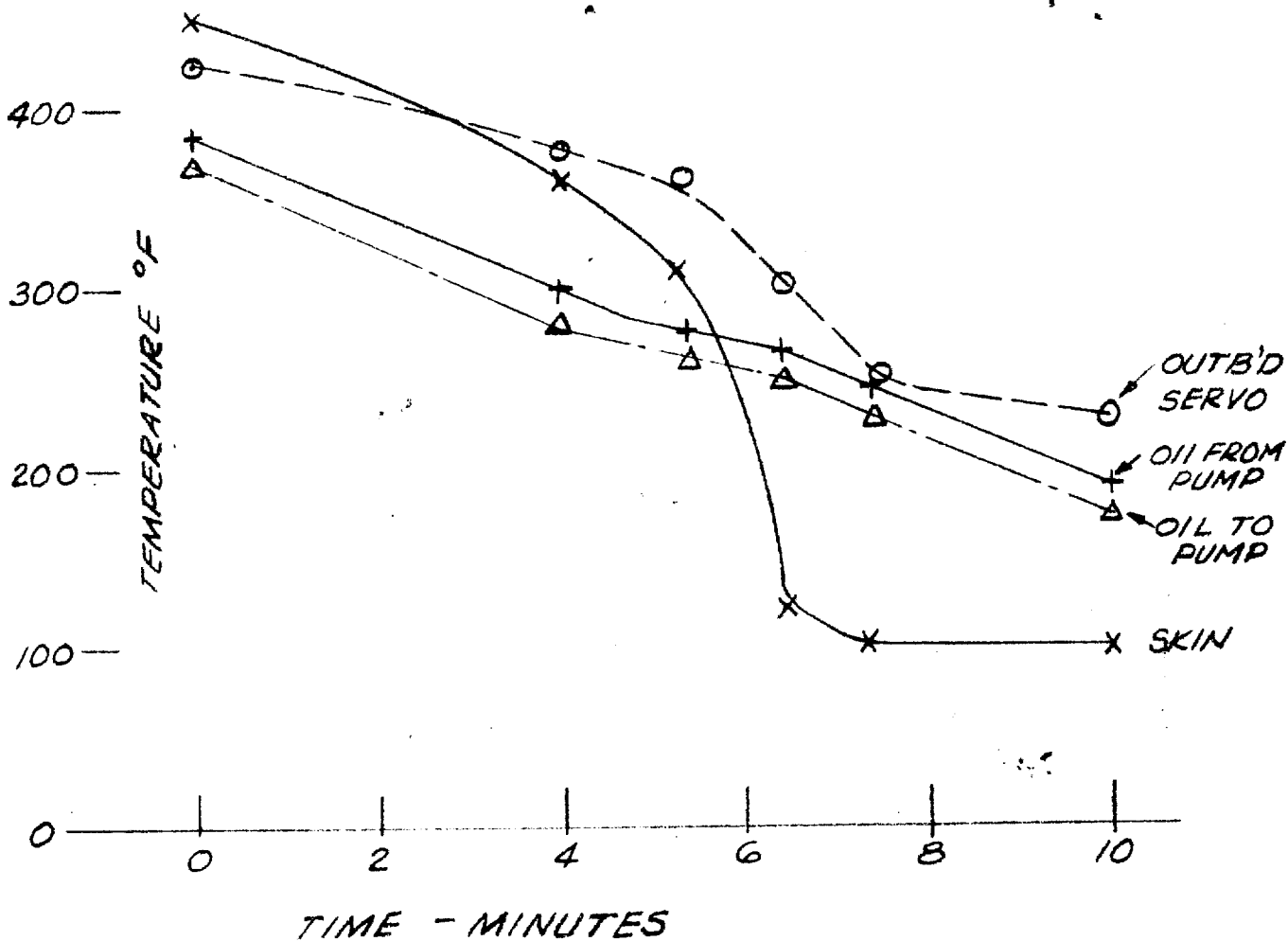
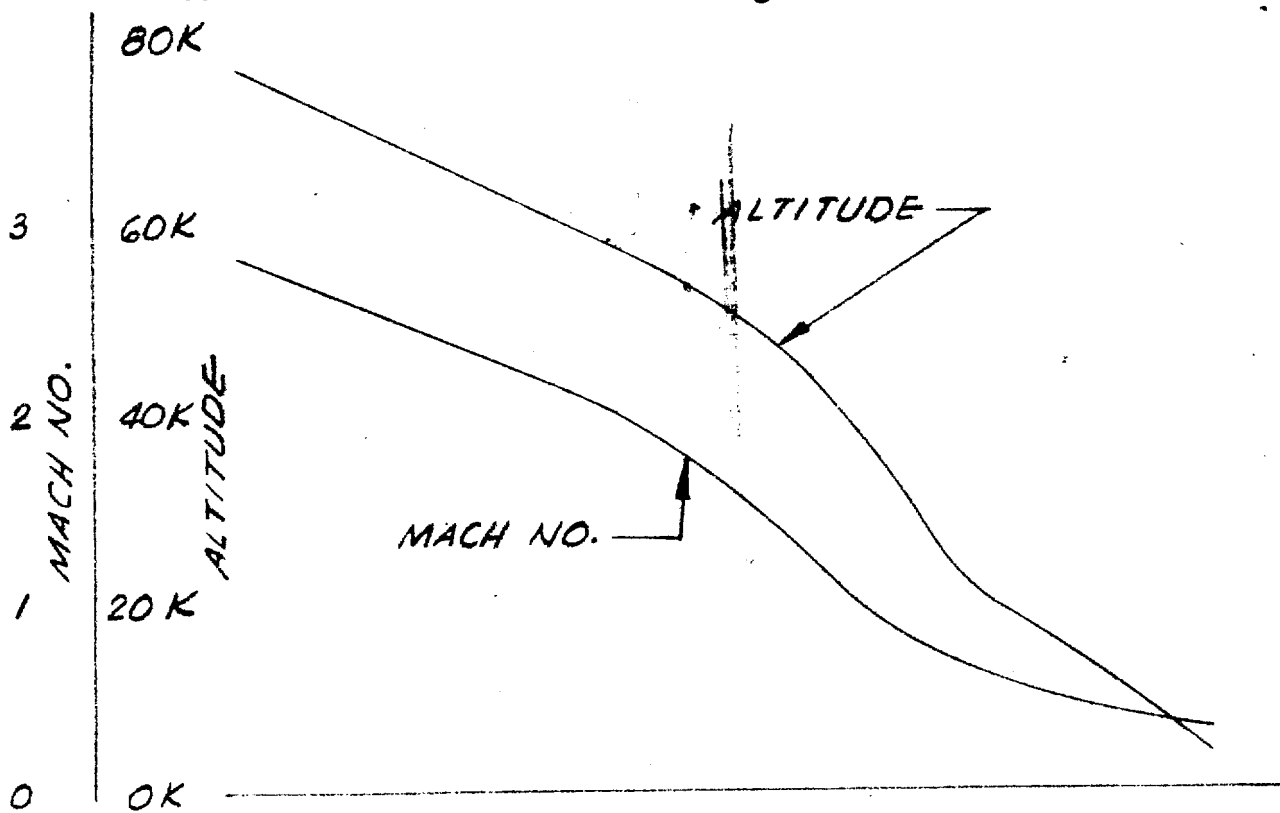

OXCAR SECRET

FIGURE 7

**SECRET**

*D1192*

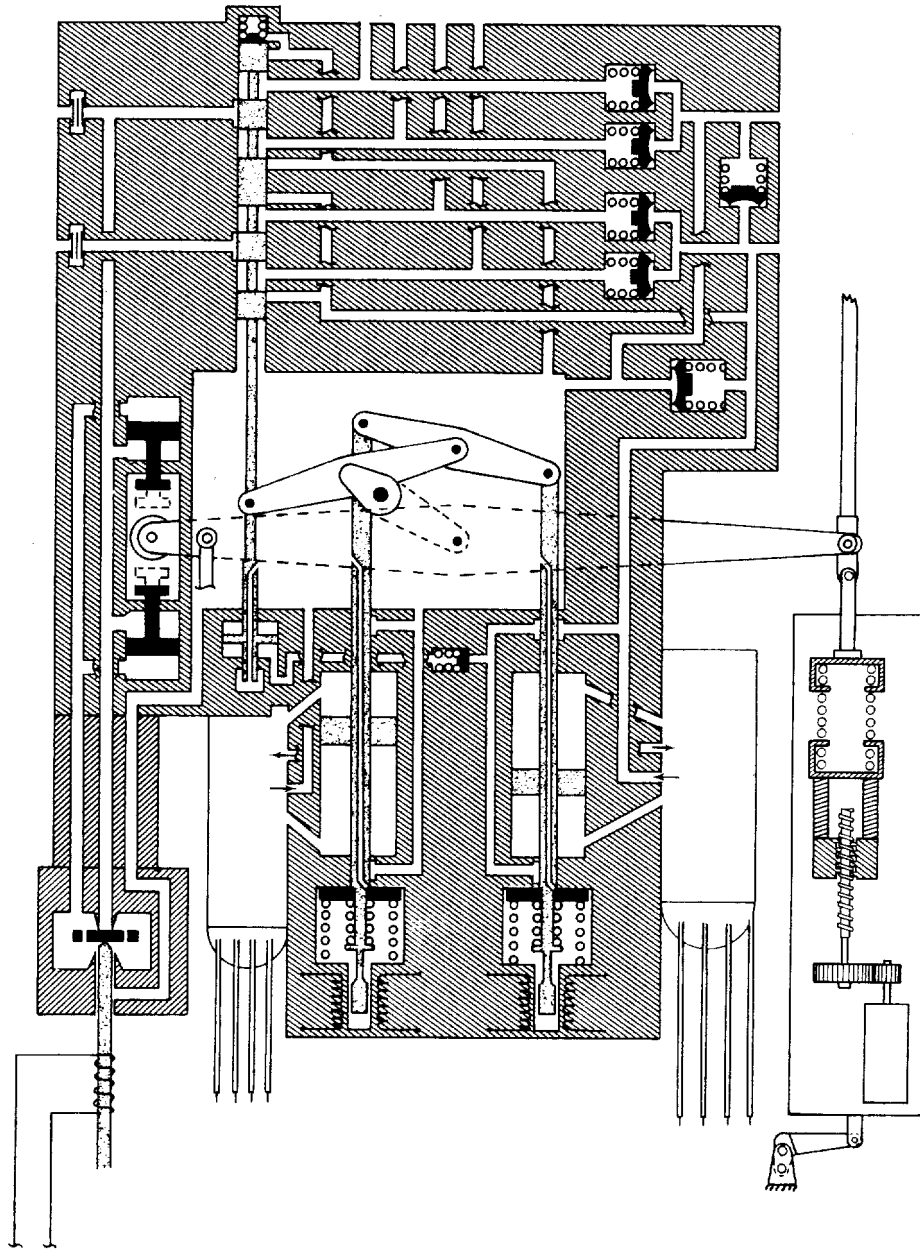

148110-2-1-4  
SERVO - RUDDER FIGURE 5

**SECRET**

**OX CART SECRET**

FLIGHT SIMULATOR TEST USING THE TWO  
INBOARD SERVOS FROM AIRPLANE 133

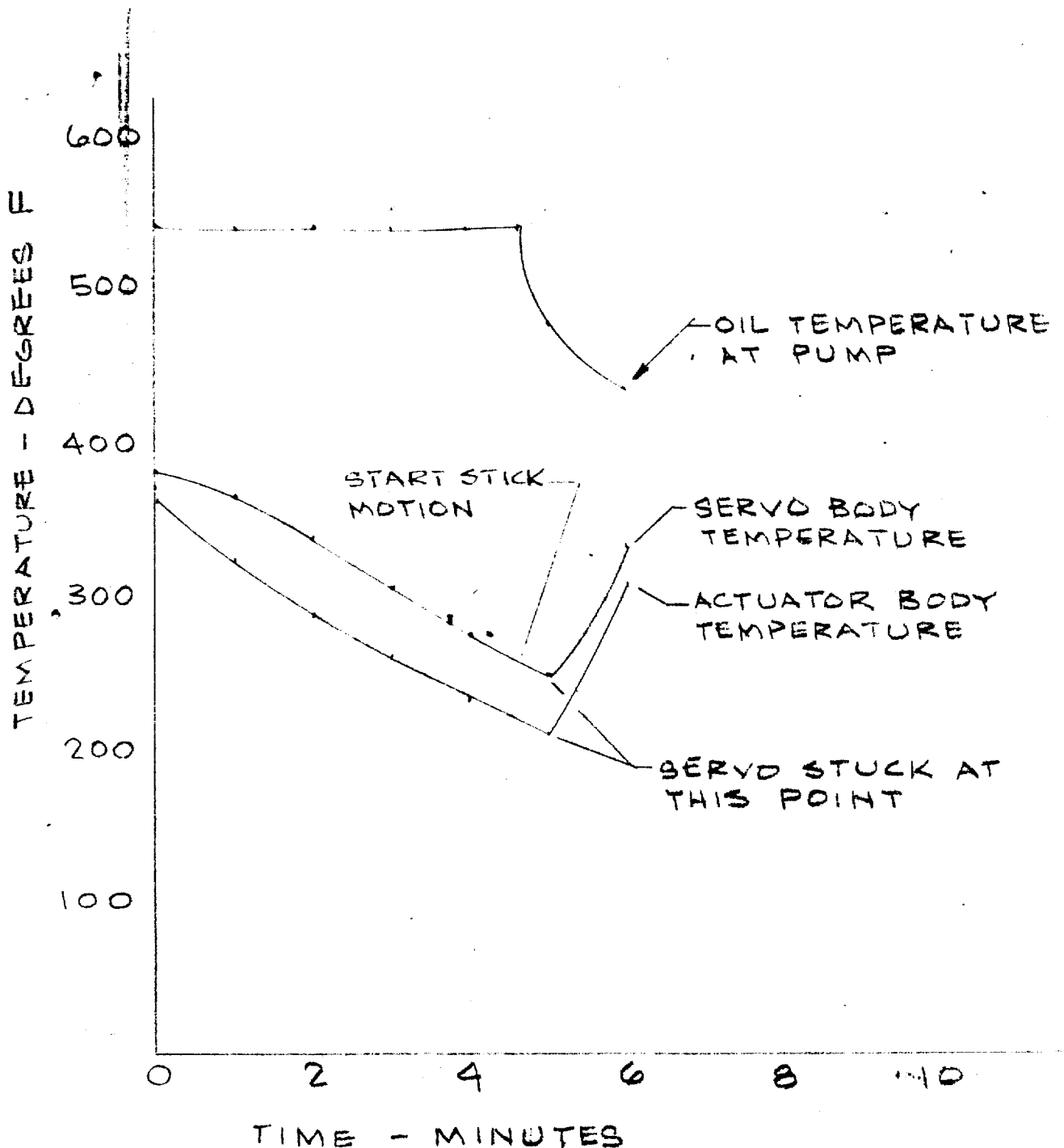

**OX CART SECRET**

FIGURE 6

**OX CART SECRET**

Approved For Release 2001/08/29 : CIA-RDP71B00590R000100040001-1

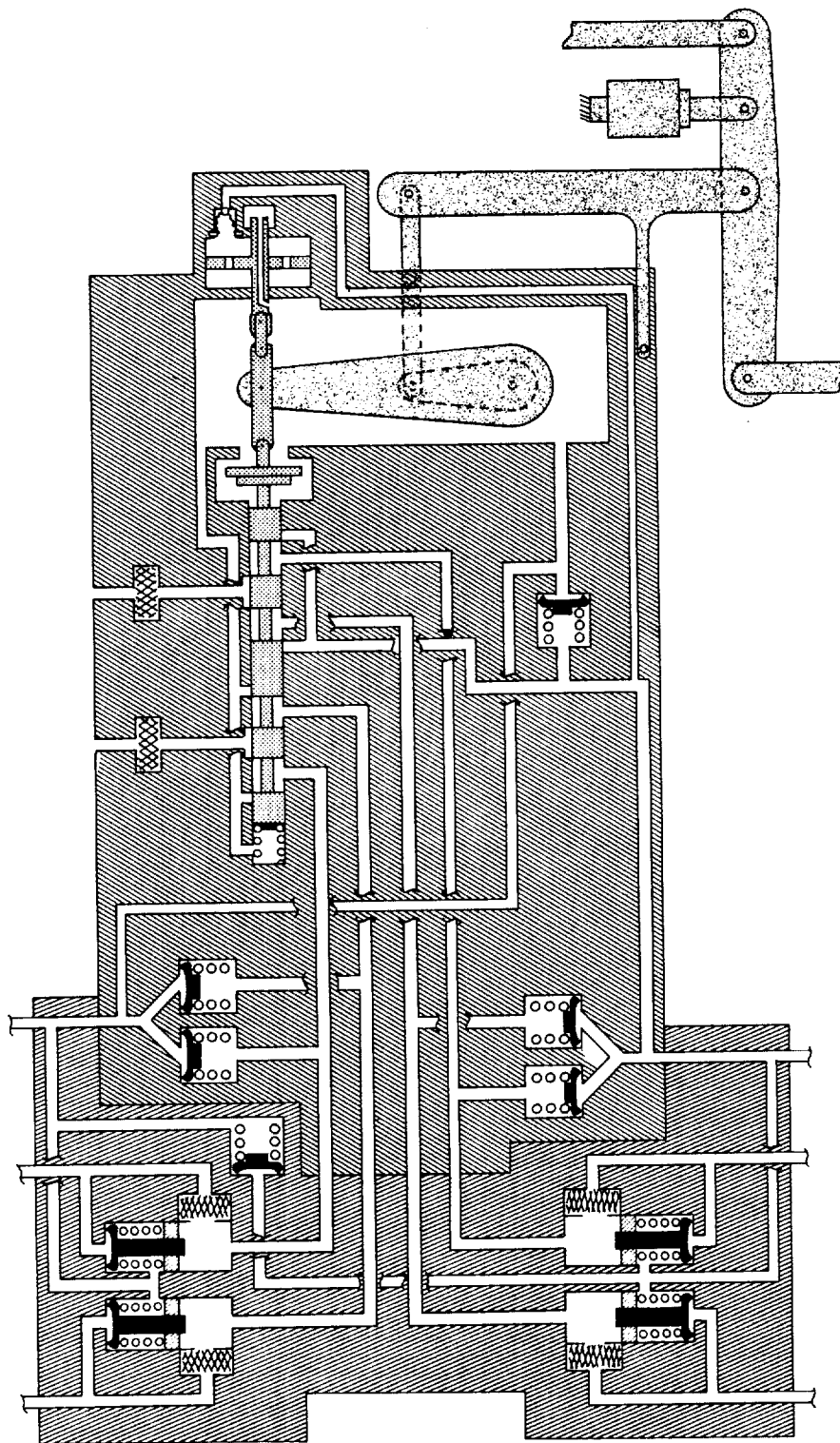

MAPLE-2-C-3  
SERVO - OUTBOARD ELEVON FIGURE 4

Approved For Release 2001/08/29 : CIA-RDP71B00590R000100040001-1

**OX CART SECRET**





ELEVON SYSTEM MECHANICAL SCHEMATIC  
 V. Sorenson 12-3-61

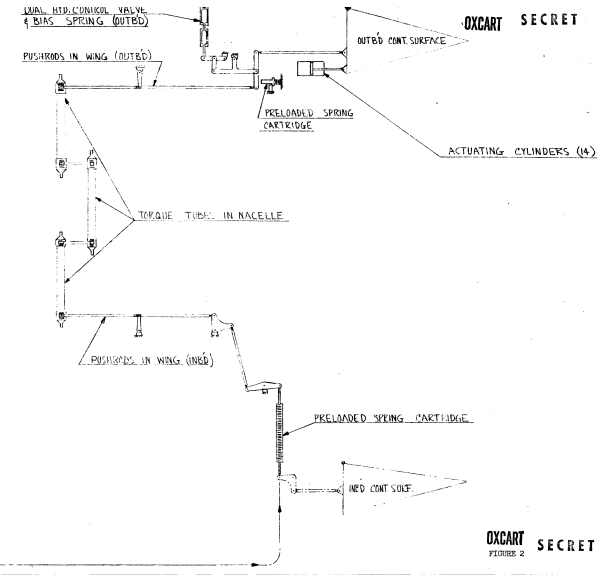
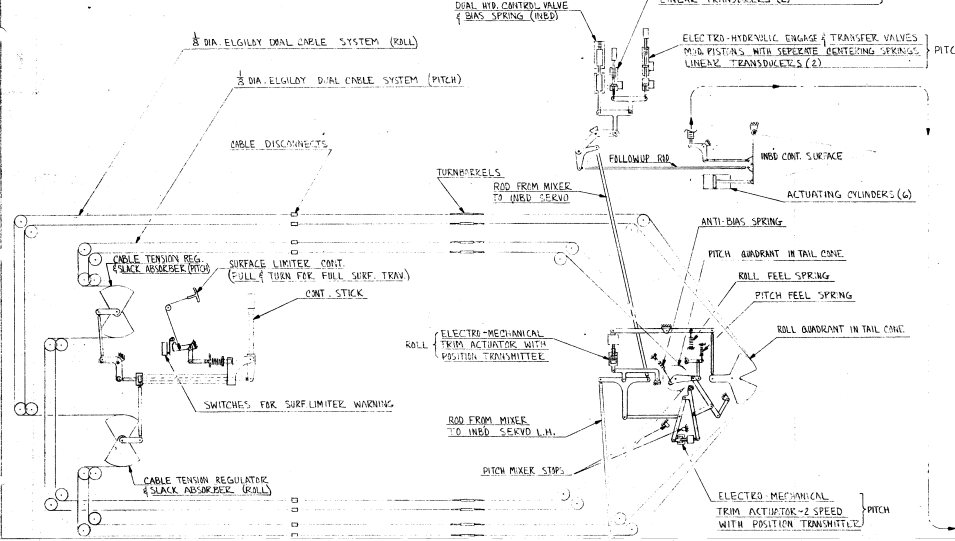

OXART SECRET

OXART SECRET  
 FIGURE 2

RUDDER SYSTEM MECHANICAL SCHEMATIC

# RUDDER SYSTEM MECHANICAL SCHEMATIC

V. SORENSEN (2-5-61)

Approved For Release 2001/08/29 : CIA-RDP71B00590R000100040001-1

SERVO SURFACE LIMITER  
SOLENOID VALVE

SERVO SURFACE LIMITER  
CYLINDERS

ACTUATING CYLINDERS  
(2 EACH SIDE)

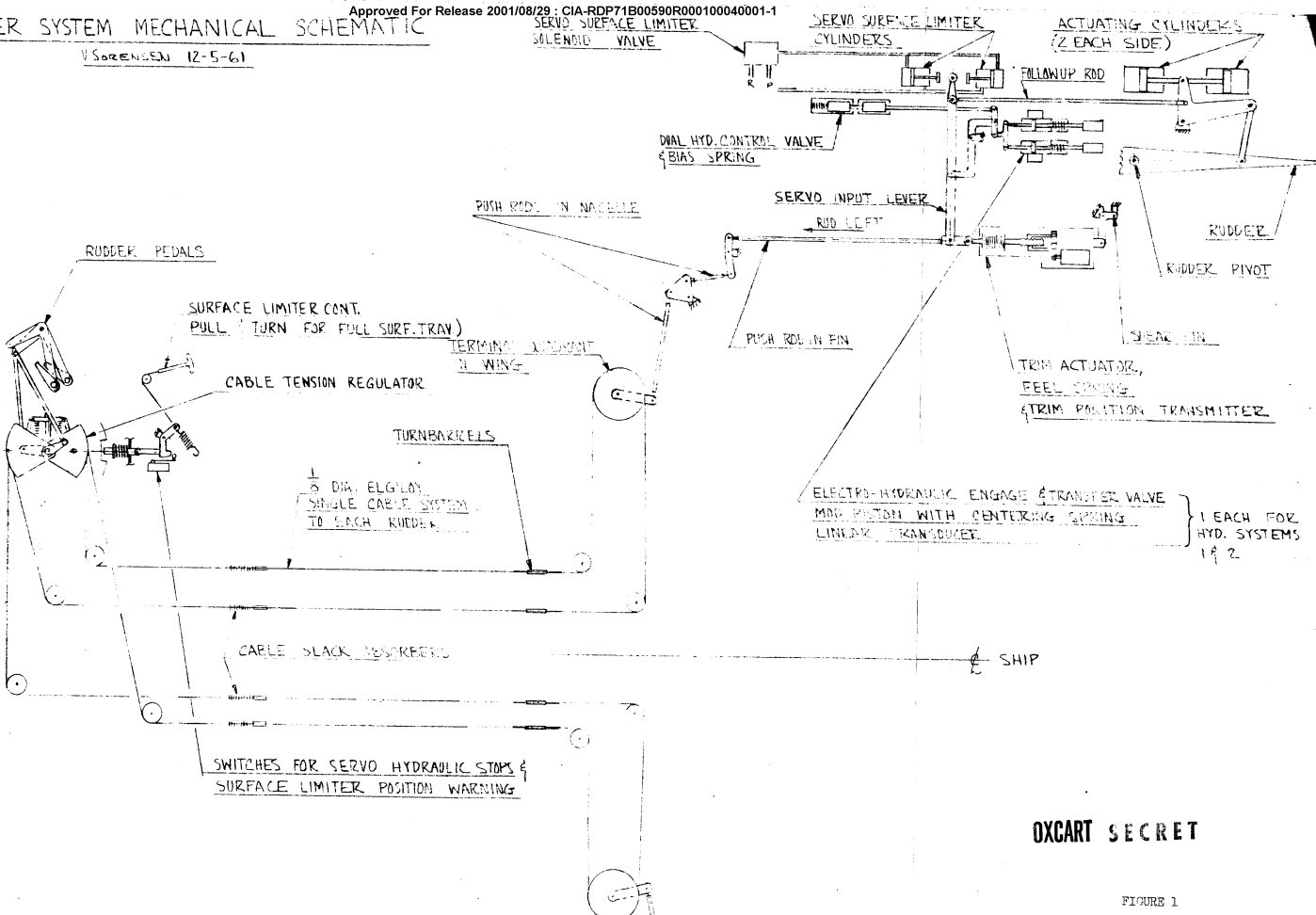

OXFART SECRET

FIGURE 1

Approved For Release 2001/08/29 : CIA-RDP71B00590R000100040001-1