

CENTRAL INTELLIGENCE AGENCY

INFORMATION REPORT

This Document contains information affecting the National Defense of the United States, within the meaning of Title 18, Sections 793 and 794, of the U.S. Code, as amended. Its transmission or revelation of its contents to or receipt by an unauthorized person is prohibited by law. The reproduction of this form is prohibited.

SECRET
SECURITY INFORMATION

25X1

COUNTRY	USSR (Kalinin Oblast)	REPORT	
SUBJECT	Rocket and Aircraft Development at Branch No. 1, Institute 88, Gorodomlya Island	DATE DISTR.	17 June 1953
		NO. OF PAGES	41
DATE OF INFO.			
PLACE ACQUIRED			

25X1

This is UNEVALUATED Information

THE SOURCE EVALUATIONS IN THIS REPORT ARE DEFINITIVE.
THE APPRAISAL OF CONTENT IS TENTATIVE.
(FOR KEY SEE REVERSE)

25X1

G-1 ROCKET GUIDANCE DEVELOPMENT WORK AT NII-88

General Description of Work and Problems Encountered

1. Work was started by the Soviets in 1948 at NII-88 on a modification of the German A-4 (V-2) rocket. A meeting held in Moscow from 20-30 December 1948 was attended by the following German specialists: WOLFF, GROETRUPP, HOCH, ALBRING, Rudolf MUELLER, Gerd MUELLER, BLASIG, BLASS, UMPFENBACH. At this conference preliminary plans for the A-4 modification, to be designated G-1, were discussed.
2. The accuracy planned for the G-1 missile was to be 50 per cent hits within plus or minus one-thousandth of the range. Thus, for the planned range of 300 km, the required accuracy would be plus or minus 300 meters. In order to achieve this accuracy the flight path must be accurate to within plus or minus three minutes in azimuth and 0.05 degrees in elevation.
3. Work on this modification was started by the Germans when they arrived on Gorodomlya Island near Ostashkov. The following major physical changes were made. The stabilizing gyroscopes and electronics equipment were moved down below the fuel tanks

25X1

USAF, DIA, review completed.

SECRET

STATE	#x	ARMY	#x	NAVY	#x	AIR	Ev	#x	FBI		AEC		OSI	ev	x	ATIC	E	x
-------	----	------	----	------	----	-----	----	----	-----	--	-----	--	-----	----	---	------	---	---

(Note: Washington Distribution Indicated By "X"; Field Distribution By "#")

25X1

25 YEAR RE-REVIEW

302

SECRET

25X1

- 2 -

near the combustion chamber, and it was decided to use integral fuel tanks, i.e., the wall of the rocket was to be the tank itself. The antennas were to be modified as described in the paragraph on the airborne receiver and transmitter (See Page 31).

4. UMPFENBACH redesigned the rocket engine so that exhaust gases are fed from the combustion chamber to drive the turbine. During the feed-back these gases are cooled by the unburned fuel. To keep the pressure in the combustion chamber constant, it was decided to use an "Alpha Regler" (regulator). This used a pressure gauge which operated as follows: an iron membrane is placed between two pairs of coils, which are connected in a bridge circuit; and, when pressure causes the membrane to deflect, the inductance of one pair of coils is increased, and the other is decreased. Since a 500-cycle voltage is applied to the bridge, the output is a signal proportional to the deflection. This signal is applied to a magnetic amplifier whose output drives an actuator similar to the one used to actuate the rudders in the missiles. This actuator operates a butterfly valve which controls the flow of gases driving the turbine.

5. It was calculated that at combustion cut-off the acceleration of the missile would be five to ten g. Cut-off was to occur at a distance of 45 kilometers. A number of problems were also worked on in order to prevent errors from arising after combustion cut-off. Rotation of the rocket about the longitudinal axis after cut-off is of no consequence. However, since there is little air resistance the rocket may swing about its other axes, which would cause it to come into the lower atmosphere sideways or backwards. In this position the increased air pressure may cause a sudden shock which might explode the warhead. It was decided, therefore, to use a warhead which would be detached from the rest of the rocket after combustion cut-off. This could be done in one of two ways. The warhead could be set on the rest of the rocket loosely so that it would automatically separate at the end of acceleration; or the warhead could be shot off by an explosive charge. The latter plan, however, would give the warhead additional velocity and might, therefore, introduce an error. It was also proposed that velocity and range could be measured after combustion cut-off and that a command be transmitted to cause one of several different sized charges to blow off the warhead in order to compensate for any errors introduced in combustion cut-off. 25X1
this method was somewhat far-fetched and too complicated and could cause a serious error if the rocket had changed direction after cut-off; therefore, the first system, using a loose warhead, will probably be accepted. The proposed warhead was to weigh 300 kg.

6. Another problem discussed was the glowing of the warhead as it travels through denser atmosphere. It was proposed, therefore, to cover the warhead with a thin layer of wood which would carbonize, but protect the warhead. It was planned to place a solid steel point on the tip. The wood covering was to extend slightly farther back than the warhead in order to keep the center of pressure behind the center of gravity so that the warhead would fall point first.

SECRET

SECRET

-3-

25X1

7. A number of Soviets frequently came to Ostashkov to keep track of the developments there. This group usually included (a) chief engineers, directors, and other scientists from Zavod 88; (b) groups of men from the Ministry for Armaments; (c) KONOPOV, who was presumably working on similar developments in Leningrad, and several of his engineers; (d) scientists from other groups.
8. The following security measures were taken at Ostashkov. All secret papers had to be kept in a suitcase assigned to each of the more important specialists. Each paper was numbered, and a list of the numbers kept in the suitcase as a check. Every night all the suitcases had to be locked in room No. 14 [redacted] and in the morning proper identification had to be presented to obtain one's suitcase. A system of badges and passes was used to allow only authorized persons to enter the various laboratories and offices in which secret work was being performed. 25X1
25X1
9. In the fall of 1951 the work of the Guidance Group [redacted] was taken over by a Soviet group whose chief was FOMIN. After this time none of the Germans were permitted to enter the laboratories where this work was continued. 25X1
25X1
10. Flight tests were made in 1951-52 of the guidance system developed for the G-1 missile using PO-2, AN-2, and Li-2 aircraft. The equipment to be carried on the rocket was installed in the aircraft and flights were made usually heading north from Gordomlya, over Lake Seliger, up to a distance of 100 km. By flying circles around the ground station on the island it was determined that a relative velocity of 0.1 meters per second could be detected by the equipment. The PO-2 usually landed on a field on the mainland shore west of Gorodomlya, while the other aircraft had to land on a larger field located 28 km south of Ostashkov. The field was about two km square. Both fields were not airports, but merely meadows maintained enough to permit these planes to land. [redacted] no information on the maintenance schedules, repair difficulties, etc., of these planes [redacted] the maintenance was performed in Moscow. None of these planes was flown at Ostashkov in the winter. To have a plane available for a test flight it was necessary to order it one month ahead of time. Zavod 88 had three or four PO-2's, 3 Li-2's, and AN-2 assigned to it. 25X1
25X1

Evaluation of Soviet Progress

11. In the fall of 1951 a conference was held in Moscow to discuss the G-1 development. This conference was attended by FOMIN, who reported [redacted] that the G-1 was criticized, but that it was also said that it is better to have this than nothing at all. 25X1
12. [redacted] the Soviets were not entirely happy with surface-to-surface guided missiles. [redacted] this might be due to the fact that the Soviets do not have enough competent engineers to carry on such work, and that very few of them have the self-confidence to be willing to take on a responsibility of this type, since failure is not tolerated. Even FOMIN was apparently trying to be transferred to another project. 25X1
25X1

SECRET

SECRET

25X1

13. Evidence of Soviet incompetence is reflected in the firing tests made with German A-4 missiles in 1947. These missiles had been put into operating condition in Moscow and were placed on an A-4 train. This train went to Kapustin, where the firing tests were to be made. At first the firing tests were unsuccessful and Dr. HOCH was called to Kapustin to straighten the situation out. Future tests were successful, and HOCH received a bonus equivalent to two months' salary. This indicated that HOCH had helped the Soviets out of a very tight spot. At the same time [redacted] these indications of incompetence may be deliberate in order to conceal their real progress in this field. (The "A-4 train" was a special train fitted out with all the equipment necessary to transport and fire A-4 rockets. It included cars for measuring and control apparatus, Messina telemetering equipment, workshops, several sleepers used as living quarters, and conference cars. Three cattle cars, with the ends removed, were used to carry the rocket. Two of these trains went to Kapustin in September 1947, and sections of them returned to Moscow in early [redacted] Specialists who had been at Bleicherode after the war told [redacted] that they had equipped two such trains. From the train, the A-4 rocket is transferred to a "Meiler Wagen", which is a special truck designed to pick up the rocket, carry it, and set it up on end on a launching table.)
14. [redacted] a Soviet, KONOPLOV, [redacted] apparently was developing another guidance system for the A-4 rocket in Leningrad. KONOPLOV also was part of the group which visited Ostashkov at frequent intervals. [redacted] the 50-centimeter wave length which [redacted] for guidance would be seriously attenuated by the jet stream of the rocket. [redacted] KONOPLOV was working on a wave length of five to six meters and [redacted] these objections were voiced by KONOPLOV in order to find fault with his "competitors". The reason for this opinion on 50-centimeter waves may be due to the fact that on initial firing tests the A-4 used a slot antenna near the tip of the rocket which would have characteristic loops, adjacent to the surface of the antenna, but not directly back from the center of the rocket.
15. Rockets of this type should be launched at an angle of 45° instead of vertically in order to have a sufficiently simple method of control. With vertical launching, it is necessary to have the antennas a distance of 2.8 kilometers from the launcher. This means that once the stations are set up it is possible to fire missiles in only one direction. With slanted launching it is possible to have the ground equipment adjacent to the launcher and it would be easy to change the direction of firing. Slanted launching would, of course, involve some type of starting aid.
16. [redacted] it will be approximately two years before the Soviets will be able to fire a rocket using the guidance system developed [redacted]

SECRET

SECRET

25X1

Components

17. Whenever possible, electronic components, such as transformers, resonant cavities, special potentiometers, etc., were produced at Ostashkov. Vacuum tubes were obtainable in sufficient quantity.

25X1

The metal-ceramic tubes used were mostly of East German manufacture (Oberspreewerk - OSW). Soviet copies of these types frequently had leaks at the metal-ceramic seal. An attempt had been made at the factory in these cases to close the leak by painting over it with lacquer.

25X1

The boxes in which they were shipped were marked with a pentagon:  One type of tube which was available in very large quantities was a voltage regulator tube having five electrodes, the STV 280/40, 60, 80, and 150. This is an old German design and was included in the circuits developed at Ostashkov whenever a voltage regulator tube was needed. The most popular tube manual in the Soviet Union is one edited by GURFINKEL.

25X1

18. The magnetic amplifiers to be used in the rocket were units taken out of a German direct current - three-phase converter apparatus. They were designed for two DC inputs of 0.5 m.a. with a 2000-ohm winding resistance. A 4-volt, 500 cps voltage is applied, and a DC output is obtained from two bridge rectifier circuits. This output has a maximum value of 15 m.a. working into a 500-ohm load. Physically, the magnetic amplifier is 40 x 40 x 12 millimeters in size. difficulty may be encountered with these amplifiers due to voltage breakdown between windings at high altitude.

25X1

25X1

19. The small gyroscopes to be used in the rocket and in the path simulator were at first obtained from Germany. Later exact Soviet copies were delivered. These were probably made by the Institute fuer Automatik und Telemechanik. The characteristic resonant frequency of vibration of these gyros is approximately 40 cps. It was found, therefore, that the gyros could not be used to stabilize oscillation above 25 cps.

25X1

25X1

20.

some components shipped to Ostashkov being exact Soviet copies of SCR 584 components. These parts included crystal detectors, thyratrons, cathode-ray tubes for PPI and A-scopes, 10 cm. wave guide never saw any Soviet-built magnetrons, but they were being manufactured there.

25X1

25X1

Ground Transmitter

21. The ground transmitter transmits a 600 mc. signal at a power of 80 watts. This signal is produced as follows [See Page 33].
22. A crystal oscillator, generating a frequency of 12.5 mc., feeds a frequency doubler, which uses Class C operation with

SECRET

SECRET

25X1

a tank circuit tuned to 26 mc. This frequency is tripled in a similar circuit tuned to 75 mc. Subsequent stages consist of alternate amplifiers and frequency doubler stages until the frequency is up to 600 mc. The stages operating at 300 mc. use LD-12 lighthouse tubes, while the 600 mc stages use LD-9 and LD-7 metal ceramic tubes (German types, copied by the Soviets).

23. A signal is fed from the first 600 mc amplifier to the ground receiver, where it acts as local oscillator. Amplitude modulation is applied to the second 600 mc amplifier stage. Four modulation signals are applied at this point: azimuth steering command, elevation steering command, combustion cut-off command, and the pulse for range measurement. The modulation signals are mixed at the outputs of the command generators and applied directly to the cathode of the LD-9 tube.
24. In each of the LD-9 and LD-7 amplifier stages the r-f power input is applied to the cathode cavity, and the output taken from the anode cavity. See Page 34 for sketch of the construction of these cavities. Co-axial cable is used to feed the signal from the last amplifier stage to the antenna, which is a horizontal dipole in a 3-meter diameter parabolic reflector. An alternate circuit, having one less power amplifier stage, was also used successfully.
25. Initially it was planned to use a single frequency multiplier stage to multiply the crystal frequency of 12.5 mc by six, producing a 75 mc signal. However, it was found that an additional amplifier stage would have been necessary, due to too small a voltage output for such a frequency multiplier.

Ground Receiver and Velocity Measurement

26. The receiving antenna is identical to the transmitting antenna; i.e., a dipole in a 3-meter diameter parabolic reflector. The carrier frequency of the received signal is 605 mc, with 15 mc side-bands, only the lower one of which (590 mc) is of interest. (The carrier frequency actually varies with the velocity of the missile due to the Doppler effect. This will be discussed in a later paragraph.)
27. A co-axial cable is used to connect the antenna to the crystal detector. In order to match the impedance of the line (60 ohms) to that of the detector (150-300 ohms) a co-axial "transformer" is used, in which a 1/20 wave length stub is located 1/4 wave length from the detector. A 600 mc signal from the ground transmitter is used as local oscillator and applied to the co-axial line at the point at which the stub is connected. This results in intermediate frequencies of 5 and 10 mc after detection (the difference between 600, 605, and 590 mc). The output of the detector is fed to two tank circuits, resonant at 5 and 10 mc respectively. These are coupled to pre-amplifiers using 6AC7 and 6AG7 tubes 25X1
28. The circuitry from the dipole to the pre-amplifiers is all located near the antenna. The output of the pre-amplifiers are coupled to co-axial cables running to the mobile van

SECRET

SECRET

25X1

-7-

where most of the equipment is located. Here the lines are coupled to two 5-stage IF amplifiers, using 6AB7 tubes, with the automatic gain control fed back from the fifth stage to the first by means of a 6X6 dual diode. The second section of the 6X6 at the output of the 10 mc. IF amplifier is used as detector for the range measurement pulse, which is then fed to the range measuring circuits.

29. The output of the 5-mc IF amplifier is doubled in frequency by using a 6AB7 in Class C operation with a tank circuit in the plate resonant at 10 mc. The two IF signals are then applied to two grids of a 6A8 converter whose output feeds a low-pass filter which cuts off at approximately 20 kc. Thus the only remaining frequency is the one resulting from the Doppler effect, indicating velocity of the missile.
30. This Doppler frequency is mathematically derived as follows:

Frequency of ground transmitter f_0 (600 mc.)

Frequency of airborne transmitter f_B (605 mc.)

Velocity of rocket v

Velocity of electromagnetic radiation c

Frequency received by rocket: $f_0(1 - \frac{v}{c}) = f_0 - f_0 \frac{v}{c}$

Airborne Receiver IF: $f_B - f_0 + f_0 \frac{v}{c}$

IF is tripled: $3f_B - 3f_0 + 3f_0 \frac{v}{c}$

Frequency of Airborne Transmitter: f_B and side bands $f_B \pm 3IF$

but only lower side band is of interest.

Therefore: $f_B, f_B - 3f_B + 3f_0 - 3f_0 \frac{v}{c} = -2f_B + 3f_0 - 3f_0 \frac{v}{c}$

Frequency Received on ground: $f_B - f_B \frac{v}{c}, (-2f_B + 3f_0 - 3f_0 \frac{v}{c})(1 - \frac{v}{c})$

$= f_B - f_B \frac{v}{c}, -2f_B + 3f_0 - 3f_0 \frac{v}{c} + 2f_B \frac{v}{c} - 3f_0 \frac{v}{c} + 3f_0 \frac{v^2}{c^2}$

But $\frac{v^2}{c^2}$ is negligibly small.

collecting terms: $f_B - f_B \frac{v}{c}, -2f_B + 3f_0 - 6f_0 \frac{v}{c} + 2f_B \frac{v}{c}$

These are mixed with f_0 in ground receiver to form intermediate frequencies: $f_B - f_B \frac{v}{c} - f_0, f_0 + 2f_B - 3f_0 + 6f_0 \frac{v}{c} - 2f_B \frac{v}{c}$

Doubled: $= 2f_B - 2f_0 + 6f_0 \frac{v}{c} - 2f_B \frac{v}{c}$

$2f_B - 2f_0 \frac{v}{c} - 2f_0$

These two frequencies are mixed in a 6A8 converter, resulting in the difference frequency:

$[2f_B - 2f_0 + 6f_0 \frac{v}{c} - 2f_B \frac{v}{c}] - [2f_B - 2f_0 \frac{v}{c} - 2f_0] = 6f_0 \frac{v}{c}$

This, then, is the frequency which appears at the output of the low-pass filter. The signal is amplified by two stages of voltage amplification and a power amplifier which feeds the primary

SECRET

SECRET

-8-

25X1

of an audio-frequency transformer. The secondary is connected to a special frequency bridge which has two outputs See Page 35: (A) has constant phase, while (B) has a phase angle of either plus or minus 90° with respect to (A). The amplitude of (B) is zero at the frequency at which the phase changes. The 100,000-ohm potentiometer in the frequency bridge is adjusted so that this zero point occurs at the frequency corresponding to the desired missile velocity at combustion cut-off.

31. The two outputs, (A) and (B), are amplified and applied to a "gesteuerter Gleichrichter" (controlled rectifier). This is essentially a bridge rectifier circuit, which receives two sets of signals from transformer secondaries. The output is taken from the center taps of these secondaries. It will be DC voltage, with zero amplitude corresponding to the desired combustion cut-off point. The DC voltage is fed to the combustion cut-off command generator through a low-pass filter which cuts off at approximately 300 cps, to reduce ripple.

32. The ground receiver, frequency bridge, etc., were designed by Dr. MOLLWO

that velocities of 0.1 meters per second can be detected, as proved by flight tests at Ostashkov.

PREIKSCHAT has applied for a patent on a slight variation of this method to be used for highly accurate location measurement. This could be used for surveying (e.g., coastlines) with an airplane, or for air reconnaissance to pinpoint targets. The aircraft would fly over a known fixed point, and from then on its velocity, as measured by the above principle, is integrated and thus shows the exact path. Of course, two separate ground stations would be necessary if the aircraft flies anything but a straight path. To pinpoint a target the aircraft would transmit a signal when it is over the target.

Range Measurement

33. The measurement of range is accomplished by transmitting a pulse and comparing the time it takes the echo to return with the time between the echo and the next transmitted pulse.
34. The output of a variable 40 to 60 kc oscillator is fed to a pulse generator See Page 36. The rectifier used in the anode circuit of the pulse generator is an aluminum selenium rectifier and serves to damp oscillations after the pulse is formed. A 3 to 4 microsecond pulse, having a repetition rate of 40 to 60 kc, is thus produced. The 40 to 60 kc sine wave is also applied to two multivibrators which successively produce a 2:1 countdown. Their outputs are thus a 20 to 30 kc and a 10 to 15 kc square wave. These square waves and the pulse are all added together and applied to a trigger amplifier in

SECRET

SECRET

25X1

-9-

such a way that only every fourth pulse will cause the amplifier to conduct (See Page 36 7. This pulse, having a repetition rate of 10 to 15 kc., is then applied to the transmitter as modulation.

35. The pulse is also applied to a third multivibrator. The returned (echo) pulse is received by the ground receiver and fed to this same multivibrator from the 10 mc IF amplifier through a 6X6 detector. The multivibrator will be flipped one way by the transmitted pulse and back by the returned pulse. A square wave is thus obtained, with its length proportional to the range measured. This square wave is coupled from the two plates of the multivibrator tubes to the grids of two triodes whose plate circuits include large (1 to 2 microfarad) capacitors. A DC voltmeter is connected between the two plates. It indicates a voltage proportional to the difference in the periods of each of the two conditions of the multivibrator. This indication is, therefore, proportional to the range of the missile.
36. The time between transmitted pulses, at a repetition frequency of 10 to 15 kc, corresponds to a range of approximately 9 to 13 km. The voltage, V, will, therefore, start at a maximum negative value, increase linearly to maximum positive value, at the above-mentioned range, then drop sharply to the maximum negative and start over again.
37. The frequency of the 40 to 60 kc oscillator is adjusted so that the range at which the combustion cut-off is desired will correspond to zero voltage in the fifth saw-tooth cycle. Assume that the cut-off range is to be 45 km. Then the frequency of oscillation will be set to 52.4 kc so that the time between transmitted pulses (at a repetition frequency of 13.1 kc) will correspond to a range of 10 km. An operator watches the voltmeter and throws a switch at the end of the fourth saw-tooth cycle, which closes the circuit to the cut-off command generator. The voltage, V, is then added to the velocity-indicating voltage, resulting in the cut-off command being generated at the required range and velocity. this system will prove to be very poor in operation, primarily because of the noise which will accompany the echo pulse. this noise may frequently be of sufficient amplitude to trigger the multivibrator so that incorrect range readings will result. It would be better to use some type of cathode-ray tube presentation, such as an A- or J-scope, and to have an operator keeping track of the range, since an operator can distinguish between the returned pulse and noise. This circuit was essentially a development by Prof. Theodor SCHMIDT.

25X1

25X1

Direction Finding

38. For direction finding in azimuth and elevation, four antennas are used. These will be designated right upper, right lower, left upper, and left lower. The distance from the right to the left antennas is 17.5 meters; that between upper and lower, 3 meters. Each antenna is a dipole in a 3-meter diameter parabolic reflector.
39. A 66-ohm co-axial line connects the left upper antenna to the right lower, and the left lower to the right upper. A switch is connected to these lines See Page 37 schematically. The switch may be considered a two-bladed vibrating type with an operating cycle as shown.

SECRET

SECRET

25X1

- 10 -

40. If the missile is on the correct path the signal amplitudes at all four switch contacts will be the same. If the missile moves out of this path, a difference in signal strength will be observed between the corresponding pairs of antennas. Therefore, in the four-part cycle of the switch, a comparison of parts I and III will indicate deviation in azimuth, and parts II and IV deviation in elevation. The cycle is repeated 25 times per second; thus each position of the switch is maintained for 1/100 second. The switch is driven by a 25 r.p.s. motor. Sketches of the actual construction of the switch and the coaxial lines are shown on page 38.
41. From the switch the signal goes through a detector, a 5 mc amplifier, and a second detector, which are identical to the circuits used in the ground receiver. The signal after the second detector will be a 4-section square wave with each section having a period of 1/100 second. This square wave is fed through a low-pass filter having a 1000 cycle cut-off frequency to eliminate ripple without rounding off the corners of the square wave.
42. The resulting signal is amplified in a special low-frequency amplifier: one or two stages using 6AC7's and one stage using a 6F6. The amplified signal then goes through another rotating switch which is driven by the same 25 r.p.s. motor that drives the first switch See Pages 32 and 38. Each part of the switch has three positions: 1, 2 (ground), and N (no contact). The positions during the 4-part switching cycle will be as follows:

	I	II	III	IV
Switch A	1	N	2	N
Switch B	N	1	N	2

The voltage across capacitors C3 and C4 will, therefore, indicate the difference between alternate parts of the cycle, and thus the deviation of the missile in azimuth and/or elevation. These voltages can attain a maximum value of plus or minus 80 volts. They are applied to differentiating circuits to produce a signal proportional to $E + \frac{dE}{dt}$, where E is the angle of deviation of the missile from the desired path. This signal is then applied to the command generator for transmission to the missile. The reason for the $\frac{dE}{dt}$ part of the signal will be discussed in the section on rocket steering and stabilization (paragraph 60).

Command Generators

43. With respect to the combustion cut-off command, not certain of the details of this circuit and can only discuss the principles involved. The circuit was designed by Prof. Theodor SCHMIDT.
44. Two DC signals, representing the distance and velocity of the missile, are produced as discussed in previous paragraphs. These signals have zero amplitude at the required combustion cut-off values. It normally happens, however, that one of these values will be attained before the other, so that the missile would fall short of the target if the rocket engine were cut-off then.

25X1

SECRET

SECRET

25X1

- 11 -

45. For this reason the two signals are added, so that the cut-off command is produced when their sum is equal to zero. The signals have positive slopes for increase in distance and velocity, and the slopes are adjusted in such a way that when the sum of the signals is zero, regardless of the value of the individual signals, the missile will still hit the same target. The circuit is designed for a maximum deviation from the desired cut-off values of approximately plus or minus ten per cent for distance, three per cent for velocity.
46. The sum of these two signals is applied to one grid of a 6A8 pentagrid converter. The cathode of this tube is biased so that no plate current will flow until the grid potential is at least zero volts. The output of a 6 kc L-C oscillator is connected to another grid of the 6A8. Thus, when plate current is drawn, a 6 kc output signal is obtained. This, combined with the other commands, is fed to the ground transmitter as amplitude modulation. After the 6A8 has conducted for approximately one-tenth second it is cut off by a time-delay relay.
47. The time used in transmission, generation of command, etc., is predictable, and, therefore, introduces no appreciable errors. A much larger and less accurately predictable error is caused in the extinction of combustion in the rocket engine. The exact amount of fuel left in the lines between the shut-off valve and the engine, and the burning time of this fuel, cannot be accurately predicted and this, therefore, is the major error to be taken into consideration.
48. The azimuth and elevation command circuit was developed by Dr. Franz LANGE. [redacted]
49. Two identical command generators are used: one for azimuth, one for elevation. Basically the generator consists of an R-C oscillator using a 6X7 tube (similar to US 6K7 with linear characteristic). One of the resistors in the R-C circuit consists of the variable plate resistance of a 6K7 tube, whose grid potential is controlled by the azimuth (or elevation) signal from the direction finding equipment. The maximum variation of this grid bias is from cut-off to zero bias.
50. By means of the grid bias variation the frequency of the R-C oscillator is varied about a center frequency of 2.5 kc for the azimuth command generator, and 3.7 kc for elevation. The maximum frequency variation is plus or minus seven or eight per cent.
51. A reactor tube (Blindröhre) was also used in this circuit [redacted]. The frequency control in the R-C oscillator was very complicated; an L-C oscillator would have been simpler and more stable.
52. The azimuth and elevation command signals are combined in a resistance network and the combination amplified by a 6F6 power amplifier.
53. [redacted] not remember how this signal is combined with the combustion cut-off command signal and the range measurement pulse, but all these signals are jointly amplified by a 6L6 (Soviet 6B3) tube and then applied to the cathode of an LD-9 tube to modulate the carrier of the ground transmitter.

25X1

25X1

25X1

25X1

SECRET

SECRET

-12-

Airborne Receiver and Transmitter

54. The airborne receiving and transmitting antennas consisted of dipoles with reflectors. These were to be placed either inside a nonmetallic section at the bottom ends of the rocket fins, or in the area between the fins and the jet stream.
55. A 60-ohm co-axial line from the antenna leads into an impedance matching section, where a 605 mc signal, to be used as local oscillator, is also introduced. A crystal detector thus produces a 5 mc intermediate frequency, which is amplified in an IF pre-amplifier and sent on a co-axial cable to the electronic apparatus, which is to be located below the fuel tanks near the rocket combustion chamber.
56. Here the signal is amplified by an IF amplifier using 6AG5 tubes, with feedback for automatic gain control. The bandwidth of the IF amplifier is approximately 0.5 mc. The second detector is a 6X6 dual diode. The low frequency command signals are then amplified by a 6AG5 in whose plate circuit are three tank circuits. These are tuned to 2.5 for the azimuth command, 3.7 for the elevation command and 6 kc for the combustion cut-off command.
57. Each of these tank circuits is coupled to another 6AG5 amplifier whose output is fed into a discriminator circuit. This results in a positive or negative voltage which corresponds to the given command.
58. A 5 mc IF signal is taken off before the second detector and fed to a frequency tripler. This is a class C operated tube with a special plate circuit which is resonant at 15 mc, but shunts 5 mc to ground. A bandwidth of approximately 1 mc about a center frequency of 15 mc is thus passed to a 15 mc IF amplifier. Its output is fed to the transmitter circuit where it is further amplified and applied as modulation to the LD-11 transmitting tube.
59. The transmitter uses a 12.6 mc quartz crystal. This frequency is tripled to 37.8 mc and then doubled four times to attain a frequency of 605 mc. The first four stages of this multiplier use two 6J6 tubes. Succeeding stages use LD-1's working into resonant cavities. The second LD-1 puts out a 0.5 watt signal into an LD-11 amplifier cavity. This is coupled into the cathode cavity of the final stage, also an LD-11. The 15 mc modulating signal is applied to the grid of this tube, and the transmitting antenna is coupled into the anode cavity. A 7-watt signal is thus sent out to the antenna.

Rocket Steering and Stabilization

60. The outputs of the command discriminators are DC voltages, the polarities of which indicate the desired direction of the command. These voltages are applied to magnetic amplifiers, which also receive signals from the stabilizing gyroscopes of the corresponding axes. The primary AC voltage applied to the magnetic amplifier is 40 volts at 50 cps. A bridge rectifier in the secondary produces a DC voltage, the polarity of which again corresponds to the direction of command.

SECRET

SECRET

-13-

25X1

61. This DC voltage controls the position of a coil in a magnetic field. This coil is wound on an iron core and, as it moves, changes the direction of a small nozzle [See Page 39]. The direction of the spray controls the up-and-down movement of a "Steuerkolben" (control piston). This piston is on a common shaft with two smaller pistons which act as valves to open one and close the other two lines which carry the operating fluid under pressure. These lines go to the two ends of the cylinder which contains the main operating piston, whose shaft is coupled to the rudder. As pointed out previously, the guidance system of G-1 was never actually installed in a rocket. For this reason, the steering mechanisms discussed here were merely proposals, and frequently alternate systems were proposed without a final decision on which is to be used.
62. Three alternative fluids were proposed to operate the steering mechanism: alcohol, compressed air, and hydraulic oil. The disadvantage cited for alcohol is that it would tend to soak into the electrical insulation and thus destroy its insulating properties. It would be satisfactory to use alcohol for actual operation, however, since in the time of one firing of the rocket it would not have a chance to do appreciable damage. Compressed air is compressible, and therefore apt to oscillate. It would also be necessary, when using air, to use an oil-soaked felt piston ring for lubrication of the cylinder walls, and regular piston rings. Nevertheless, [redacted] compressed air is the most likely to be used. The time constant of this actuation mechanism was expected to be 10 to 20 milliseconds. 25X1
63. The transmitted steering commands correspond to the deviation angle ϵ plus its derivative $\frac{d\epsilon}{dt}$. The derivative is included in the signal to reduce the overshoot as the missile approaches and goes through the correct path.
64. Stabilizing "Markgraf Kreisel" [see Path Simulator description on Page 40] gyroscopes are to be used in each axis of the missile. The gyro itself is small so that its characteristic frequency of oscillation will be much higher than that of the guidance system of the rocket. This type of gyro was called the "rasende Wallnuss" (racing walnut). Its synchronous speed is approximately 30,000 rpm.
65. The voltage corresponding to the gyro's angle of precession is taken off a special center-tapped potentiometer made of resistance wire wound on an anodized aluminum bar. The moving contact consists of a very light pressure (low friction) platinum wire loop. The voltage taken off here is proportional to the angle γ between the path of the rocket and its longitudinal axis, plus its derivative $\frac{d\gamma}{dt}$. This signal is applied to the magnetic amplifier whose output actuates the rudders.
66. Approximately one-tenth of the transmitted $\epsilon + \frac{d\epsilon}{dt}$ command signal is applied to the "steering coil" of the gyroscope. This is necessary for the following reason: Before firing, the capacitor in the Markgraf circuit is short-circuited. At the instant of firing, this short circuit is opened so that the gyro will try to maintain the position it has at this moment. Since this position may deviate slightly from the

SECRET

SECRET

25X1

- 14 -

desired path, the ϵ signal is applied to turn the axis of the gyro towards the correct position. The derivative of ϵ is not necessary for this operation; it is included only because it is contained in the transmitted signal.

67. The "Drehmagnet" (turn magnet), which is controlled by the output of the magnetic amplifier, is copied from a design by the Askania company (German). It consists of a bar which is turned by an electromagnet, and coupled to the spray nozzle of the control piston. An inclined surface, which moves with the main operating piston, is set up to tilt the housing of the turn magnet [See Page 39] so that the main piston will not move to the end of its travel for each command signal; i. e., so that maximum rudder angle will only result from maximum command signal.
68. Four rudders are used; two in the X-axis and two in the Y-axis. They are designed in an L-shape [See Page 40] so that, as the exposed sections gradually burn off, the center of pressure will remain close to the fulcrum of the rudder. The rudders are to be made of graphite.
69. A signal from the Z axis gyro will cause the Y-axis rudders to deflect to opposite directions, so as to compensate for twisting moments of the rocket. On the original A-4, trim tabs on the fins were used to compensate for any constant twisting moment. These, however, were to be omitted on the G-1 modification.

Antenna Follow Up System

70. Six antennas are used for the G-1 guidance system, as described previously. Each antenna consists of a dipole in a 3-meter-diameter parabolic reflector. The reflectors used were made of solid sheet metal, but it was recommended that they be punched full of holes to reduce wind resistance. The maximum wind velocity at which the equipment has to operate is 15 meters per second, since the rocket cannot be launched at higher wind velocities. The antenna characteristics were such that a sector of 20° was included between zero points, and 10° between half-power points.
71. Direction finding antennas are set up in two vertical pairs 17.5 meters apart. The transmitting and receiving antennas are set up on tripods between the direction-finding antennas. All six antennas are adjusted for the correct flight direction of the missile. The angle of elevation of the antennas is controlled by a selsyn system. The selsyns, used to indicate the position of the antennas, have a speed of one revolution per 45° of antenna angle. For the direction finding antennas, two extra selsyns are used for higher accuracy. These have a speed of one revolution per 3° . The selsyns for the right direction finding antennas act as selsyn generators and thus control the positions of all the other selsyns. The error signals from the selsyns are fed to a "controlled rectifier" similar to the one used at the output of the direction finding receiver. The DC output of the rectifier is applied to a system of pistons which is very similar to the one used to actuate the rudders in the missile. It consists of a "turn magnet" which changes the position of a nozzle that is used

SECRET

SECRET

25X1

- 15 -

to push a control piston. This, in turn, is on a common shaft with a double piston which acts as a valve, controlling hydraulic lines to the main operating piston that controls the position of the antenna. A special circuit is used at the output of the controlled rectifier for the signal which controls the position of the direction finding antennas. This circuit consists of a network of resistors arranged as follows: The command signal is applied to both the right and left direction-finding antennas. At the same time, the DC voltage, corresponding to the error signal from the left antenna, is applied to both direction-finding antennas, but in opposite polarities. Thus the error between the two pairs of direction-finding antennas is reduced to a minimum.

72. Initially a similar system was to be designed by the Institute for Automatik und Telemechanik in Moscow using amplodynes to replace the hydraulic system used here.¹ However, a finished design was never obtained. [redacted] they may eventually end up using an amplidyne system. The viscosity of the oil used in the hydraulic system becomes a problem in cold weather. It was frequently necessary to add a large percentage of kerosene to keep the equipment operating.

25X1

73. The selsyns used were German types rated at 40 volts, 500 cps. They were approximately 5 centimeters long and 5 centimeters in diameter. The selsyn generators, used for the right direction finding antenna, were approximately 8 to 9 centimeters in each dimension. These were all German units produced during the war. [redacted] also [redacted] Soviet selsyns, but they were rated for 50 cps. operation and proportionately bigger. They were exact copies of U. S. selsyns. They were supplied by the institute for Steuerung (guidance), which also sent a number of amplidyne to Ostashkov.¹

25X1

25X1

25X1

74. When firing a missile, the following sequence of operations takes place: a "program" motor drives a number of cams which open and close switches, necessary for the initial operations to fire the missile; after ten seconds this motor is stopped. The rocket is fired vertically and, until its elevation angle, as seen from the antenna, is 20°, no guidance signals are transmitted. Instead, the position of the antennas is controlled by commands from the direction-finding receiver. When an elevation angle of 20° is obtained, a relay disconnects the direction-finding receiver and connects two selsyns which are driven by the program motor. At this point the program motor starts to run again. From an elevation angle of 20° to 42.5° the position of the antenna controls the missile. Any error between the antenna and the missile is transmitted as a command signal to the missile for correction. At the elevation angle of 42.5° the program motor stops, since it is desired to hold the rocket at this elevation angle until combustion cut-off. When the combustion cut-off command is transmitted, another relay is actuated and the antennas again take the command from the direction-finding receiver. This is maintained until the end of radio contact.

75. Thus, during the first fourteen seconds, i. e., until the rocket is at 20° elevation, the antennas follow the rocket. From 20° to 42.5°, a time of approximately 26 seconds, the rocket is

SECRET

SECRET

-16-

25X1

controlled by the antenna position. This continues for another twenty seconds, at which time the combustion is cut off. After this, the antennas again follow the rocket, since it is impossible to control the rocket when there is no combustion.

76. The selsyns driven by the program motor have the same speed as the two selsyns used for the direction-finding antennas.

25X1

77. The Soviet servomechanism capabilities are generally good. [redacted] have no basis for judging their servo development abilities.

Path Simulator

78. The path simulator is an analogue computer which is designed to simulate the aerodynamic properties of a rocket, as well as its characteristics in responding to commands and to the stabilizing effects of its gyros. It could be modified to be used in the analysis of ordinary aircraft as well as all types of rockets, but the unit to be discussed here was designed especially for the G-1 modification of the A-4 rocket. For this reason, many of the components are identical to the ones designed for the G-1.

79. The chief designer of the "Bahnmodell", as the path simulator was designated, was Dr. Hans HOCH. He had done work on such an instrument in Germany in 1946, and brought a primitive design with him to the USSR. By the middle of 1948 the first unit of a new design was completed, to be used in the laboratory at Ostashkov. HOCH's closest co-worker on this project was Gerd MUELLER.

80. In December 1948 and summer 1949, two more units were completed and delivered to Moscow. These early instruments were successively improved, but they still had frequent breakdowns. They used DC amplifiers which were replaced in later models by AC amplifiers [redacted]

25X1

81. In 1949 and 1950, five improved units were built. Of these, the first and second went to NII 88, and the third went to an institute in Moscow whose address is Post Office Box 906.

[redacted] this is the institute to which HOCH, TOPFER, STOLPE, et al, were sent in November 1950, and where BUSCHBECK is also located. It has been established beyond reasonable doubt, that the address of this institute is P.O. Box 908, not 906. In winter 1950-51, approximately three more units were built for a destination not known [redacted]

25X1

25X1

82. Work was done at Ostashkov on a path simulator to simulate the three axes of the rocket instead of only one. This unit was never completely finished [redacted] In principle its operation was identical to the two-axis model.

25X1

83. Before discussing details of the Bahnmodell, it would be appropriate to describe the ballistics involved. The following angles are of importance [See Page 41]:

ϵ angle between rocket and desired course
 α angle between rocket axis and actual course

SECRET

SECRET

25X1

- 17 -

ρ angle between rocket axis and rudder
 η angle between actual course and desired course

84. Assume that initially the angle E is between three and six minutes. A steering command will be transmitted to the rocket causing the rudder to be deflected. This will cause the whole rocket to turn, but it will only gradually change the direction of its flight, since there is very little air resistance. Gradually, however, the flight direction will become parallel to the rocket axis. Thus the rocket will again approach the desired course; i. e., will approach zero. The following course of events takes place:

$E + \frac{dE}{dt}$ results in steering command transmission
 $\alpha + \frac{d\alpha}{dt}$ results in rudder control from stabilizing gyro in rocket

Both together cause change in ρ

ρ causes change in α

α causes change in η

η causes change in E

85. The heart of the path simulator, as well as of the G-1 stabilization system, is the "Markgraf Kreisel", a small gyroscope in a special circuit, which operates in such a manner that the angle of precession indicates a change in external forces, but does not return to zero when the forces stop changing. Thus the indication is proportional to the force plus the differential of the force. In principle the circuit for the Markgraf Kreisel consists of a center-tapped potentiometer, a large capacitor, and a movable coil on a bar magnet core. A DC voltage is applied across the potentiometer; the movable arm is at center when the precession angle is zero. As the gyro precesses, a voltage appears between the center tap and the movable arm. This voltage is applied to the capacitor and coil in series, resulting in the necessary spring action by movement of the coil which is attached to the frame of the gyro. When the precession stops changing, the capacitor charges to the same voltage as that between the center tap and the arm of the potentiometer, so that the current in the coil becomes zero and no force exists to return the precession angle to zero. The precession angle indicator thus remains at a position which is proportional to the sum of the applied force plus the derivative of that force.

86. In the actual Bahnmodell, two turntables are used. The gyro is mounted on the upper turntable which, in turn, sits on a ball bearing on the lower turntable. The lower one is also mounted on a ball bearing. The following angles will again be of importance in this discussion:

E angle between rocket and desired course
 α angle between rocket axis and actual course
 ρ angle between rocket axis and rudder
 η angle between actual course and desired course

SECRET

SECRET

25X1

- 18 -

The angular position of the lower turntable corresponds to η . The relative angle between the two turntables thus indicates α . Steering commands and the effect of one angle on others are simulated by rotation of the respective turntable which causes the gyro to precess. The precession signal then corresponds, as explained above, to $\alpha + \frac{d\alpha}{dt}$.

87. The rotation of the turntable is accomplished by a steering coil. This is a movable coil which operates in a very uniform magnetic field. When a DC current flows through it, it moves and thus turns the turntable. The circuits used in connection with the mechanical parts are largely the same as those used in the actual missile guidance; omitting, of course, the high frequency parts used for radio transmission.
88. The gyro in the Bahnmodell acts exactly as the stabilizing gyro used for each axis of the rocket. The mass of the rocket is represented by weights placed on the turntable while electromagnets placed at the turned down edge of the turntable simulate inertia by inducing eddy currents in the turntable.
89. A "program" apparatus is used in the Bahnmodell to simulate the predetermined variables such as: variation in air density as rocket increases in altitude, reduction in weight of rocket as fuel is expended, initial changes in direction while rocket changes from vertical to desired course, etc. This program apparatus consists of a number of cams, one for each variable, rotated by a motor. The cams act on potentiometers which apply a signal to the amplifier of the corresponding steering coil.
90. Three sets of signals are applied to the magnetic amplifier which drives the upper steering coil: $\alpha + \frac{d\alpha}{dt}$, $\epsilon + \frac{d\epsilon}{dt}$ and the preset initial steering program. These are mixed by the magnetic amplifier which is the same as the magnetic amplifier used in the rocket to produce the signal for the rudder actuation system. The output of the magnetic amplifier corresponds to the rudder steering command signal. It is applied to a two-stage amplifier and a time constant circuit which simulates the time constant of the rudder actuation. The resulting signal thus corresponds to ρ , the rudder angle. This signal is fed into a pair of Soviet 6N3 tubes in push-pull, whose plate load consists of the two parts of the steering coil. The rudder angle is thus applied as a force to the axis of the upper turntable. This responds gradually, in accordance with the mass and inertia of the rocket so that the angular position of the upper turntable always corresponds to α , the angle of the rocket axis. The AC signal representing α is fed to a 2-stage amplifier whose output controls the steering coil of the lower turntable; i. e. η . The resulting AC η signal is applied to an integrating gyro, whose output is $\int \eta dt = \epsilon$. This gyro operates as follows: The η signal drives a steering coil which acts as a force on the gyro, causing it to precess. Since the precession angle is proportional to the product of the force and the time over which it acts, it will indicate the integral of η , which is the angle ϵ .
91. The ϵ signal is fed through a circuit similar to the low frequency sections of the direction-finding receiver, command generator, and the airborne command receiver. The output signal

SECRET

SECRET

25X1

- 19 -

of this is proportional to $\epsilon + \frac{d\epsilon}{dt}$. This is fed back to the magnetic amplifier whose output is applied to the upper (OC) steering coil. A small fraction (ca. 1/10) of this signal is also applied to another steering coil in order to apply a proportional force to the axis of the gyro to effect a permanent change in its direction. The reason for this is explained in the paragraph on rocket steering and stabilization.

92. Physically, the Bahnmodell is in a cabinet resembling a desk. The center section houses controls and measuring instruments (one meter to indicate each angle). The left section houses the turntables with their indicating instruments, while the electronic and magnetic amplifiers and the "coefficient cams" are located in the right section. The 3-axis path simulator was quite similar to the single-axis model, except that, of course, all equipment was tripled. Its purpose was to simulate the interaction between axes.

93. know of no other Bahnmodell developments in the USSR.

25X1

LONG RANGE GUIDED MISSILE

94. This was one of the three major projects which were developed only on paper. No experimental or laboratory work was ever done on it. The project was worked on during the year 1949. It was presented at a conference in Moscow at the end of 1949. No German attended this meeting.

95. The missile was designated R-14. It was to have a range of 3000 km., with an accuracy of fifty per cent hits within 1/1000 of the range (i.e., 3 km.). The approximate weight was 75 metric tons with a 300 kg. warhead. (not sure that this is the correct warhead weight.) After combustion cut-off, the warhead, which was cylindrical, was to separate from the rest of the missile. A cylinder was considered to be the most advantageous shape for the free flight.

25X1

96. The missile was to be in the form of a cone, approximately 25 meters tall with a base diameter of 3 meters. It was to be a two-stage rocket, with the separation occurring by means of an internal program time mechanism at an altitude of approximately 60 km. Combustion cut-off of the second stage was to occur at a distance of approximately 280 km., which was the expected maximum range of the radio control. The velocity at this point would be approximately Mach 10. The peak altitude attained during the flight was to be 100 km.

97. The guidance system for the R-14 was to be the same as the one designed for the G-1, with only minor modifications. The antennas on the rocket were to consist of a number of dipoles mounted on four pieces of pipe which acted as co-axial lead-in. These pipes were in the form of a 90-degree arc, mounted in two concentric pairs on opposite sides of the rocket engine exhaust. This arrangement was mounted on the base of each stage of the rocket.

98. The power plant for this rocket was to include a 60-atmosphere engine for the first stage, and a 15-atmosphere engine (with a long high-altitude nozzle) for the second stage. Earlier plans had called for four A-4 engines (15-atmosphere) to be used for the first stage, but this was dropped in favor of the

SECRET

SECRET

25X1

- 20 -

single high-pressure unit. It was also debated at one time to use a bundle of five complete A-4 rockets. Four of these would fall away after the initial stage, and the fifth would continue on to the target. The main difficulty expected with these multiple engine systems, is that normally every tenth engine misfires; therefore, in a five-engine system, every other launching would be a failure.

99. The steering was to be accomplished by one of two systems: (a) to use small jet nozzles at various angles, driven by the compressed gas output of the turbine; (b) to mount the rocket engine in a ball and socket joint, or, on gimbals, and steer the whole rocket by changing the direction of the thrust. For the second system, small jet nozzles would still be necessary to prevent rotation about the rocket's longitudinal axis. The steering actuation system was to be the same in principle as the one designed for the G-1. The capacity of the system would, of course, have to be somewhat larger.
100. The rocket was to use integral fuel tanks for both stages. It was never decided whether to put the second stage engine inside the upper first stage fuel tank, or whether free space should be left between them. Since the electronic and gyroscopic apparatus was to be located around the top of the second stage engine, it would be necessary to seal it if it is to be immersed in fuel.
101. At an altitude of approximately 10 km., a ring was to be shot off from around the base of the first stage. This acted only to keep the center of gravity low at the start. A problem which was never finally solved was the question of how to ignite the second stage engine. The first stage was to be ignited by small rocket twirlers placed in the combustion chamber of the engine.
102. One question was brought up and never settled because no experimental work was done on this project. This was the question of what happens to the 50-cm. waves in the extremely high altitude through which the missile is to be controlled. At these altitudes the flight path will more closely approximate an ellipse than a parabola.
103. In connection with this project, GROETTRUP developed plans for an underground launching site for the R-14, as well as for the G-1. The plan was developed further to include an entire subterranean assembly plant designed so that final assembly would take place right at the launching site, which would be a vertical shaft, 5 to 6 meters in diameter and about 30 meters deep. A large network of tunnels connecting to this shaft were planned for the storage of parts and the sub-assemblies. It was also planned to have the ground station for the guidance system on a circle of tracks having a radius of 25 to 30 km., so that the missile could be fired in any direction. While the idea for this underground factory and launching station was GROETTRUP's, JAFFKE and members of his group carried out the design and made the drawings for it.

SECRET

SECRET

-21-

25X1

SUPERSONIC PILOTLESS AIRPLANE

104. This project, designated R-15, was also worked on during the year 1949. It was another one of the projects which were carried out only on paper with no experimental work being done at all.
105. The airplane was designed to be approximately 15 meters long with a wing span of 5 meters. [redacted] not certain of the form of the wings. The span of the horizontal stabilizers was to be 1 1/2 to 2 meters; they were triangular in shape. Steering was to be accomplished by the use of ailerons, with no rudder. Elevators were attached to the horizontal stabilizers. The fuselage was to consist of two parts, both approximately 60 centimeters in diameter. [See Page 41.] The forward part was to be lower than the aft part. Fuel was to be contained in both parts, while the warhead, electronics, and gyroscopic equipment were to be housed in the lower forward section. 25X1
106. An A-4 rocket mounted directly behind the lower portion of the plane was to be used as a starting aid to launch the missile vertically. The engine for the plane operated on the principle that at supersonic speeds the incoming air would be compressed as the shock wave is formed. At the point of maximum compression, fuel is added and ignited in a number of combustion chambers arranged in a circle. The fuel is pumped into the combustion chambers by a gasoline engine.
107. The range of the rocket was to be 6000 kilometers, and it was to fly at an altitude of 20 to 30 kilometers. When the starting rocket is cut off the plane would be flying at a velocity of approximately Mach 2. This occurs at a range of 12 to 15 kilometers. The warhead was to have a weight of 300 kilograms.
108. Various schemes were discussed for guiding this airplane; one was to use a gyroscopic horizon, which involved a gyroscope acting as a pendulum having a period of 86 meters, and thus always pointing to the center of the earth as a reference. Another scheme was the use of an optical horizon; this, however, would involve serious inaccuracies. These two schemes were discarded as being too complicated to obtain the required accuracy. The system which was finally proposed was a hyperbolic navigation system. Oswald SCHMIDT had done work on wave propagation around the earth at frequencies of 10 to 30 megacycles. He had discovered that accuracies within five kilometers were obtainable for transmission around the earth. The optimum time for the transmission of these waves was at twilight when the ionosphere is bent down and will guide the waves around the earth. It was proposed to use a system employing these frequencies to be transmitted by a keying transmitter and two transmitters for producing the navigational hyperbolas. A third transmitter would be used for determining the range of the plane, and for transmitting a drop command signal. An over-all accuracy obtainable with this system would be 20 to 30 kilometers, on the basis of SCHMIDT's measurements. It was planned to use pulse

SECRET

SECRET

25X1

- 22 -

transmission, as this would be more difficult to jam.

109. [] consider transmission at this frequency extremely important, and recommend that the United States carry on experiments at these frequencies for long-range transmission, if such work has not already been done. [] The Soviets expressed great interest in this system and asked for more detailed reports after the main report on the R-15 had been turned over to them. [] an effort be made by the United States to monitor signals in those frequencies. 25X1

110. It was proposed to use transmitters having an output power of 10 to 20 megawatts, with 10 microsecond pulses, at a pulse repetition frequency between 10 and 50 pulses per second. The rise time of these pulses was to be one microsecond. By delaying the transmission of the pulses of the second transmitter in accordance with a given code, it would be possible to cause the plane to fly in curves in order to hide its target. It would be also possible to use additional transmissions of pulses at various adjacent frequencies in order to confuse the enemy's jamming efforts. The airborne equipment was to consist of two receivers, one for each frequency of the two navigational transmitters. Thus, the time of each transmission is compared and commands are applied to the ailerons to steer the plane along the correct path. Gyroscopes are used to keep the plane horizontal and going straight ahead. The velocity and altitude of the plane are preset so that the final falling pattern may be calculated. At the time of the drop command, the wings and possibly all other parts of the plane could be shot off and the warhead alone would fall toward the target.

111. It was estimated that the temperature at the surface of the plane would be approximately 150° C. Therefore, it would be necessary to use a fuel that could stand this temperature. The electronics apparatus was to be cooled by insulation from the outer surface, and by water which would steam at approximately 40 degrees centigrade due to the low pressure at which the plane flies. It was planned to use two wire antennas, one wave length long, attached to the top and bottom of the vertical stabilizer and flying behind the airplane.

112. The completed project was presented to the Soviets at a meeting around Christmas 1949. This meeting was not attended by any Germans. Early in 1950 the more detailed report on radio navigation was completed.

ANTI-AIRCRAFT ROCKET

113. During the early part of 1950 the group at Ostashkov was given a project to design an antiaircraft rocket, to be designated R-10. This project was to be worked out only on paper; therefore no experimental work was done on it at Ostashkov, and all design work was in the form of proposals.
114. The rocket to be used for this project was almost identical to the German Wasserfall. The only change from this German rocket was that it was to have two wings instead of four. This change was debated by the Germans at great length. [] steering by remote guidance would be far simpler if four wings were used. With only two wings, it will 25X1
25X1

SECRET

SECRET

25X1

-23-

be necessary for the rocket to make 90° turn about its longitudinal axis in order to obey commands which first require a change in the Y - axis, and then in the X - axis. However, some of the other Germans, principally HOCH, advocated the use of only two wings; this plan was finally adopted.

115. A number of different guidance principles were discussed, the first and simplest was one designated "Hund" (dog). This is essentially a system in which the missile follows the target. It results in a large radius of curvature of the flight path at the beginning of the flight and a very short radius just before the intercept is made. The second principle discussed was called "Schielender Hund" (cross-eyed dog). In this system the target is illuminated by ground radar and/or a homing instrument is installed in the missile in such a way that a constant angle is kept between the flight path of the missile and the target. The missile is fired towards the initially-calculated point of intercept, and by maintaining this constant angle the intercept would be made. Another principle is that of a target-covering type of guidance which is probably the simplest ground-controlled flight and involves the use of one radar which locates the target and on whose beam the missile will fly. [redacted] advocated this system to be used with a large number of smaller rockets, 25X1 which must be fired directly into the beam of the radar rather than launched vertically.
116. The system decided on was called "Hund auf der Kugel" (dog on the sphere). The reason for this designation is that if the flight path of the rocket and the target were to be projected onto a sphere whose center was at the launching site, then a curve similar to the "Hund" flight path would be obtained. In actual flight, however, the path of the missile has a short radius of curvature at the beginning and a long one at the end of its flight. This is desirable for accurate interception.
117. The guidance system for this rocket was to involve the use of two type SCR 584 radar units. One of these was to act as target locator while the other followed the missile and would give commands to the missile until it intercepted the target. The radar equipment was to be modified in such a way that the antenna reflector would be mounted on gimbals instead of the suspension used on the original type, which permits movement only in polar coordinates. This would simplify movement of the reflector through the vertical position.
118. Another small modification to be used in the command unit was an attenuation in the transmitter wave guide to reduce the output power while the missile is so close that its detectors might be burned out by the high energy of the radiation. This attenuation was to be accomplished by inserting a section of carbon wall into the wave guide. This section would be automatically shortened during the flight of the missile by sliding a metallic section inside the carbon wall.
119. In order to achieve the flight path described above, a computer was designed to cause the command unit to follow the locator. This computer was developed by Dr. MOLLWO and Werner MUELLER. It involved a fairly complicated system of selsyns. [redacted] 25X1
[redacted] In principle it operates

25X1

SECRET

SECRET

25X1

- 24 -

as follows: Selsyn generators in the locator indicate the angles of position in the "X" and "Y" axes. The signals from these selsyns are compared with similar signals from the command unit. The distance between the target and the missile is obtained by similar means. A voltage which is a function of the difference in angle as well as of the ratio of target distance to missile distance is applied to a servomotor which drives the command antenna. By this means the beam intersecting the missile will always follow the beam intersecting the target but the difference between them will be reduced as the target approaches the missile. It would be necessary to use a homing system for the final path, and a proximity fuse, but these items were not a part of the project. The proximity fuse would possibly fire at a distance of 30 meters from the target.

120. The accuracy of the SCR 584 is plus or minus five minutes. The maximum accuracy obtainable in the selsyn system between the two radars would be plus or minus ten minutes, while the error in the rocket could add up to another ten minutes. At a 30 kilometer range, all of these errors would total approximately 300 meters. An error of this magnitude would involve a very complicated homing system to insure interception. The missile itself was to have two antennas arranged perpendicular to each other. The rocket receiver would use a crystal detector for each antenna, to be followed by a low frequency amplifier stage. The purpose of having two such antennas is to indicate rotation of the missile about its longitudinal axis.
121. Three rudders were to be used with the two-winged missile. This makes it possible to keep the rudders out of the turbulent stream behind the two wings. All three rudders were to be used for alignment about the longitudinal axis. Two of them were to react to steering commands and to commands from the gyro stabilization equipment. It was planned to use gyro stabilization in each axis, but a proposal was also included in the final report to use instead an acceleration indicator which would react to vibrations and other accelerations. To actuate the rudders, it was planned to use a system similar to the one designed for the G-1, using compressed air. Spherical compressed air containers were also to be used at 100-atmosphere pressure to feed fuel into the engine.
122. [redacted] the target-covering principle for anti-aircraft rockets, using a large number of rockets, at the original project meeting in 1950, the Soviets were very obvious about not discussing this project and passed over it quickly. [redacted] this may have been for security reasons, if the Soviets were already working on such a project. 25X1
123. Several times the Soviets suggested that the Germans develop an anti-aircraft rocket to shoot down enemy rockets. The Germans, however, consistently turned them down on this idea, claiming that it was an impossibility. 25X1
124. [redacted] the effective range of the Wasserfall rocket would be 30 kilometers, and that the weight of the warhead 25X1

SECRET

SECRET

25X1

-25-

was to be approximately 500 kilograms.

TEST STANDS

25X1

125.

This was the test stand on Gorodomlya Island. It consisted of the test stand itself on the edge of a swamp with a controller bunker adjacent to it. In the bunkers were located all the necessary controls and test instruments. Below it was a pump for water cooling of the stand. The controller could watch the combustion chamber through a small window built into the concrete wall.

126.

The test stand was used primarily for experiments on cooling exhaust gases from 2500 to 500 degrees C so that they could be used to drive the turbine. Fuel and alcohol were injected into the jet stream for cooling. The fuel to be used in the experiments was stored near the bunker. Across the road from the test stand there was a small building in which liquid oxygen was produced. The process used was that of the Lind liquefaction plant. The oxygen produced by this method was 80 to 90 per cent pure. Some of the oxygen produced here was also used for welding purposes on the island, and some was sent to neighboring towns for similar purposes.

127.

A short distance from the test stand, adjacent to the main north-south road, another small building housed offices and storage of material for the test stand. The whole area around these buildings was fenced in, and after 1950 only authorized persons were admitted,

128.

there was a test stand located next to the air-field at Factory 88 for testing Wasserfall missiles. frequently heard this test stand in operation, but never saw it.

25X1

25X1

129.

In 1947, JAFFKE surveyed an area near Zagorsk (56108N -3807E) on a steep bank of a river. According to JAFFKE, a test stand was to be installed at this location, and he and others in his group made the construction drawings for such a stand; however, he never saw the actual construction. BUGAYEV, who worked in Moscow, was reportedly living in Zagorsk in the spring of 1950 after he had joined the rocket engine group. assume, therefore, that the test stand was built at this location.

25X1

130.

there were several large test stands at Kapustin (4834N - 4543E). These were designed for firing of A-4 missiles. sent a large amount of pressure-measuring equipment to Kapustin this is where experiments were made with feed back of combustion gases to drive the turbine. never saw the test stands there and no Germans were there after the first trials in 1947. At that time HOCH, MAGNUS, and Werner MUELLER were at Kapustin, among others.

25X1

25X1

MISCELLANEOUS TEST EQUIPMENT DEVELOPMENTS

131.

The following items of equipment were designed by various engineers at Ostashkov, partly to be used for their experi-

SECRET

SECRET

-26-

25X1

ments there, and partly to fulfill orders by agencies in Moscow, principally NII 88.

25X1

Sine Wave Generator

132. Two of these units were built in 1948 and 1949 on orders of NII 88; they were delivered in the spring of 1949. The generator was to be designed for frequencies from 0.01 to 50 cycles per second. The sine wave generated had to be a perfect sine wave without any discontinuity so that the second derivative of the wave would still be a sinusoidal. An R-C generator was used to produce such a wave. Automatic gain control was not used as the AGC time constant is too fast for such low frequencies. The output of this generator was 30 - 40 milliamperes at 80 - 100 volts. In 1951 - 1952, two more such generators were built but these used a goniometer instead of the R-C generator. This involved the use of two coils, one turning inside the other. A 100 kc. voltage was applied to the stator coil, inducing in the rotor a voltage corresponding to its angular position. This voltage was rectified in a bridge rectifier whose output frequency would thus correspond to the speed of rotation of the rotor. At very low frequencies, problems were encountered due to mechanical play between the motor and the rotor coil. The bridge rectifier feeds a push-pull amplifier using the Soviet equivalent of 6L6 tubes; the rectifier used two 6X6 tubes. These generators were designed and built [redacted] and [redacted] they were to be used for testing rocket steering devices.

25X1

Oscilloscope

133. A large oscilloscope incorporating eight separate cathode-ray tubes was built for use at Ostashkov. In fall 1951, construction was started on a similar unit for NII 88 [redacted]. The oscilloscope was designed so that a movie camera could be mounted on it to take continuous pictures of the eight cathode-ray tubes. For this purpose no horizontal sweep would be used; instead, a spot would be deflected vertically in accordance with the value to be presented. The cathode-ray tubes used were German types LB-1 and LB-8.
134. One of the tubes presented time marks at intervals of 1, 1/10, and 1/500 second. These were produced by counting down from a 500-cycle crystal generator. Another one of the scopes presented the Doppler frequency resulting from velocity measurements in a special way so that it may be accurately determined. The Doppler frequency was counted down by four multivibrators to produce a ratio of 16 to 1. The outputs of the multivibrators were combined to produce saw-tooth waves having a frequency 1/16 of the Doppler frequency, and having 16 steps in each saw-tooth. By comparing the steps with the time marks, it would be possible to determine the exact Doppler frequency very accurately. The other six scopes were used to present various other values to be measured during the flight of a missile. The oscilloscope, which was to be built for NII 88, was not to include the special scope for measuring the Doppler frequency.

25X1

SECRET

SECRET

25X1

- 27 -

135. 35-millimeter film was used at a speed of 10 centimeters per second. The camera used was a normal news-reporter-type movie camera made in the USSR since the war. It had three lenses which were interchangeable. The lens used for the oscilloscope was a wide-angle lens. The distance from the lens to the face of the cathode-ray tube was one meter. Films, which could be handled up to 40 meters long, had to be threaded into the camera. A special attachment was designed to hold 150 meters of film. Originally, panchromatic film was used, but later a Soviet-made x-ray film, sensitive to the light of the cathode-ray tube screen, was substituted.

Standard Frequency Generator

136. This was designed by Dr. MOLLWO. It was quite similar to a frequency generator manufactured by General Electric or General Radio Company. The frequency of this generator was accurate to one part in 10^7 , which is the equivalent of 1/100 second per day. A 100 kc crystal housed in a thermostatically-controlled copper cylinder produced the reference frequency. Frequency dividers are used to reduce this frequency to 50 cycles and this signal drives a synchronous clock. The clock is compared with a time signal received from a radio station. The signals from the clock and from the radio receiver are compared on a cathode-ray tube and the error of the clock is thus very accurately determined. The crystal frequencies also multiplied to increase the range of the generator up to 100 megacycles.

25X1

Test Equipment for Determining Antenna Characteristics

137. This equipment was designed by me between December 1951 and April 1952. It consisted of a 15-inch diameter turntable, driven by a motor, for mounting a transmitting or receiving antenna. If a receiving antenna is to be tested, the received signal is detected in the equipment, rectified, and applied to a PPI or A scope. The sweep of the scopes are synchronized with the rotation of the turntable, and thus the antenna pattern is presented on the scope. If a transmitting antenna is to be tested, another receiving antenna must be used at a remote point. A line feeds the signal from this point to the receiver in this equipment. The turntable was designed to accommodate antennas and mounts weighing up to 20 kilograms. At one time the Soviets asked about building a much bigger equipment similar to this [redacted] that it might be intended for mounting entire rockets. This project, however, was not worked on.

25X1

Sweep Frequency Generator

138. This equipment was designed by Dr. LANGE between fall 1951 and April 1952 for NII 88. It was designed to sweep the frequencies from 27 to 33 megacycles. This was accomplished by the use of a rotating capacitor turning at the rate of 25 rps. A saw-tooth voltage is produced simultaneously to produce the sweep voltage for an oscilloscope, so that the pattern from 27 to 33 megacycles can be presented on a cathode-ray tube. [redacted] this equipment was to be used for tuning IF amplifiers.

25X1

SECRET

SECRET

-28-

25X1

Standard Signal Generator

139. This equipment was also designed by Dr. LANGE between fall 1951 and April 1952. A master L-C generator was used to produce a signal continuously variable from 16 to 35 megacycles. The signal is amplified and may be amplitude modulated by a pulse. Multiplier circuits are included in the amplifier stage so that a continuously variable output can be obtained from 16 to 70 megacycles. Tuning is accomplished by the range switch and tuning condensers.

Frequency Meter

140. This unit was designed by RANGS, who worked in the laboratory headed by SCHUETZ in fall 1951. The meter was designed to measure frequencies from 0.01 to 50 cycles per second. The measurement was accomplished by the discharge of a capacitor through a rectifier and a meter. For the frequencies from 0.01 to 3 or 4 cps., the frequency would be measured by counting the swings of the needle on the meter against a stop watch. Above that frequency the steady meter reading indicates the frequency to be measured.

Vibration Tables

141. These were designed only on paper by the drafting section under Sector 5. The basic calculations were made by TOEBE. The table was designed to vibrate on three axes. It was necessary first to design a support for the table having a high characteristic resonance. Three pairs of eccentric masses were used to produce the vibration in the three axes. The way in which the masses in each pair compensate each other determines the direction of vibration resulting from that pair. Vibrations between 10 and 50 cps. were to be obtainable with an amplitude up to five millimeters in each axis. The table was designed for testing apparatus weighing between five and ten kilograms. The table was 15 inches in diameter. The eccentric weights are driven by a motor through a long thin shaft made of steel so that the motor does not feel the vibrations. The motor speed is controllable for varying the frequency of the vibrations.

25X1

Apparatus for Balancing Gyroscopes

142. This apparatus was designed by RANGS in 1949 and 1950 for NII 88. The gyroscope to be tested is mounted on two leaf springs which are alternately held rigid. The loose spring has a magnet attached to it to induce current in a coil as it moves. This current is applied to an oscilloscope. A black spot is painted on the gyroscope and seen by a photocell as the gyroscope rotates. Output of the photocell is a "pip" which is also applied to the oscilloscope. It is thus possible to note on the oscilloscope which part of the gyroscope causes the eccentricity. Holes are drilled into the gyro to compensate for this eccentricity.

Pressure Gauges

143. These were designed for use at Ostashkov as well as on orders from NII 88 and Kapustin. They were primarily

SECRET

SECRET
-29-

25X1

designed by COERMANN and SCHOLZ. The gauge consists of a membrane made of sheet steel. When pressure is applied the membrane will deflect a maximum of approximately 0.005 millimeters. The membrane is mounted in an induction bridge. Two inductors are located on each side of the membrane, and the bridge is balanced at zero pressure. When pressure is applied, the inductance of two of the coils is increased while that of the other two coils is reduced. A signal is thus obtained from the bridge. These pressure gauges are designed to measure either direct pressures or relative pressures.

Scales for Wind Tunnel

144. This equipment was designed by COERMANN in the fall of 1950 for the wind tunnel built at Ostashkov. The scale operates to measure the forces in three axes exerted on a test body in the wind tunnel. The force is measured by twisting a specially machined piece of metal against a counterweight. The advantage of this method is that no friction is involved. The units are calibrated by adding a lever with weights to exert forces similar to those which occur in the experiments. Moments of forces applied to the test body are measured by determining the difference of the forces indicated at both sides of the wind tunnel. One of the major problems incurred in the design of this equipment was the sealing of all of the instruments, as the turbulence during the experiment would seriously affect the readings taken.

Scale for Water Canal

145. These instruments were designed by ARNOLD for use at Ostashkov. In the water canal the measurement of forces is made in only one axis. The arm holding the body in the water is held in position against a counterweight so that a scale can be read to indicate the forces on the body. In the water canal the depth of the water at any point corresponds to the air pressure in a wind tunnel. The test body may be marked in millimeters and pictures taken of the water running along it to obtain a record of the corresponding pressure. Similarly, the turbulence of the water may be recorded by putting colored drops in the water and photographing it. FRIESER was in charge of the water canal at Ostashkov. He made the calculations for equivalent pressures and test bodies at reduced scales. Measurements in the water canal were generally made by FEIKENMEYER and SLOVIV.

25X1

Test Line for Measuring Line Impedance

146. This equipment was designed by SCHMIDT between fall 1951 and spring 1952 on orders of NII 88. It was to be designed for a wave length of six meters, and this indicates that the Soviets are still interested in six-meter wave length work for rocket guidance. The equipment was delivered to the same person as the apparatus for measuring antenna characteristics. The equipment included

25X1

SECRET

SECRET

25X1

- 30 -

a frequency generator for wave lengths from two to seven meters. [redacted] The test line was approximately four meters long. A variable impedance ratio transformer was used to match the impedance of the test line to other lines.

25X1

Acceleration Measuring Apparatus

147. This apparatus was ordered by NII 88 in 1949 and 1950. It was primarily designed by COERMANN [redacted] the high frequency design, [redacted] may be used with Messina telemetering equipment. The purpose of these instruments was to measure acceleration and vibration of test rockets. Basically, the instrument is very similar to the pressure gauges described above. The membrane must have a mass whose own characteristic resonant frequency lies above the frequency of any vibrations which are to be measured. Due to the inertia of the membrane, acceleration and vibration are indicated by the output of the induction bridge. The output signal of the induction bridge was between 0.1 and 0.5 volts at 500 cycles. This signal was transformed up to 0.5 to 2.5 volts, rectified, and applied as modulation to the telemetering equipment.

25X1

25X1

Normal Frequency Generator

148. This generator was designed to produce an accurate frequency signal for calibrating frequency bridges used in the measurement of missile velocity. The apparatus was developed for NII 88 [redacted] in the fall of 1950. An L-C generator was used to generate the signal. To obtain high Q and sharp tuning, a high gain tube was used and only a small fraction of the signal fed back from the anode through a large resistance. The frequency was tunable by means of a 1000 mmf tuning capacitor. The frequency range was from 400 to 500 cps. The output signal of the generator was applied to a cathode-ray oscilloscope. Pulses from a crystal oscillator are also applied to the oscilloscope. These pulses are produced by count-down multivibrators and are obtained at pulse repetition frequencies of 100, 50, 10, 1, and 0.1 cps. By successive selection of the pulses, it is possible to tune the L-C generator to the desired frequency to an accuracy within one-twentieth cycle. This signal is then applied to the frequency bridge to be calibrated. This bridge is tuned to give a null indication at the selected frequency.

25X1

Colloidal Mill

149. This was a unit to be used presumably for grinding metals to be used in colloidal suspensions. [redacted] it was designed at Ostashkov in 1951. [redacted] the colloidal suspension might be used to increase the weight of fuel burned in rocket engines and thus increase the thrust.

25X1

1 [redacted] Comment. The correct title of this institute has not been determined.

25X1

SECRET

SECRET

25X1

- 31 -

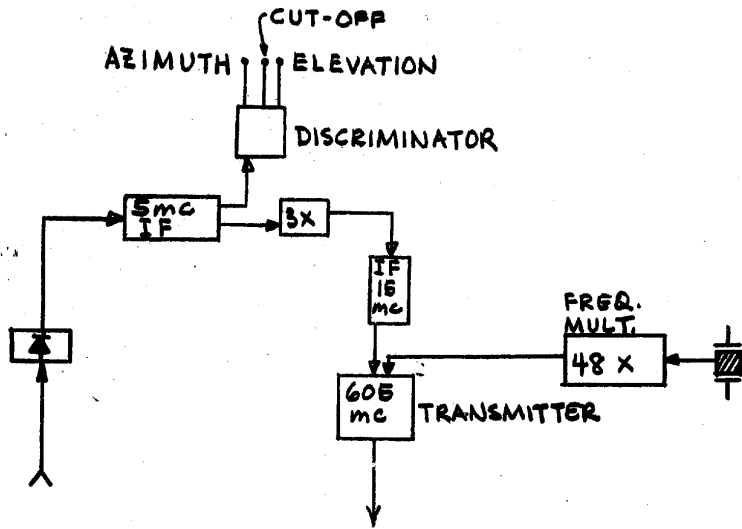

AIRBORNE

GROUND STATION

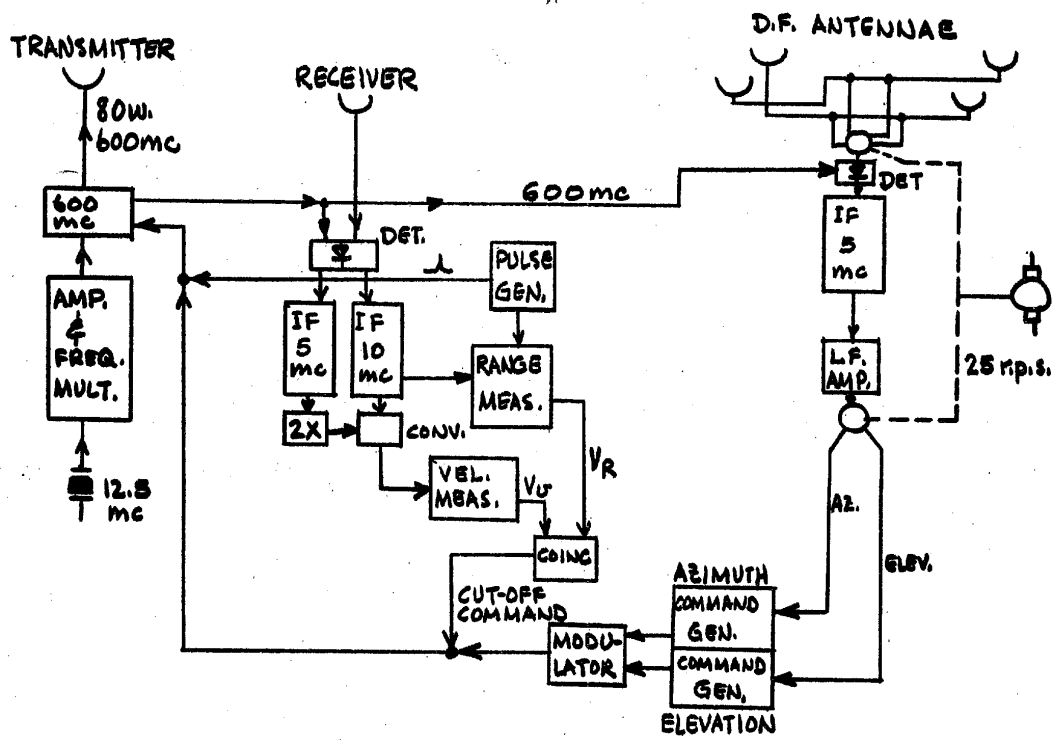

BLOCK DIAGRAM of G-1 GUIDANCE EQUIPMENT

SECRET

25X1

-SECRET-



25X1

- 32 -

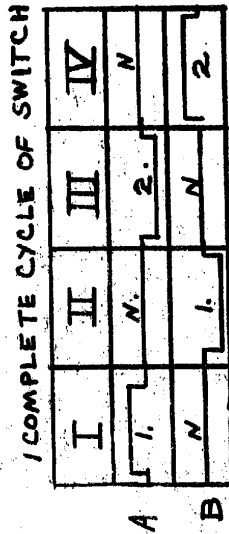
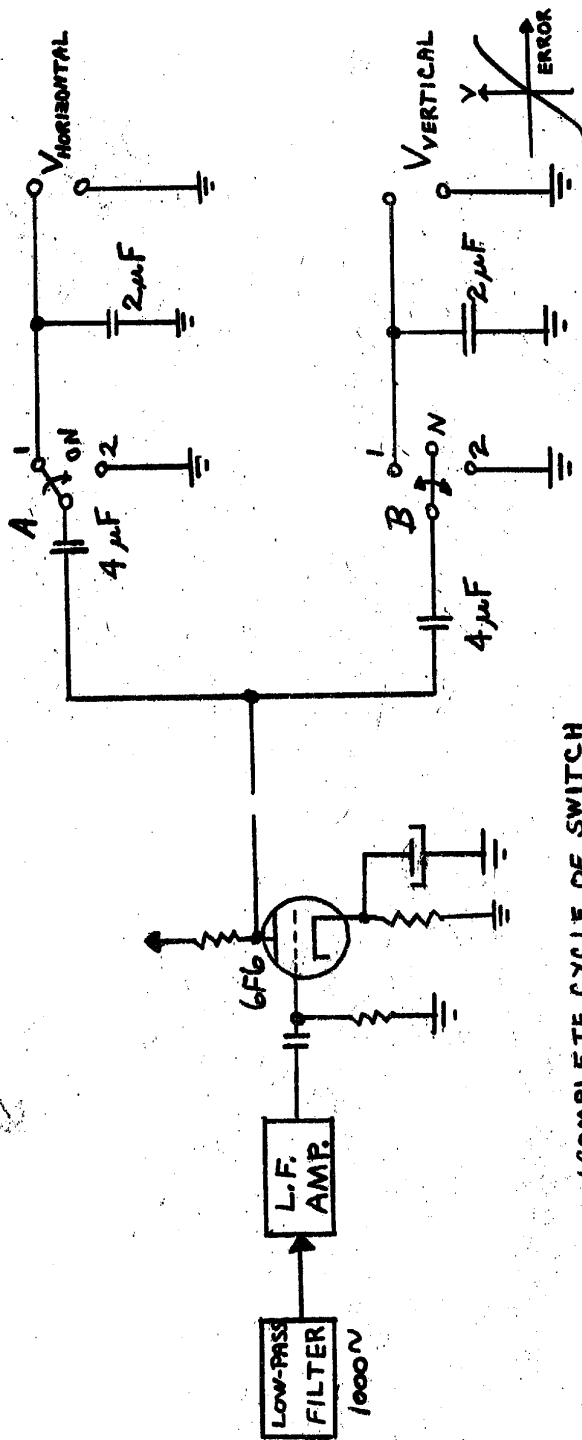

CIRCUIT DIAGRAM of SECOND SWITCH in DIRECTION FINDING CIRCUIT

-SECRET-

SECRET

- 33 -



25X1

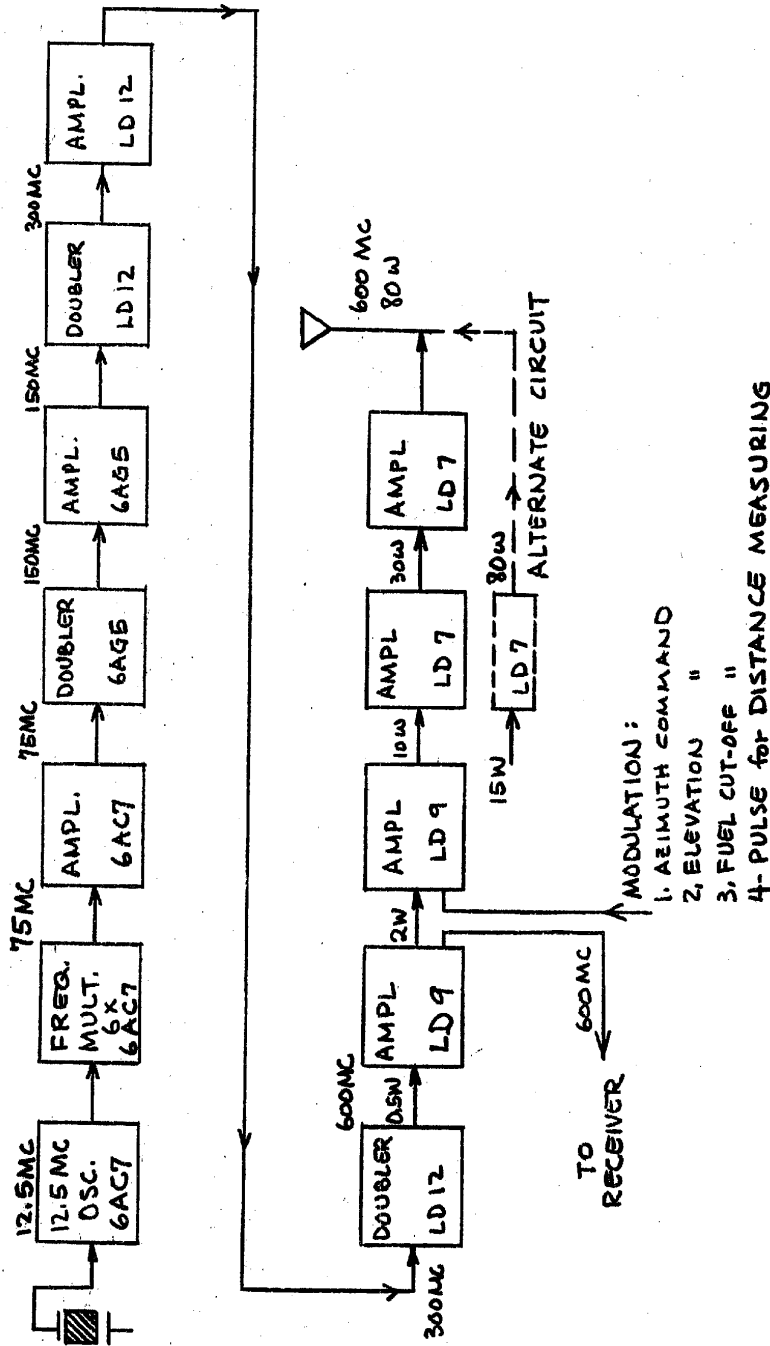

BLOCK DIAGRAM of GROUND TRANSMITTER

SECRET

-SECRET-



25X1

- 34 -

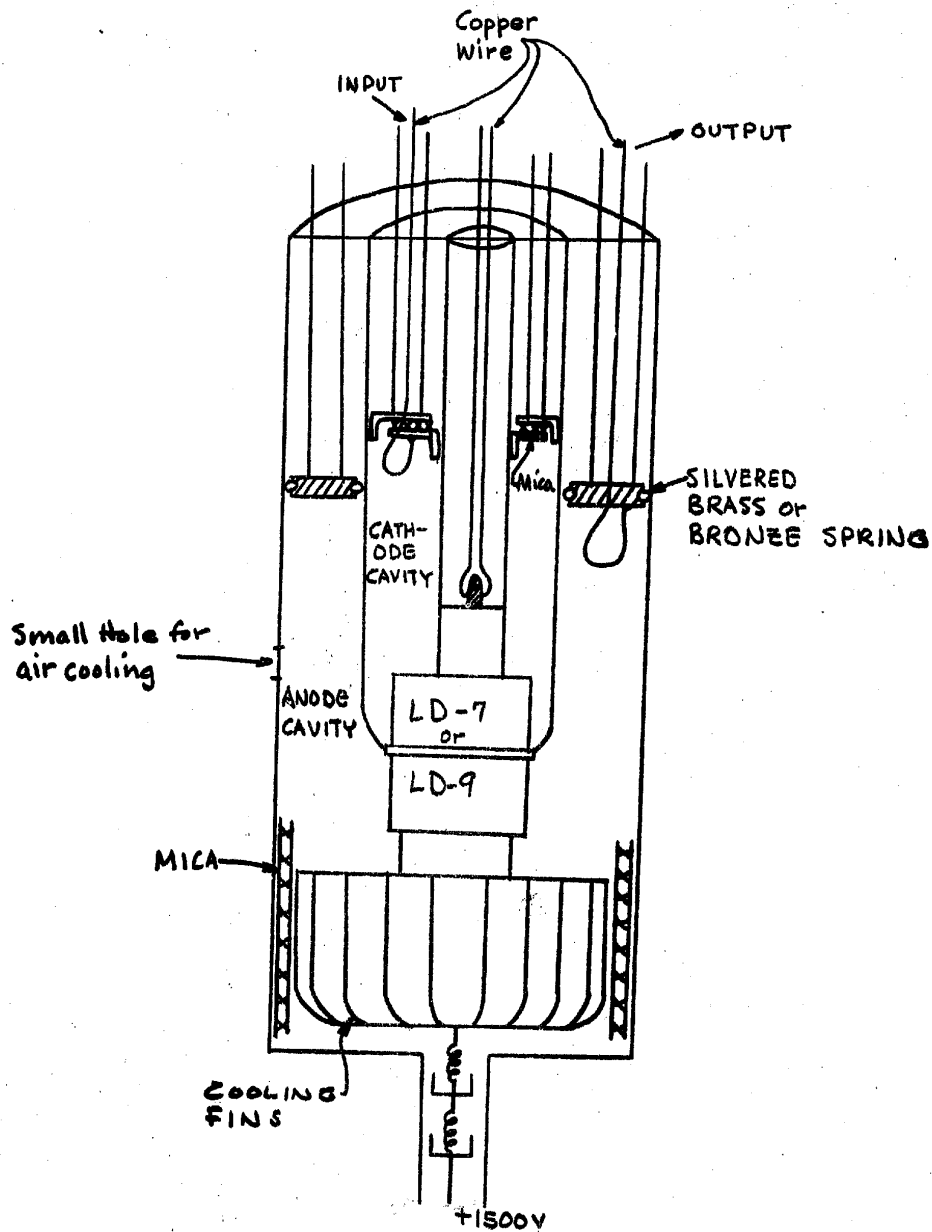

SKETCH of CAVITY DESIGNED for GROUNDED GRID METAL-CERAMIC TUBE USED IN GROUND TRANSMITTER

-SECRET-

- SECRET -
- 35 -

25X1

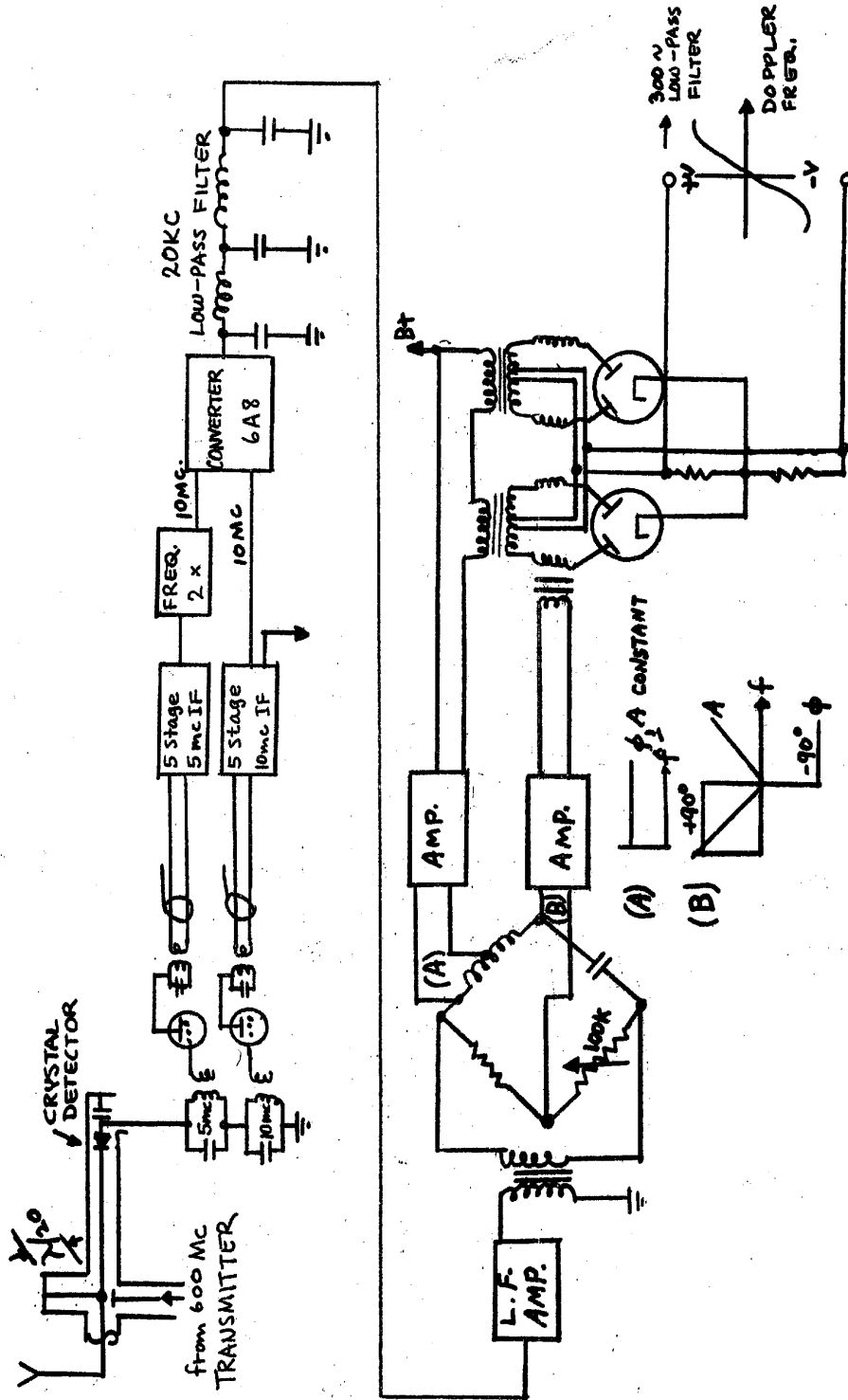

RECEIVER CIRCUITS & DOPPLER FREQUENCY MEASURING CIRCUIT

SECRET

SECRET

25X1

- 36 -

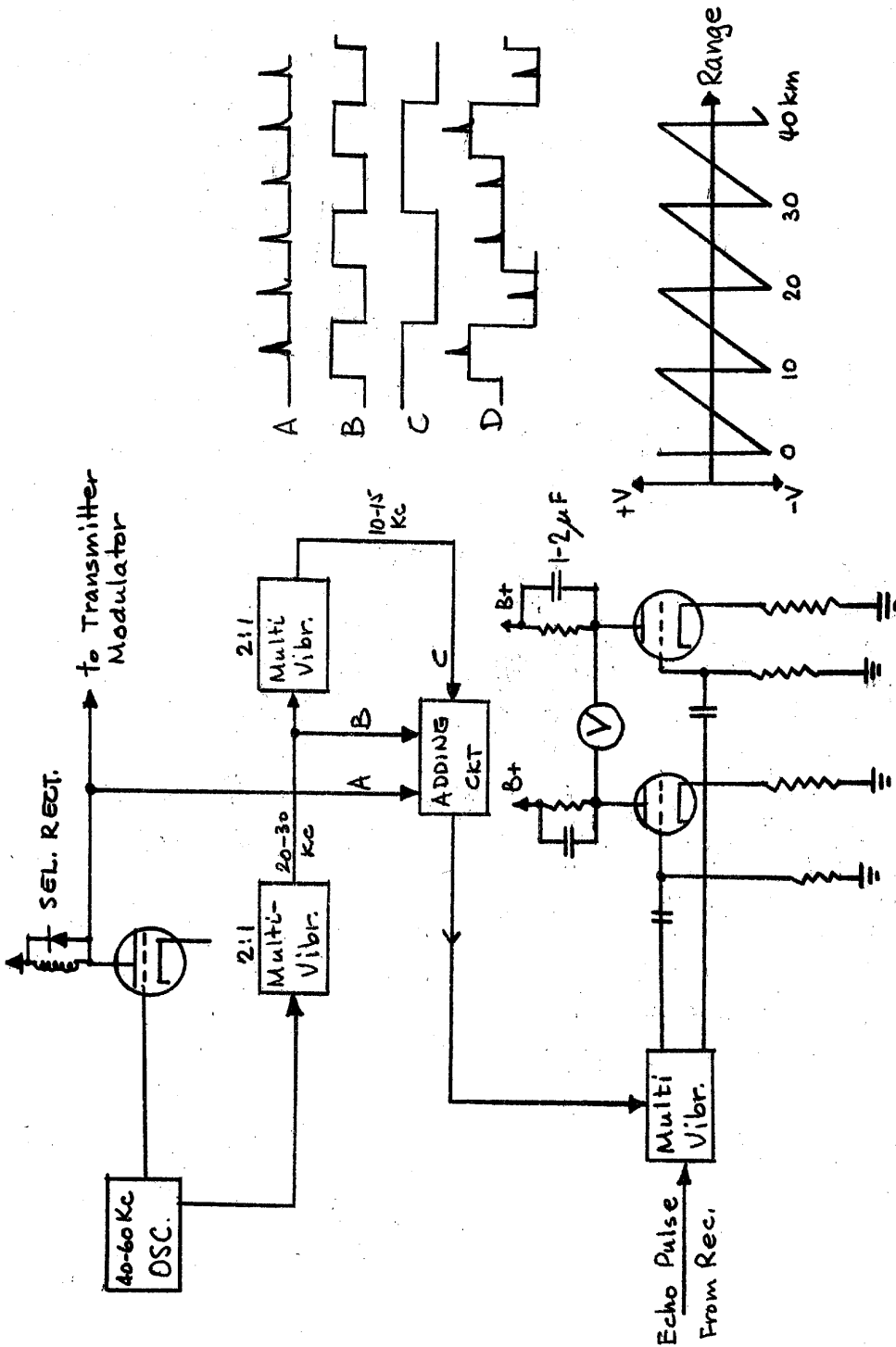

CIRCUIT & WAVEFORMS for RANGE MEASUREMENT

-SECRET-

SECRET



25X1

- 441 -

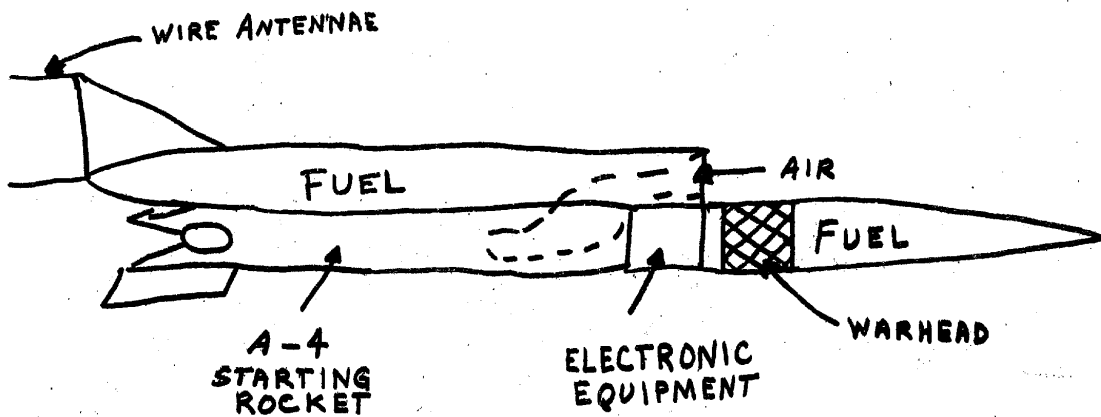
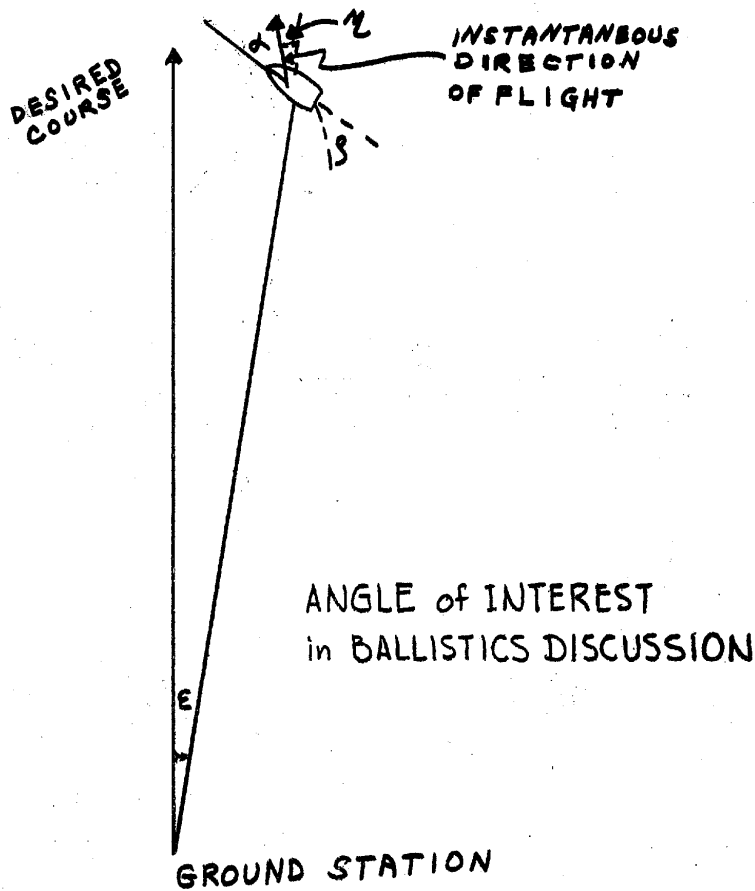

PROPOSED DESIGN of PILOTLESS, SUPERSONIC AIRCRAFT, R15

SECRET

-SECRET-

25X1

- 40 -

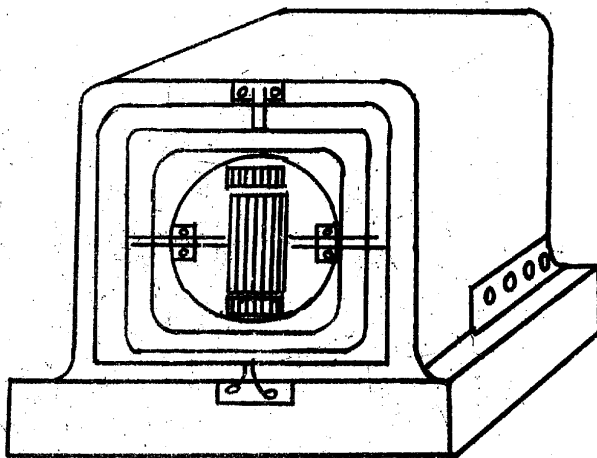

SKETCH of GYROSCOPE. Approx. Actual size

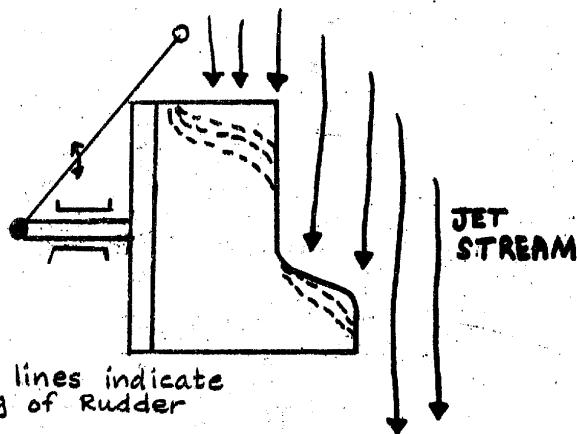

Dotted lines indicate burning of Rudder

SKETCH of RUDDER

SECRET

- SECRET -

25X1

- 39 -

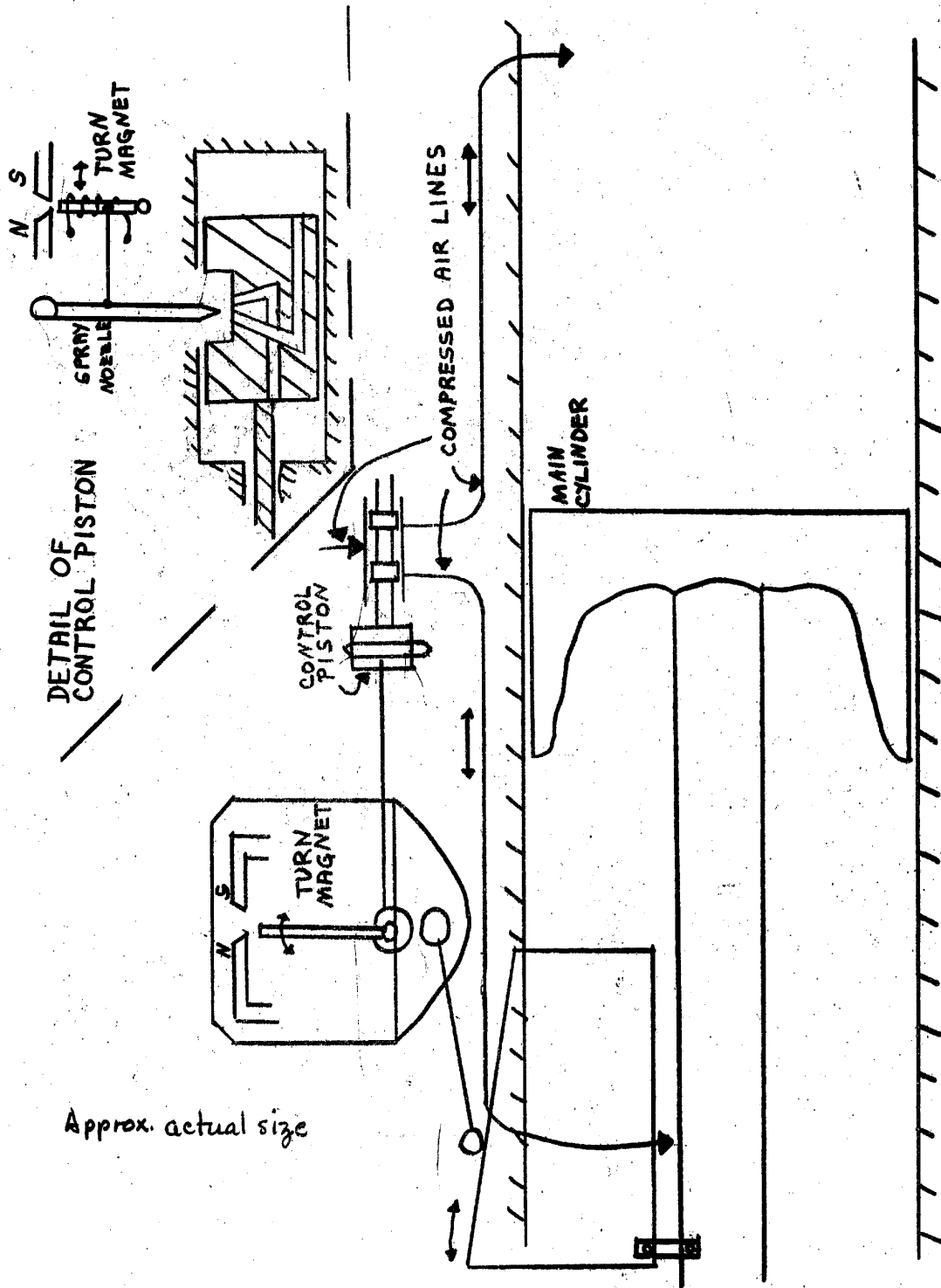

Approx. actual size

RUDDER ACTUATION EQUIPMENT

- SECRET -

-SECRET-



25X1

- 38 -

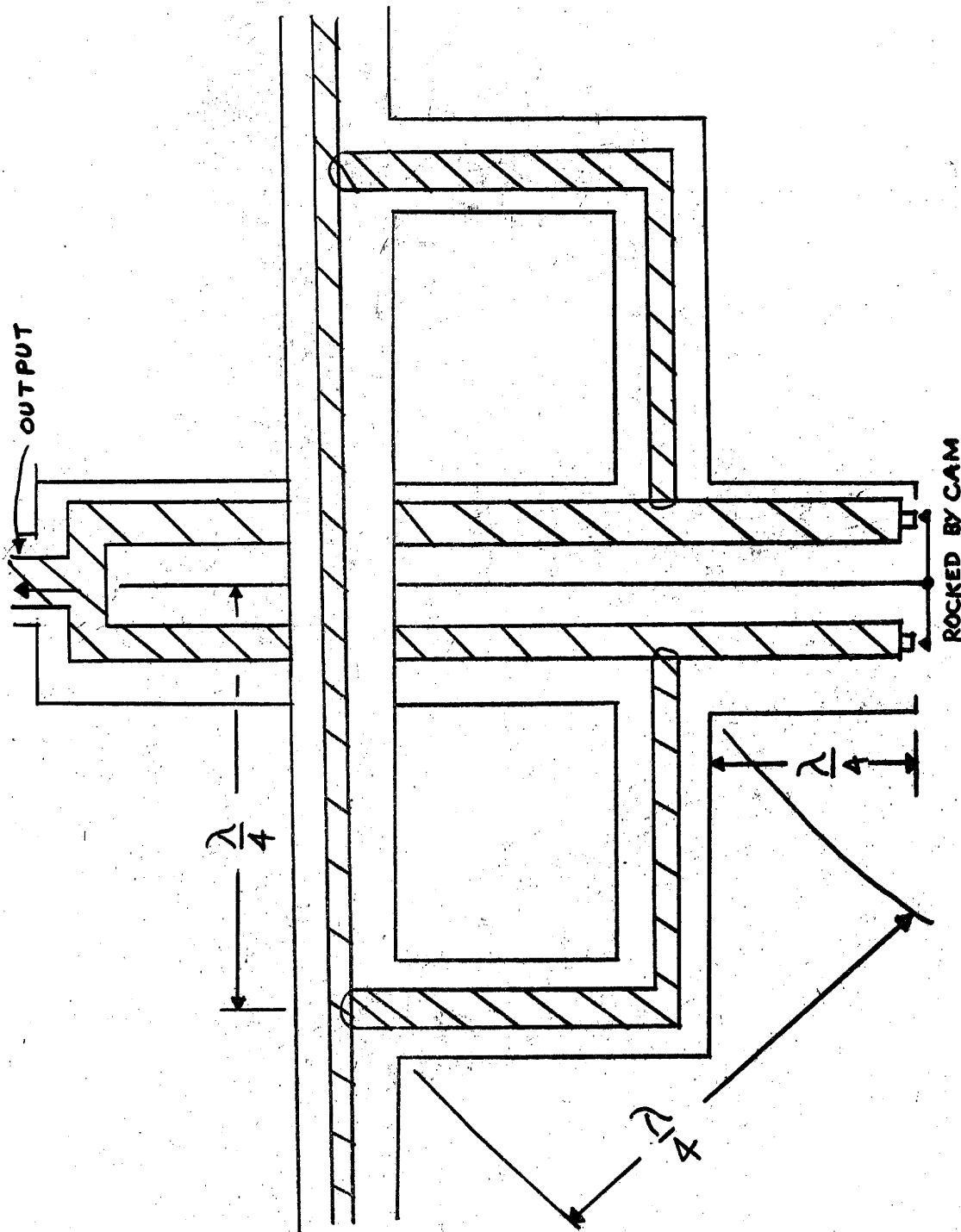

CONSTRUCTION of DIRECTION FINDING SWITCH
(ONE of TWO IDENTICAL SECTIONS)

-SECRET-



25X1

- SECRET -



25X1

- 37 -

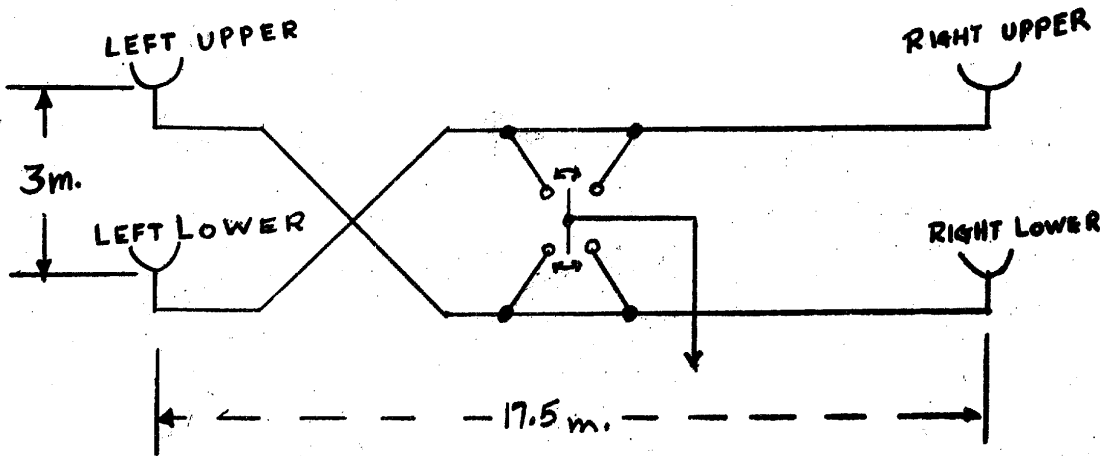

PART OF CYCLE	SWITCH POSITION	D.F. BY ANTENNAE
I		RIGHT
II		LOWER
III		LEFT
IV		UPPER

EACH PART OF CYCLE LASTS $\frac{1}{100}$ SEC.

ONE CYCLE = $\frac{1}{25}$ SEC.

SCHEMATIC REPRESENTATION
of DIRECTION FINDING SWITCH

- SECRET -