

25X1

Next 1 Page(s) In Document Exempt

25X1

India

**INDIAN INSTITUTE OF SCIENCE
BANGALORE**

WITH BEST COMPLIMENTS FROM



**REGISTRAR,
INDIAN INSTITUTE OF SCIENCE,
BANGALORE 3.**

*Professor M. S. THACKER, B. Sc. (ENGG.), M.I.E.E., F. Am. I.E.E., M.I.E., (IND.),
M.Inst.F., M.I.R.E., M.I.I.M., F.A.Sc., Director.*

**DEPARTMENT OF POWER ENGINEERING
HYDRAULICS AND CIVIL ENGINEERING SECTION**



**Director in Charge
Research Publication. No. 1**

**ANNUAL REPORT
1950**

*N. S. GOVINDA RAO, B.E., M.Am.C.Inst., M.I.A.H.R.,
Professor of Civil and Hydraulic Engineering,
and Staff.*

DEPARTMENT OF POWER ENGINEERING

Civil and Hydraulic Engineering Section

Director

Professor M. S. Thacker, B.Sc. (Engg.), M.I.E.E., F.Am.I.E.E., M.I.E. (Ind.),
M. Inst. F., M.I.R.E., M.I.I.M., F. A. Sc.,

Professor

N. S. Govinda Rao, B.E., M.Am.C.Inst., M.I.A.H.R.

Asst. Professors

Vacant.

Lecturers

Vacant.

Research Assistants

Sri H. C. Visveswarayya, B.E.

Research Scholars and Workers

B. S. Prasanna, B.Sc., B.E.

C. G. Ramaswamy, B.Sc., (Hons.)



Dr. Rajendra Prasad, President, The Republic of India and Visitor, Indian Institute of Science, laying the foundation Stone of the Civil and Hydraulic Engineering laboratories.



The Visitor planting a Tree near the Statue of the Founder of the Institute.

CONTENTS

| | PAGE |
|---|------|
| Chapter I | |
| INTRODUCTION | 8 |
| Chapter II | |
| PROPOSED HYDRAULIC AND CIVIL ENGINEERING LABORATORIES ... | ” |
| Chapter III | |
| USE OF ELECTRICAL ANALOGY TO DETERMINE HYDRAULIC PRESSURES ... | 16 |

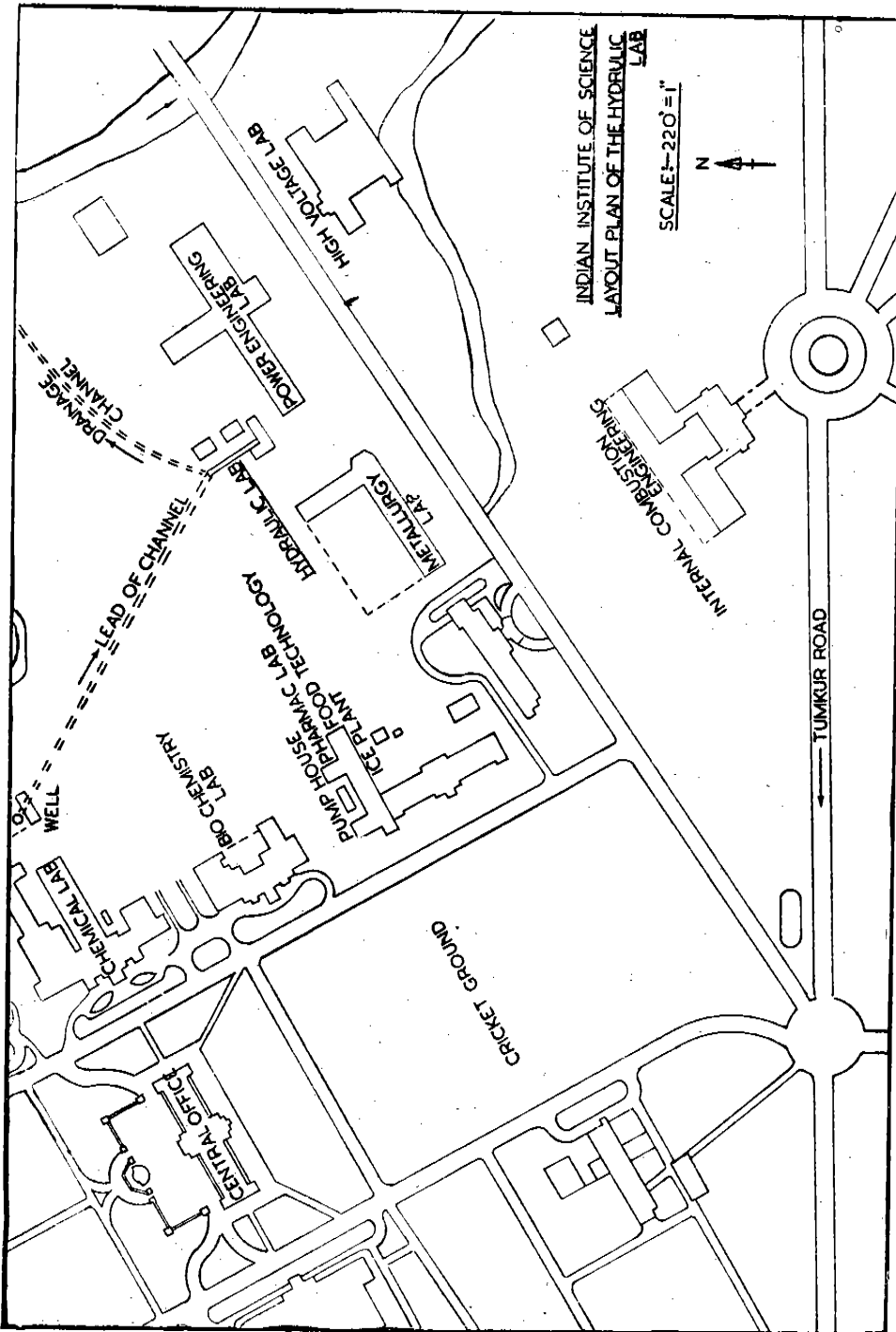

FIG. 1

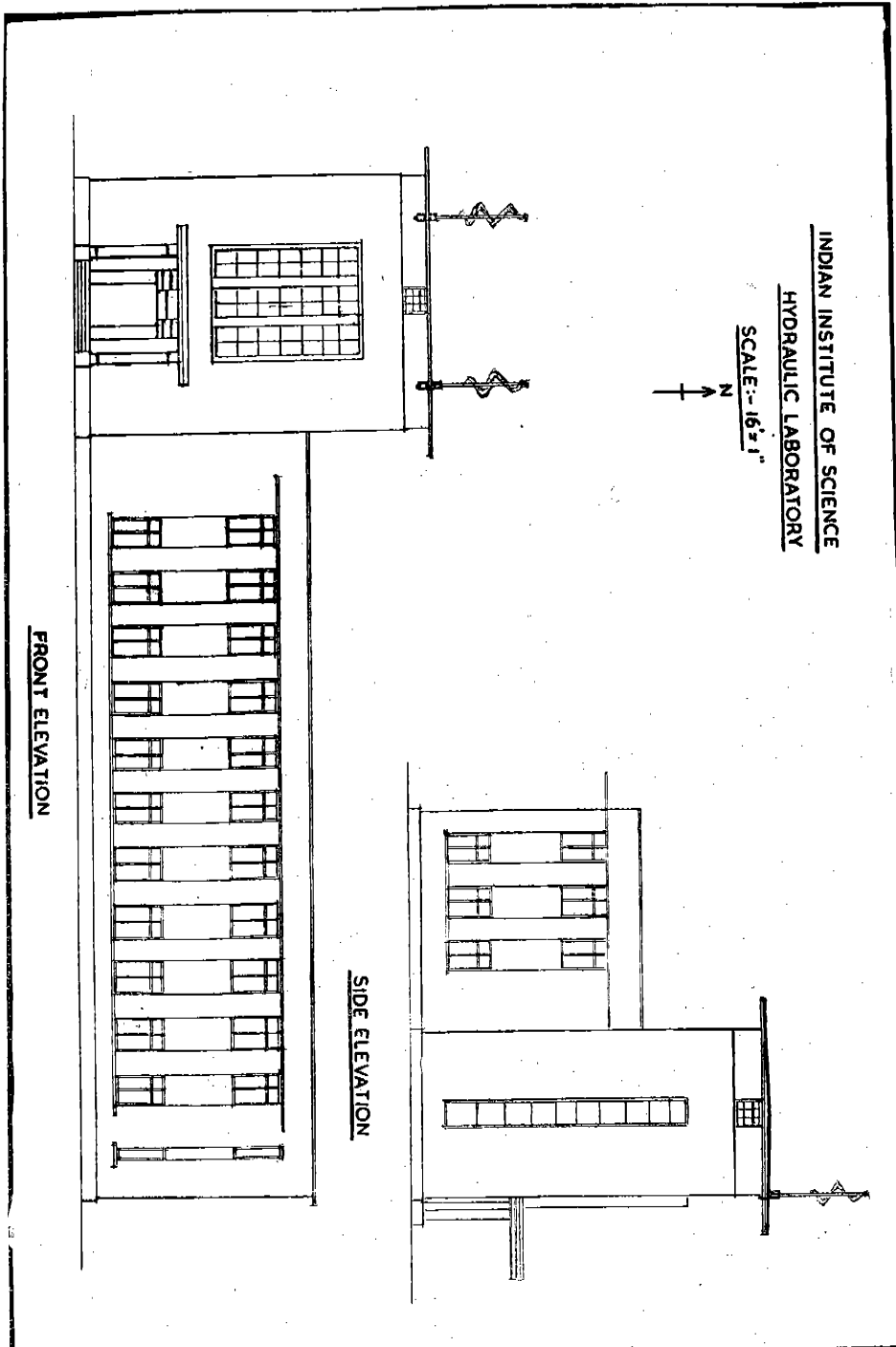
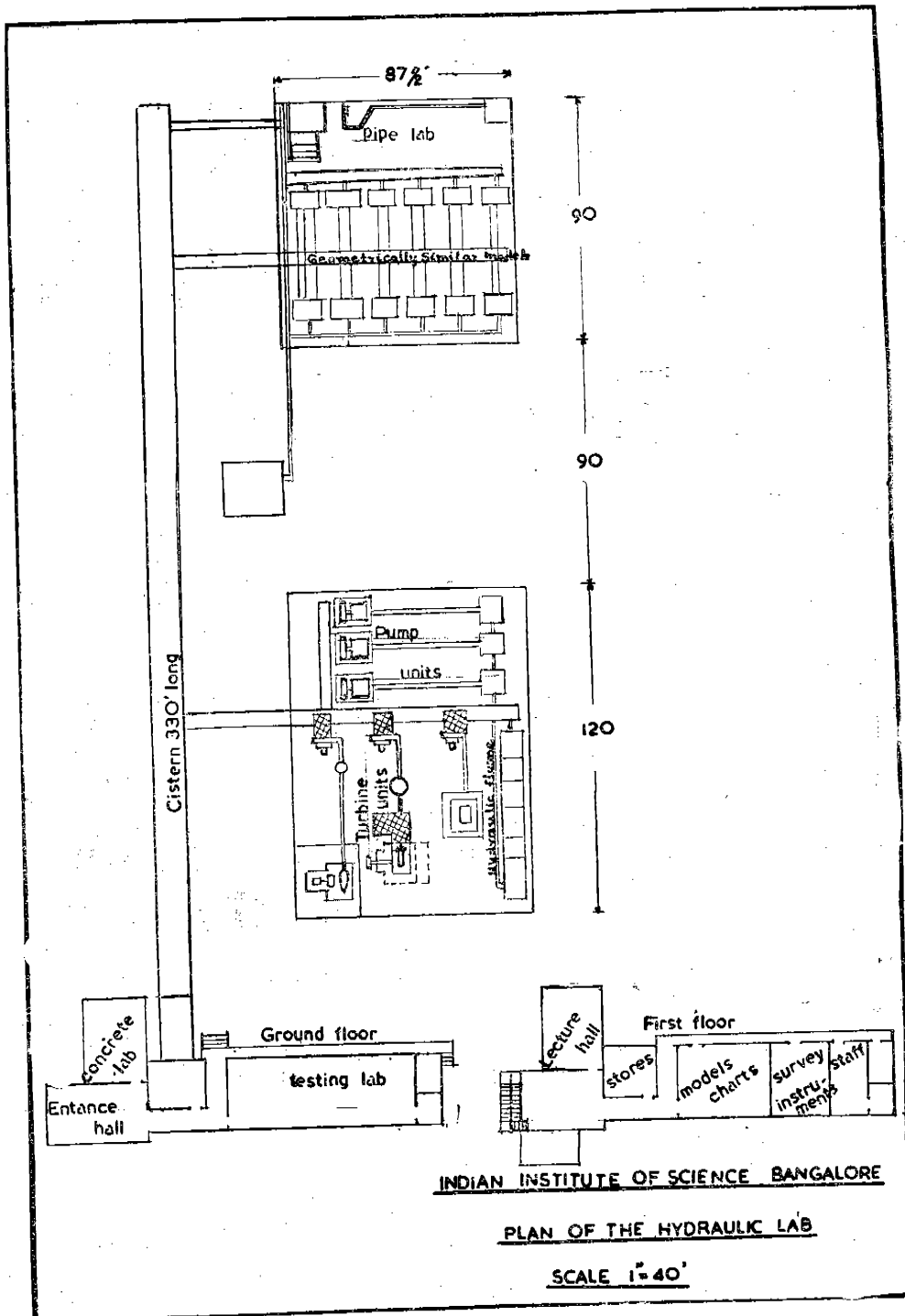

Fig. 2



CHAPTER I

Introduction

Mr. N. S. Govinda Rao was appointed as Professor of Civil and Hydraulic Engineering. He took over charge on 24th July 1950.

Other staff to the section is being recruited.

Prof. Govinda Rao attended the meetings of the Central Board of Irrigation, the World Congress on Large Dams, and the International Commission on Canals and Drainage and took part in their discussions.

The foundation stone for the Civil and Hydraulic Engineering Laboratories was laid by Dr. Rajendra Prasad, the President of the Republic of India and the Visitor to the Indian Institute of Science, on 10th January 1951.

During the year, schemes were drawn up for installing and equipping the following laboratories:—

- (1) Materials Testing Laboratory.
- (2) Hydraulic Machines laboratory, and
- (3) Soil Mechanics laboratory.

Investigations were started on determination of hydro-static pressures by electrical analogy methods.

CHAPTER II

Proposed Hydraulic and Civil Engineering Laboratories

The Civil and Hydraulic Engineering Laboratories are proposed to be equipped for doing basic research apart from giving advanced post-graduate training to students in the civil engineering branches as allied to power development. It will also undertake investigations on problems referred to by the power supply industry in the country.

The following laboratories are to be established:—

- (1) Hydraulic Machines laboratory.
- (2) Hydro - dynamics laboratory.
- (3) Soil Mechanics laboratory.
- (4) Materials Testing laboratory.

The Hydraulic Machines and Hydro-dynamics laboratories are for the present to be equipped with the following units only.

1. Turbines. A Kaplan turbine of a rated capacity of 30 H.P. working with a net head of 30 ft, a Francis Turbine of 20 H.P. capacity also utilising a head of 30 feet and a Pelton wheel developing 50 H.P. under a net fall of 300 feet; representative each of a low, medium, and high head type of turbine are to be installed. The Kaplan turbine will have arrangements for observation of cavitation conditions in its runners. A small unit to undertake basic research on high velocity flow to facilitate design of high head turbines will also be installed. In this unit, studies will be made of air entrainment in high velocity jets, the destructive action on various types of materials, and the behaviour of jets under high and low atmospheric pressures.

2. Pumps. The following types of pumps are proposed to be installed:— single stage low pressure centrifugal pump, horizontal multistage turbine pump, horizontal shaft axial flow pump, high lift high speed horizontal multistage centrifugal pump, reciprocating and other types of pumps. The following other units will be installed:—

- 3. Pipes,** to study friction losses in penstock pipes, bends, jets water hammer action etc;
- 4. Hydraulic Flume,** with glass sides and bottom capable of being adjusted to different slopes to study pressures at the foundations of and in hydraulic structures;
- 5. Siphons,** to study flow and pressures in siphons of various types;
- 6.** Geometrically similar models of gates, valves, high co-efficient weirs, standing wave flumes and venturi meter;
- 7. Gauges and meters,** of various types, manometers and current meters; and
- 8. Hydrodynamic models,** for solution of problems pertaining to training of rivers, and canals to safeguard hydraulic structures.

9. Soil Mechanics laboratory. This will be equipped with liquid limit device, Proctor's needle and compaction apparatus, unconfined compression testing apparatus, direct shear and tri-axial shear testing apparatus, California bearing test equipment, and augers and drilling equipment for taking out samples. These are in addition to the other laboratory articles of common use.

10. Materials Testing Laboratory. These include apparatus for testing cements and concrete as well. They consist of a 200 ton Avery's Testing Machine, Brinnel's Hardness Testing machine,

INDIAN INSTITUTE OF SCIENCE, BANGALORE

HYDRAULIC LAB

KAPLAN-FRANCIS TURBINE

| | | | | |
|----------|-------------|---------|-------------|---------------------------------|
| <i>H</i> | 30' | Francis | 30" | Centrifugal Pump |
| <i>Q</i> | 10.8 Cusecs | | 7.06 Cusecs | <i>M</i> max . 65.62 |
| <i>N</i> | 30 R.P.M. | | 19.5 R.P.M. | <i>Q</i> 113 Cusecs |
| <i>W</i> | 2500 f.p.m. | | 1200 f.p.m. | <i>M</i> 107 H.P. N=nd 125 H.P. |
| | | | | <i>W</i> 970 f.p.m. |

- 1 Francis Kaplan Turbine
- 2 Water level indicator
- 3 Current Meter
- 10 Venturi Meter
- 13 Centrifugal Pump
- 14 Air Tank
- 11 Discharge Valve
- 12 Speed Governor

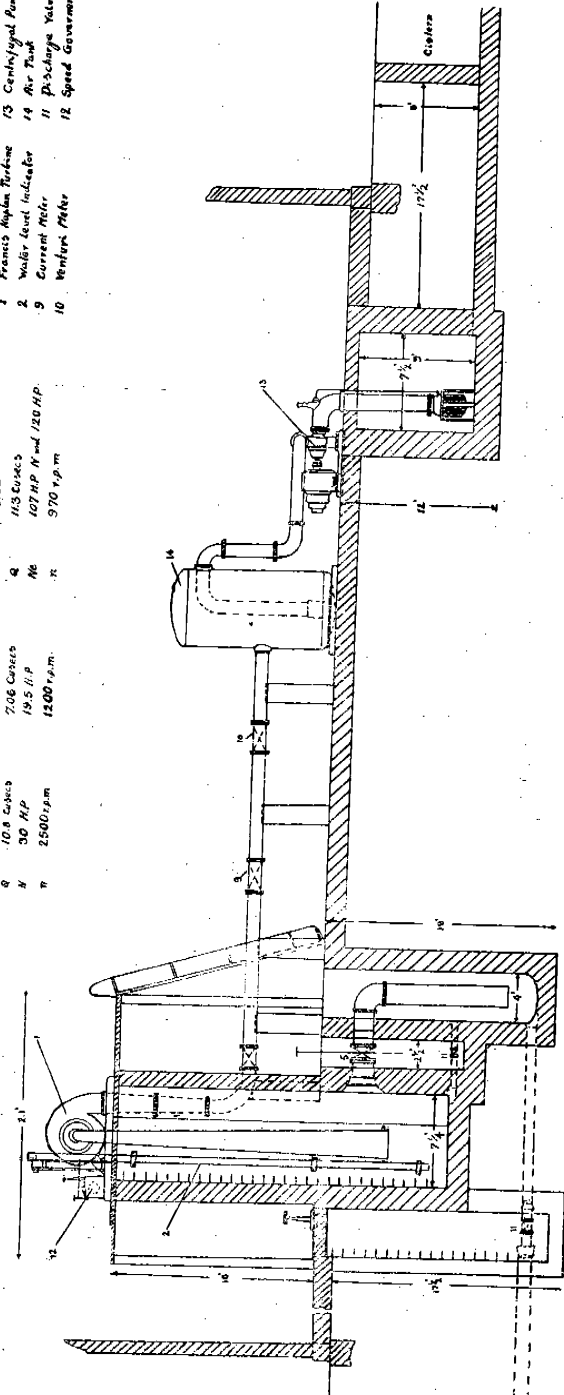

INDIAN INSTITUTE OF SCIENCE BANGALORE
HYDRAULIC LAB

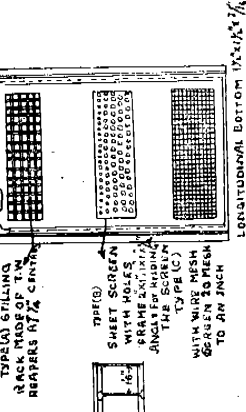
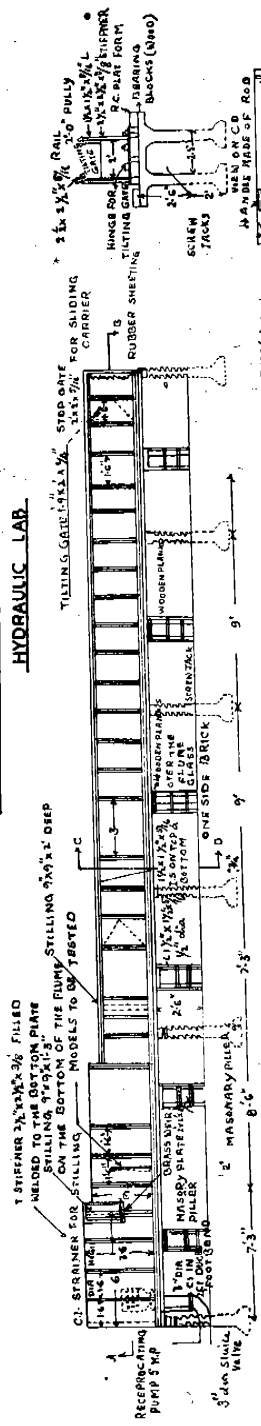

SECTION (A) LONGITUDINAL BOTTOM VIEW ON G.H. SCALE 1/8"

SECTION (B) SCALE 3/16"

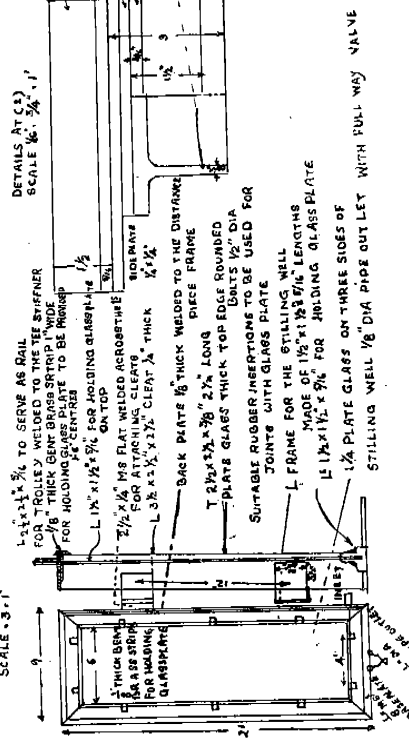

DETAILS AT (C) SCALE 1/4"

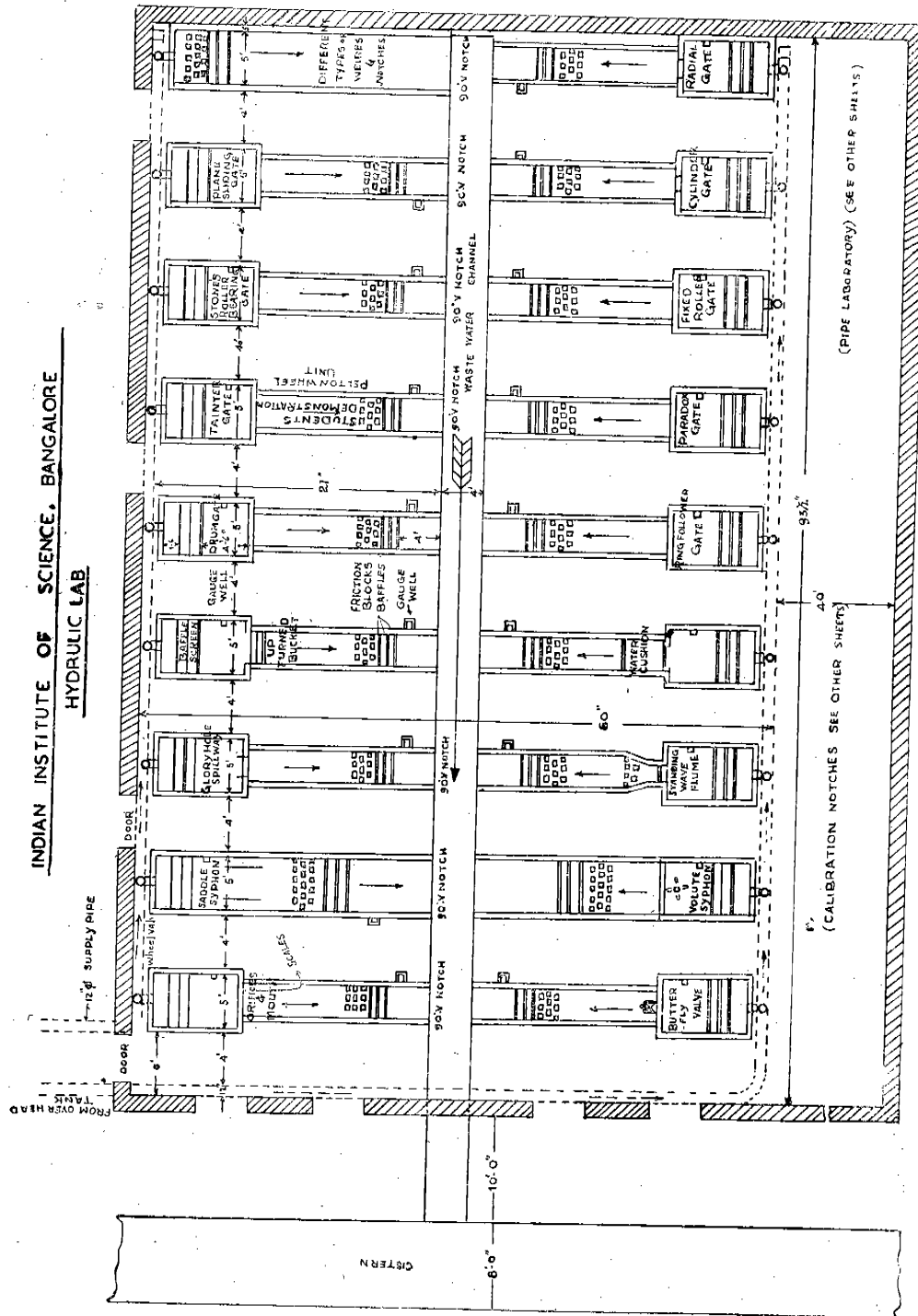

INDIAN INSTITUTE OF SCIENCE, BANGALORE
HYDRAULIC LAB

Sections of Geomorphically Similar Models

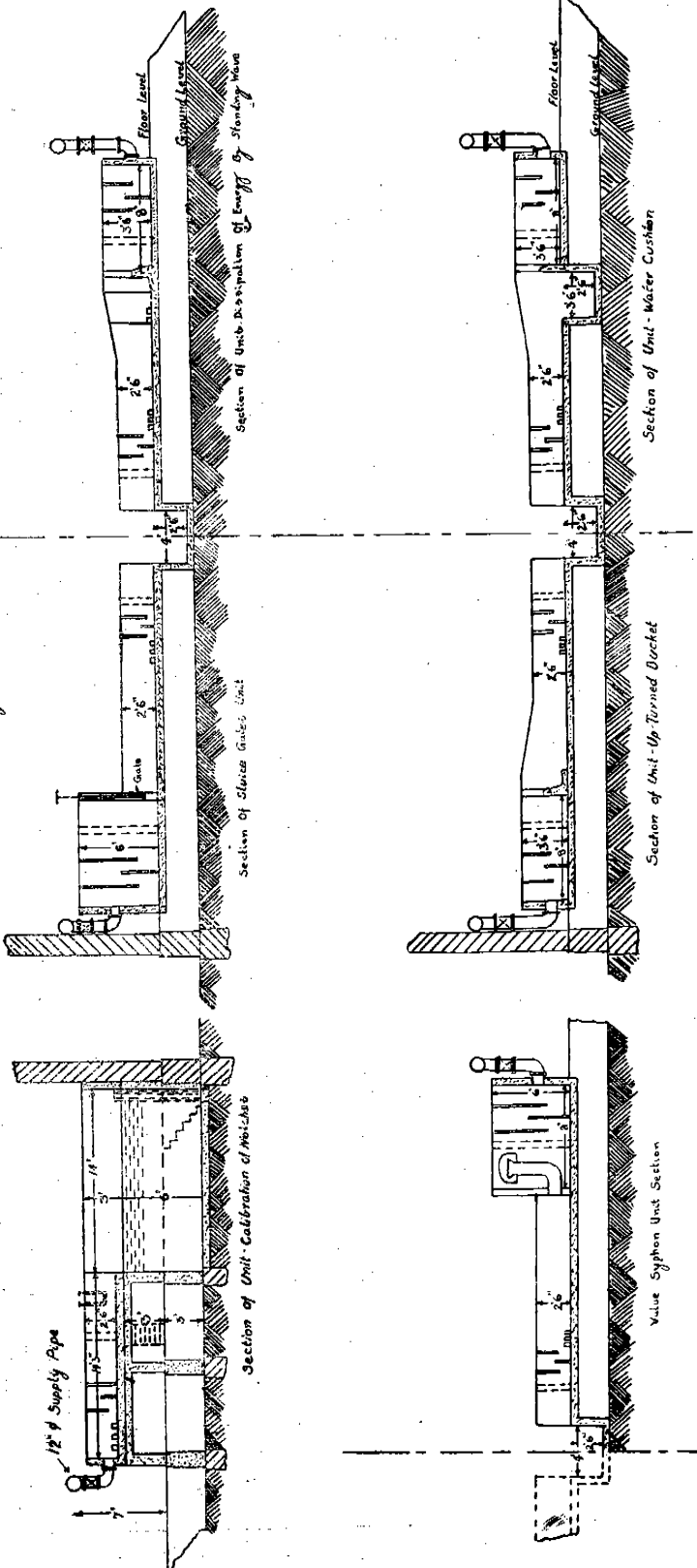

INDIAN INSTITUTE OF SCIENCE, BANGALORE

HYDRAULIC LAB

PIPE EXPERIMENT UNITS & NOTCH CALIBRATION UNIT

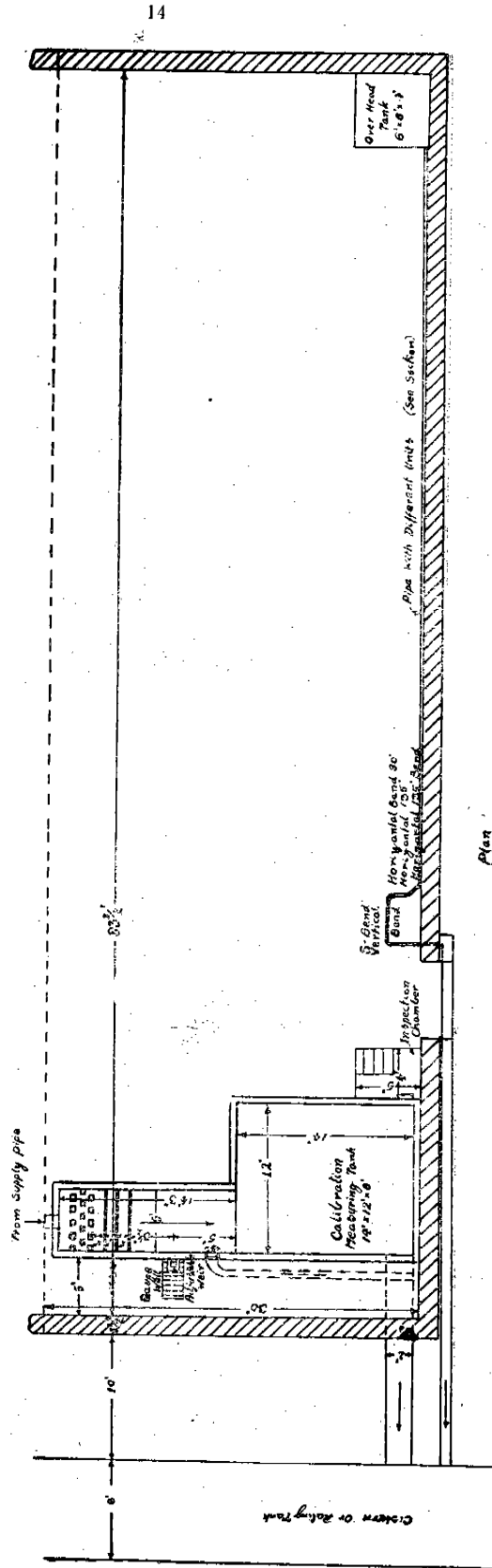

INDIAN INSTITUTE OF SCIENCE, BANGALORE

HYDRAULIC LAB

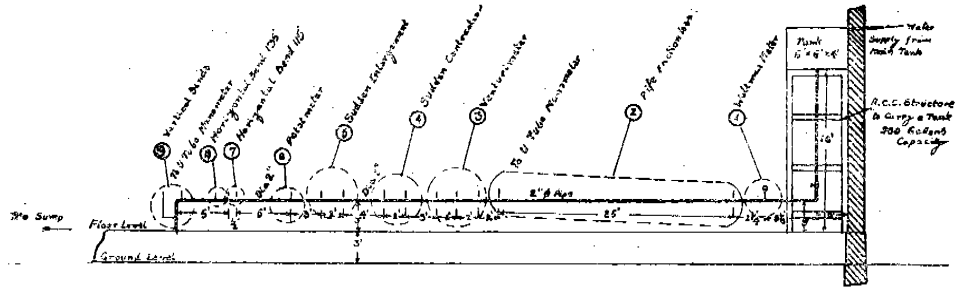

PIPE LABORATORY

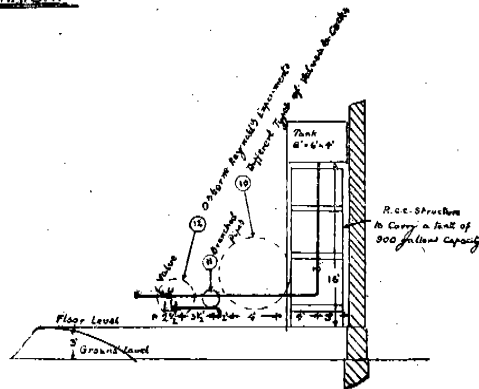

Amsler's Horizontal Tensile Testing machine, Avery's Dynamic balancing machine, Amsler's Pendulum type Impact machine, Avery's spring Testing machine, wear and Lubricant Tester, Cement Testing Machine, Vicat needle apparatus, Initial Time of setting apparatus, Amsler's shrinkage Tester, Amsler High Frequency vibrophore, etc.,

Location of the laboratories. To ensure perfect co-ordination between the various units of Power Engineering buildings which have already been built, it is proposed to locate these laboratories between the present Metallurgy and Power Engineering Blocks (*vide* fig. 1). This will allow for expansion of different units and also provide ample space for layout of hydrodynamic models of hydel projects. They will be quite close to the lecture rooms which are located in the Power Engineering blocks. There is a well just close to the laboratories containing enough water (estimated at about 50,000 gallons) for all ordinary requirements. Water can be pumped from the well to the cistern, in the shape of a rating tank in front of the laboratories. The cistern (*vide* fig. 3) will have a capacity of 100,000 gallons and can eventually be used as a rating tank for calibrating meters. An overhead tank of 25,000 gallons capacity will also be built to work all geometrically similar and other models. Pumps which form part of the turbine and other units will be used for pumping water from the cistern to the overhead tank, and one of them for pumping water from the well to the cistern.

Buildings. The buildings (fig. 2 and 3) will consist of a masonry block in front with two laboratory halls in rear.

The masonry block will house the Soil Mechanics, Concrete and Materials Testing laboratories. One of the laboratory halls will house the turbine and pump units while the other will house the remaining units.

11. Full Equipment for the Hydraulic Machines Laboratory:—The proposed laboratory is just sufficient to start research on limited problems in a restricted way on hydraulic machines, that is on turbines, pumps, and basic research on flow hydraulics. Even in these lines, research of a type which can directly assist the existing pumps manufacturing industry or in starting a turbine or high pressure gates and valves industry, will not be possible without a cavitation research unit. It is necessary that steps are taken to procure this equipment immediately in view of its importance in hydraulic research. The necessary finance must be found if the hydraulic laboratory should promote national interests.

For lack of finances, orders for this very important equipment cannot be placed. Similarly orders for units like those of hydraulic cranes, hoists, intensifiers, accumulators, servo mechanisms, other types of pumps and turbines different from those ordered for, hydraulic brakes, hydraulic power transmission units etc., cannot be placed for lack of funds.

Unique facilities exist at the Institute. The wind tunnel, photo elastic apparatus etc., in the aeronautical department, the equipment in the Metallurgy, Chemical Technology and Internal Combustion Engineering and Power Engineering Departments with their expert personnel are available to aid hydraulic machines research. It will be extremely costly both to set up elsewhere a separate laboratory, and to get the aid of laboratories and personnel allied to hydraulic research of the type that will be possible at the Institute.

If further funds could be diverted to purchase of equipment, a complete laboratory good enough to undertake investigations of all problems likely to arise in hydel projects and hydraulic machines (Pumps, turbine gates, valves, etc.) manufacturing industries can be set up. Such diversion of grant and co-ordination of effort would be in the best interests of the country.

CHAPTER III

Use of Electrical analogy to determine hydro-static pressures

The Laplace equation for solution of problems involving a field, flow lines and potential (gradient causing flow) is being used in many problems in Science and Engineering.

Consider for example the flow in a channel with uniform velocity. A stream line in the channel can be considered as a one dimensioned field. As the velocity is constant, the change of potential with length is also constant. That is $\frac{d\phi}{dx} = \text{constant}$, where ϕ is the hydraulic potential at the point under consideration.

$$\text{Since } \frac{d\phi}{dx} = \text{constant, } \frac{d^2\phi}{dx^2} = 0.$$

For a plane where two dimensional flow of water is considered, the equation becomes $\frac{d^2\phi}{dx^2} + \frac{d^2\phi}{dy^2} = 0$

and for three dimensional flow, this equation is $\frac{d^2\phi}{dx^2} + \frac{d^2\phi}{dy^2} + \frac{d^2\phi}{dz^2} = 0$.

An equation of the same form is also applicable to stream flow lines so long as continuity of flow is maintained and the flow is irrotational. For completely expressing the properties of this field of flow, it is necessary to find (a) a potential function satisfying the boundary potential functions and expressing the distribution of potential throughout the field, and (b) a flux or stream function characterising the lines of flow from source boundary to sink boundary.

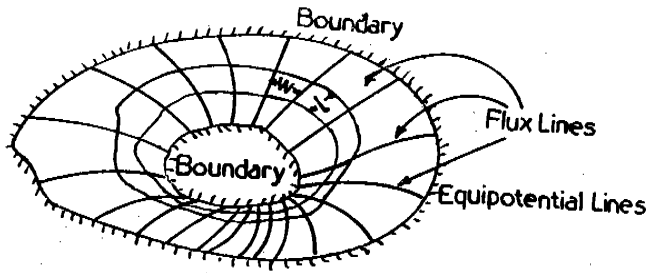

FIG. 11

Both of these functions must satisfy the Laplace equation.
The following table gives a list of fields obeying this equation.

| Field | Flow lines | Vector Quantity | Scalar Quantity. |
|--------------------------------|---------------------|-----------------------------------|--------------------------|
| Newton's gravitational field.* | Gravitational flux. | Gravitational potential gradient. | Gravitational potential. |
| Electric. | Electric flux. | Electric flux density. | Electric potential. |
| Magnetic. | Magnetic flux. | Magnetic flux density. | Magnetic potential. |
| Conduction. | Current. | Current density. | Electric potential. |
| Thermal. | Rate of heat flow. | Temperature gradient. | Temperature. |
| Hydraulic. | Hydraulic flux. | Hydraulic gradient. | Hydraulic potential. |

*Gravitational flux and gravitational potential gradient are entirely conceptual and have no physical significance.

Fields in two and three dimensions. In a field plot let L be the mean length of an element between successive equipotential lines, w the mean width between flow lines and d the mean depth. Then for a medium of resistivity ρ , every element conforms to $\rho l/wd = \text{constant}$ where *resistivity* is defined as the ratio of the hydraulic pressure to the discharge per second through a channel of unit cross section. In a two dimensional plot d is fixed so that $\rho l/w = \text{constant}$. In a three dimensional case with an axis of symmetry, the depth of an element depends on the radius r from that axis so that $\rho l/w = \text{constant}$.

For two dimensional fields in a single homogenous medium, the number of equipotential and flux lines plotted may be so chosen that $l=w$; the plot then consists of curvilinear squares, the lines cutting each other orthogonally.

Analytical methods to the solution of the Laplace's equation are by separation of variables, conjugate functions and conformal transformations.

Several numerical methods have been developed recently by which potential distribution can be found for any boundary shape with any degree of accuracy. They are due to H. Liebmann, A.O. Muller, Shortley and Weller and Kornes (1). Southwell's relaxation technique developed by Southwell (1) and his school has proved to be much faster and more powerful than all the others.

The method of graphical field plotting is usually confined to two dimensional cases and is capable of considerable accuracy. The process is begun on a scale drawing of boundaries with assigned potentials by plotting any suitable number of intermediate equipotential lines. Flux lines are then drawn to cut the equipotential lines orthogonally and to form curvilinear squares. The errors are corrected by systematic improvement and the use of curvilinear squares has the advantage of easy recognition and checking. A. D. Moore, Willoughby, and Poritsky, Hepp and Hutter have done considerable work on this aspect. (2), (3), (4), (5), (6).

Analogy methods. Amongst the various experimental methods, the analogy developed between the flow of fluid and the flow of electric current under identical boundary conditions seems to be the most accurate. The idea of using a probe to follow equipotential lines was first used by Kirchoff in 1845. An electrolytic tank was employed by Adams in 1875. The method has been further developed by numerous workers during the last fifty years and applied to many problems in electro-statics, hydrodynamics, aerodynamics etc.

→
"It is well known that according to ohms law, the current density J is proportional to the electrical field strength E . $J = \sigma E$ (1) Where σ is the conductivity of the medium. Taking the

divergence of the above equation we get, divergence $J = \text{divergence } \sigma E = 0$.

The general properties of the electro magnetic field are expressed by Maxwell's equations. For static or quasi static fields, they reduce to $\text{div. } E = 4\pi\rho$ —(2). It is clear from the identity of these two equations (for $\rho=0$), that the flux tubes of electric current between electrodes immersed in a medium of conductivity are identical with tubes of electric force between the same electrodes embedded in an insulating medium of dielectric constant E and that the orthogonal surfaces *i.e.*, the equipotential surfaces are identical in the two cases. It follows from the linearity of the equation that a scaling up or down of the electrode structure or proportional changes in the electrode voltages leave the geometry of the pattern of the flux tubes and equipotential surfaces unchanged."(1).

To carry the analogy into effect models of the electrodes are immersed into a tank filled with a weak electrolyte. It may be ordinary weak solution of salt water, sometimes a thin foil of copper or silver is employed.

A diagram of the basic circuit is given in fig.12.

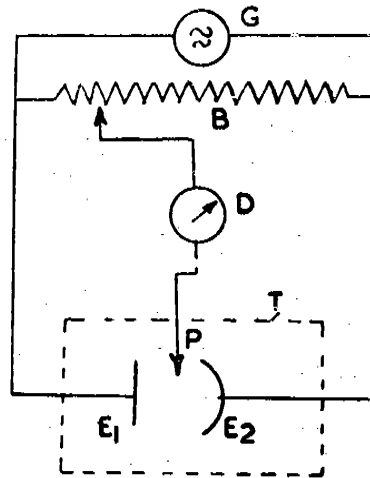

Fig. 12.

The investigation of axially symmetric systems is often simplified, if a tank with inclined insulating bottom is employed. The two insulating planes, namely the bottom of the tank and the free surface of the electrolyte cut out a volume of electrolyte of sector shaped cross section. The line of intersection of the two planes is the axis of the system. The field distribution within the wedge of the electrolyte is then the same, in view of the reflection in the insulating boundary planes, as that within the full cylinder.

Electrolytic Tanks. The electrolytic tank comprises of a rectangular tray 30 inches and 20 inches and one inch deep. The tray or tank has insulated bottom and walls. In considering problems connected with axially symmetric systems, the tank can be tilted for use as an inclined tank. In most of the problems connected with the study of the flow of water, the problem can be simplified to a two dimensional one; hence an electrolytic tank with a flat bottom without any tilt is used.

The model to be investigated is of an insulating material and fixed in position in the tank. The walls of the tank usually introduce slight errors due to reflection. This can be overcome by so choosing the dimensions of the tank as to minimize the effects of the boundary below a certain value which can be neglected.

The *probe*, that is used for the exploration of the equipotential lines should be a thin copper wire projecting from a shielded insulated sleeve. A marking stylus is rigidly connected to the probe through a pantograph arrangement. The stylus runs on the drawing board in the same manner as the probe in the electrolytic tank. The stylus arrangement consists of a pencil supported by a spring which when passed marks on the drawing sheet.

For conducting the experiment the tank is first filled up at the centre of its upper side with the model of the dam or any other structure in the vicinity of which the flow net is to be drawn (*vide* fig.13). On either side of it are two thick copper electrodes. These are connected to a 110 volt alternating current through an adjustable rheostat to reduce the voltage drop across the terminals to about one volt. At the opposite side of the tray, is a potentiometer wire 100 cms. in length, each end of which is connected to one of the terminals by a heavy copper wire. On this potentiometer wire a sliding contact connects an oscillograph from which a wire is taken to a probe immersed in the tank. The probe is rigidly connected to a pantograph arrangement (not shown in the fig.) as already described. The tank is accurately levelled and filled with three quarters of an inch in depth of salt water.

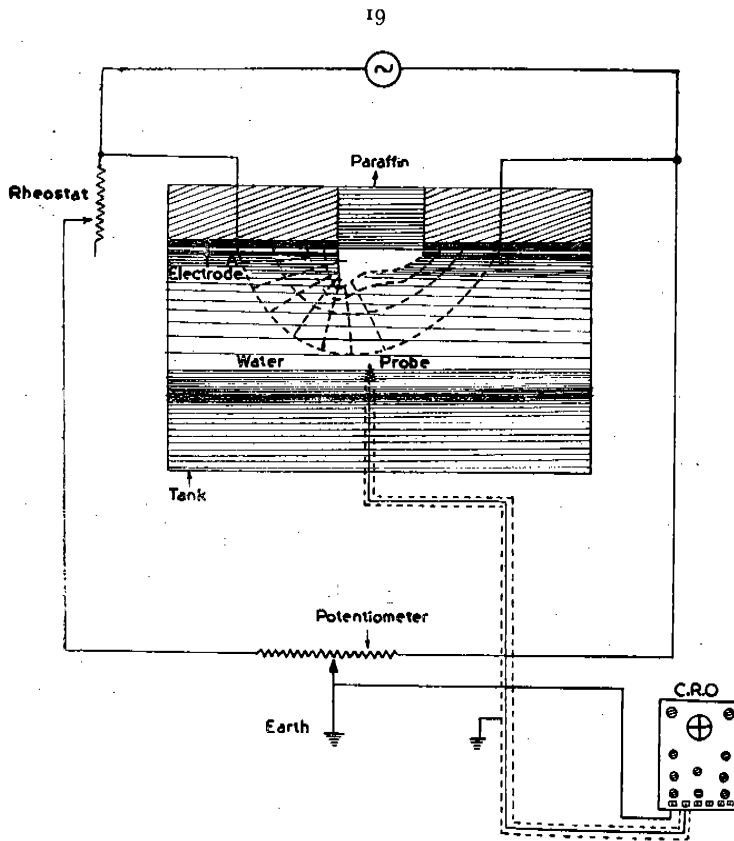

FIG. 13

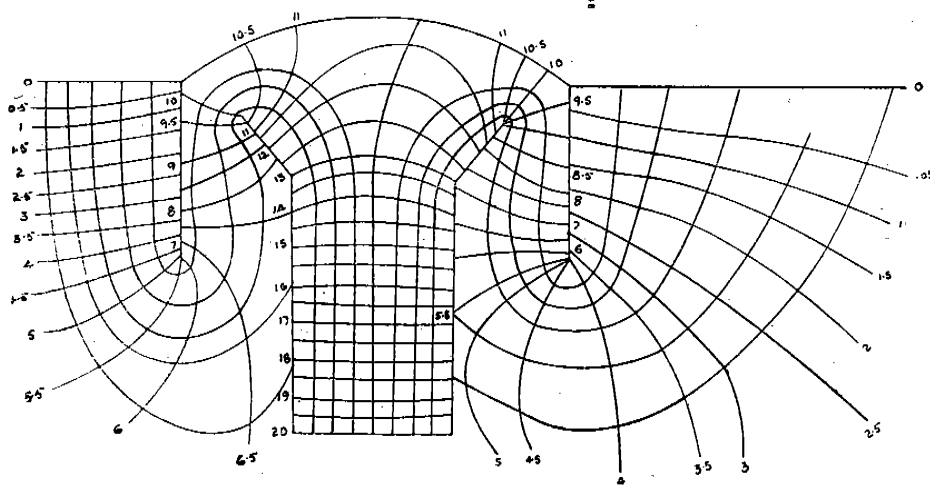

FIG. 14

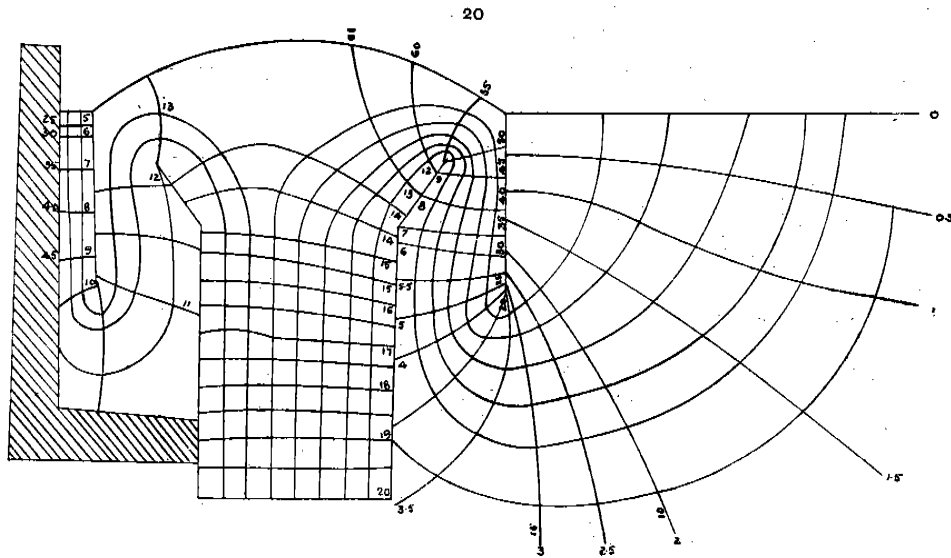

FIG. 15

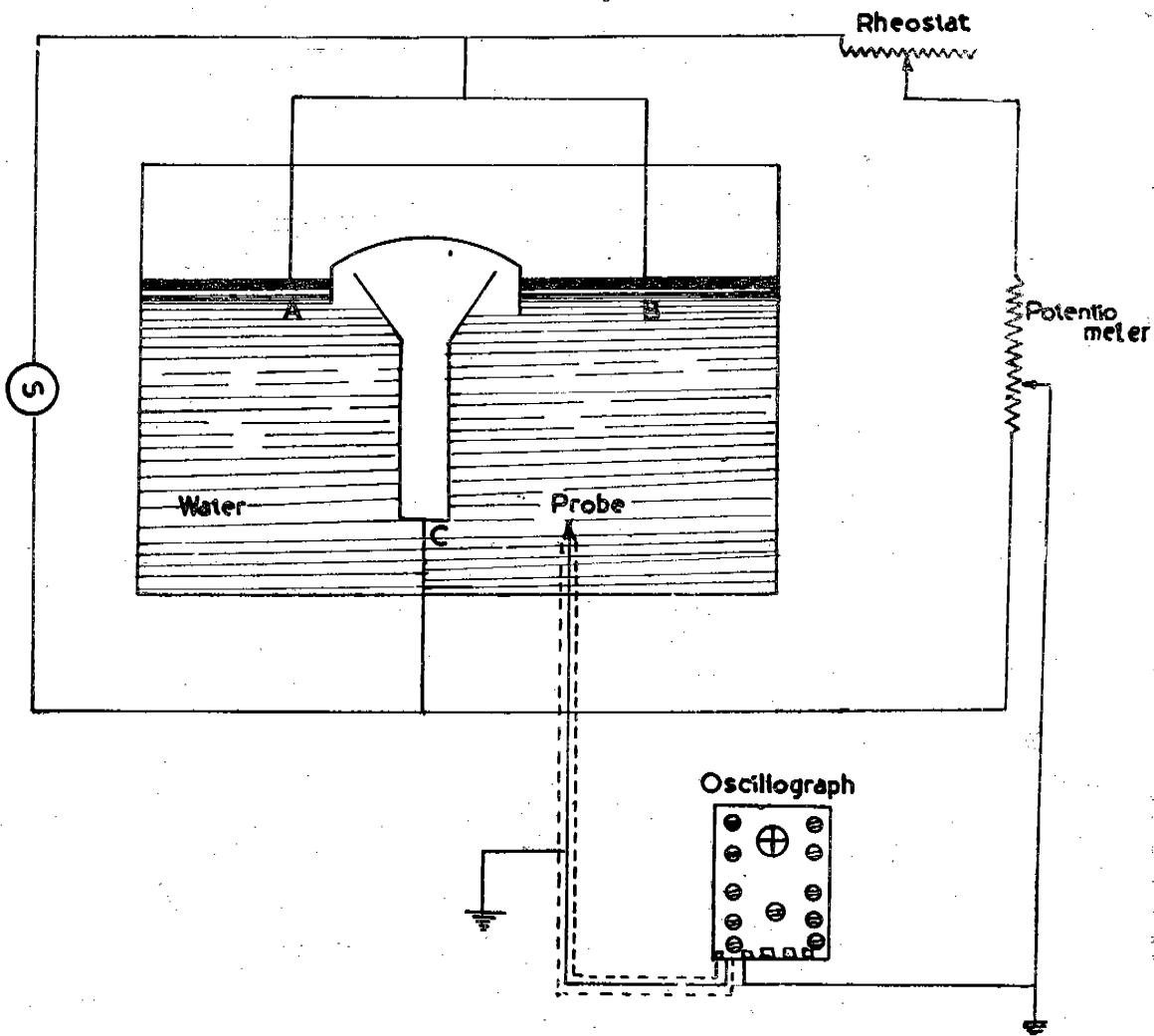

FIG. 16

In passing from one terminal plate to the other the current follows paths shown in dotted lines in fig. 13. Other lines crossing these orthogonally represent lines of equal potential for increments of five percent of the total potential drop. For the determination of any equipotential line, for example, the 20 per cent line, the potentiometer is set at 20 per cent and the probe is run in the tank exploring equipotential points which are located when there is no voltage recorded on the oscillograph. The connection that goes to the probe from the earth terminal of the oscillograph is completely shielded to overcome spurious errors. The several equipotential points that are got are joined by a smooth curve which gives the equipotential line. Similarly the other equipotential lines at steps of five per cent are drawn. The flow lines are then drawn free hand. It can also be drawn in the same way as the equipotential lines, by suitably altering the circuit.

Estimates of the accuracy of this method depend on the electrode materials, the electrolytes and the frequency of the power supply. By selecting favourable electrode materials like silver plated copper and electrolyte like 0.5% sodium carbonate solution, at a frequency of 300 cycles per second an accuracy of the order of 0.5% is said to be possible. The machining and positioning of the electrodes is a mechanical precision job. The probe should be very fine and its position and depth must be accurately defined and reproducible. Surface tension distorts the surface of the electrolytes at the electrodes particularly if the liquid does not wet the electrodes evenly, and at the probe if this is not fine enough. In consequence the field is distorted near the electrodes. Surface tension is also rather troublesome in inclined bottom tanks reducing the accuracy of the measurements near the axis.

Automatic marking of the equipotential lines on light sensitive paper by a light pointer attached to the probe was proposed by Ehrenfried (6). The cartographic unit, as it is called, has been successfully used to plot electron lens fields, flux distribution around armature teeth and the fields within vacuum tubes. Green has recently devised an even more accurate apparatus. (7).

Use of the Electrolytic tank in hydraulics. It has been widely used to determine the pressures and the velocities of sub-soil flow under dams and other hydraulic structures. The analogy between Darcy's law and ohm's law is made use of: According to Darcy's law, the velocity of seepage is directly proportional to the loss of head. The equation of flow, from this law is the equation of viscous or laminar flow, and has the same form as ohm's Law for flow of electricity in a conductor. A measurement of potential will by analogy give the head.

In applying the results of these experiments to actual proto type conditions it should not be forgotten that the electrolyte represents an ideal homogenous strata which is never met within the proto type. (12). If the velocity of seepage is high the flow may no longer be laminar.

It has been used to determine the flow net lines around hydraulic structures, like siphons, high coefficient weirs and bell mouth entrances to sluice vents in dams etc. The dimensions of volute siphons as used at Herebhasgar in Mahatma Gandhi Hydro Electric Project was taken and reproduced in an electrolytic tank.

Fig. 14 shows the flow net for the condition of flow without a dam.

Fig. 15 shows the flow net for the condition of flow with the dam but without the outlet bend. It will be seen there from that in the case of a siphon (a) the flow into it on the side away from the dam (off side) is very much more than from the dam side, (b) the maximum velocity is at the lip on the off side after the siphon has started functioning. Further investigations are under progress.

Alternative experimental methods. A commonly used alternative is the rubber sheet method. This relies on the fact that for small vertical displacements "h" of a horizontal stretched membrane, uniformly tensioned and sag free,

$$\frac{d^2 h}{dx^2} + \frac{d^2 h}{dy^2} = 0$$

Hence, if two plane edges representing the conductor boundaries of the field under examination are used, one to restrain the sheet horizontally and the other to give a uniform vertical displacement of the rubber sheet corresponding to the difference in potential of the two boundaries, the contours of equal height on the rubber sheet will represent the equipotential surfaces and the slope of the sheet will represent the field intensity.

Another method is that of magnetic analogy. This method has so far been only qualitative. The pattern of equipotential lines can be obtained.

Electrical Resistor network is also employed in the solution of problems connected with field theory. (9).

The authors express their grateful thanks to the guidance given by the Director Prof. M. S. Thacker.

BIBLIOGRAPHY

- | | | | |
|--------------------------------------|-----|-----|--|
| 1. Marton | ... | ... | Advances in Electronics. |
| 2. A. D. Moore | ... | ... | Fundamentals of Electrical Design. |
| 3. Willoughby | ... | ... | Journal of Institution of Electrical Engineers Part III, Vol. 93. 1946. |
| 4. Poritsky | ... | ... | Transactions of the American Institute of Electric En- gineers. Vol. 157. 1938. |
| 5. G. Hepp | ... | ... | Philips Technical Review. Vol. 4. 1939. |
| 6. Ehrenfried | ... | ... | American Journal of Physics. Vol. 12. 1944. |
| 7. Green | ... | ... | Review of Scientific Instruments. Vol. 19. 1948. |
| 8. Say | ... | ... | Bulletine of Electrical Engineering Laboratory Practice. 1948. |
| 9. Jacob | ... | ... | Philosophical Magazine. Vol. 25. 1938. |
| 10. Paschkis | ... | ... | Proceedings of the Society for Experimental Stress Analysis. Vol. 2. No. 2. |
| 11. M. S. Thacker and B. S. Prasanna | ... | ... | Electronics. Vol. 23. |
| 12. E. W. Lane | ... | ... | Civil Engineering. 1934, October. |
| 13. Bradley J. N. | ... | ... | Technical Memorandum No. 471 of the Bureau of Re- clamation. |
| 14. Herbert D. J. | ... | ... | Technical Memorandum No. 384 of the Bureau of Re- clamation. |



UNIVERSITY OF ROORKEE.

With
the Vice Chancellor's
Compliments.

Approved For Release 2004/02/19 : CIA-RDP80-00926A0



25X1

THOMASON
COLLEGE OF ENGINEERING
CENTENARY
1847-1947

Approved For Release 2004/02/19 : CIA-RDP80-00926A005700070001-3

CONTENTS

| | PAGES |
|---|-------|
| 1. ADVISORY COUNCIL, 1949 | 1 |
| 2. COLLEGE STAFF, 1949 | 3 |
| 3. BOARD OF STUDIES, 1949 | 8 |
| 4. PAST PRINCIPALS | 9 |
| " ASSISTANT PRINCIPALS | 12 |
| " PROFESSORS | 15 |
| " ASSISTANT PROFESSORS | 19 |
| " LECTURERS | 20 |
| " HEAD MASTERS | 23 |
| " INSTRUCTORS | 24 |
| 5. INTRODUCTION | 25 |
| 6. HISTORY OF THE THOMASON COLLEGE OF ENGINEERING | 29 |
| 7. THE ROORKEE UNIVERSITY | 59 |
| 8. THE THOMASON COLLEGE AND THE ARMY | 62 |
| 9. PHOTOGRAPHS (<i>By Goel Photo Co., Dehra Dun.</i>) | END |

Approved For Release 2004/02/19 : CIA-RDP80-00926A005700070001-3

Approved For Release 2004/02/19 : CIA-RDP80-00926A005700070001-3

THOMASON COLLEGE OF ENGINEERING

ADVISORY COUNCIL, 1949

President :

1. KUNWAR BALBIR SINGH, I.S.E., CHIEF ENGINEER, IRRIGATION BRANCH, PUBLIC WORKS DEPARTMENT, UNITED PROVINCES.

Members :

2. Shri A. C. MUKERJI, I.S.E., CHIEF ENGINEER, BUILDINGS AND ROADS BRANCH, PUBLIC WORKS DEPARTMENT, UNITED PROVINCES.

3. Shri H. G. TRIVEDI, M.I.E. (INDIA), CHIEF ENGINEER, PUBLIC HEALTH ENGINEERING DEPARTMENT, UNITED PROVINCES.

4. Shri S. K. GHOSH, M.SC., DIRECTOR OF EDUCATION, UNITED PROVINCES.

5. Shri M. C. BIJAWAT, M.I.E. (INDIA). [REPRESENTATIVE OF THE UNITED PROVINCES BOARD OF INSTITUTION OF ENGINEERS (INDIA)].

6. Dr. N. N. GODBOLE, M.A., B.SC., PH.D. (BERLIN), REPRESENTATIVE OF UNIVERSITY EDUCATION. (NOMINATED BY THE UNITED PROVINCES GOVERNMENT.)

7. Shri DIN DAYAL SHASTRI, M.L.A., GURUKUL KANGARI, HARDWAR. (REPRESENTATIVE OF THE UNITED PROVINCES LEGISLATIVE ASSEMBLY.)

8. Acharya JUGAL KISHORE, M.L.A., ANANDPURI, GHAZIABAD. (REPRESENTATIVE OF THE UNITED PROVINCES LEGISLATIVE ASSEMBLY.)

Ex fficio Secretary

9. Shri N. CHAKRAVARTI, M.I.E.E. (LONDON), PRINCIPAL, THOMASON COLLEGE OF ENGINEERING, ROORKEE.

COLLEGE STAFF, 1949

| | | |
|---|----|--|
| Shri N. CHAKRAVARTI, M.I.E.E. (LONDON) | .. | Principal. |
| DEPARTMENT OF CIVIL ENGINEERING | | |
| Shri B. D. PURI, M.A. (CANTAB.), FORMERLY SCHOLAR, PEMBROOKE COLLEGE, CAMBRIDGE. | | Professor, Pure and Applied Mathe- matics. |
| Shri V. G. GARDE, M.SC. (ENGRG. MANCH.), M.I.E., M.ASCE., M.R. SAN. I (LONDON). | | Professor (officiating), Civil Engineering. |
| Shri S. R. SINGH, B.SC. (ENGRG. BRISTOL), A.M.I.E. | .. | Assistant Professor. |
| Shri JAI KRISHNA, B.SC., C.E. (HONS.), A.M.I.E., A.M. ASCE. | .. | Assistant Professor (officiating). |
| Shri ANAND SWARUP, M.SC. | .. | Lecturer. |
| Shri K. L. BHATTACHARYA, M.SC. (ALLI.) | .. | Lecturer. |

Shri L. S. AGARWAL, B.E., C.E., A.M.I.E. Lecturer.
Shri S. C. GOYAL, B.SC., C.E. (ROORKEE), A.M.I.E. .. Lecturer.
Shri O. P. JAIN, B.SC., C.E. (ROORKEE) Lecturer.
Shri P. B. SHAHANI, B.E. (CIVIL), A.M.I.E. Lecturer.
Shri R. M. ADVANI, B.E. (CIVIL), A.M.I.E. Lecturer.
Shri H. D. CHITALE, B.E. (CIVIL), A.M.I.E., M.R. SAN. I
(LONDON). Lecturer.

DEPARTMENT OF ELECTRICAL ENGINEERING

Shri N. CHAKRAVARTI, M.I.E.E. (LONDON) Professor.
Dr. Z. U. AHMAD, B.SC. (HONS.), D.I.C., PH.D. (ENGRG.)
(LONDON), A.M.I.E.E., A.A.M.I.E.E., ASSOC. I. MECH. E.,
M.A.S.E.E. Assistant Professor.
Shri S. N. ROY, M.SC. (MATH.), D.I.I.SC. (BANGALORE) .. Lecturer.
Shri S. RAMABHADRAN, M.A., B.SC. (HONS.), D.I.I.SC., A.I.R.E. Lecturer.
Shri J. L. JETHI, B.SC. (ENGRG.) Lecturer.

DEPARTMENT OF MECHANICAL ENGINEERING

Shri B. M. SINGH, B.SC. (ENGRG.) (B.H.U.), A.M.I., MECH. E.,
M.I.E. Professor.

Shri J. N. MOUDGILL, B.A., B.SC. (ENGRG.) (B.H.U.), TECH.,
G.M.I.S.I. A.M.I.E. Assistant Professor.

Shri JAGDAMBA PRASAD, B.SC. (MECH. & ELECT., B.H.U.), D.I.P.,
R.I.C. (GLASGOW), A.M.I.E., M.E. Lecturer.

Shri B. S. DINGWANI, B.SC. (ENGRG.) Lecturer.

Shri S. K. SOGANI, B.SC. (ENGRG.) (B.H.U.) Lecturer.

OVERSEER AND DRAUGHTSMAN SCHOOL

Shri L. I. BHATT, B.E. (CIVIL) Chief Instructor.

Shri JIWAN LAL Senior Instructor.

Shri TARA CHAND, A.M.I.E., A.M.ASCE. Senior Instructor.

Shri BHAN KUMAR JAIN Junior Instructor.

Shri REOTI NANDAN Junior Instructor.

WORKSHOP

| | | | | | |
|-------------------------|----|----|----|----|---------------------|
| Shri A. P. GHOSH, B.SC. | .. | .. | .. | .. | Superintendent. |
| Shri RAFIQ AHMAD | .. | .. | .. | .. | Instructor Foreman. |
| Shri NAND SINGH.. | .. | .. | .. | .. | Instructor Foreman. |
| Shri P. C. DUTT .. | .. | .. | .. | .. | Instructor Foreman. |
| Shri SHIV DATTA .. | .. | .. | .. | .. | Instructor Foreman. |
| Shri D. N. SAXENA | .. | .. | .. | .. | Instructor Foreman. |
| Shri PRITAM SINGH | .. | .. | .. | .. | Instructor Foreman. |

GENERAL STAFF

| | | | | | |
|--|----|----|----|----|------------------------------------|
| Shri S. K. GARG, B.SC., C.E. (ROORKEE) | .. | .. | .. | .. | Superintendent, College Estate. |
| Dr. R. S. GUPTA, M.B., B.S., P.M.S. I | .. | .. | .. | .. | College Medical Officer. |

OFFICE

| | | | | |
|--------------------------------------|----|----|----|---------------------|
| Shri K. K. SUKHIA, M.A., LL.B., L.T. | .. | .. | .. | Registrar. |
| Shri SHANTI SWARUP | .. | .. | .. | Personal Assistant. |
| Shri DHARAM NARAIN BHATNAGAR | .. | .. | .. | Accountant. |
| Shri MOHAN LAL BHARGAVA | .. | .. | .. | Head Clerk. |
| Shri Jai SINGH PUNDEER | .. | .. | .. | Stenographer. |

LIBRARY

| | | | | |
|---|----|----|----|------------|
| Shri M. I. ANSARI, B.A., DIP. (LIBRARY) | .. | .. | .. | Librarian. |
|---|----|----|----|------------|

BOARD OF STUDIES, 1949

1. Shri N. CHAKRAVARTI, M.I.E.E. (LONDON), Principal and Professor of Electrical Engineering *President*
2. Shri B. D. PURI, M.A. (CANTAB), Professor of Pure and Applied Mathematics
3. Shri B. M. SINGH, B.SC. (ENGRG. B.H.U.), A.M.I.MECH.E., M.I.E., Professor of Mechanical Engineering
4. Shri V. G. GARDE, M.SC. (ENGRG. MANCH.), M.I.E., M.ASCE., M.R. SAN. I. (LONDON), Professor of Civil Engineering
5. Shri S. R. SINGH, B.SC. (ENGRG. BRISTOL), A.M.I.E. (INDIA), Assistant Professor of Civil Engineering
6. Shri J. N. MOUDGILL, B.A., B.SC. (ENGRG.) (B.H.U.), TECH. G.M.I.S.I., A.M.I.E., Assistant Professor of Mechanical Engineering *Members.*
7. Dr. Z. U. AHMED, B.SC. (HONS.), D.I.C., PH.D. (ENGRG.) (LONDON), A.M.I.E.E., A.A.M.I.E.E., ASSOC. I. MECH. E., M.A.S.E.E., Assistant Professor of Electrical Engineering
8. Shri JAI KRISHNA, B.SC., C.E. (HONS.), A.M.I.E., A.M.ASCE., Assistant Professor of Civil Engineering

PAST PRINCIPALS

| | | | | |
|---|----|----|----|--------------------|
| 1. Genl. R. MACLAGAN, R.E. | .. | .. | .. | 1847—52 & 1856—60* |
| 2. Major OLDFIELD, R.E. (offg.) | .. | .. | .. | 1852—56 |
| 3. Col. E. C. S. WILLIAMS, R.E. | .. | .. | .. | 1860—62 |
| 4. Col. J. G. MEDLEY, R.E. | .. | .. | .. | 1863—71 |
| 5. Col. A. M. LANG, R.E. | .. | .. | .. | 1871—77 |
| 6. Major A. CUNNINGHAM, R.E. (offg.) | .. | .. | .. | 1876 |
| 7. Lt. J. H. C. HARRISON, R.E. (offg.) | .. | .. | .. | 1881—82 |
| 8. Lt. Col. A. M. BRANDRETH, R.E. | .. | .. | .. | 1877—91 |
| 9. Col. F. D. M. BROWN, V.C., I.S.C. | .. | .. | .. | 1891—92 |
| 10. Capt. E. D. BULLEN, R.E. (offg.) | .. | .. | .. | 1894, 1897—98 |
| 11. Lt. H. B. D. CAMPBELL, R.E. (offg.) | .. | .. | .. | 1898 |
| 12. Major W. A. GALE, R.E. (offg.) | .. | .. | .. | 1898 |

13. Lt.-Col. J. CLIBBORN, I.S.C., B.A. 1892—1902
14. Major-General E. H. DE V. ATKINSON, K.B.E., C.B.C.,
M.G., C.I.E., R.E. 1902—15
15. Major H. B. D. CAMPBELL, R.E. 1905
16. E. F. TIPPLe, EsQ., B.A. 1915—16
17. W. G. WOOD, EsQ., B.A. 1916—21
18. C. J. VEALE, EsQ., F.R.G.S., F.R.A.S. 1923
19. Lt.-Col. E. W. C. SANDES, D.S.O., M.C., R.E. 1921—30
20. RAJA RAM, EsQ., B.Sc., A.M.I.C.E., M.I.MUN. CY.E.,
M.R.S.I., A.M.I.E. (INDIA), C.I. (GLASGOW), A.C.P.
(LONDON.) 1932
21. MAHABIR PRASAD, EsQ., B.Sc., C.E., I.S.E. 1935
22. Dr. P. P. PHILLIPS, PH.D., F.I.C., I.E.S. 1930—32
23. H. J. AMOORE, EsQ., I.S.E. 1932—39
24. Major C. D. REID, R.E. 1939

II

25. Rai Bahadur MADAN GOPAL SARDANA, B.A., M.I.E.
(INDIA) 1940-45
26. G. LACEY, Esq., C.I.E., B.SC. (LONDON), M.I.C.E. .. 1945-46
27. Shri B. D. PURI, M.A. (CANTAB.) 1946-48

PAST ASSISTANT PRINCIPALS

| | | | | | | |
|-----|---------------------------------|----|----|----|----|----------------|
| 1. | Lt. WALKER, R.E. | .. | .. | .. | .. | 1852—56 |
| 2. | Lt. MONCKTON, R.E. | .. | .. | .. | .. | 1855 |
| 3. | Lt. G. T. CHESNEY, R.E. | .. | .. | .. | .. | 1856 & 1858—59 |
| 4. | Lt. CHAMPAIN, R.E. | .. | .. | .. | .. | 1856—57 |
| 5. | Lt. W. H. EARLE, R.A. | .. | .. | .. | .. | 1856—60 |
| 6. | Lt. JEFFERYS, R.E. | .. | .. | .. | .. | 1857—58 |
| 7. | Lt. A. M. BRANDRETH, R.E. | .. | .. | .. | .. | 1859—61 |
| 8. | Lt. J. P. WESTMORLAND, R.E. | .. | .. | .. | .. | 1860—63 |
| 9. | Lt. C. C. SCOTT MONCRIEFF, R.E. | .. | .. | .. | .. | 1861—64 |
| 10. | Lt. C. H. LUARD, R.E. | .. | .. | .. | .. | 1861—64 |
| 11. | Lt. J. BROWNE, R.E. | .. | .. | .. | .. | 1864—65 |
| 12. | Lt. L. CONWAY GORDON, R.E. | .. | .. | .. | .. | 1865—66 |
| 13. | Lt. F. FIREBRACE, R.E. | .. | .. | .. | .. | 1865—68 |

- | | | | | | |
|-----|------------------------------|----|----|----|--------------------------------|
| 14. | Capt. F. D. M. BROWN, V.C. | .. | .. | .. | 1866—68 |
| 15. | Lt. W. S. S. BISSET, R.E. | .. | .. | .. | 1868—70 |
| 16. | Lt. C. S. BEAUCHAMP, R.E. | .. | .. | .. | 1869—74 |
| 17. | Lt. R. R. PULFORD, R.E. | .. | .. | .. | 1870—73 |
| 18. | Lt. F. T. MAXWELL, R.E. | .. | .. | .. | 1876 |
| 19. | Lt. M. G. GREGSON, R.E. | .. | .. | .. | 1873—77 |
| 20. | Lt. S. M. MAYCOCK, R.E. | .. | .. | .. | 1874—78 & 1879— 81 |
| 21. | Capt. A. CUNNINGHAM, R.E. | .. | .. | .. | 1864—65 & 1870 —80. |
| 22. | Capt. G. C. ONSLOW, R.E. | .. | .. | .. | 1877, 1878, 1880 & 1881—86. |
| 23. | Capt. E. BLUNT, R.E. | .. | .. | .. | 1882, 1883—84 & 1887—89 |
| 24. | Capt. R. V. PHILLPOTTS, R.E. | .. | .. | .. | 1882 & 1887—89 |

- | | | | |
|---------------------------------------|----|----|---|
| 25. Major J. H. C. HARRISON, R.E... | .. | .. | 1877—79, 1881—83, 1884—87 & 1890— 93. |
| 26. Lt. R. F. G. BOND, R.E. | .. | .. | 1894—95 |
| 27. Lt. H. L. CROSTHWAIT, R.E., B.A. | .. | .. | 1893—96 |
| 28. Capt. E. D. BULLEN, R.E., B.A. | .. | .. | 1889—97 |
| 29. Lt. H. B. D. CAMPBELL | .. | .. | 1895 & 1896—97 |
| 30. Capt. E. D. BULLEN, R.E., B.A. | .. | .. | 1897—98 |
| 31. Lt. E. L. HARCATTLE, R.A. (offg.) | .. | .. | 1898 |
| 32. Lt. H. B. D. CAMPBELL, R.E. | .. | .. | 1897 |

PAST PROFESSORS

| | | | | | |
|---|----|----|----|----|--|
| 1. W. SCOTLAND, ESQ. | .. | .. | .. | .. | 1848—76 |
| 2. H. B. MEDLICOTT, ESQ., F.G.S. | .. | .. | .. | .. | 1855—62 |
| 3. MURRY THOMASON, ESQ., M.D., F.R.S.E. | .. | .. | .. | .. | 1864—71, 1872—78, 1879—83 & 1884—88. |
| 4. J. ELLIOT, ESQ., M.A. | .. | .. | .. | .. | 1869—72 |
| 5. Lt. C. S. BEAUCHAMP, R.E. (offg.) | .. | .. | .. | .. | 1871 |
| 6. Capt. A. CUNNINGHAM, R.E. | .. | .. | .. | .. | 1872—75 |
| 7. G. T. SPARKE, ESQ. | .. | .. | .. | .. | 1876—90 & 1891. |
| 8. Lt. S. M. MAYCOCK, R.E. (offg.) | .. | .. | .. | .. | 1878—79 |
| 9. Lt. G. C. ONSLOW, R.E. (offg.) | .. | .. | .. | .. | 1882 |
| 10. Capt. J. H. C. HARRISON, R.E. (offg.) | .. | .. | .. | .. | 1885 |
| 11. Sub-Cond. J. O'NEILL (offg.) | .. | .. | .. | .. | 1890 |
| 12. E. F. TIPPLe, ESQ., B.A. | .. | .. | .. | .. | 1897 |

| | | | | |
|-----|---|----|----|---------|
| 13. | F.W. SEDGWICK, ESQ., B.A., A.INST.E.E. | .. | .. | 1897 |
| 14. | Sergt. C. BOLTON (offg.) | .. | .. | 1898—99 |
| 15. | Lt.W. H. BAHBURY, R.E. | .. | .. | 1900 |
| 16. | Major H. B. D. CAMPBELL, R.E. | .. | .. | 1901—10 |
| 17. | Lt. F. R. H. EUSTACE, R.E. | .. | .. | 1903—10 |
| 18. | Lt. T. H. L. SPAIGHT, R.E. | .. | .. | 1908 |
| 19. | E. F. TIPPLe, ESQ., B.A. | .. | .. | 1901—18 |
| 20. | F.W. SEDGWICK, ESQ., M.A., A.M.I.C.E., M.I.E.E. | .. | .. | 1901—19 |
| 21. | Lt. D. K. EDGAR, R.E. | .. | .. | 1905—07 |
| 22. | J. C. EVANS, ESQ. | .. | .. | 1906 |
| 23. | Dr. P. P. PHILLIPS, PH.D., F.C.S. | .. | .. | 1905—32 |
| 24. | Lt.-Col. E.W. C. SANDES, D.S.O., M.C., R.E. | .. | .. | 1910—30 |
| 25. | C. J. VEALE, ESQ. | .. | .. | 1908—12 |
| 26. | H. P. JORDON, ESQ., M.SC. | .. | .. | 1911—22 |

27. Rai Bahadur VENI MADHAV MUKERJI, B.A. .. 1912—20
28. G. LACEY, ESQ., C.I.E., B.SC., A.C.G.I., M.I.C.E. .. 1916—17, 1928—31
& 1945—46
29. G. T. ANTHONY, ESQ., I.S.E. 1918—19
30. W. L. STAMPE, ESQ. 1921—24
31. J. M. SALUSBURY TRALAWNTY, ESQ. 1922
32. SHIVA NARAYAN, ESQ., M.A., M.SC., A.M.I.MEC.E.,
A.M.I.E.E. 1923
33. P. L. DHAWAN, ESQ., I.R.S.E. 1923
34. RAJA RAM, ESQ., B.SC., A.M.I.C.E., M.I.MUM. CY.E.,
A.M.I.E., C.T., A.C.D. 1923—33, 1937—38
35. L. E. DAWSON, ESQ., I.S.E. 1924—25
36. R. A. BRADSHAW SMITH, ESQ., B.SC., A.M.I.C.E. .. 1926—27
37. SALIG RAM, ESQ., B.A., I.S.E. 1927
38. MOHSIN ALI ESQ., B.A., M.SC., I.S.E. 1928—30

| | | | | | |
|-----|---|----|----|----|---------|
| 39. | Dr. M. A. HAMID, PH.D. | .. | .. | .. | 1931 |
| 40. | M. L. GARG, ESQ. | .. | .. | .. | 1932—33 |
| 41. | Rai Bahadur D. D. MAL, I.S.E. | .. | .. | .. | 1933—34 |
| 42. | MAHABIR PRASAD, ESQ., S.SC., I.S.E. | .. | .. | .. | 1935—36 |
| 43. | W. M. G. DAWSON, ESQ., I.S.E. | .. | .. | .. | 1935—36 |
| 44. | K. N. KATHPALIA, ESQ., I.S.E. | .. | .. | .. | 1936 |
| 45. | Major H. WILLIAMS, R.E. | .. | .. | .. | 1936—38 |
| 46. | ROMESH CHANDRA, ESQ., I.S.E. | .. | .. | .. | 1937—38 |
| 47. | Major C. D. REID | .. | .. | .. | 1938—39 |
| 48. | Rai Bahadur M. C. BIJAWAT, B.A., I.S.E. | .. | .. | .. | 1939—45 |

PAST ASSISTANT PROFESSORS

1. W. D. McLAREN, Esq., A.M.I.E.E., A.M.I.E.MECH.E. .. (Lecturer in 1915—
21)
(Assistant Professor
1922—26)
2. H. T. CUMMING, Esq., A.M.I.E. (INDIA) 1922—23
3. N. CHUCKERBUTTY, Esq., L.C.E. 1923
4. Major A. M. McLEAN, M.C., A.M.I.MECH.E. .. 1927—33
5. Capt. J. CRAWFORD, A.M.I.MECH.E. Assistant Professor
1935—40
6. P. L. SHARMA, Esq., G.D.ARCH., A.R.I., B.A., A.I.A.A. .. Assistant Professor
1945—46

PAST LECTURERS

| | | | | | |
|-----|---|----|----|----|------------------|
| 1. | J. S. GURNEY, F.S.I., M.R.S.I. | .. | .. | .. | 1912—28 |
| 2. | Mr. W. D. McLEAN, A.M.I.MECH.E., A.M.E.E. | .. | .. | .. | 1914—22 |
| 3. | Major A. H. McLEAN, M.C., A.M.I.MECH.E. | .. | .. | .. | 1914—15, 1922—26 |
| 4. | Mr. W. H. TIPP | .. | .. | .. | 1922 |
| 5. | Mr. J. CRAWFORD, A.M.I.MECH.E. | .. | .. | .. | 1922—23 |
| 6. | Mr. P. CHAKERVARTI, M.SC., M.A., A.M.I.E. | .. | .. | .. | 1922—39 |
| 7. | Mr. P. C. SEN GUPTA, B.SC. | .. | .. | .. | 1922—35, 1943—49 |
| 8. | Mr. F. J. SMITH | .. | .. | .. | 1922—29 |
| 9. | Mr. H. T. CUMMING, A.M.I.E. (INDIA) | .. | .. | .. | 1922—30 |
| 10. | Mr. M. L. MISRA, A.M.I.E. (INDIA) | .. | .. | .. | 1922—38 |
| 11. | Mr. C. E. RAVINE | .. | .. | .. | 1922—23 |
| 12. | Mr. DHANPAL CHANDRA | .. | .. | .. | 1927—29 |

13. Mr. P. L. SHARMA, G.D.ARCH. (BOM.), F.R.I.B.A., A.I.A.A.,
M.R.S.I., M.I.E.E. 1929-45
14. Mr. B. L. SHARMA, B.SC., A.M.I.E.E. 1929-39
15. Mr. S.R. SINGH, B.SC. (BRISTOL) 1931-45
16. Mr. P. S. BHATNAGAR.. .. . 1934-38
17. Mr. Z. U. AHMAD, B.SC., PH.D., A.M.I.E.E... .. . 1939-43
18. Mr. JAI KRISHNA, B.SC., C.E. 1939-40, 1941-45
19. Mr. C. P. MITAL 1940
20. Mr. S. K. GUPTA 1942
21. Mr. K. S. MISRA, C.E. (ROORKEE) 1943-49
22. Mr. N.R. SITAPATTI 1943-45
23. Mr. RAMESHWAR SARAN, B.SC., C.E. (HONS.) 1944-45
24. Mr. M. S. JAIN 1944-48
25. Mr. R. L. AGARWAL, C.E. 1945-48
26. Mr. S. K. AGARWAL, C.E. 1945-47

| | | | | | |
|-----|--------------------------|----|----|----|---------|
| 27. | Mr. NIRANJAN LAL .. | .. | .. | .. | 1945 |
| 28. | Mr. P. S. YOGA, C.E. .. | .. | .. | .. | 1946-47 |
| 29. | Mr. RAVI DUTT, C.E. .. | .. | .. | .. | 1947 |
| 30. | Mr. O. D. SHARMA .. | .. | .. | .. | 1947 |
| 31. | Shri J. R. PHANSALKAR .. | .. | .. | .. | 1947-49 |
| 32. | Shri P. S. AGARWAL .. | .. | .. | .. | 1947 |
| 33. | Shri R. P. SHINGHAL .. | .. | .. | .. | 1947-48 |

PAST HEAD MASTERS (*Overseer Class*)

1. Sardar NATHA SINGH 1922—28
2. Mr. J. S. GURNEY, F.S.I., M.R.S.I. 1928—30
3. Mr. H. T. CUMMING, A.M.I.E. (INDIA) 1930—33
4. Mr. J. CRAWFORD, A.M.I.MECH.E. 1933—35
5. Mr. P. C. SEN GUPTA, B.SC. 1935—43

PAST INSTRUCTORS

| | | | | | | |
|----|---------------------|----|----|----|----|---------|
| 1. | Mr. RAM SAHAI | .. | .. | .. | .. | 1922—32 |
| 2. | Mr. PRITAM DAS | .. | .. | .. | .. | 1922—32 |
| 3. | Mr. PHUNNAN RAM | .. | .. | .. | .. | 1922—37 |
| 4. | Mr. ABDUS SATTAR | .. | .. | .. | .. | 1922—32 |
| 5. | Mr. RAGHUNANDAN LAL | .. | .. | .. | .. | 1922—29 |
| 6. | Mr. JIWAN LAL | .. | .. | .. | .. | 1933—43 |

THOMASON COLLEGE OF ENGINEERING
"FOUNDED IN 1847"

The Thomason College of Engineering is a State college near the Ganga Canal in the town of Roorkee in the United Provinces. The nucleus of the College was founded in 1845 by Lt. Richard Baird Smith of the Bengal Engineers who started to train some young Indians at Saharanpur in Civil Engineering. The altitude of the town is 880.6 feet above sea level. The campus of the College covers an area of 365 acres comprising of the main College building, the subsidiary buildings, residential buildings for teaching staff and students, playgrounds, gardens and pasture land.

The main building is in the renaissance style with stately pillars, dome and a quadrangle and comprises of three spacious vestibules, seven large halls used as class-rooms and library besides the main Convocation Hall. There are five lecture theatres and about 50 other rooms of fairly spacious size used for smaller classes, staff rooms and offices. In the subsidiary buildings there are two lecture theatres and about eight other class-rooms.

The main Library of the College is one of the best equipped in the country and contains valuable books in General Engineering, Mathematics, Philosophy, Religion, Social Science, Physiology, Pure Science, Useful Arts, Fine Arts, Literature, History and Fiction. The number of volumes in the Library exceeds forty-five thousand.

The College is equipped with a Photo-Litho Printing Press of the Government of the United Provinces, and the Meteorological Department of the Government of India have also a second-class observatory under the charge of the College. The College also undertakes the repairs and tests of survey instruments. The repair shops are well known for their fine and accurate workmanship.

Instructional work is organized in Civil, Electrical and Mechanical Engineering up to the Degree standard. The Degree course is of three years' duration and the intake per year is 60. In addition there are also classes for training overseers (sub-engineers) and in draughtsmanship which are of two years' duration and the intakes each year are of 80 and 20 respectively. Admission to all these classes is by two competitive examinations, one for the degree classes and the other for the remaining two, and each year about 700 students appear in each of these examinations. The minimum age-limit is 17 and the maximum 21.

Instruction is imparted through lectures, tutorials, class tests and practical classes. The degree courses are common in the earlier stage, after which the three branches are separated for specialized training. In addition to these classes the students have to undergo every year field training in survey lasting for three weeks, when each student works independently with his own instrument. Each year the students are sent out on engineering tours in charge of teachers and on return they have to submit a technical report of the works visited. The progress of each student from the date of his admission is watched and marks are allotted

for his work in the tutorials, class tests, survey field work, games, military training, conduct and discipline. Marks thus allotted are added to the aggregate.

Each year the session commences from 16th October. The working hours are from 8 a.m. to 12.30 p.m. in the morning when lectures and tutorial classes are held, and in the afternoon from 1.30 to 3.30 p.m. for practical classes.

The playgrounds are extensive and cover a large area. In addition there is a swimming pool and each year a regatta is held. Every student has to take part in at least two games and learn swimming and marks are allotted for proficiency in these, which again are added to the aggregate. The National Cadet Corps Organization supervise the military training of the Engineering students and all students who are physically fit to undergo this training. The remaining students attend the physical training class each morning.

“The Thomasonian Society” is run by the students and in its meetings students read and discuss articles on technical and other subjects. Lectures by outside persons are also arranged on varied subjects for the benefit of the students. There is a students’ “Dramatic Society” which provides opportunities for self-expression and artistic creation by the students. The Lion magazine, which is the authorized students’ magazine, is edited and published by the students every quarter. It contains articles of technical character as well as of general interest.

The College runs a co-operative stores and a dairy for the benefit of the students and staff. There is a small hospital under a qualified medical officer who takes care of the health of the students. Besides these, there are bakery, sweets' tailors' and shoemakers' shops.

The Thomason College of Engineering was originally founded as a Civil Engineering College and in the year 1946 departments of Electrical and Mechanical Engineering were added as need was felt for them. The institution has grown to its present dimensions through hard work, strict discipline and constant realization of the actual needs of the country. It has created a tradition which inspires and illuminates its alumni and has carved out a name for itself in the engineering field in India and outside. The students passing out of its portals are holding the highest positions throughout India and outside, so much so that in has been attracting students of engineering from Africa, Persia, Burma, Sikkim, Ceylon and Indonesia.

The Thomason College after over a century of steady progress and achievements is now being raised to the status of an Engineering University to widen its field of activities and to provide greater scope for higher studies and research work. The aim of the institution has been to train practical engineers and inculcate in the minds of the students the dignity of labour, a keen sense of discipline, strong character, high ideals and worthy purposes.

HISTORY OF THE THOMASON COLLEGE OF ENGINEERING

ROORKEE, the site chosen for the foundation of the famous institution described in these paragraphs, would appear to have been an apt selection. With the Himalayas in the far background with their perpetual snow, and across a broad plain from the Lower Siwalik Hills nearer at hand, the town of Roorkee is set in a tract of country where the great Ganga River appears in its early swift course after the torrents down the hill slopes have gathered into a voluminous stream to speed on their journey to the wide plains of the United Provinces. Symbolically, therefore, Roorkee could fitly house a college where training would be imparted to generations to come in the science, and even the art, of harnessing natural resources to the service of man.

Realistically, economic and various engineering reasons made the establishment of a Civil Engineering educational institution at Roorkee a certainty. There was the immediate need for engineer officers and subordinates for the Ganga Canal and to it were added other requirements. The Western and Eastern Yamuna Canals, not very far from Roorkee, which had originated back in 1817 and 1822, respectively, needed improvement and repairs in Dehra Dun, Rohilkhand, and the area around Delhi, extensive works for drainage and irrigation requiring skilled supervision were in hand or under contemplation. The roads from Jubbulpore to Mirzapur, and the Grand Trunk

Roads from Calcutta to Delhi and from Agra to Bombay, were being constructed and large buildings were rising in many important centres. The Land Revenue Settlement Survey had just been completed. So there had arisen a large demand for skilled civil engineering execution and control in many directions. To meet this demand, officers of the Army, British Non-Commissioned Officers, and soldiers, and Indian man-power were available but they all required proper training in engineering theory and practice, and, for the foreigners, also a fair knowledge of the local languages and peculiarities of Indian materials and methods of work.

In the year 1845 Lt. Richard Baird Smith of the Bengal Engineers, then Superintendent of the Eastern Yamuna Canal, had started to train some young Indians at Saharanpur in Civil Engineering, and in 1846 Lieutenant-Colonel (afterwards Col. Sir Proby) Cautley of the Bengal Army, the famous designer and builder of the Ganga Canal, suggested to the Hon'ble James Thomason, Lt. Governor of the then North-West Province, the idea of founding an Engineering College proper at Roorkee. In 1847, after the First Sikh War, and eleven years after the first line of the Ganga Canal had been taken, Lord Hardinge, the Governor General of India, decided on the vigorous prosecution of the Ganga Canal Scheme, a project which was beset with great engineering difficulties, specially in the first few miles of its course where works of enormous size were required to carry the canal under, through, or over the natural drainage of the country. With a view to supplying the skilled industry and resource which the construction of a scheme of this magni-

tude and difficulty required, and to secure an adequate staff of well-trained engineers to look after it on its completion, the need for the institution of an Engineering College at Roorkee became more immediate.

Roorkee offered special technical advantages. Mr. James Thomason pointed out that the location of a College near the Solani Aqueduct on the Ganga Canal would afford peculiar facilities for instruction in Civil Engineering, while the large Canal Foundry Workshops, started by Major Allen of the Bengal Army, and other important structures were also in course of construction where students would later be able to obtain practical instruction. A Library and a Model Room were available. All these facilities frequently collected, at the place, groups of scientific and experienced officers, contact with whom would prove of benefit to engineering students.

The above proposal for a State Engineering College met with cordial support from the Governor General of India, and on October 19, 1847, a small College was opened with Lt. Robert MacLagan of the Bengal Engineers as the Principal, to be assisted by a Head Master, a Drawing Master and two Indian teachers. The prospectus issued on November 25, 1847, provided for three departments in the College. The first department was for training civilians as Sub-Assistant Civil Engineers. It was laid down that candidates must be under 22 years of age, able to read and write English easily, and have the necessary knowledge of Mathematics. The number to be admitted to this class was to be eight every year. The second department was for training European Non-Commissioned Officers

and soldiers for appointment as Overseers in the Public Works Department. They were required to pass an elementary test in reading, writing, drawing and easy mathematics before admission. The number of admissions to this class was limited to ten per year. The third department was for training young Indians in Surveying, Levelling and Plan Drawing. Candidates were required to have some knowledge of arithmetic and to be able to read and write Urdu. Admissions to this class were limited to sixteen every year. Annual examinations would be held for all classes and those who successfully completed the course of instruction would receive certificates of proficiency.

The first batch of students was admitted on January 1, 1848, by the transfer of a few young Indians who were being instructed by Major W. E. Baker of the Bengal Engineers, who was officiating at the time for Col. Cautley as Director of the Ganga Canal. These men apparently joined the third department. In August, 1848, a batch of ten Non-Commissioned Officers and soldiers joined the second department. No building was available then, and work began and continued in tents until a very small building, the forerunner of the present College, was constructed, consisting of two class-rooms (26' x 32'), an office (20' x 23'), a hall of the same size, four small verandah rooms (16' x 12') with verandahs on all sides. The staff and the students moved into this building about the winter of 1848. The opening session of the College was interrupted by the outbreak of the Second Sikh War when Lt. MacLagan and his soldier students had to be away on field service for about two months.

In 1850 the annual number of military students in the Second Department was raised to 15, and on April 7, 1851, there were 50 students of all classes receiving instruction in the College. Forty-two men had already passed out into Government service.

The year 1851 was one of fresh impetus to the development of the College. The Commission appointed to enquire into the superintendence and execution of public works in Bengal at the commencement of this year had recognized the valuable service which the Roorkee College had already rendered to the Public Works Department of the Government, had mentioned with approval the level of instruction it had imparted to its students, and had appreciated the advantages of the situation and surroundings of the College for a high standard of practical training. At the end of the Second Sikh War, with the accretion of additional territory to the Government, increased undertakings of canals and roads became a necessity. To meet the needs of the anticipated increase Mr. Thomason prepared a scheme for the expansion of the College. Posterity owes it to the memory of James Thomason to recover from oblivion the words which he recorded on the occasion in the first page of his pamphlet, dated October 3, 1851, in introducing the new scheme. He said:

"This pamphlet was compiled by myself, and much of the information it contains was drawn from private sources. The completion of the plan, which is here sketched out, may perhaps devolve on others, and I am desirous that some record should remain of the data on which I founded my conclusions. In this interleaved copy will be found references to the private notes and other sources from which the materials were drawn."

Simla, October 3rd, 1851.

J. THOMASON,

The enthusiasm of a pioneer still breathes life into these restrained words penned a hundred years ago.

The main features of Mr. Thomason's expansion scheme were :

1. Admission of officers both of the Royal and East India Company's services to study at Roorkee in a class to be called "The Senior Department."
2. The superintendence and improvement of the village schools around Roorkee to work as feeders for the third or the Indian Department of the College.
3. The establishment of a depot for mathematical and scientific instruments and of a workshop for their repair and manufacture.
4. The formation of a Museum of Economic Geology.
5. The erection of an Observatory for instruction.
6. The maintenance of metal and stone printing presses with a book-binders' establishment and all necessaries for the publication of scientific works with appropriate drawings and illustrations.
7. The enlargement of the College buildings and establishment to meet all these purposes.
8. The doubling of the number of students in the second and the third departments.

Here is a plan which bears eloquent testimony to the grasp of a creative mind. Germs can be detected in it which could have led to many developments on modern lines of engineering in later years. Thomason "reminded the Government that they had embarked with all their energies on the noble work of improving the condition of the people, and developing the resources of the country. A commencement had been made, and it would be impossible to draw back without damage to the national character and without sacrifice to both income and power."

The design of the new College was entrusted to Lieutenant George Price of the First Bengal Fusiliers who was working those days on the Ganga Canal and later became the Chief Engineer, Hyderabad. The exact date of commencement of the construction of the new College is not known, but it seems that the work was started in the year 1852 under the supervision of Lieutenant Price. The present impressive edifice in the Renaissance style stands to the credit of the vision and design of that junior infantry officer.

By 1854 the construction of the College and its associated buildings was well advanced and it was completed some time in January, 1856, when the buildings were brought into use. The building, as completed at that time, had only covered corridors where the Library and Convocation Hall exist today. The rear of the quadrangle was open except for a small model room and museum block in the centre. As time went on, the building was enlarged according to requirements. The Library and the Convocation Hall were built in 1873 and the Science Department were added at the rear of the College in 1896.

Until the year 1854 the Institution was known as the "Roorkee College," but in that year the Directors of the East India Company instituted a scholarship to be called "Thomason Scholarship" and the Governor General decreed that the College should be known as the "Thomason College of Civil Engineering" as an "enduring memorial of the eminent merits and services of Mr. Thomason."

In 1855 the public works in India which had hitherto been carried out under the orders of the "Military Board" were taken over by the Department of Public Works which was organized as a Civil Department, and after the construction of the College buildings was over in 1856, a Committee was appointed by the Lieutenant Governor to enquire into the past working and present condition of the College and to prepare a scheme for extensions and improvements to meet the demands of the Services. The recommendations of this Committee, most of which received the assent of the Governor General in November, 1857, could not be put into effect immediately owing to the interruptions of the historical "War of Independence" of 1857 and only the important changes mentioned below were carried out during the next two years:

1. A date was fixed for admission to the Senior Department and the number of seats was fixed at 16.
2. *First Department*—The non-stipendiary students were termed "The English Class" with ten seats. The stipendiary students were termed "The Native Class."

3. *Second Department*—This had two classes:
 - (a) *Military Class*—The seats in this class were 30 with a course of only one year as against two in the other Departments.
 - (b) *Non-Military Class*—Indian students were now allowed in this class.
4. *Third Department—Vernacular*—Some alterations in the syllabus and the requirement of a knowledge of English were prescribed for this Department.
5. An Evening Class for Indian workmen in Drawing, Geometry, and Estimating was started.
6. A Professor of Surveying, who was also to be Curator of the Instruments Depot, and a Professor of Practical Chemistry and Photography, were added to the staff.
7. A College Museum was started which contained many models from England.
8. An Observatory was sanctioned.
9. A Gymnasium was sanctioned.
10. The Press was reorganized and enlarged.
11. Young officers and Non-Commissioned Officers and privates of the Sappers stationed at Roorkee were required to attend the College as far as their duties permitted.

12. Gardens and grounds were neatly laid out and improved.

Colonel R. E. MacLagan, R.E., the first Principal, retired in 1860, and was succeeded by Capt. E. C. S. Williams, R.E., who in turn was followed by Major J. G. Medley, R.E., in 1863 who continued in office up to the year 1870. The principal changes made during these years were :

In 1864 a third years' course was sanctioned for the Senior and First Departments, unless a higher certificate was gained in two years. Eight students were guaranteed appointments as Assistant Engineers, and practically all the students of the Senior Department who passed out were provided for. The students of the Second Department still remained at College for one year. All who qualified received appointments in the Public Works Department, the Military students in the first grade, the English Civilians in the first or second grade according to their ages, and the Indians in the third grade.

In 1866 a Mistri (or Mechanic) Class was formed. These students received a stipend of Rs.5 a month, and on passing out, an appointment on Rs.25 a month as Head Artisans. In this year an Officer's Surveying Class was also formed. These officers were admitted without any entrance examination, and took instruction for seven months, in Military Surveying, Drawing, and Field Engineering. On passing out they received certificates qualifying them for the Quarter-Master General's Department.

In 1868 a Military Class was started in the Third Department as a tentative measure. The students in the Third Department remained at College for two years.

In 1870 the nomenclature of the classes was changed to the present one. The Senior Department became the Engineer Class, Military and Civil. The Second Department became the Upper Subordinate Class, and the Third Department became the Lower Subordinate Class.

By 1870, the number of students had risen to 231, and the names of the various classes had been altered. The Senior Department became "The Engineer Class" while the Second Department the "Upper Subordinate Class" and the Third Department the "Lower Subordinate Class."

In 1870 the staff consisted of a Principal, two Assistant Principals, a Professor of Experimental Science, and a Professor of Drawing. These officers were assisted by a staff of masters for the Upper Subordinate Class under a Head Master, and another staff for the Lower Subordinate Class.

In 1871, Major A. M. Lang, R.E., took over from Col. J. G. Medley, R.E., as Principal and in the following year the Upper Subordinate Class course, which till then was of one year's duration, was extended to two years. In 1873, the Central Instruments Depot which was located in the College was transferred to the Canal Foundry and Workshops

and a new class for instruction of men of the Guides Corps in Surveying and Drawing was started. By now the engineering profession had become popular amongst the educated Indians as was shown by the fact that between 1873 and 1875 sixteen Indians passed out of the Civil Engineer Class while during all the first twenty-six years of its existence only seven-teen Indians had passed out.

The history of the Thomason College, since its establishment, may be said to be divided into four periods, and the year 1875 marked the close of the first period. This period was characterised by the pecuniary aid given by Government to most students in the form of stipends. It was an era of pioneering in an untrodden country, and Government had, naturally, to bear the cost. But it was also a period of great industrial development and of great activity in the construction of railways, canals, roads and other aids to industrial enterprise. The public mind was opening to the benefits of public works and to the advantages of engineering as a profession. The result was that in 1875 Government found it possible to restrict the financial help previously given to students and to limit the number of guaranteed appointments to the Public Service.

The years 1875 to 1896 constitute the second period during which, though the pecuniary aid to students was to a large extent done away with, most of the students paid practically nothing for their education. The training, however, was limited to Civil Engineering, Surveying and allied subjects. Technical or industrial classes did not exist.

An examination fee of Rs. 20 for the Engineer Class was for the first time introduced in 1876, and the number of guaranteed appointments was reduced to eight. The effect of the Cooper's Hill College, which was started in 1871, now began to be felt, and the number of candidates for admission to the Engineer Class, which was 55 in 1876, fell to 20 in 1878.

In 1878 Major Brandreth took over the duties of Principal. In 1881 the Guides Corps Class was thrown open to the whole Indian Army, and was called the Native Military Survey Class. In this year also, for the first time, marks were allotted for physical fitness and for proficiency in athletics.

From the commencement of the year 1882 the entire financial responsibility for the College was thrown on the local Government. The Secretary of State ordered that no Europeans, except Royal Engineers, were to be appointed as engineers in India and they would be recruited from the Cooper's Hill College. Indians were to be given all vacancies in the Public Works Department, irrespective of the position they held after the final examination. European competitors would only receive appointments for which Indians were unable to qualify. In 1885 the Military Section of the Lower Subordinate Class was abolished and all the vacancies were thrown open to civil personnel. In 1886 the Professorship in Experimental Science was abolished and considerable reductions were made in the staff due to an anticipated reduction in strength of the Engineer Class. In 1888 the British Military Survey Class was formed on the same lines as the Indian Military Survey Class.

In 1891 Col. Brandreth retired and was succeeded as Principal by Col. Browne, v.c. He retired in 1892, Major Clibborn succeeding.

In 1894 the last band of men passed out of Roorkee College into the Imperial Service and the Provincial Service was formed. All men from the Engineer Class entered the Provincial Service from 1894.

The years 1896 to 1920 may be considered as the third period of the development of the College. It was reorganized in 1896 to the effect that all students thenceforward, except soldiers, would pay fees for their education in it. This extension of the commercial principle, far from injuriously affecting the College, has added to its efficiency and activity. The number of applicants for admission began to exceed the number of seats available and it became necessary to insist on a process of selection whereby only those who stood highest in a competitive admission examination could be admitted. From this time onward, the College did not concern itself only with the education of engineers and their subordinates but its scope was extended to include industrial and technical education generally, the aim being to develop the College into a technical institute for the Province, which should control, stimulate and inspire technical training of all types.

The administration of the College was transferred from the control of the Public Works Department to that of the Education Department, thus emphasizing the fact that the College was not only intended as a nursery for recruits to the Public Works Department,

but also to supply the need for technical education for the Province in general. A Committee of Management was appointed and the College was attached to the Allahabad University.

Educational qualifying tests were brought into force in 1895. In 1896 the first revised entrance examination, applicable to both English and Indian students, was held.

The course of study in the Engineer Class was extended from two to three years and in addition the students of this class were required to take a year's apprentice training in the Public Works Department as "Engineer Students" before they could be appointed as Assistant Engineers.

A class was formed for Mechanical apprentices, having a three years' practical course in the Workshops combined with theoretical education.

An industrial class was started having a three years' course, divided into 15 sections, including press work, photography, photo-mechanical processes and art-handicrafts. Students could take up one or more of these sections according to their capabilities. In 1897, two Professors, two Instructors and a Demonstrator were appointed to the staff, i.e. a Professor of Mathematics, a Professor of Experimental Science, an Instructor in Applied Science, a Technical Instructor and a Laboratory Demonstrator. A Chemical Laboratory was started and new Technical Workshops were sanctioned.

In 1899 an Electrical Engineer Class was started and the new Technical workshops, equipped with the latest machinery run by electricity, were built at a total cost of Rs. 33,000. The applied Science laboratories were also equipped and a Physical and Mechanical Laboratory were provided. The College Press was remodelled and enlarged. An electricity-operated water-supply system for the College area was installed.

Before the above alterations and additions, envisaged in the reorganization scheme of 1896, could be completed, Col. J. Clibborn, C.I.E., I.S.C., proceeded on leave preparatory to retirement in 1901, and Capt. E. H. de V. Atkinson, R.E., took over as Principal and continued till 1915. A Council was created in 1901 to assist the Principal in regulating the courses of study and other matters which were recognized as outside the province of the Committee of Management. A Sub-Committee of this Council, known as the Board of Studies, still performs these duties, though the Council itself has ceased to exist. The extent of the expansion of the Thomason College between the years 1896 and 1900 may be judged from the facts that the number of classes increased from 8 to 25; the number of students from 185 to 324, the fees from Rs.1,421 to Rs.6,784 and yet the yearly expenditure of the management dropped from Rs.1,48,261 to Rs.1,32,064. Though Sir A. P. MacDonnel, Lieutenant Governor, while quoting these figures in a speech at Roorkee in November, 1900, had stressed that it was the object of Government to develop the Thomason College into a technical institute for the North-West Provinces, to control, stimulate and inspire technical teaching of all kinds, experience showed later that advanced technical

education could not be carried on at Roorkee except at the cost of higher instruction in Civil Engineering, as the College, with its 25 classes, had already become unwieldy.

In 1902, Capt. Atkinson reformed the internal working of the College. The session was divided into three terms, with an examination at the end of each. Each branch of study was placed under a Professor with assistants who were responsible for the teaching of that branch throughout the Course. In 1903 a dairy was started. A number of much needed buildings such as stores, a central power house, etc., were constructed. In 1905 a start was also made to equip a Mechanics Laboratory for the practical teaching of Mechanics. A Survey Class for Indian officers of the Imperial Service Troops was held for the first time. The Mechanical Apprentice Class which had been started in 1896 was placed on a more practical basis; entrance examinations were introduced and the course was altered to one of three years at the College and two years as apprentice in outside workshops. The rules for the Draftsman and Computer Class were altered and an examination in Drawing was held for men who had passed the Lower Subordinate Class entrance examination but had failed to obtain vacancies. An Instructor in Chemistry was appointed in 1905 and also a Professor of Drawing and Surveying and a Demonstrator in Chemistry.

On April 8, 1905, His Excellency the Viceroy, Lord Curzon, visited the Thomason College, and on March 7, 1906, the College was honoured by a brief visit from Her Royal Highness, the Princess of Wales (later Her Majesty Queen Mary), who afterwards

presented portraits of His Royal Highness, the Prince of Wales, and herself to the College. The Lieutenant Governor—Sir J. J. D. LaTouche—visited the College during 1905.

In the year 1907, a large scheme for further development of the College as a technical institute was sanctioned. The Lieutenant Governor at the time—Sir John Hewett—was greatly interested in industrial and technical education. An electric light and fan system was installed in the College main building, the workshops and the Principal's residence. New engines of ample power were installed. A technical class was started and the Mechanical Apprentice Class enlarged. To meet these expansions additional hostel accommodation was built, the workshops doubled in size, new class rooms built, additional staff entertained, a new water supply inaugurated and new laboratories costing Rs.94,000 were sanctioned. In 1908 an Automobile Driving Class was started and good progress was made in training drivers. The British and Indian Military Classes were removed from the College. In 1909 new laboratories and rooms for the Photo-Mechanical Department were completed and the ground near Malikpur village taken up for future use. In 1910 the Technical Class was abolished and arrangements were made to form a Department of Technology. An elaborate textile machine was installed in the College Workshops and an expert Instructor was placed in charge of the Cotton Class. The College furnished a court at the Allahabad Industrial Exhibition of 1911. In this year the Department of Technology was formed to consist of:

(1) a higher division,

- (2) a lower division (Mechanical Apprentice Class), and
- (3) an Automobile Driver Class.

In 1911-12 the Automobile Driving Class was transferred to Lucknow which marked the beginning of the gradual removal of technical and industrial classes from the Thomason College on its reversion from a technical institute to a purely Civil Engineering institution. Admissions to the Textile Class ceased and in 1915 the higher division of the Department of Technology was abolished and the lower division, the Mechanical Apprentice Class, was transferred to Lucknow.

When the World War I commenced in August, 1914, many members of the staff volunteered for active service in the War. Instruction was hampered. Funds became scarce, and all large-scale expansions had to be postponed to better times.

A Board of Industries was formed for the United Provinces and the College Committee of Management was reorganized as a sub-committee of the Board.

The declaration of the Armistice was duly celebrated in November, 1918, and the College settled down to consolidate its position in the difficult times which followed the War.

In 1919, a complete reorganization scheme for the staff of the Thomason College was drawn up by the Committee of Management to suit the new requirements of the Government under the Reforms Scheme and a new policy was laid down for the future of the College.

It was submitted to the Secretary of State. Certain modifications to this scheme were proposed in May, 1920, and final sanction to the amended scheme was accorded by the Secretary of State on January 29, 1922. Admissions to the Upper Subordinate, Lower Subordinate, Industrial Apprentice and Mechanical and Electrical Engineer Classes were stopped, as it had been decided finally that the training of Mechanical and Electrical students was not suited to Roorkee. Hence to replace the Upper Subordinate and Lower Subordinate Classes a scheme was prepared for a new Overseer Class of Intermediate standard.

In the year 1921, the College Committee of Management was replaced by the Advisory Council constituted by Government. The status of the Thomason College improved by the Government of India offering to the Civil Engineer Class nine and ten vacancies in alternate years in the Indian Service of Engineers as guaranteed appointments. This step by which employment in the Imperial Service was again thrown open to highly qualified students, was a return to the practice in vogue up to 1894, when students could pass into that Service. In October, 1921, Mr. W. G. Wood, C.S.I., was succeeded by Major E. W. C. Sandes, D.S.O., M.C., R.E., as Principal.

In October, 1922, the first Overseer Class was started with 40 seats and a three years' course which was later reduced to one of two years. The former Lower Subordinate Class staff was transferred to the Overseer Class. Later, assistance was also given by the Lecturers of the Civil Engineer Class.

In 1922 a Committee was appointed by Government to inspect the College Press with a view to effecting possible economies through the transfer of the control of the Press to the Superintendent of the Government Press, Allahabad. Though the Committee recommended the transfer, the Advisory Council was against this move and Government accepted the opinion of the Council. The benefits of the reorganization scheme were felt in this year. All members of the staff were allowed rent-free quarters from October, 1922, and salaries were improved. In November, 1923, sanction was accorded to the formation of a platoon of the 3rd (Allahabad) Battalion of the University Training Corps (Indian Territorial Force) at Roorkee, thus enabling the Indian students of the Thomason College to undergo military training for the first time. Applications for enrolment far exceeded the number of vacancies available in a platoon, and practically only one-half of the Civil Engineer Class students could be enrolled. The remainder, as well as the Overseer Class students, continued to receive instruction in Physical Drill.

In 1924, a special committee was set up by Government to investigate certain matters connected with the syllabuses, courses of study and the staff of the College, arising out of the introduction of the reorganization scheme of 1919. A very comprehensive report was submitted by this Committee in 1925 which was dealt with item by item by the Advisory Council, on whose recommendations Government sanctioned several useful alterations and innovations in the College courses. An extension of the Indian Engineer Class Club was put in hand as also several internal alterations in the College buildings and hostels.

A very fine steel model of a plate girder bridge on a large scale was presented to the College by Messrs. Burn & Co., Howrah, which was installed in one of the College model rooms.

In April, 1928, the College was honoured by the visit of His Excellency the Viceroy, Lord Irwin, which was the first visit of a Viceroy to the College after that of Lord Curzon in 1905. The Civil Engineer Class students passing out in July, 1928, were the first batch after many years to whom the Government of India guaranteed no appointments in the Indian Service of Engineers, such guarantee having been withdrawn in the case of students entering in October, 1925, and thereafter. In 1928 the qualifying standard for the entrance examination to the Civil Engineer Class was raised from the Matriculation to the Intermediate or its equivalent. Electric supply was obtained in this year from the Bahadurabad Power Station for use in the College Estate. The new water-supply system could not be installed for want of funds. A very large steel model road-bridge of the Baltimore Truss type with overhead bracing was presented in 1927 by Messrs. Burn & Co., Howrah, and was placed in the College model room.

During 1928-29, the separate department of Electrical Engineering and Physics was abolished and the instruction in Electrical Engineering transferred to the Mechanical and Electrical Section at the Workshops. Physics was combined with the work of the Chemistry Department which henceforth came to be known as the Department of Applied Science.

In 1929-30, Col. Sandes retired and Dr. P. P. Phillips, PH.D., F.I.C., I.E.S., became Principal.

The Photo-Mechanical and Litho Department and Book Depot ceased to be departments of the College from March 1, 1932, and the course of instruction in Photography was abolished.

Dr. Phillips retired in March, 1932, and Mr. Raja Ram, Professor of Civil Engineering, succeeded him.

A Retrenchment Committee was appointed by Government under the presidentship of the Hon'ble Mr. J. P. Srivastava, Minister for Education, United Provinces, and on its recommendations many reductions were made in 1932. The Departments in the Civil Engineering Course were reduced from five to three, the Department of Applied Science was abolished, Physics was added to the Department of Mathematics and Chemistry and Geology to the Department of Civil Engineering. The Department of Survey and Drawing was amalgamated with the Department of Civil Engineering and its Professorship reduced to an Assistant Professorship. Further, the Principal, in addition to his ordinary duties, became the head of the Department of Civil Engineering and was called upon to give lectures to the classes.

Mr. H. J. Amore, I.S.E., became Principal in October, 1932.

In accordance with arrangements made by the Army Headquarters, India, with the Government of the United Provinces, three Indian commissioned officers from the Indian Military Academy were to be admitted annually to the Civil Engineer Class starting from

October, 1935, for training in Engineering with a view to their obtaining commissions in the Indian Engineers. A military officer, Major H. Williams, R.E. (now Major-General Williams, Engineer-in-Chief, Ministry of Defence), was also deputed by the Army Headquarters to be in-charge of these Indian commissioned officers and to work as Professor of Civil Engineering. This arrangement was a short-lived one and was terminated in 1939 by the Defence Department.

Mr. Amore retired in 1939 and Mr. B. D. Puri, M.A. (CANTAB.), Professor of Mathematics, became the next Principal. Rai Bahadur Mool Chand Bijawat shortly followed Professor Puri and then Rai Bahadur Madan Gopal Sardana, B.A., M.I.E. (INDIA), retired Superintending Engineer, P. W. D., I. B., took over charge as Principal from Rai Bahadur Mool Chand Bijawat in January, 1940.

A Reorganization Committee was appointed by the United Provinces Government in 1939 under the chairmanship of the late Raja Jwala Prasad (retired Chief Engineer of the United Provinces and then Pro-Vice-Chancellor of the Banaras Hindu University) to inquire generally into the organization of the College and to submit proposals for improving its efficiency. This Committee recommended, besides various improvements in the internal working of the College, that the College should be developed as a centre of training in all branches of Engineering, like Civil, Electrical, Mechanical, Aeronautical, Wireless, Chemical, Military and Automobile Engineering. It also recommended the inclusion of

Photography, Aerial Photography, Explosives, Industrial Psychology, Engineering Economics and Architecture in the course of studies of the Civil Engineer Class. This Committee was further of the view that, instead of being affiliated to any University, the College should be immediately converted into a statutory and autonomous technical University and the medium of instruction should be Hindustani.

A move was made in 1940 by the Defence Department of the Government of India to take over the Thomason College for giving Engineering training to Army Officers and artisans for recruitment to the Royal Indian Engineers. The United Provinces Government offered to accommodate the proposed "School and Military Engineering" in the Thomason College but did not agree to part with the College altogether and thus lose the Civil Engineering training. This was not acceptable to the Defence Department and hence the proposal was dropped at that time.

In 1940, an officer of the Engineer-in-Chief's Branch visited the College to make arrangements for the training of British non-commissioned officers and War Technicians which was started in 1941 and the College was made a Civil Military Centre with a strength of 650 War Technicians.

The United Provinces Government guaranteed appointments in the Provincial Service of Engineers for two students of the Civil Engineer Class starting with the batch passing out in July, 1941. This number of guaranteed appointments was later increased to four.

In 1943 it was also decided by the Government that in order to meet the increased demand for Overseers and Engineers in all branches of the Public Works Department, the Civil Engineering Course be decreased from 3 to 2 years as a war measure and the number of students in each of the Civil Engineer and Overseer Classes should be increased by 10. These extra 20 students had to fill a bond to join the Military Engineering Service on passing out from the College. This decision was given effect to immediately and consequently the College opened on September 1, instead of October 15, as was usual.

The training of the British non-commissioned officers and War technicians which was started in 1941 was concluded on April 15, 1943, and from May to November, 1943, the first technical unit of the Civil Pioneer Force received its training at the College. The matter of establishing a School of Military Engineering at Roorkee was revived by the Government of India in 1943. At a meeting which was held at Government House, Lucknow, on August 27, it was decided that, as a war measure, military and civil training should go on side by side in the College and that the military authorities should receive all facilities in the way of lecture rooms, laboratories, workshops, hostel accommodation, etc., for the instruction of the military personnel. As a result of this, the School of Military Engineering was established at this College on September 24, 1943. All available accommodation was placed at their disposal, but they required much more as the School progressed very rapidly. Additions were made to the College Workshops, many new buildings were constructed by the military authorities and a large extent of residential accommodation was

also made available to them. In fact, the whole face of the College Estate was changed within a short time. As now the Civil Pioneer Force could not be given training in the College Workshops side by side with the School of Military Engineering, this unit was transferred to Madras on November 22, and all temporary accommodation provided for them was taken over by the School of Military Engineering. There had been very close co-operation in every way between the Thomason College of Engineering and the School of Military Engineering, and the scheme for training both military and civil personnel side by side went on smoothly.

Another contribution of the College to the war effort was the taking over of the Survey Instrument repair work of the Public Works Department of the United Provinces and the Punjab by the Survey Department of the College in 1943. This was due to the Mathematical Instruments Office, Calcutta, getting busy with war work of its own. Under the Officer-in-Charge of its Survey Department, the College has been doing this work of repairs of survey instruments creditably.

In 1945, the posts of Lecturers in Drawing and Surveying were raised to those of Assistant Professor of Drawing and Architecture and Assistant Professor of Surveying, respectively.

In 1945, Mr. G. Lacey, B.Sc., C.I.E., M.I.C.E., became the Principal. He was followed again by Mr. Puri in 1946.

After the close of World War II the School of Military Engineering was to leave Roorkee, within two years of the conclusion of the Armistice and it eventually left in October, 1947, for its new home at Poona.

Beginning with the session 1946-47, the duration of the course in the Civil Engineer Class was again restored to three years and the first batch under the restored scheme passed out in 1948.

Another important Reorganization Committee was appointed in December, 1945, under the chairmanship of Professor Cecil L. Fortescue, Head of the Electrical Engineering Department, Imperial College of Science and Technology, London "to examine the working of the Thomason College of Civil Engineering in all its aspects and make recommendations with a view to reorganize it on a basis that will make it more useful to the Province, more efficient and more up to date."

This Committee submitted its report on February 12, 1946. The present Ministry which had since come into office accepted the Committee's report practically in its entirety. As a result, teaching in Electrical and Mechanical Engineering was started in the College, and under an order, dated October 28, 1946, Government have renamed the College as "The Thomason College of Engineering" to make the name comprehensive to cover other types of Engineering besides Civil Engineering. Another notable change that was

introduced with effect from the session of 1946/47 has been that women students have been allowed to join the College through the usual competitive entrance examination.

At last, thanks to the enthusiasm and constructive vision of the United Provinces Government, there have materialized the two boldest measures in the development of the College, namely, first, its expansion under the Fortescue Committee's recommendations to provide teaching up to the Degree standard in Electrical and Mechanical Engineering in addition to Civil Engineering, besides other subjects to follow, for example, Chemical Engineering; and second, the change of the Institution into a University to provide all the advancement which that status connotes. The reorganization following the Fortescue Committee's report and constitution of the University have been dealt with more fully later. Here it may be mentioned that with the support and encouragement of the United Provinces Government, the Building Research Unit of the Council of Scientific and Industrial Research has been housed at the College and the Irrigation Research Section of the Public Works Department, United Provinces, has also been located at Roorkee. These steps are expected to prove of mutual benefit to both the Department and the University. As a result of these activities the number of students in the College has already doubled and is likely to increase considerably in a few years when the other courses up to the Degree standard are introduced in the curricula of the College.

It should also be stated here that the United Provinces Government have very readily come to the assistance of the East Punjab Government by finding room for the students

and staff of the erstwhile MacLagan College of Engineering and Technology at Moghalpura who were uprooted and whose studies had suffered due to the disturbed political conditions on the eve of the partition on August 15, 1947. The Roorkee College has placed at the disposal of the East Punjab College sufficient accommodation both for tutorial and residential purposes and has allowed them the use of its workshops and laboratories, etc.

Shri N. Chakravarti, M.I.E.E. (LONDON), Superintending Engineer (Hydro-Electric), Irrigation Branch, United Provinces, succeeded Shri Puri as Principal in 1948 and has continued in office.

As the Thomason College of Engineering, Roorkee, with its one century of life enters on a new era of progress with its transformation into an Engineering University, unique in the history of technical education in India, the country may well acknowledge its debt to what the Institution has done for it and congratulate it on its shining record of progress. For the future the auguries are bright and Roorkee College can be trusted to fulfil its splendid promise in the realms of higher technical education and the lofty sphere of engineering research.

THE ROORKEE UNIVERSITY

The reorganization schemes from time to time which have led the Thomason College of Engineering to its present stage of expansion under the Fortescue Committee's recommendations and have brought it to the status of a University have been traced in the previous section. It will also have been seen that the genesis of the idea underlying the Fortescue Report and the decision to raise the College to the position of a University could be detected in the Raja Jwala Prasad Reorganization Committee's Report of 1939.

When the Fortescue Committee's Report actually came out in February, 1946, the Government devoted considerable thought to the matter and decided to convert the College into a University. This has since been statutorily implemented by passing the Roorkee University Act. Teaching at the College has been going on now on the lines of expansion laid down in the Act, and Degrees will be awarded for the first time in the first Convocation of the University, to be held along with the Centenary, to the first graduates in Electrical and Mechanical Engineering and to Civil Engineering graduates who received Diplomas hitherto. The Draughtsman's Class with a two years' course has also been introduced from 1948.

The status of the Roorkee College has not been raised to that of a University as a matter of mere prestige. It ensures the recognition, both in the country and abroad, of the final seal of approval which the College sets on the work of its students as degrees in Engineering at par with similar degrees in the rest of the world. It helps to broaden the basis, and to

raise the level, of instruction, not only in subjects primarily connected with Civil Engineering, but also in Electrical and Mechanical Engineering, subjects which are essential and indispensable to engineering knowledge and practice today. To ensure fully efficient instruction in all the branches of engineering to be taught in the Roorkee University, steps are being taken to re-equip and reorganize the existing laboratories and to instal additional ones as necessary. Plans are being prepared for the following laboratories:

- (i) Hydraulics.
- (ii) Soil Engineering.
- (iii) Reinforced Concrete.
- (iv) Structural Engineering.
- (v) Heat Engines.
- (vi) Internal Combustion Engines.
- (vii) Testing of Materials.
- (viii) Refrigeration.
- (ix) Hydraulic Machine.
- (x) Advanced Electrical Machines.
- (xi) Electrical Communications.
- (xii) Electrical High Voltage.

These expanded laboratory facilities will also promote work in research which is to be one more of the primary concerns of the University. As may have appeared from the

earlier mention, a step in this direction has already been taken by housing at the Roorkee College the Building Research Unit of the Council of Scientific and Industrial Research. This, when completed, will provide an organization on a nationwide scale to take up a programme of a study of materials, traditional and new, acoustics of buildings, exclusion of noise and ventilation and damp, a study of foundations or "Soil Mechanics," and will provide technical assistance in one form or other to those engaged in the building industry, for example, architects, builders, contractors, etc. The scope of this research is large and in its status of a University the Institution at Roorkee will become with facility a co-ordinating centre of high level research in this line. The Irrigation Research Station of the Public Works Department, United Provinces, also referred to before, is situated not far from the College and it is expected that the University of Roorkee will also integrate in its work basic research in irrigation in collaboration with the Research Station of the Public Works Irrigation Department.

With the institution of the various additional courses of study the number of students in the University will increase and create a more developed and comprehensive corporate life to the benefit of future Indian citizenship. Hopes are entertained that the University of Roorkee, thus functioning on a vast scale, will not only become the leading centre of technical and technological education in India but one of the premier institutions of the East for the highest standards of scientific and technical proficiency.

THE THOMASON COLLEGE AND THE ARMY

No Engineering College in India has maintained so close and consistent a connection with the Army as the Thomason College. When it was founded the Public Works Department was largely staffed by the Army officers and as a result many of its early students were soldiers. The majority of its Principals had been Army Engineers, and during the greater part of its existence there have been military classes of some form or other under its control. When Auxiliary and Officer Training Units were authorized, the College formed units from among its students, and since the College and the headquarters of the Bengal Group, Royal Indian Engineers, comprise practically the whole of Roorkee there has always been plenty of contact between these two great institutions.

The Principals have on the whole been a distinguished body of men and if their careers are a guide it would appear that they were carefully selected.

Many of the students too have been soldiers.

Classes for non-commissioned officers and soldiers were also formed when the College was first started and continued for a much longer period than those for officers. As late as 1923 there was a "Military Class" at the College which trained soldiers of all Arms as "Upper subordinates" for the Military Engineer Service. In World War II similar classes were again organized for a number of years. In 1873 a class for Surveying and Drawing was started for soldiers of the Guides Corps and in 1881 this class was thrown open to men from all units of the Indian Army. These classes continued up till World

War I, and many of the men who qualified at them entered the Survey of India. Indeed during the century of its existence, there has seldom been a time when there was not some form of military classes in the College.

In 1943 it became essential to establish a central training establishment for engineer officers of the Army in India. Time did not permit of the construction of lecture rooms, laboratories, workshops and living accommodation on the scale required, but the problem was solved by Army Headquarters turning once again to the College. The Government of the United Provinces agreed to place a considerable part of the College at the disposal of the School of Military Engineering and to assist it in every possible way. Thus from 1943 till 1947 the School worked side by side with the College, and to the College belongs the honour of having housed and helped the first Indian School of Military Engineering in the early days of its existence.

There has naturally been much close and friendly co-operation between the College and the Sappers and Miners. Many a student has made his first real acquaintance with Field Engineering under the guidance of a young Sapper Officer or Non-Commissioned Officer, and many an officer remembers gratefully much help and hospitality from the College. The "Olympic" matches have been keenly contested yearly and no College Regatta is complete without a Pontoon Race or Sports without an Army Relay Race. The nature of the connection changes, but it is safe to predict that the College will always maintain, as it has in the past century, this connection with the Army.

Approved For Release 2004/02/19 : CIA-RDP80-00926A005700070001-3

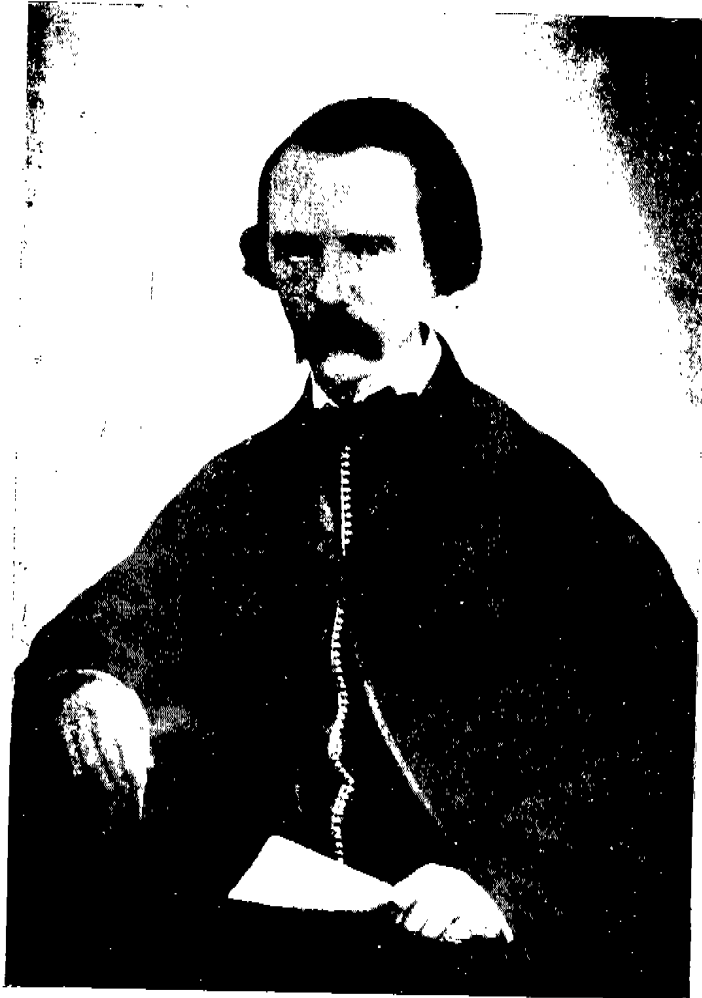

GENERAL R. MACLAGAN, R.F.

Approved For Release 2004/02/19 : CIA-RDP80-00926A005700070001-3

Approved For Release 2004/02/19 : CIA-RDP80-00926A005700070001-3

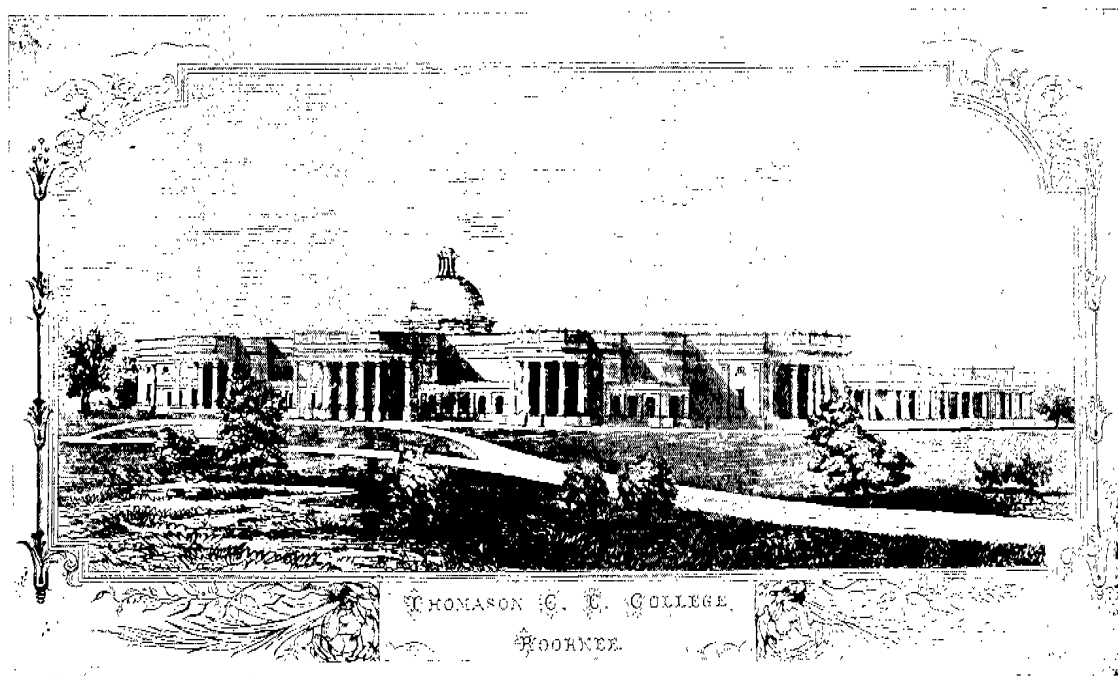

(FROM A PRINT OF AN OLD WOODCUT)
1861

Approved For Release 2004/02/19 : CIA-RDP80-00926A005700070001-3

Approved For Release 2004/02/19 : CIA-RDP80-00926A005700070001-3



VIEW OF THE COLLEGE LAWNS

Approved For Release 2004/02/19 : CIA-RDP80-00926A005700070001-3

Approved For Release 2004/02/19 : CIA-RDP80-00926A005700070001-3



COLLEGE QUADRANGLE



CORRIDOR

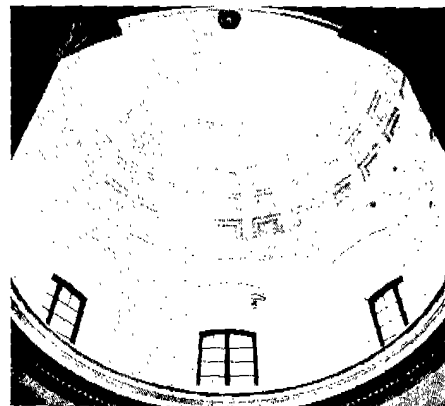

DOME
(INTERIOR VIEW)

Approved For Release 2004/02/19 : CIA-RDP80-00926A005700070001-3

Approved For Release 2004/02/19 : CIA-RDP80-00926A005700070001-3



PLAN OF THE COLLEGE ESTATE

Approved For Release 2004/02/19 : CIA-RDP80-00926A005700070001-3

Approved For Release 2004/02/19 : CIA-RDP80-00926A005700070001-3

THOMSON CIVIL ENGINEERING COLLEGE,
ROORKEE.

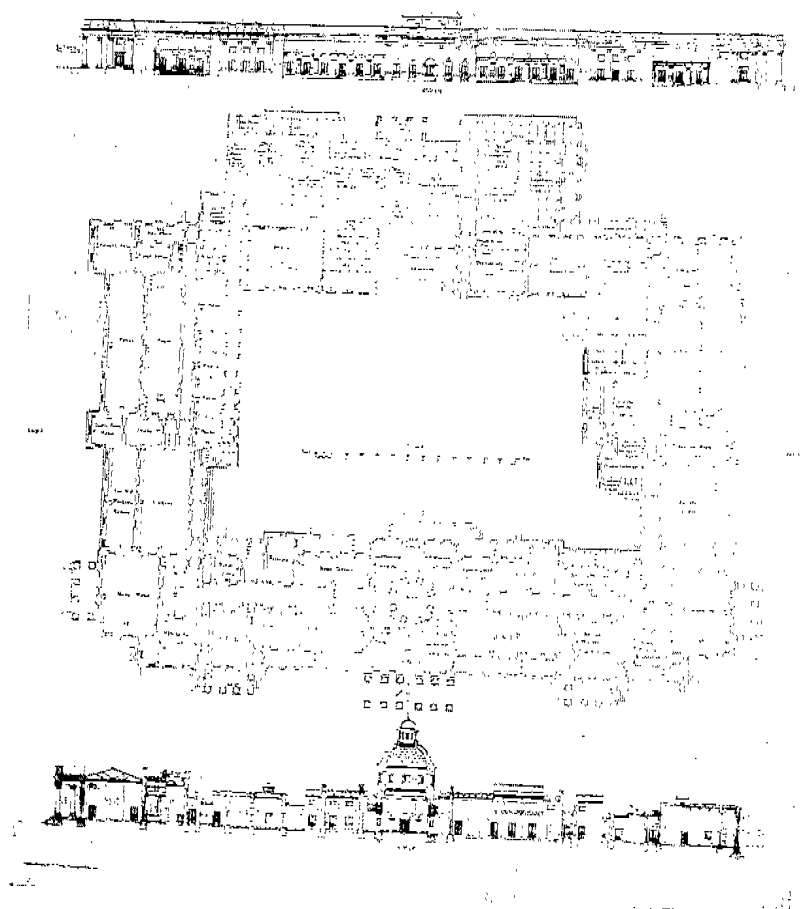

Approved For Release 2004/02/19 : CIA-RDP80-00926A005700070001-3

Approved For Release 2004/02/19 : CIA-RDP80-00926A005700070001-3



A CORNER OF THE COLLEGE LIBRARY

REINFORCED CONCRETE
MUSEUM

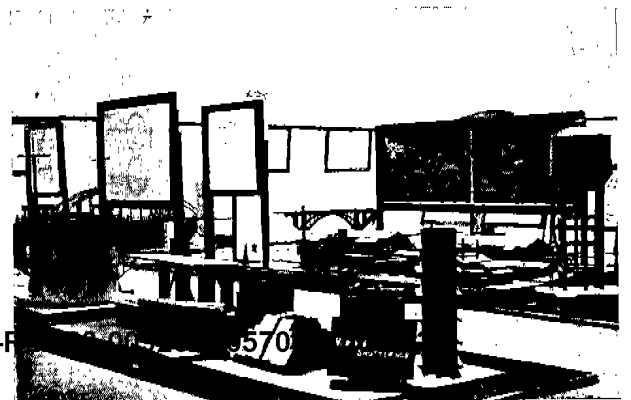

Approved For Release 2004/02/19 : CIA-RDP80-00926A005700070001-3

Approved For Release 2004/02/19 : CIA-RDP80-00926A005700070001-3

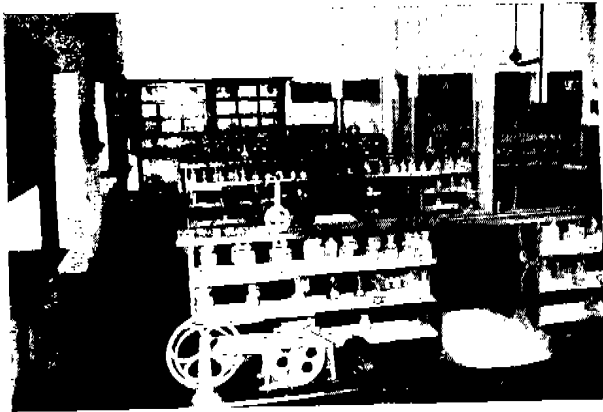

CHEMICAL LABORATORY

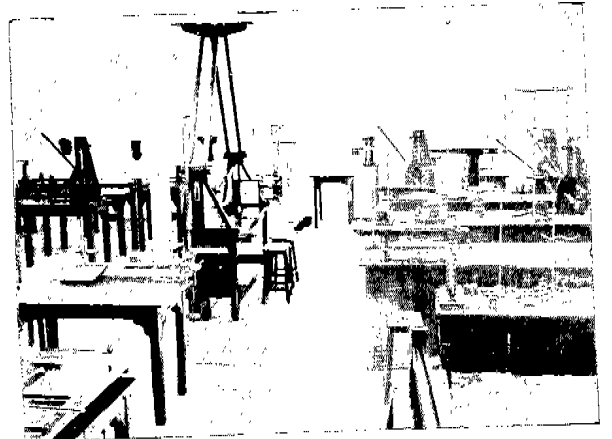

MECHANICS LABORATORY

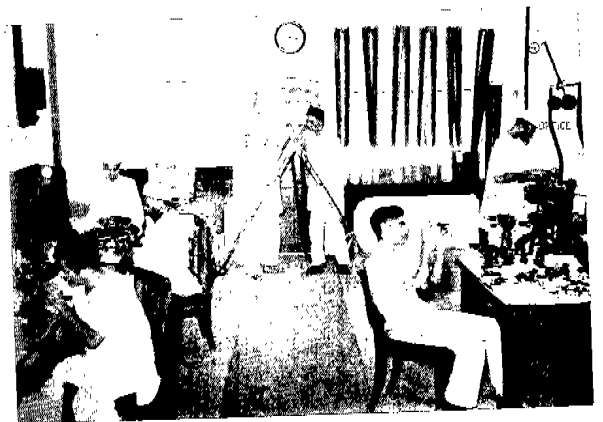
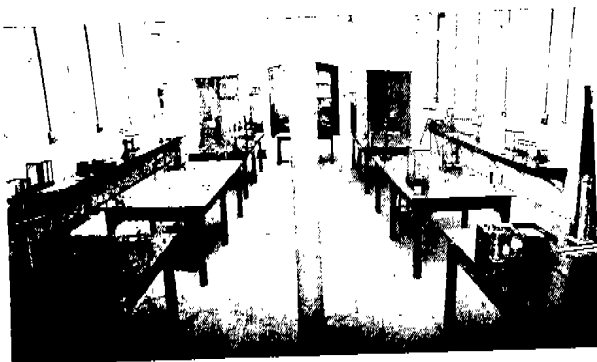

SURVEY INSTRUMENT REPAIR

Approved For Release 2004/02/19 : CIA-RDP80-00926A005700070001-3

Approved For Release 2004/02/19 : CIA-RDP80-00926A005700070001-3

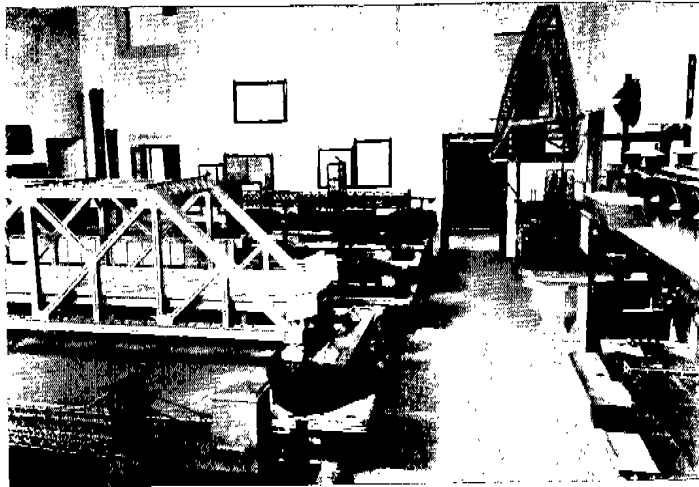

MODEL ROOM



HYDRAULICS LABORATORY

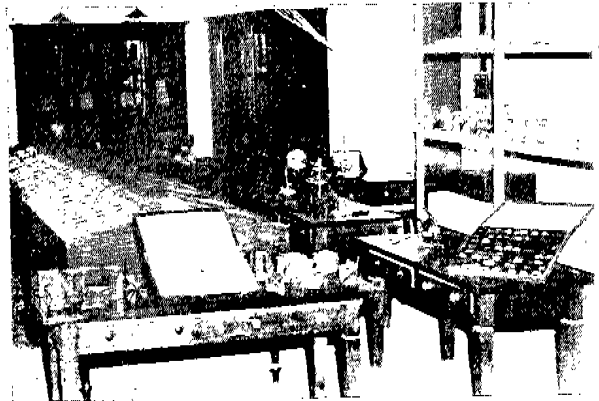

GEOLOGICAL LABORATORY AND
MUSEUM

Approved For Release 2004/02/19 : CIA-RDP80-00926A005700070001-3

Approved For Release 2004/02/19 : CIA-RDP80-00926A005700070001-3

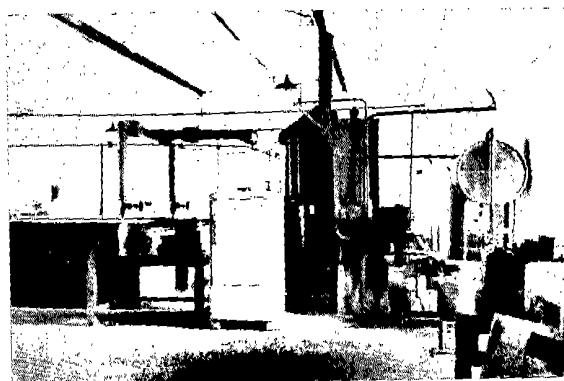

REFRIGERATION LABORATORY

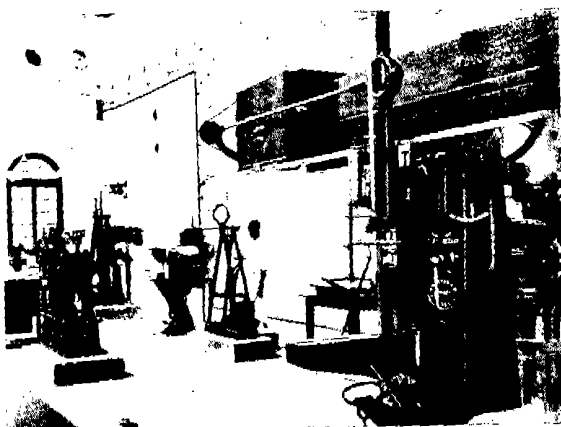

TESTING LABORATORY

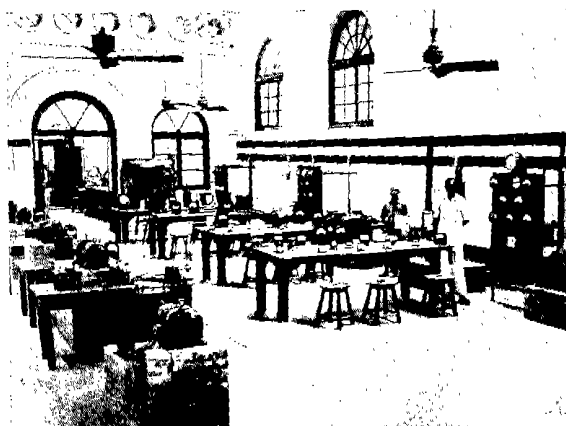

JUNIOR ELECTRICAL LABORATORY

Approved For Release 2004/02/19 : CIA-RDP80-00926A005700070001-3

A 02) CIA-RDP80-00926A005700070001-3

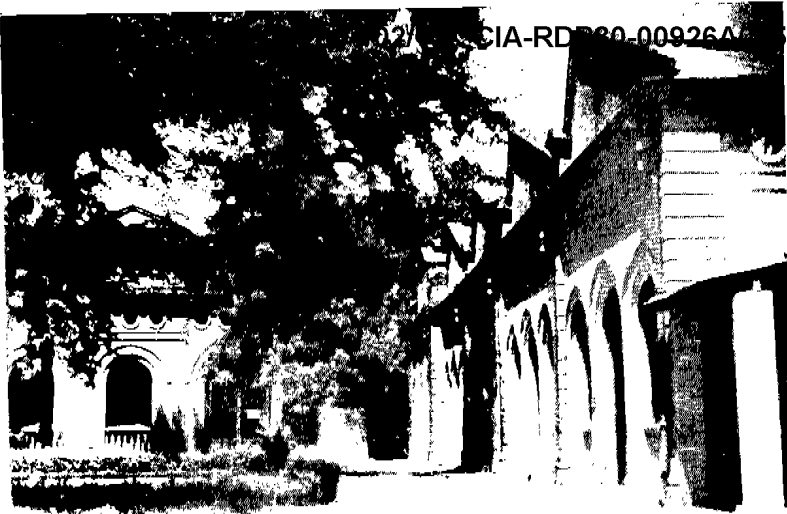

COLLEGE WORKSHOPS (side view)



Approved For Release 2004/02/19 : CIA-RDP80-00926A005700070001-3

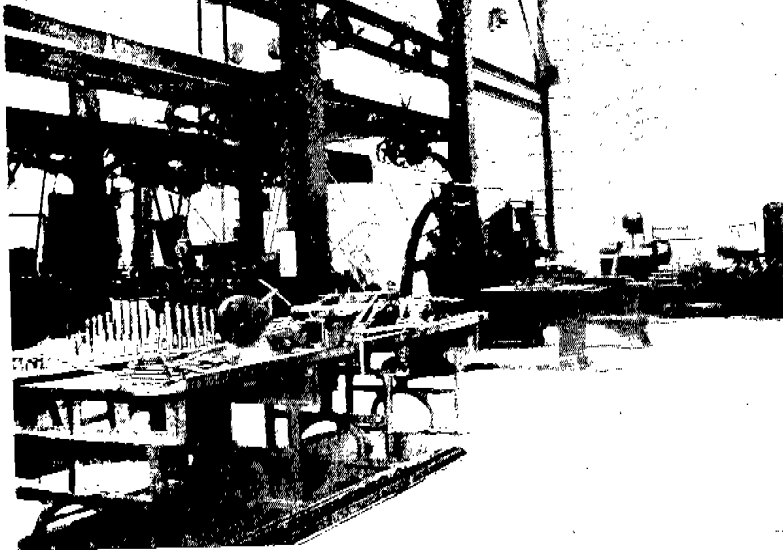

MACHINE SHOP



Approved For Release 2004/02/19 : CIA-RDP80-00926A005700070001-3

FOUNDRY

Approved For Release 2004/02/19 : CIA-RDP80-00926A005700070001-3

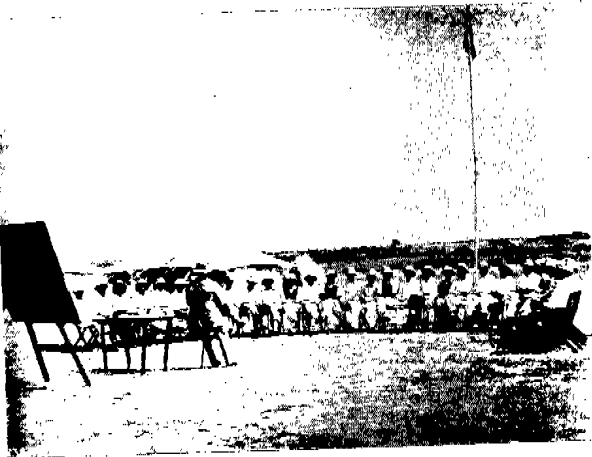

OPEN AIR CLASS



THEODOLITE OBSERVATION



Approved For Release 2004/02/19 : CIA-RDP80-00926A005700070001-3
TRIANGULATION CAMP

Approved For Release 2004/02/19 : CIA-RDP80-00926A005700070001-3



CAMP



ROUND OF ANGLES

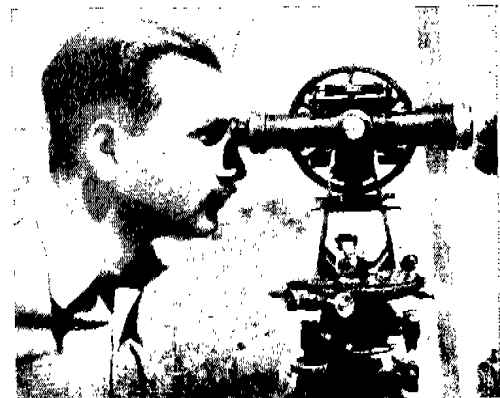

THEODOLITE OBSERVATION

S. M. E. OFFICERS AT FIELD WORK

Approved For Release 2004/02/19 : CIA-RDP80-00926A005700070001-3

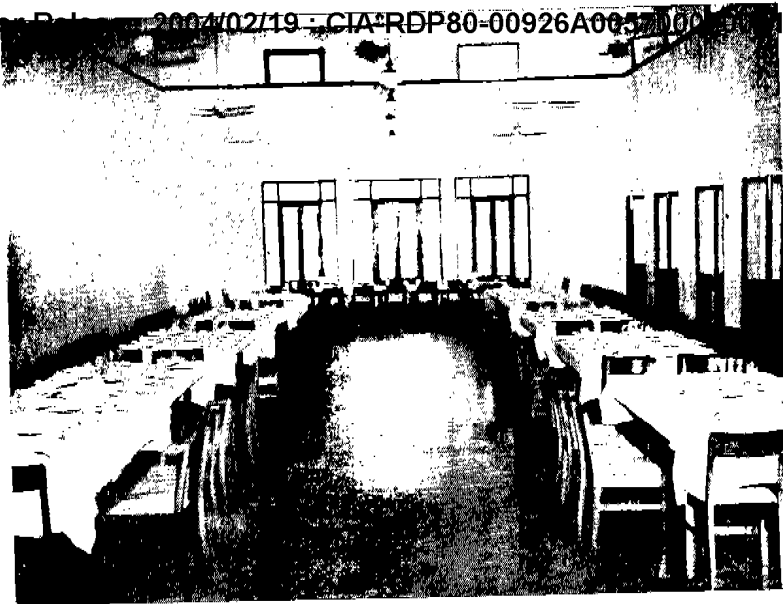

ENGINEER STUDENTS' DINING HALL

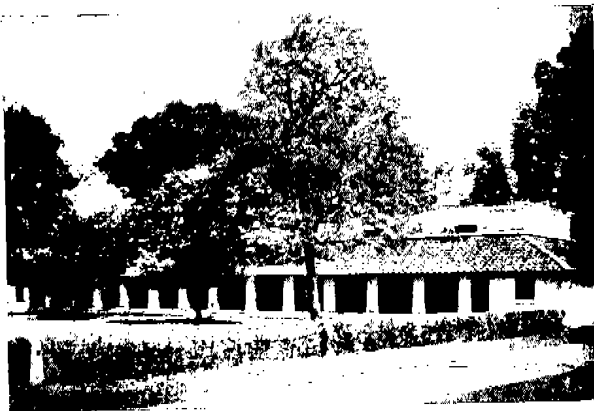

Approved For Release 2004/02/19 : CIA-RDP80-00926A00570001-3

ENGINEER STUDENTS' HOSTEL

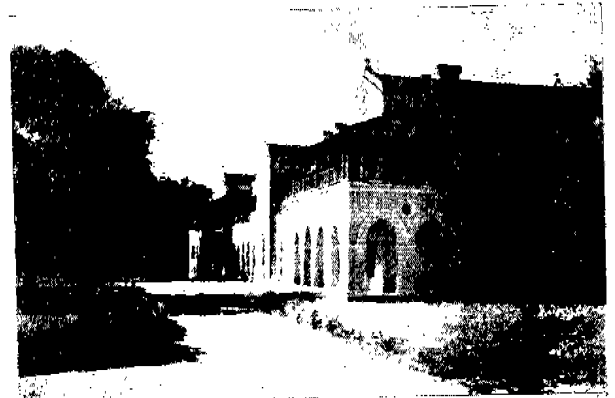

DOUBLE BARRACK

Approved For Release 2004/02/19 : CIA-RDP80-00926A005700070001-3



ENGINEER STUDENTS' CLUB

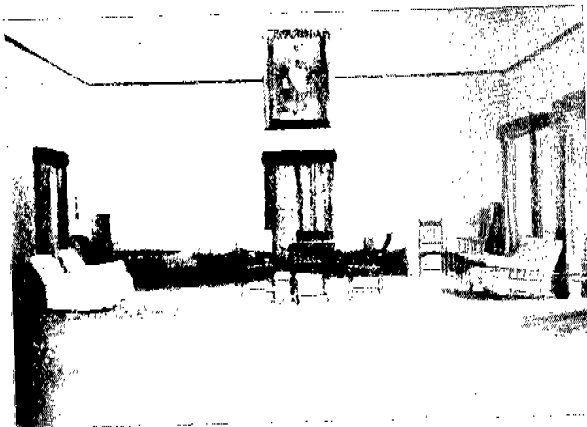

Approved For Release 2004/02/19 : CIA-RDP80-00926A005700070001-3

LOUNGE

Approved For Release 2004/02/19 : CIA-RDP80-00926A005700070001-3



OVERSEER STUDENTS' HOSTELS

OVERSEER STUDENTS' CLUB

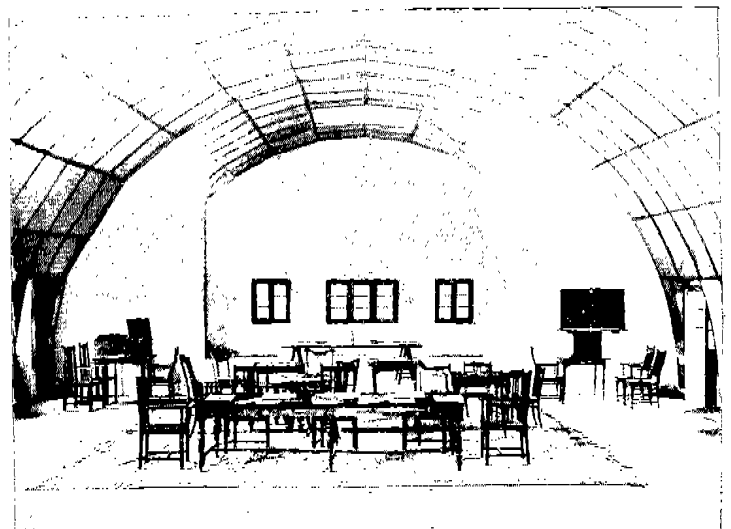

Approved For Release 2004/02/19 : CIA-RDP80-00926A005700070001-3

Approved For Release 2004/02/19 : CIA-RDP80-00926A005700070001-3



COLLEGE CO-OPERATIVE STORES



DAIRY FARM



DAIRY

Approved For Release 2004/02/19 : CIA-RDP80-00926A005700070001-3

Approved For Release 2004/02/19 : CIA-RDP80-00926A005700070001-3

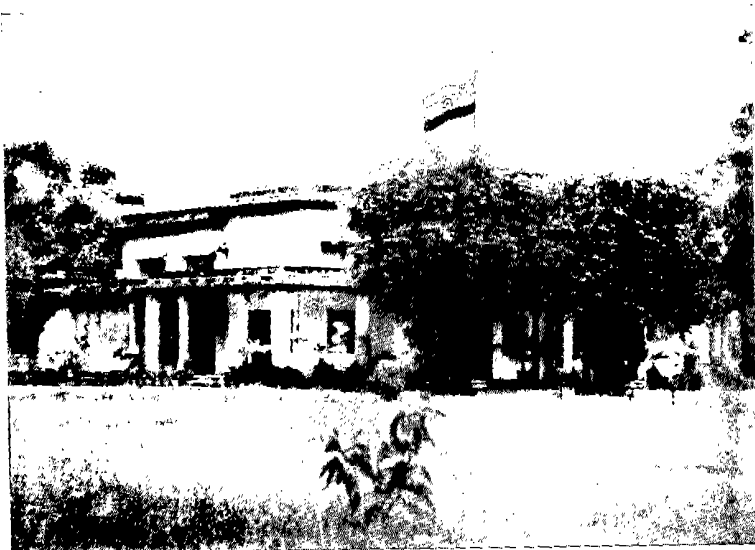

VICE-CHANCELLOR'S HOUSE

PRINCIPAL'S HOUSE

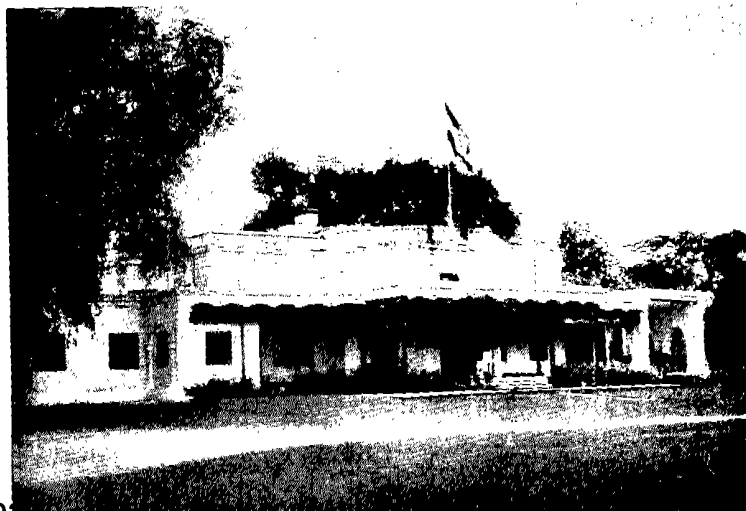

Approved For Release 2004/02/19 : CIA-RDP80-00926A005700070001-3

Approved For Release 2004/02/19 : CIA-RDP80-00926A005700070001-3

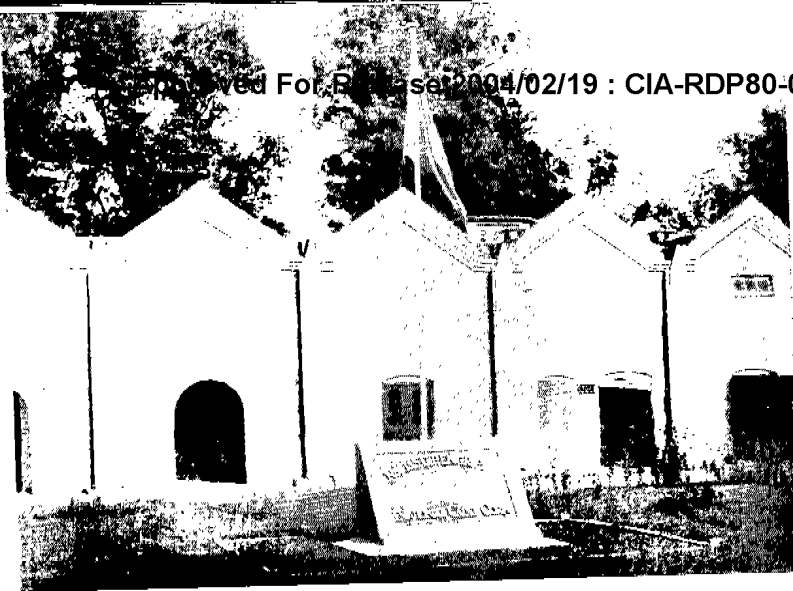

N. C. C. HEADQUARTERS

SOUTH-WEST PACIFIC HANGAR

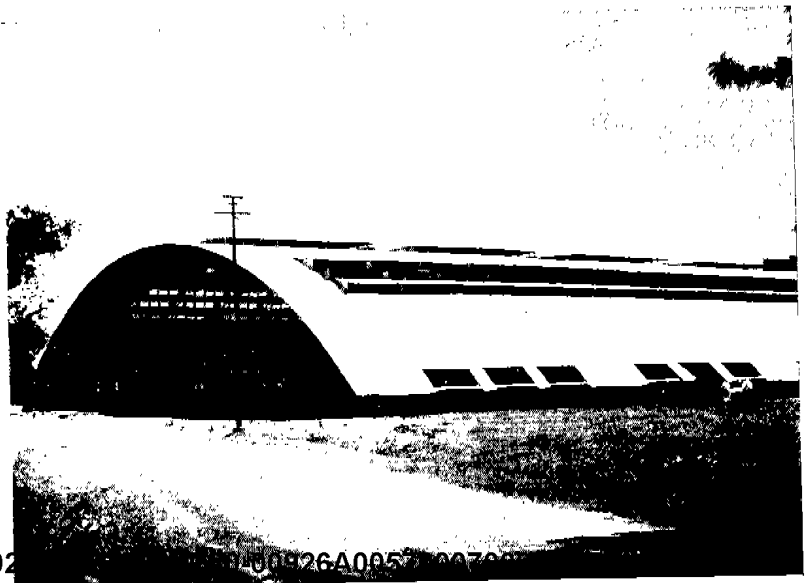

Approved For Release 2004/02/19 : CIA-RDP80-00926A005700070001-3

Approved For Release 2004/02/19 : CIA-RDP80-00926A005700070001-3

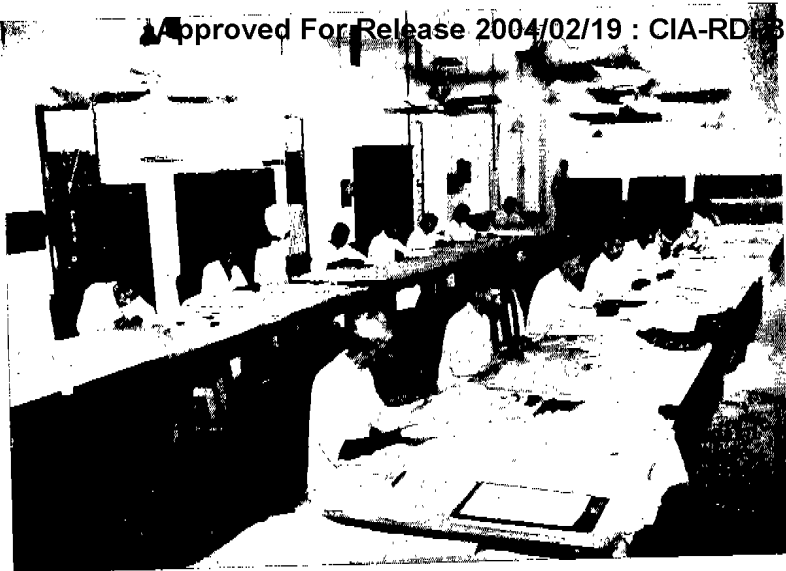

COLLEGE PRESS—
DRAWING SECTION

COLLEGE PRESS—
PRINTING SECTION



Approved For Release 2004/02/19 : CIA-RDP80-00926A005700070001-3

Approved For Release 2004/02/19 : CIA-RDP80-00926A005700070001-3

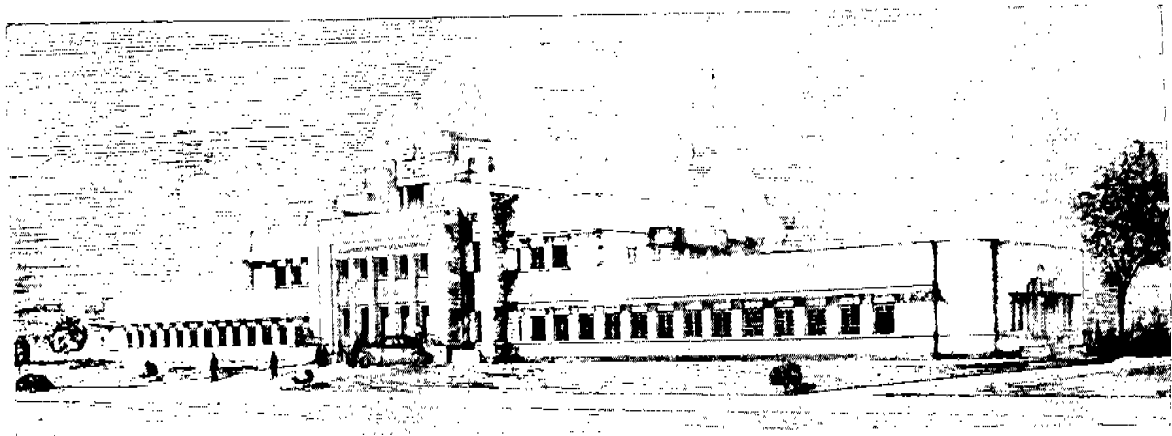

PROPOSED SENATE HALL, MUSEUM AND LIBRARY

(Designed by P. L. Sharma, F.R.I., B.A.)

Approved For Release 2004/02/19 : CIA-RDP80-00926A005700070001-3

2004/02/19 : CIA-RDP80-00926A005700070001-3



N. CHAKRAVARTI, M.I.E.E.
(Present Principal)

Approved For Release 2004/02/19 : CIA-RDP80-00926A005700070001-3

PRINTED BY
M. G. SHOME,
SUPERINTENDENT,
PRINTING & STATIONERY,
U. P., ALLAHABAD.

Approved For Release 2004/02/19 : CIA-RDP80-00926A005700070001-3