

SECURITY INFORMATION  
SECRET  
CENTRAL INTELLIGENCE AGENCY

## INFORMATION REPORT

COUNTRY : USSR

DATE DISTR. 20 JAN 52  
50X1-HUMSUBJECT : Aircraft Development at Zavod #1,  
Podberesje, USSR

NO. OF PAGES 13

PLACE  
ACQUIREDNO. OF ENCLS. : 2  
(LISTED BELOW)DATE  
ACQUIRED

SUPPLEMENT TO 50X1-HUM

DATE OF

THIS DOCUMENT CONTAINS INFORMATION AFFECTING THE NATIONAL DEFENSE  
OF THE UNITED STATES, WITHIN THE MEANING OF TITLE 18, SECTIONS 793  
AND 794, OF THE U.S. CODE, AS AMENDED. ITS TRANSMISSION OR REVE-  
LATION OF ITS CONTENTS TO OR RECEIPT BY AN UNAUTHORIZED PERSON IS  
PROHIBITED BY LAW. THE REPRODUCTION OF THIS FORM IS PROHIBITED.

THIS IS UNEVALUATED INFORMATION

50X1-HUM

1. information on the EF-126 aircraft:

Type : Interceptor  
 Range : 1/2 hour flying time  
 Armament: Two fixed guns ("less than 37 mm")  
 Crew : One  
 Power  
 Plants: One pulse jet (Argus Rohr)  
 Weight : Unknown  
 Span : 4.8 meters  
 Length : 4.5 to 5 meters  
 Speed : Designed for 650 kpm; actual speed: unknown  
 Ceiling : Unknown

- (a) The engine was mounted above the fuselage like that in the V-1 "Buzz Bomb". It was planned to catapult the airplane into the air and have it land on skids. Three were built and one was test flown in Dessau. It was towed up and glided down without using power. On the second flight, the pilot was killed. In Podberesje, one was towed up to altitude, started, and flown without incident.
- (b) The oxygen system, as on all airplanes built in Podberesje, was a German wartime development. The JU-288 had the same oxygen system.

SECRET  
SECURITY INFORMATION

SECRET

50X1-HUM

ATIC	EV		DISTRIBUTION	AEC	X	FBI	X		
------	----	--	--------------	-----	---	-----	---	--	--

**SECRET**  
**SECURITY INFORMATION**

**SECRET**

50X1-HUM

-2-

- (c) [redacted] German 37 mm cartridge belt links were re- 50X1-HUM  
 worked to take a slightly smaller round; therefore, [redacted]  
 [redacted] the caliber used was "slightly less than 37 mm 50X1-HUM  
 but more than 30 mm". 50X1-HUM
- (d) Design work was started in Dessau in August 1945. Junkers  
 engineers had had no previous experience with this type air-  
 plane, and in my opinion, this design was not too success- 50X1-HUM  
 ful. [redacted] the airplanes were disassembled and  
 shipped out along with 12 sets of prints to an unknown desti-  
 nation.

2. [redacted] information on the EF-131 aircraft: 50X1-HUM

Type : Medium Bomber  
 Range : 2000 km, with auxiliary tanks 2500 km  
 Armament: Two 2-gun turrets  
 Crew : Four men  
 Power  
 Plants: Six Jumo 004 Engines  
 Weight : Unknown  
 Span : 16 meters  
 Length : 22 meters  
 Speed : Designed for 750 kph; Actual Speed: 768 kph at  
 2000 meters  
 Ceiling : 5000 meters

- (a) This was a conventional airplane except for its low swept  
 forward wings and three-engine clusters built into the lower  
 surface of each wing. It had tricycle gear with the main  
 gear folding into the fuselage. It also had a parachute to  
 reduce landing distance.
- (b) Auxiliary bomb-bay fuel tanks for increased range were de-  
 signed but not built. The airplane had provisions for  
 emergency dumping of all fuel.
- (c) Armament consisted of two 2-gun turrets of the same caliber  
 as the EF-126. One of the turrets was located on top of the  
 fuselage aft of the cockpit, and one was located below the  
 cockpit. The bomb bay could carry two 1000 kg or four 500  
 kg bombs and possibly other combinations having the same  
 total weight.
- (d) Design work was started about September 1945. The EF-131  
 was ready for its first flight (but was not actually flown)  
 before leaving Dessau. It was disassembled and taken to  
 Russia. [redacted] it made its first 50X1-HUM  
 flight in Podberesje. In all, there were three models as  
 per Junkers policy: two flight test airplanes (V-1 and  
 V-3) and an airplane (V-2) for static test. The Junkers  
 people completed their work on these airplanes about  
 [redacted] and the Russians took the planes and drawings  
 to an unknown destination. 50X1-HUM

3. [redacted] information on the EF-132 aircraft: 50X1-HUM

Type : Heavy Bomber  
 Range : 5000 km (6000 km with auxiliary bomb bay tanks)  
 Armament: Four 2-gun turrets  
 Crew : Six men  
 Power  
 Plant : Six jets plus Rato  
 Weight : 50-60 tons  
 Span : 52 meters  
 Length : 40 meters  
 Speed : Cruising 650 kph, top 750 kph  
 Ceiling : 7000 meters (design)

**SECRET**

~~SECRET~~SECRET  
SECURITY INFORMATION

-3-

50X1-HUM

- (a) This airplane was based on the JU-390. Design was started [redacted] but the project was stopped after the mock-up was built. At this time, [redacted] the Russians professed no further interest, but still took the customary 12 sets of prints. This sudden change in attitude leads me to believe that the Russians are building this plane. 50X1-HUM
- (b) The preliminary drawings and mockup were made with sweat back wings and T-shaped empennage. 50X1-HUM
- (c) \* Three jet engines were buried in line in each wing. One version was planned to use the Jumo 008, and the other to use a Mikulin engine of unknown designation. The thrust is not known for either engine. For added take off thrust and 8-12 second duration or four rockets with 1500 kilo thrust and 12-16 second duration. The type of Rato fuel used is unknown.
- (d) The main fuselage fuel tank had cylindrical compartments inside the tank designed to reduce the effect of gun fire. There were also provisions for emergency dumping of all fuel.
- (e) For armament, the airplane had one chin, one top, one belly (between cabin and bomb bay) and one tail turret. The tail turret was jettisonable. Each turret had two guns of the same caliber as previous airplanes. The tail turret and the top turret were manned. The others were remotely controlled by a hydraulic servo-mechanism designed during World War II by Junkers and known as the FA-15 system.
- (f) The single bomb bay (20 meters long, three meters maximum diameter) could carry three 1000 kilogram bombs in line or six 500 kilogram bombs. No definite plans were made for anything larger although there was talk of carrying one 3000 kg bomb. The bomb bay doors were made in twelve sections, six on each side, that slid up inside the bomb bay. When closed, the sections were interlocked.
- (g) Tricycle landing gear was used. The main gear folded into the fuselage and had a joint in the strut so that the wheel was still in the vertical position when retracted. Each of the main gear wheels was dual tired (side by side). The nose gear folded aft and pivoted to lie flat in the fuselage.
- (h) When the Russian mockup board first came to look at the EF-132, they told the Germans a new crew arrangement would be required as follows:
- (1) "Commandant", who sat farthest forward in the nose. He was in charge of the airplane, did the navigating and also the sighting of the bomb run. He told the bombardier when to release the bombs.
  - (2) Pilot
  - (3) Co-pilot
  - (4) Gunner-bombardier
  - (5) Radio operator
  - (6) Tail gunner

This new arrangement required considerable change in the instrument panels. I believe that this was an impractical arrangement, but it was a Russian requirement made without explanation. The main cockpit and tail gunner's compartment were to be pressurized.

\* [redacted]  
50X1-HUM~~SECRET~~

SECRET **SECRET**  
 SECURITY INFORMATION  
 -4-

4. [redacted] information on the EF-140 aircraft:

Type : Medium Bomber 50X1-HUM  
 Range : 2000 to 2500 km  
 Armament: Three 2-gun turrets; 3-1000 kilo bombs  
 Crew : Four  
 Power  
 Plants: Two Mikulin 4300-4500 kilo each  
 Weight : 48-50 tons  
 Span : 17 meters  
 Length : 24 meters  
 Speed : Designed for 850 kph at 5000 meters; flown at 964 kph  
           at 5000 meters  
 Ceiling : 9000 meters

(a) This was a further development of the EF-131. It also had low swept forward wings although a wind tunnel model had been built with swept back wings. The degree of sweep measured at the mid-chord line was about 26-30 degrees. The aircraft also had a high horizontal stabilizer.

(b) [redacted] Juelge flew the 50X1-HUM  
 V-1 between [redacted] speeds up to 964 50X1-HUM  
 kph. The Russians started flying the V-1 in [redacted]  
 The V-2 was completed [redacted] and the V-3 in [redacted] 50X1-HUM

(c) Zeiss optical sights were used in conjunction with the Junkers FA-15 hydraulic remote control system to operate three 2-gun turrets; one in the lower forward fuselage, one on top of the fuselage between the bomb bay and cabin, and one in the tail. The gun caliber was the same as for previous airplanes.

(d) The bomb bay was 8 to 10 meters long. The bomb bay doors were made in sections like the EF-132. The airplane could carry three 1000 kg bombs.

(e) All of the four man crew rode in the forward section which was pressurized. The crew consisted of:

- (1) Pilot (also navigator)
- (2) Co-pilot (also gunner and bombardier)
- (3) Radioman (also gunner)
- (4) Tail gunner (also flight mechanic)

The above arrangement was also the Russians' idea although it differed from the EF-132. The plane was actually test-flown with a pilot, test engineer, and flight mechanic. Ejection seats were provided for the crew. All seats ejected upward.

(f) The engines used were a later development of those for the EF-132. The EF-140 had two 4300-4500 kg Mikulin engines mounted in pods, one engine on each side, 2.5 meters from the fuselage and .5 meters below the wing. Rate was planned but was not used. There was a parachute in the tail to be used to reduce landing distance. All gear (tricycle) folded into the fuselage.

(g) The fuselage tank did not have the tubular internal construction as designed for the EF-132. There were, however, provisions for dumping all fuel. Tests indicated that all fuel (the tip tanks were not included in the test set-up) could be dumped in one minute, 20 seconds. The symmetrically mounted wing tip tanks were not droppable but could be removed on the ground and replaced by tip fairings.

SECRET **SECRET**

SECRET ~~SECRET~~  
SECURITY INFORMATION

-5-

- (h) Juelge had finished his test flights without encountering any vibration. However, Feodorow, the Russian test pilot, encountered violent tail flutter when he flew this airplane. This occurred in level flight at 360-420 kph.

[redacted] 50X1-HUM  
correct. The tail flutter problem was overcome by installation of stream lined steel weights, under each horizontal stabilizer tip. I remember that these streamlined objects were egg shaped, about 25 cm long and 15 cm in diameter but

- (i) Materials used in the EF-140 were half Russian and half German. I believe that the Russian materials were inferior in strength and more inconsistent in their dimensions and properties.
- (j) The Germans in Podberesje were of the opinion that the Russians were not expediting the German development; probably because of the Russian designers' jealousy of German accomplishments. Reasons given to support this belief were:

- (1) The EF-140 was ready for flight but sat on the ground for four to six weeks before flying because orders to fly were held up and fuel was not made available.
- (2) Bonuses for flight testing were repeatedly put off until "a later date" but were never paid.
- (3) At Ramenskoje, Freytag complained bitterly to Ministerialrat Jangel, calling the delay in the EF-140 program "sabotage". Freytag was warned by Jangel that if he continued this attitude, he might find himself in danger of personal harm.

- (4) [redacted] Baade made two trips to Moscow [redacted] where he gave progress reports to the [redacted] Supreme Soviet of the Soviet Union". On his return, Baade stated that he had received the impression from the discussions following the talks, that there were two factions in the Kremlin. One was in favor of letting the Germans have a free hand, but the majority seemed to favor helping the Russian designers get a medium bomber built before the Germans did. Baade said that he hoped they might be able to offset this discrimination by exerting extra effort. The trips to the Kremlin were on general matters and not in reference to any particular airplane.

- (k) I feel that it was the belief of the Germans that the Russian designers had access to information on German projects and were using it in an effort to be the first to get a medium bomber built.

5. [redacted] information on the EF-150 aircraft:

50X1-HUM

Type : Heavy Bomber and Reconnaissance  
 Range : Bomber 4200 km; reconnaissance 5500 km  
 Armament: Two fixed guns and tail turret  
 Crew : Four  
 Power  
 Plant : Two Mikulin (4900-5000 kg) or  
 Two Lulko (5000-5200 kg)  
 Weight : 55-60 tons  
 Span : 37-38 meters  
 Length : 28-30 meters  
 Speed : 1050 kph top; 900 kph cruising (design)  
 Ceiling : 12000 meters

SECRET ~~SECRET~~

~~SECRET~~ **SECRET**  
 SECURITY INFORMATION  
 -6-

(a) Plans and Progress

50X1-HUM

- (1) The Russians were very interested in this airplane. Very great pressure was exerted to get the airplane built -- "Norms", obligations for the first of May, etc, were set up. The preliminary design work was started [redacted]. The detail design was started [redacted] before all of the preliminary design was completed. Most of the detail design drawings for the experimental airplanes were completed but these would have to be reworked for series production. No series production drawings had been made [redacted] nor did I hear any discussion of series production plans. 50X1-HUM
- (2) Three models of type EF-150 were to be built as usual, except that the static test airplane (V-2) was to be postponed in order to finish the first flight test airplane (V-1). This was in contrast to the usual procedure of completing all static tests prior to flight. In this case, only static tests on critical parts or sections were to be completed before the first flight. 50X1-HUM
- (3) [redacted] Quality control had rejected the fuselage center section which was built by a purely Russian group. It was rejected because the dimensions were not per drawing, the riveting done was very poor, and there were many "oil cans" in the fuselage skin. The bomb bay doors were being built at this time and their dimensions were also inaccurate.
- (4) [redacted] it was still being discussed whether the fuselage should be reworked or a new section should be built, and whether the Russians or the Germans should build the center section. If the fuselage were reworked, [redacted] the earliest flying date of the airplane would be about April 1951, instead of late 1950 as originally scheduled. If a new fuselage center section were built, the V-1 would fly about May - June 1951. In the event that a completely new section were made, parts from the V-3 would probably be used. From my experience in the plant, [redacted] the most logical and probable decision would have been to have a new section built by the Germans. 50X1-HUM
- (5) [redacted] only Russian workers and foremen were selected to build the center section of the fuselage as the first attempt to replace the Germans with Russian personnel in the plant. Russian quality control was used on this section of the fuselage. The other parts of the airplane were built under German supervision. Overall quality control was still under German supervision and was as exact as that for the EF-140. The Russian fuselage center section group was also supposed to construct the V-2 and V-3 center sections; but after the experience with the V-1, [redacted] this plan was probably changed. 50X1-HUM

~~SECRET~~**SECRET**

**SECRET**

50X1-HUM

**SECRET**  
**SECURITY INFORMATION**

-7-

- (6) [redacted] the 50X1-HUM  
 following parts were under construction for the V-1: wings, empennage, cockpit, gas tanks (tubular internal construction), tail section of fuselage, and the landing gear. The mock-up of this plane had been completed with the left wing omitted. The mock-up was 90% wood construction although the engine housing was made of metal and the cockpit had a tubular steel framework. [redacted] the V-2 gas tanks and cockpit were being tested. The wings, fuselage, empennage, and landing gear were not yet ready for testing, although they were under construction. For the V-3, only individual parts were being made. 50X1-HUM

- (7) Feodorow, a Russian test pilot and hero of the Soviet Union, was scheduled to fly the EF-150. The V-3 might possibly have flown in August or September 1951. This opinion is based partly on my knowledge of the capabilities of the plant and partly on letters from friends in Podberesje, telling of bonuses which they received. I have no definite information as to whether either airplane has flown; however, Baade wrote to Richter in September 1951 asking questions about housing, transportation, etc, so I assumed the work in which Baade had been engaged was finished and that Baade contemplates returning to Germany.

**(b) General Description**

- (1) The project, as initially conceived in the preliminary design section, had low swept back wings and had the horizontal stabilizer located in the center of the vertical stabilizer. The Russians had the horizontal stabilizer moved up into a "T" configuration.
- (2) The sketches, Enclosures (A) and (B) of this report, were made under my direction and in such a way that the wing location was left until last, so that other items such as engine and fuselage height above the ground would aid in determining the wing configuration. Note that the wing configuration does not agree with previous reports, in particular, [redacted] The information on these drawings is based upon [redacted] 50X1-HUM  
 [redacted]  
 was necessary for workmen to use a work stand to get up to the tip tank, indicating an appreciable amount of wing dihedral.
- (3) There were no wing stall fences but [redacted] the preliminary design included moveable leading edge slots. Further details are unknown. 50X1-HUM
- (4) The horizontal stabilizer could be adjusted electrically between minus four and plus eight degrees angle of incidence during flight.
- (5) The Russians also increased the range requirements of the reconnaissance version from about 4800 km to 5500 km. The final design range of the bomber was 4200 km, with a bomb load of 3000 kg.

SECRET

**SECRET**

~~SECRET~~  
 SECRET  
 SECURITY INFORMATION  
 -8-

50X1-HUM

- (6) The reconnaissance airplane was to have a bomb bay tank 10 x 4 x 1.8 meters. On both versions, the wing tip caps could be removed and fuel tanks installed. It was planned to provide a means of dumping all fuel, but there were no plans for single point refueling.
- (7) The EF-150 had bicycle type landing gear. Each main gear wheel had dual tires. The outrigger gear consisted of small single tired wheels retracting into the engine nacelles. 50X1-HUM
- (8) No cameras were intended for the bomber. [redacted] that one camera was to be placed in the nose of the reconnaissance version.

(c) Power Plants

- (1) For the V-1 airplane, drawings were made for either of two engines; an improved Mikulin (about 4900-5000 kilo thrust) or a Lulko (5000-5200 kilo thrust). [redacted] completed engines of either version 50X1-HUM metal mock-ups of both engines; these mock-ups did not include engine accessories. It was the opinion of Baade and other German engineers, that neither of the engines were ready, and that the first engine available would be the one installed. The two engineers, Hoch and DuBois, who with Baade were responsible for engine installation, had discussions with both Lulko and Mikulin engineers regarding the construction and installation of these engines. 50X1-HUM
- [redacted] LULKO and Mikulin with whom Baade talked to personally in Moscow. ) Hoch and Du Bois stated that these engineers could answer any technical questions put to them, but could not or would not tell the Germans if the engines were ready. The Russian deputy to Baade, Obruchow, told the German engineers that both of these engines were available for use. [redacted] no other engine planned for the EF-150. 50X1-HUM
- (2) There was talk of after-burners but [redacted] if these engines actually had any means of thrust augmentation. Both engines had moveable cones to adjust the tail pipe area. [redacted] this could be accomplished in flight. There were also provisions for two 1000 kilo Rates of 12 to 16 sec duration, attached to the fuselage about two-thirds of the way aft. 50X1-HUM
- (3) Engine drawings available to the Germans indicated no factory location, and [redacted] any plant sites. 50X1-HUM

(d) Crew and Facilities

The crew consisted of four men who had duties similar to those described for the EF-132: commandant-navigator, pilot, co-pilot-bombardier, rear turret gunner. Ejection seats were provided for the crew in the front compartment. The commandant was ejected downward, the other two upward. The tail gunner was provided with an exit door which was operated hydraulically and held open to act as a wind deflector. All compartments were pressurized but the front and rear compartments were not connected. At 12,000 meters, the cabin pressure was to be that of 2,000-3,000 meters. [redacted] how pressure was maintained or what the pressure-altitude schedule was. 50X1-HUM

SECRET ~~SECRET~~



SECRET ~~SECRET~~  
SECURITY INFORMATION

50X1-HUM

-9-

(e) Armament

- (1) Believing that the speed of the aircraft reduced the armament requirement, the designers provided only the rear revolving turret with twin cannon ("less than 37 mm") and a fixed single cannon on each side of the cockpit. There were no remote control features for the tail turret. Optical sights were used. There was a "Nachtvisier" attachment which was used at night and in fog, but I have no further details on this attachment. I do not know if it was simply an electrical sight illumination, an infra-red system, or what; but it was not radar.
- (2) Bomb sighting could be accomplished by means of radar. The bomb load was 3000 kg (one 3000 kg bomb or various numbers of smaller bombs). A hand operated bomb hoist was provided. The hoist was removed after the bombs had been hung. Bomb doors were sectional and slid inside the bomb bay like the EF-132. On the test stand, 45-50 seconds were required to open the doors.

(f) Equipment

- (1) Filtered exhaust gases were used for anti-icing the leading edges of wings and empennage. There were no provisions for anti-icing the air intake of the engines, although there was a screen in the air intake. There was a chemical cartridge between the glass panes of the windshield which was used for removing moisture and possibly frost. [redacted] provisions for tapping off air from the engine compressor section. 50X1-HUM
- (2) Pneumatic systems were not used in this airplane, but hydraulics were used for landing gear, bomb bay door, tail gunner's escape hatch, and brakes.
- (3) Electrical actuators were used to adjust the horizontal stabilizer and the trim tabs on the rudder and ailerons. [redacted] 50X1-HUM  
[redacted] there were, however, plans for the installation of more than one battery but I do not know what the electrical connection was to be.
- (4) The liaison engineers had very little contact with the electrical sections and I have no knowledge of radar; however, the head of the electrical section said that any radar used was of German design and had been brought from Dessau. Cockpit instruments were reworked German equipment.
- (5) Flight control surfaces were actuated by dural pushrods, torque tubes, and combinations of both. Cables had not been used in any Junkers airplane since [redacted] 50X1-HUM  
[redacted] Junkers engineers wanted to avoid rigging maintenance difficulties. A hydraulic servo-boost mechanism for all axes had been built, had passed tests, and was to be used on the EF-150. I know of no research being conducted on pure-power flight control systems, although the FA-15 hydraulic gun turret system was operated without mechanical linkage between the sight and turret. 50X1-HUM

SECRET ~~SECRET~~

**SECRET**   
**SECRET**  
 SECURITY INFORMATION

50X1-HUM

-10-

**(g) Production Problems**

In addition to the poor work on the fuselage, other production problems existed. Difficulties were encountered in securing the large sizes of sheet metal required in building the EF-150. The drawing specifications called for aluminum 4 mm thick and larger than 2.5 m x 3 m. Some of these sheets had to be spliced by spot-welding to get the required size. The first forgings received for the landing gear were defective and looked like castings full of blow holes. These parts were later replaced by new ones. Spar caps had to be milled from round stock as the proper size extrusions were unavailable. There was practically no German material available for this airplane, and it was built almost entirely of Russian material, which was quite inferior to the German. The only main structural members made from steel were the bomb racks and the structure to carry the wing spar loads through the fuselage. Main control columns and rudder pedals were made of "electron" (magnesium alloy). The magnesium parts were not made at Podberesje and I have no idea where they were obtained.

**(h) Wind Tunnel Work**

Wind tunnel work was done both in Podberesje and in Moscow. All wind tunnel models were constructed in the model workshop connected with the wind tunnel at Podberesje. Steel models of various scales were tested and, as far as I know, no wood models of the EF-150 were tested.  both full and half-span models; the largest full span steel model  had 1.80 meters wing span and was about 1.50 meters long. The motor nacelles were solid. This model was sent to Moscow for testing.

50X1-HUM

50X1-HUM

6.  activities of the Siebel group at Podberesje, who were working on a supersonic liquid rocket interceptor: 50X1-HUM

Type : Interceptor  
 Range : Unknown  
 Armament: Unknown  
 Crew : One (prone position)  
 Power  
 Plant : One liquid rocket ("Walther Ofen") 50X1-HUM  
 Weight : Unknown  
 Span : Unknown

- (a)  whether this aircraft was model 346 or 426. The plane had one "Walther Ofen" using "T&C" fuel. It had a sharp nose (ogive), swept back wings, and high horizontal stabilizer. The pilot rode in the prone position in a jettisonable cockpit.
- (b) During the first test flights, it was towed upstairs by a JU-88. In later tests, it was carried under the wing of a TU-4. (I believe that this plane was described in an American publication in 1947 or 1948.) Letters from Podberesje indicate that two satisfactory flights were made in May 1951.
- (c) While this was the only Siebel aircraft actually built at Podberesje, many designs were made and sent to Moscow. All of these designs were for supersonic aircraft, but I do not know if they were piloted or not.

-end-

SECRET

**SECRET**

SECRET  
SECURITY INFORMATION

50X1-HUM

- 11 -

Biographical Index of Names Appearing in this Report

- |                                   |   |
|-----------------------------------|---|
| 1. Baade, Brunolf (Dipl Engineer) | Chief Designer for the Junkers group at Zavod #1, Podberesje, USSR                            |
| 2. DuBois, Georg (Engineer)       | Engine installation designer with the Junkers group   |
| 3. Feodorow, (fnu)                | Russian Test Pilot  |
| 4. Freitag, Fritz (Engineer)      | Deputy Chief Designer of the Junkers group  |
| 5. Hoch, Hans (Engineer)          | Engine installation designer with the Junkers group   |
| 6. Jangel, (fnu)                  | Russian Ministry official in Moscow; exact position unknown                                   |
| 7. Juelge, Paul                   | Chief Test Pilot with the Junkers group   |
| 8. Obrubow, (fnu)                 | Russian Deputy to Chief Designer Baade  |
| 9. Richter, Erich (Engineer)      | Formerly a technician liaison engineer with the Junkers group and now living in the East Zone |

SECRET

**SECRET**

SECRET  
SECURITY INFORMATION

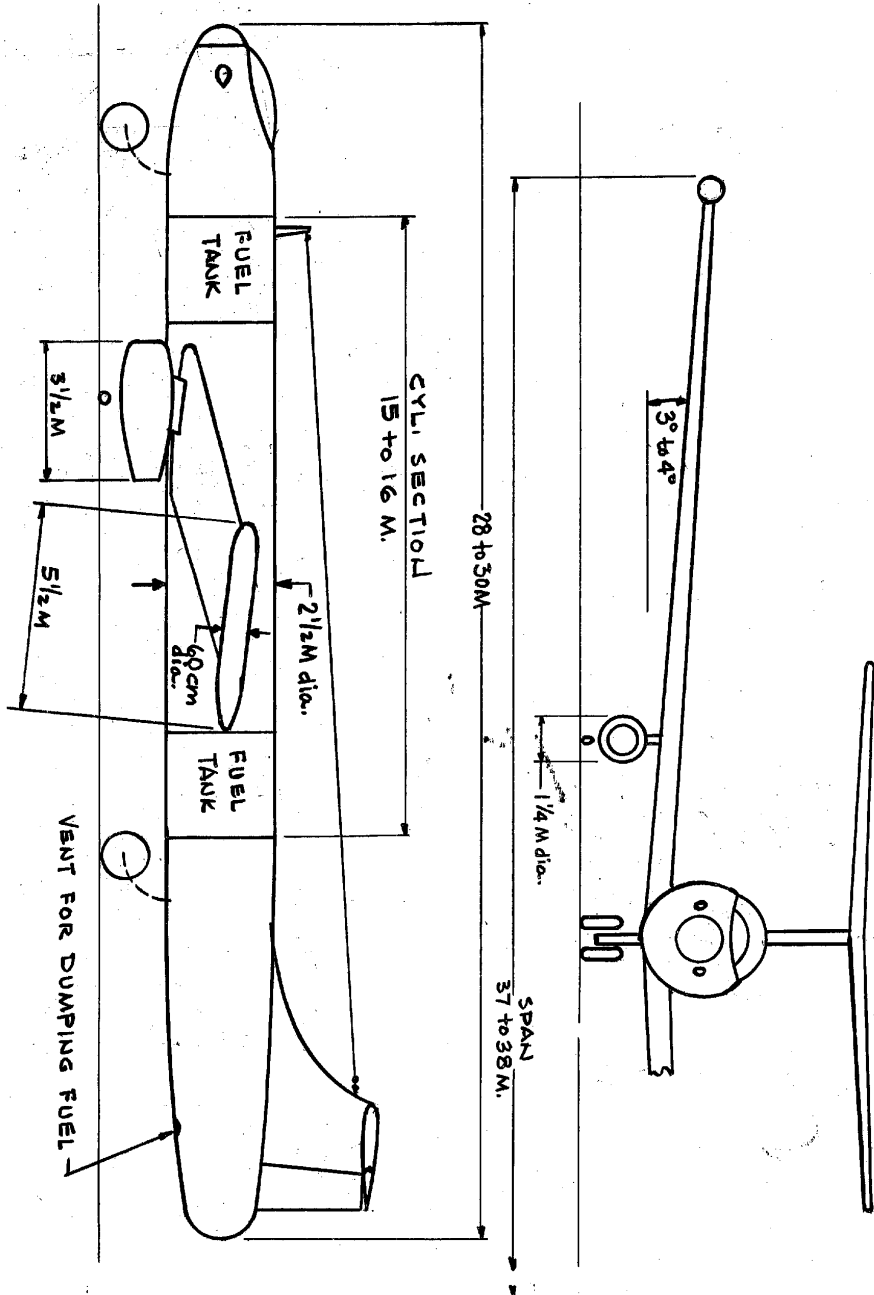

NOTE: ALL DIMS ARE APPROX.

APPROX. SCALE 1:150

SIDE & FRONT VIEW  
MODEL EF150

Enclosure (A)

SECRET

~~SECRET~~ ~~SECRET~~  
SECURITY INFORMATION  
- 13 -



50X1-HUM

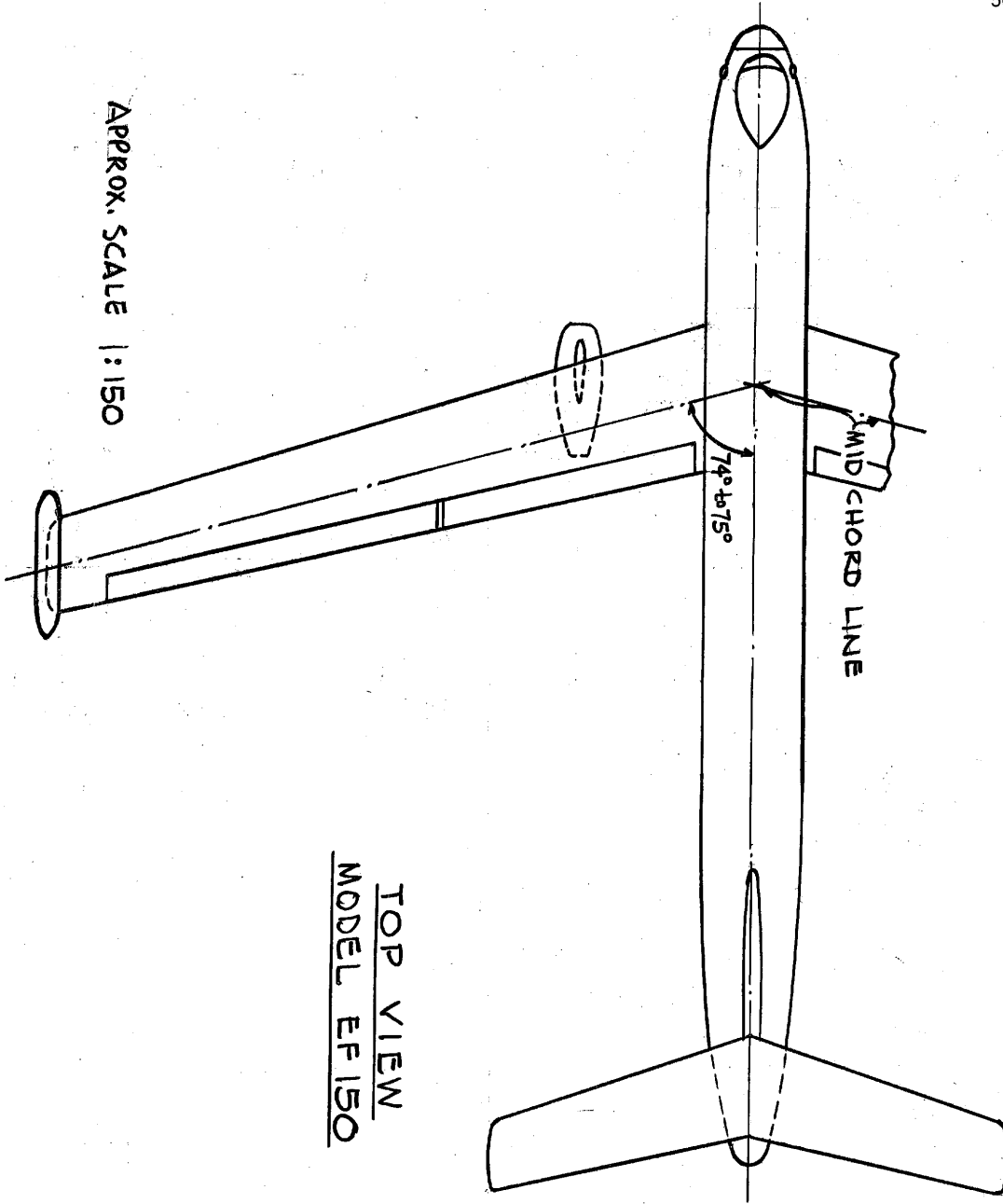

APPROX. SCALE | : 150

TOP VIEW  
MODEL EF-150

Enclosure (B)

~~SECRET~~