

SECRET

USAF Declass/Release Instructions On File

Informal Monthly Progress Report No. 5

For The Period

16 May 1955 through 12 June 1955, Inclusive

Contract No. A-101

CMCC Document No. 163.2005

Copy 1 of 7

This document contains information affecting the National Defense of the United States within the meaning of the Espionage Laws, Title 18, U. S. C., Sections 793 and 794. Its transmission or the revelation of its contents in any manner to an unauthorized person is prohibited by law.

SECRET

SECRET

1.0 Antennas.

Four antennas and feeds have been matched on each frequency and made ready for flight testing.

The S and X-band feeds were gold plated and were sealed at the dipoles to resist corrosion. The S-band feed was sealed with .0015 inch Mylar sheet and Epon adhesive and the X-band feed was sealed with .002 inch mica sheet and Epon adhesive. The completed S and X-band assemblies, together with crystal holders, weigh 10.0 ounces and 6.3 ounces, respectively.

Since both horizontally and vertically polarized X-band transmissions will be received during operation, the X-band antennas will be installed with the dipole axes 45° from horizontal to obtain equal sensitivity for either polarization. This will result in a 3 db loss in absorbed power.

In a typical S-band V-beam radar set one beam is horizontally polarized and one beam polarized 45° from horizontal. The receiving antenna is horizontally polarized and the 3 db loss in absorbed power from the 45° beam serves as an aid in identifying the main beam.

The open circuit detector voltage for an incident r-f field intensity of 1 milliwatt per square meter has been computed from measured antenna gains and VSWR values for the antenna and detector. The computed detector voltages are 28 millivolts at S band and 6 millivolts at X band (including the 45° antenna rotation).

The dishes are being fabricated by the Raymond De-Icer Company. The wooden molds being used are warping to the extent that it is almost a certainty that production quantities cannot be obtained from the present molds. The company is not willing to work from wood tooling for the remaining quantities. The estimate for metal tooling is approximately \$7000.00 for the S and X-band dishes. For this reason, engineering drawings of the dishes will be submitted to several companies for bids. The original bids were made for antennas of a more experimental nature. Complete drawings and specifications can now be furnished.

Ten S-band feeds are being manufactured by the contractor. Vendors are being contacted to bid on the remaining quantities of S and X-band feeds.

2.0 Information Amplifier.

The design of the information amplifier was completed after receipt of a satisfactory pulse transformer from Mag-Electric Co., of Hawthorne, California. Figure 1 is a schematic diagram of the completed amplifier.

SECRET

SECRET

Two minor changes have been included in the final design:

- a. A trigger amplifier was added preceding the one-shot multi-vibrator that discharges the pulse stretching circuit. This maintains uniform pulse stretching throughout the dynamic range of the amplifier.
- b. The output stage has been converted to a cathode-follower. Because of increased gain in the final design, amplification in the output stage is no longer required.

Four hand-wired models of the prototype amplifier have been completed and tested. A production model using printed wiring has been designed.

Figure 2 is a curve of amplifier-output current as a function of input voltage. Figure 3 is a curve of output current as a function of input pulse width. Figure 4 is a schematic diagram of the high voltage power supply. The unit is designed to operate in ambient temperatures as high as 160°F.

3.0 Information Recorder.

Design of the production model of the recorder is about 50% complete.

One prototype recorder has been assembled and a second prototype recorder is being assembled.

There is approximately 4% flutter in the prototype recorder. The flutter arises from two primary sources, the gear teeth and the capstan. A tuned filter consisting of a small flywheel and a fluid-damped spring has been used in a variety of configurations without appreciable success. The space and weight requirements of the recorder have made it difficult to eliminate end effects and distortion in the compliance elements of the filter. Tests using the flywheel and replacing the spring with foam rubber were encouraging. Both a belt and rubber puck-type drive will be completed for testing in the immediate future.

Tests using the prototype recorder indicated a noise level at the reproducing head output of about 3 microvolts rms. The noise level of the transistor monitor amplifier referred to its input was prohibitively high -- between 50-100 microvolts rms. For this reason a vacuum tube monitor amplifier (figure 5) was constructed. The noise level of this unit, referred to the input grid, is less than 1 microvolt rms.

Figure 6 is a schematic diagram of the transistor bias-oscillator. At a frequency of 20.5 kc the unit supplies 0.6 ma rms bias current to each recording track and 8 ma rms erase current. The frequency

SECRET

SECRET

deviation is 2 1/3 cps over the temperature range from 27°C to 87°C. The voltage across the erase head varies less than 2% over the same temperature range.

Information was received during this progress period that five oscillators would be required for the timing track of the recorder. There is enough room in the production design of the recorder to incorporate five transistor type R-C phase shift oscillators. The presence of each oscillator will indicate a timing event. Since these events may occur simultaneously it is necessary to be able to filter and identify separate frequencies in the playback process. An R-C phase-shift oscillator using two 903 silicon-junction transistors is being designed to operate between 1 kc and 3 kc to accommodate the above requirements.

4.0 Test Set.

Figure 7 is a complete schematic diagram of the test set. The prototype model of the test set is presently being built and will be completed by the end of June. However, the S-band attenuator required for the prototype model will not be delivered until July 10.

5.0 Dubbing Equipment.

The first set of Ampex dubbing equipment has been received.

The playback recorder was modified to operate at the same speed as the System 1 recorder. This was accomplished by replacing the Ampex motor and capstan with a custom-made motor and capstan designed to drive the tape at 2 1/4 inches per second. For tests using the prototype recorder, a second motor and capstan was purchased to drive the tape at 1 7/8 inches per second.

The recording amplifiers have been modified to equalize the pulse response of the system. The re-recording is made at a tape speed of 7 1/2 inches per second. The output of the copy tape is a differentiated pulse. To obtain a flat response from the information amplifier input, to and including the playback of the copy tape, an adjustment of the equalization control is required. Instructions for this adjustment, along with copies of the tape and a Probe to eliminate the undesired peak of the differentiated pulse, will be provided.

These modifications and adjustments, without attempting to reproduce the original pulse waveform, provide faithful reproduction of relative amplitudes over a 40-46 db dynamic range and for pulse repetition rates of 300-3000 pps.

Reproduction of the original recorded pulse-waveform through equalization in the dubbing process would necessitate further extensive modification in standard Ampex equipment and is not practical.

SECRET

SECRET

6.0 Flight Tests.

The trainer aircraft will not be delivered in time for a mid-June flight test. The flight test, therefore, has been rescheduled for the early part of July.

7.0 Man-Hours Expended.

A total of 6718 man-hours was expended during the interval reported in this progress letter.

SECRET

SECRET

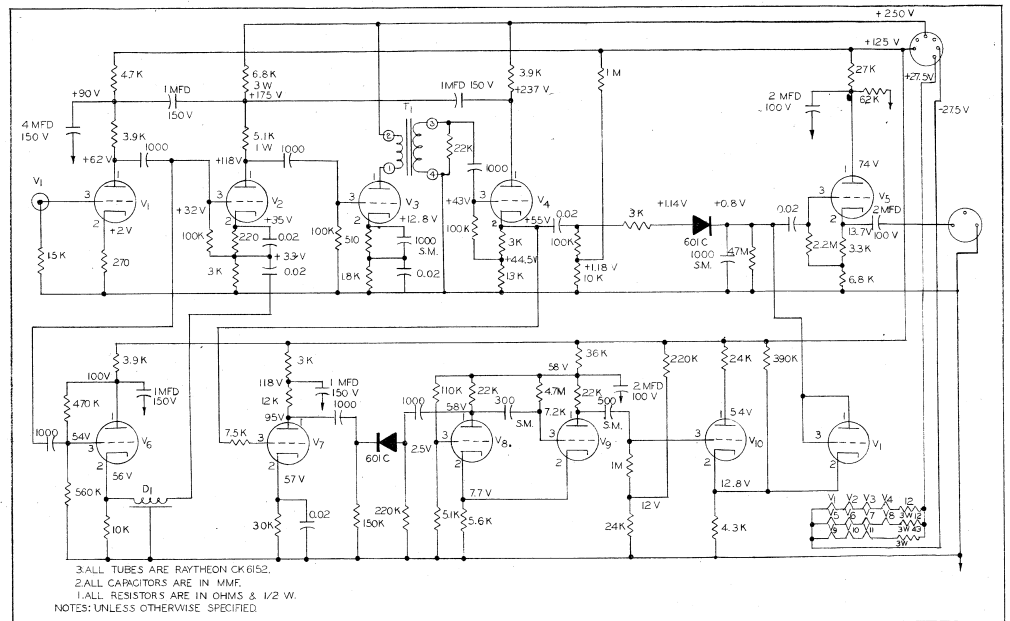

50195022

CHOC NO. 2114.307 Copy 1

SECRET

SECRET

50099026

CRCC No. 211-308 Copy 1

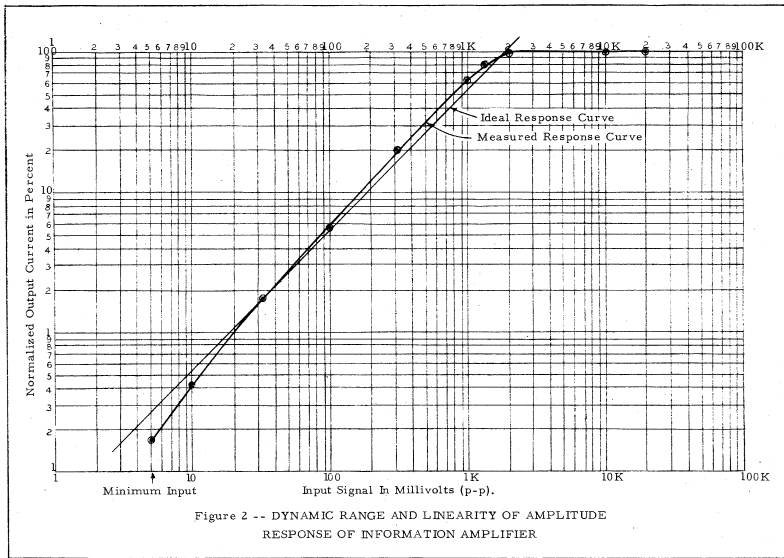

SECRET

SECRET

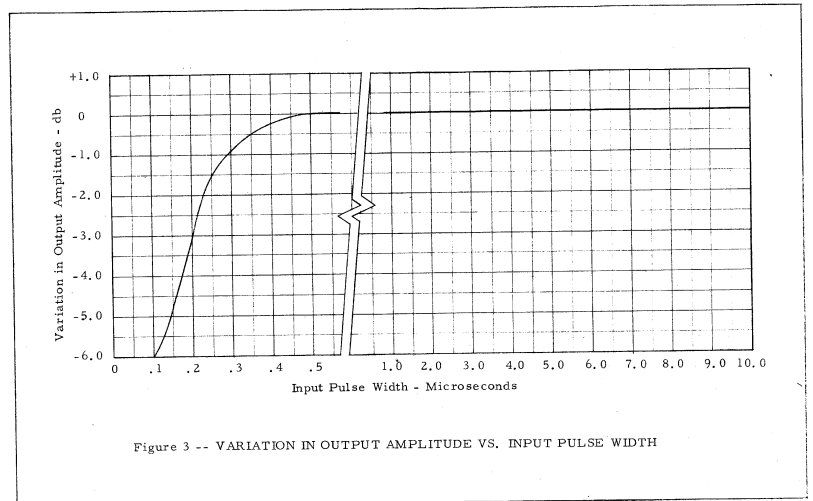

Figure 3 -- VARIATION IN OUTPUT AMPLITUDE VS. INPUT PULSE WIDTH

50152027

ORCC No. 211-309 Copy 1

7
SECRET

50199085

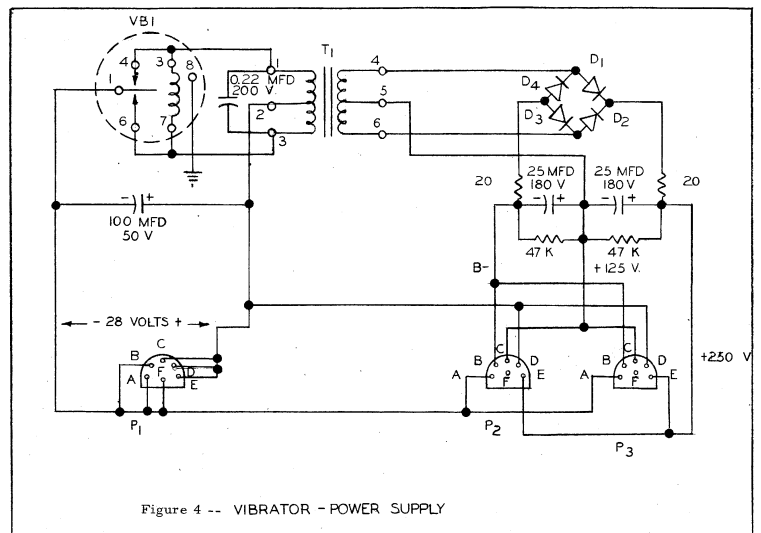

50199023

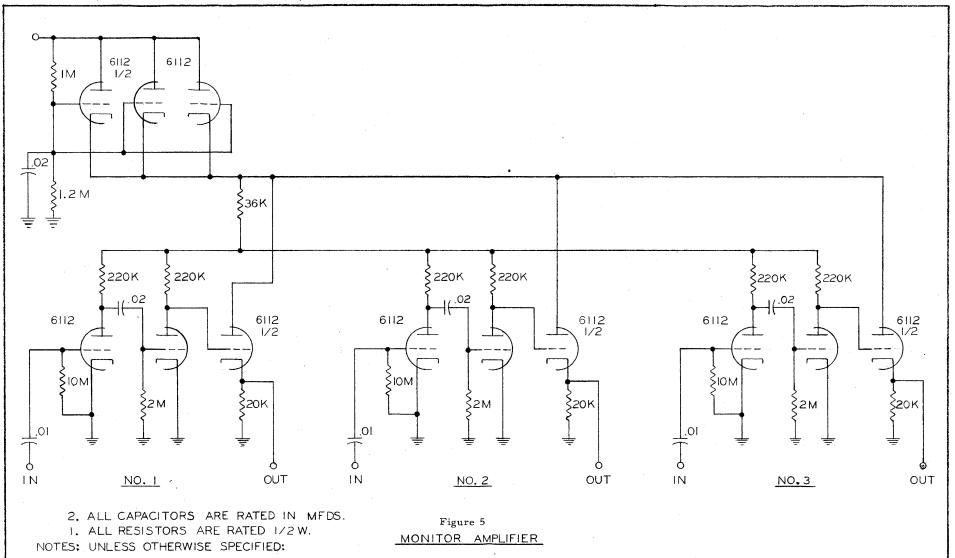

2. ALL CAPACITORS ARE RATED IN MFDS.
1. ALL RESISTORS ARE RATED 1/2 W.
NOTES: UNLESS OTHERWISE SPECIFIED:

Figure 5
MONITOR AMPLIFIER

50109021
1206705

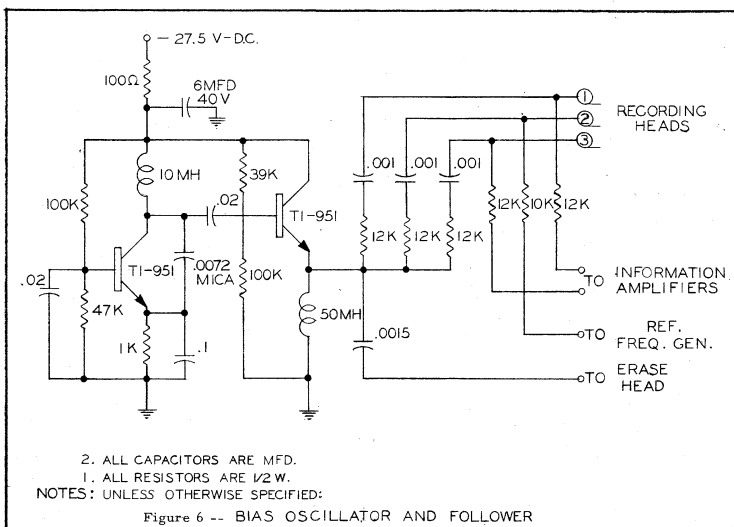

SECRET

50471903

CIRC NO 247226 COPY 401

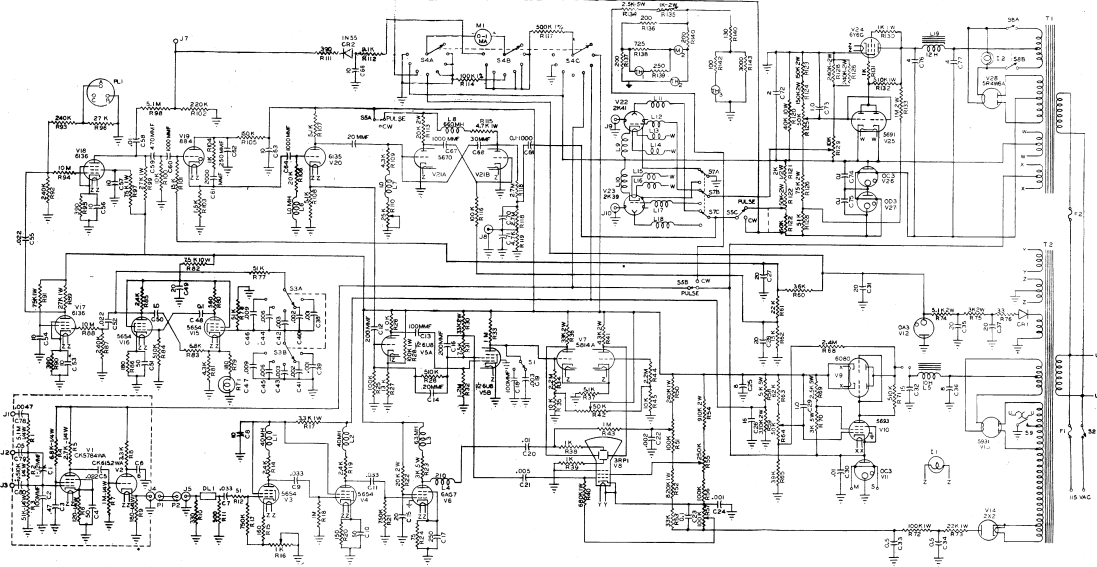

- 1. ALL RESISTORS IN OHMS (Ω) UNLESS OTHERWISE SPECIFIED
- 2. ALL CAPACITORS IN MICROFARADS (μF)
- 3. ALL INDUCTORS IN MILLI-HENRIES (MH) UNLESS OTHERWISE SPECIFIED

Figure 7 - TEST SET

SECRET