

SHVARTSAFEL', ENG. YE.

MEAT INDUSTRY

Growing enterprise. Mias. ind. SSSR 23 no. 3 (1952)

9. Monthly List of Russian Accessions, Library of Congress, September 195~~7~~₂, Uncl.

KUL'BERG, L.M.; SHVARTS BURD, M.M.

New method for the detection of iodide impurities in bromides.
Ukr.khim.zhur.17 no.5:799-800 '51. (MLBA 9:9)

1.Saratovskiy gosudarstvennyy universitet.
(Iodides) (Bromides)

SHVARTS BURD, M. M.

Qualitative and quantitative determination of analgene.
 L. I. Razonov and M. M. Shvartsburd. *Aplechnoe Delo*
 3, No. 5, 47-53(1954). In the detection treat 0.005-0.01
 g. of analgene with 1 cc. of concd. H₂SO₄ contg. traces of
 salicylic acid (the edges of the crystals become colored) or
 treat 1 cc. of a 1% aq. soln. of analgene with 5-6 drops of a
 20% soln. of dimethylaminobenzaldehyd in concd. H₂SO₄
 (the soln. is colored yellow and the color does not disappear
 on addn. of 5 cc. H₂O). The following drugs do not inter-
 fere with the identification when both reactions are used:
 antipyrine, Salpyrin, streptocid (white), Urotropin, phen-
 acetin, acetanilide, phenobarbital, caffeine and its salts, co-
 deine, dionin, Na salicylate, NaBr, aminopyrine, and as-
 pirin. To det., dissolve 0.15 g. analgene in 10 cc. H₂O, add 1
 drop of 0.15% soln. of methylene blue, and titrate the soln.
 with 0.1N I. The change of color from blue to green re-
 mains stable for 15-20 sec. and the appearance of turbidity
 indicates the end of the reaction; 1 cc. 0.1N I = 0.017568 g.
 analgene. In another method of detn., dissolve 0.13-0.16 g.
 of analgene in 0.5 cc. H₂O, add 5 cc. of alc. and 2 cc. of CH-
 Cl₃, and slowly titrate the mixt. with a 0.1N ICl soln. in
 HCl until the pink-violet color of the upper layer and the
 yellow color of the lower disappear; 1 cc. of 0.1N ICl =
 0.017568 g. analgene. Drugs which do not interfere with the
 detn. are caffeine, phenacetin, aspirin, acetanilide, NaBr,
 codeine, dionin, and phenobarbital; those which interfere
 are Na salicylate, Na benzoate, antipyrine, Salpyrin, and
 Urotropin. The interfering drugs can be removed by
 dissolving in Et₂O; analgene is insol. A. S. Mirkin

MA 204

SHVARTS BURD, M.M., analitik

Troublesome qualitative reactions in complex medicinal compounds.
Apt.delo 6 no.3:52-55 My-Je '57. (MIRA 11:1)

1. Iz apteki No.24 v Kiyeve (upravlyayushchiy N.I.Tkachuk)
(CHEMISTRY, MEDICAL AND PHARMACEUTICALS)

SHVARTS BURD, M.M., analitik

Consecutive detection of two or three ingredients with one reagent
or in the course of one reaction. Apt.delo 9 no.1:60-61 Ja-F '60.
(MIRA 13:6)

1. Iz praktiki apteki No.24 Kiyeva.
(DRUGS--ADULTERATION AND ANALYSIS)

SHVARTSBURO, M.P., inzh.

Examples of redesigning parts in order to improve their operational efficiency. Stroi. i dor. mashinostr. 2 no.11:35-36 N '57.
(Building machinery) (Road machinery) (MIRA 11:1)

SHVARTSUD, M.P., inzh.

Initiator of introducing progressive work methods everywhere. Stroi.
i dor. mashinostr. 3 no.1:39 Ja '58. (MIRA 11:1)
(Dubchak, G.N.)

SHVARTS BURD, M.P., inzh.

Improving equipment at the January Uprising Plant. Stroi. i dor.
mashinostr. 3 no.2:35-36 F '58. (MIRA 11:2)
(Machine tools--Attachments)

SHVARTS BURD, M.P.

Progressive practices of the January Uprising Plant. Stroi. i dor.
mashinostr 3 no.5:33-34 My '58. (MIRA 11:6)
(Lathes--Attachments)

SHVARTS BURD, M.P., inzh.

Experience in machining workpieces. Stroi. i dor. mashinostr. 3
no. 8:31 Ag '58. (MIRA 11:8)

(Milling machines)

SHVARTS BURD, M.P., inzh.

Forger and innovator. Stroi. i dor.mashinostr. 3 no.11:38-39
N '58. (MIRA 11:11)
(Ovsiannikov, Dem'ian Vasil'evich)

SHVARTS BURD, M. P.
SHWARTS BURD, M.P., inzh.

Standardization of pressure lubricators for cranes. Stroi. i dor.
mashinostr. no.4:35 Ap '58. (MIRA 11:4)
(Lubrication and lubricants)

AUTHOR: Shvartsburd, M.P., Engineer 117-58-6-20/36

TITLE: A Grease Gun Head for Lubricators With Consistent Lubricants
(Golovka shpritsa dlya maslenok konsistentnykh smazok)

PERIODICAL: Mashinostroitel', 1958, Nr 6, p 31 (USSR)

ABSTRACT: The grease gun heads now produced according to GOST 3027-45, are complicated and do not resist pressures higher than 150 kg per cm². In the Odesskiy kranovoy zavod imeni "Yanvar'skogo vosstaniya" (Odessa Crane Plant imeni "Yanvars-koye vosstaniye" a new head was devised, which is simpler and is resistant to pressures of 250-300 kg/cm². The device is represented in the figure. There is 1 figure.

AVAILABLE: Library of Congress

Card 1/1 1. Grease gun heads-Design

25(7)

SOV/117-59-3-25/37

AUTHOR: Shvartshurd, M.P., Engineer

TITLE: A Two-Mill Set for Milling the Teeth of a Ratchet Wheel (Nabor iz dvukh frez dlya frezerovaniya zub' yev khrapovika)

PERIODICAL: Mashinostroitel', 1959, Nr 3, p 39 (USSR)

ABSTRACT: The described special holder for two milling cutters, one rough and one finishing, permits the semi-automatic machining of four large ratchet wheels in one setting on a "Komsomolets" gear milling machine. It is now in use also on a "5342" gear cutter of the Kolumenskiy zavod tyazhelogo mashinostroyeniya (Kolumna Heavy Machine Tool Building Plant). The two mills work in couple and perform the rough and the finish cut at one time. The idea has eliminated the subsequent fitting of the ratchet wheels with the use of templates. The work rate rose 40%, and the work quality improved. There is 1 photograph.

Card 1/1

PELEVIN, M.A., inzh.; SHVARESBURD, M.P., inzh.

Universal equipment for hardening parts by high-frequency currents.
Stroi. i dor. mashinostr. 4 no. 5:33-35 My '59. (MIRA 12:7)
(Metals--Hardening)

SHVARTSBURO, M.P., inzh.

Boring precise holes in welded metal structures of truck
cranes. Stroi. i dor.mashinostr. 4 no.6:32-34 Ja '59.
(MIRA 12:8)

(Drilling and boring)

SHVARTSBERG, M.P., inzh.

Use of multiple-purpose adjusting equipment considerably in-
creases the labor productivity. Stroiki dor.mashinostr. no.7:
27-29 J1 '59. (MIRA 12:11)
(Factory management)

SHVARTS BURD, M.P., inzh.

Pneumatic clamps for parts. Mashinostroitel' no.11:19 H '59.
(MIRA 13:3)

(Drilling and boring machinery--Attachments)

CHERNETSKIY, G.I.; SIPITINER, Yu.B.; SHVARTSBURO, M.P.

Readjustable universal pneumatic attachments. Mashinstroitel'
no.8:27 Ag '60. (MIRA 13:9)
(Machine tools--Attachments)

SHVARTSBURO, S.I., uchitel' matematiki 425-y sredney shkoly (Moscow);
GONCHAROV, V.L., professor, redaktor; TSVETKOV, I.L., redaktor;
TYSHEVICH, Z.V., tekhnicheskiy redaktor

[Systems of equations; methodical development of the subject for
a course in algebra for class 8] Sistemy uravnenii; metodicheskaya
razrabotka temy dursa algebry VIII klassa. Pod red. V.L.Goncharova.
Moskva, Izd-vo Akademii pedagog. nauk RSFSR, 1955. 94 p. (MLRA 8:7)
(Equations)

VILENKIN, N.Ya.; SHVARTSBURD, S.I. (Moskva)

Some applications of exponential and logarithmic functions.
Mat. v shkole no.5:9-21 S-0 '59. (MIRA 13:2)
(Functions, Exponential)

VILENKIN, N.Ya.; SHVARTSBURD, S.I. (Moskva)

Problems related to the explanation of exponential and logarithmic
functions. Mat.v shkole no.4:41-43 JI-ig '60. (MIRA 13:9)
(Functions, Exponential)

SHVARTSBUED, S.I. (Moskva)

Experience obtained from work with pupils of the 9th grade studying
to be programmers. Mat. v shkole no.5:9-16 S-0 '60. (MIRA 13:10)
(Mathematics--Study and teaching)

VILENKIN, N.Ya.; SHVARTSBURD, S.I. (Moskva)

Teaching limits of variables and of functions in a secondary school.
Mat. v shkole no.1:24-34 Ja-F '61. (MIRA 14:3)
(Calculus --Study and teaching)

SHVARTS BURD, Boris Isaakovich; SHVARTS BURD, Semen Isaakovich;
UMANSKIY, G.S., red.; MAKHOVA, N.N., tekhn. red.

[Problems in mathematics for schools specializing in machine
building]Zadachi po matematike dlia shkol s mashinostroitel'noi
spetsializatsiei; posobie dlia uchitelei IX-XI klassov. Moskva,
Uchpedgiz, 1962. 93 p. (MIRA 16:1)
(Mathematics--Problems, exercises, etc.)

ASHKINUZE, V.G.; SHVARTSBURO, S.I. (Moskva)

Schools specializing in mathematics. Mat. v shkole no.2:81-83 ~~Mr~~-Ap '63.
(MIRA 1614)

(Mathematics—Study and teaching)

AUTHOR: Shvartsburd, Ye.Ya., Engineer

110-58 -5-12/25

TITLE: The Power Balance and Economic Aspects of Vertical Enamelling Furnaces (Energeticheskiy balans i voprosy ekonomichnosti vertikal'nykh emal'pechey)

PERIODICAL: Vestnik Elektropromyshlennosti, 1958, Vol 29, Nr 5, pp 39 - 41 (USSR).

ABSTRACT: Vertical enamelling furnaces of 15 up to 150 kW are used for wires of diameter 0.07 up to 3 mm or more. Their low efficiency calls for improvement. It is defined as the ratio of the power actually required to dry and polymerise the lacquer to the total input of the furnace. Efficiency figures for various types of enamelling furnaces, when using oil lacquers, are given in Table 1; the values range from 1.5 to 3%.

Wires are enamelled by applying a film of liquid lacquer which is then heated. The heat input to the furnace is partly dissipated with the outgoing hot gas, partly lost through the furnace walls and partly used to heat the wire and lacquer. Energy balances based on this sub-division have been calculated for various types of enamelling furnace; the results are displayed in Table 2. The percentages do not total 100%

Card 1/3

110-58 -5-12/25

The Power Balance and Economic Aspects of Vertical Enamelling Furnaces

because they are referred to the rated power of the furnaces which are in fact regulated: moreover, some of the calculations are approximate.

It will be seen that a large part of the power, on an average 62%, is lost with the discharged gases and the heat lost through the walls averages 25%; only 8% of the power is used to heat the enamelled wires. The furnace efficiency can be reduced by reducing the air movement. The outlet aperture cannot be made too small or else the vibrating wires will touch it during the enamelling process but the amount of air passing through the furnace can be cut down by installing a suitable inlet fan.

If the air-flow is thereby halved, the power consumption of a 70 kW furnace, for example, can be reduced by 19 kW. However, in cutting down the air flow there is a risk of forming explosive mixtures in the equipment. The lower limit of non-explosive concentration for vapours of the solvents formed when enamelling with vinylflex synthetic lacquer is 3% and with oil lacquers (kerosene) 1%. Results of calculations of solvent contents in the atmospheres of different furnaces with reduced air flow are given in Table 3 and it is shown that the normal air flow can be halved without risk of explosion. This

Card2/3

110-58-5-12/25

The Power Balance and Economic Aspects of Vertical Enamelling Furnaces

is clearly a useful way of saving power. Also, the losses through the wall can be cut down by making the furnaces smaller, which is possible because the working chambers are often too big and, in particular, the furnaces should be made as narrow as possible.
There are 3 tables.

ASSOCIATION: NIIKP

SUBMITTED: June 24, 1957

Card 3/3

(N)

L 11629-66

EWT(m)/EWP(t)/EWP(k)/EWP(b)/EWA(a) JD/HW

ACC NR: AP6000939

SOURCE CODE: UR/0286/65/000/022/0012/0012

INVENTOR: Shvartsburd, Ye. Ya.

26

ORG: none

B

TITLE: Method of wire extrusion. Class 7, No. 176229¹⁶

SOURCE: Byulleten' izobreteniy i tovarnykh znakov, no. 22, 1965, 12

TOPIC TAGS: wire, wire extrusion, high pressure extrusion

ABSTRACT: This Author Certificate introduces a method for wire extrusion by pressure transferred by a liquid medium. To make the extrusion process continuous, the high-pressure fluid is forced to move in the direction of extrusion. The friction which is created between the wire rod and the fluid provides the extrusion force. Orig. art. has: 1 figure. [AZ]

18,44.55

SUB CODE: 13/ SUBM DATE: 26Feb63/ ATD PRESS: 477

Card

[Handwritten signature]

UDC: 621.772.2-462.2: 621.7.044

ACCESSION NR: AP4033637

S/0188/64/000/002/0076/0078

AUTHOR: Shvartsburg, A. B.

TITLE: Study of a ring current shielded by a conducting cylinder

SOURCE: Moscow. Universitet. Vestnik. Seriya III. Fizika, astronomiya, no. 2, 1964, 76-78

TOPIC TAGS: ring current, shielded ring current, conducting cylinder, cylindrical current shield, Poisson equation

ABSTRACT: The author assumes that within a hollow cylinder whose radius is a and whose height is $2l$, there is a circular current filament j of radius r_0 whose plane is equally distant from the ends and parallel to them. If it is assumed that the walls of the cylinder are superconducting, the field within the cylinder can be determined by the Poisson equation. After putting this equation into cylindrical coordinates it appears that the field components H_z and H_r are equal to 0 at the boundaries of the cylinder. It is then possible to find an expression for the internal Green's function. From this point a series of formulas leads to derivation of the distribution of H within the cylinder and subsequent computations make it possible to find the potential function of the ring current. Through

Card 1/2

ACCESSION NR: AP4033637

similar calculations the problem of the field of a charged ring within a conducting cylinder can be solved. "The author thanks Academician V. I. Veksler for sustained interest in the study and Yu. N. Lobanov, V. G. Makhan'kov and O. I. Yarkov for valuable discussions." Orig. art. has: 15 formulas.

ASSOCIATION: Nauchno-issledovatel'skiy institut yadernoy fiziki (Scientific Research Institute of Nuclear Physics)

SUBMITTED: 15Apr63

DATE ACQ: 30Apr64

ENCL: 00

SUB CODE: GP

NO REF SOV: 002

OTHER: 001

Card 2/2

I. 12085-46 EWT(1)/ETC(F)/EPP(n)-2/EWO(m) IJP(e) AT

ACC NR: AP5024701

SOURCE CODE: UR/0056/65/049/003/0797/0806

AUTHORS: Tsytoich, V. N.; Shvartsburg, A. B.

61

ORG: Physics Institute im. P. N. Lebedev, Academy of Sciences SSSR
(Fizicheskiy institut Akademii nauk SSSR)

B

TITLE: Contribution to the theory of nonlinear interaction of waves in a magnetoactive anisotropic plasma

SOURCE: Zhurnal eksperimental'noy i teoreticheskoy fiziki, v. 49, no. 3, 1965, 797-806

TOPIC TAGS: magnetoactive plasma, anisotropic plasma, plasma interaction, plasma wave propagation, plasma oscillation, plasma decay

ABSTRACT: A procedure previously used by one of the authors (Tsytoich, with A. Gaylitis, ZhETF v. 46, 1726, 1964 and v. 47, 1469, 1964; also with L. M. Kovrizhnykh, ZhETF v. 46, 1455, 1964) is used to obtain general equations describing nonlinear interaction of waves in an anisotropic plasma both in the presence and in the absence of external magnetic fields. Unlike in earlier papers, the results are not confined to the assumption that the plasma is isotropic even in the case of zero magnetic field, and are therefore suitable for a description of the

Card 1/2

L 12085-66

ACC NR: AP5024701

interaction of waves in a system of interpenetrating plasmas. The results can be used for an analysis of the interaction and nonlinear conversion of non-potential oscillations and waves in a plasma, such as interaction between a plasma and intense high-frequency radiation in the radio and optical bands. Damping is neglected and a procedure for analyzing the interaction of waves having random phases is used. Explicit expressions are derived for the probabilities of scattering of normal waves by plasma electrons and ions and for the probabilities of the decay processes. The equations obtained are limited to a weakly turbulent plasma, and in this approximation the nonlinear effects describe the interaction between waves that satisfy the dispersion relations of the linear theory. Orig. art. has: 31 formulas

SUB CODE: 20/ SUBM DATE: 12Feb65/ NR REF SOV: 018/ OTH REF: 002

Card

2/2

L 20540-66 EWT(d)/EWT(l)/EEC(k)-2/EC(f)/EFF(n)-2/ENG(m)/FCC/ENA(h) IJP(c)

ACC NR: AP6008733 RB/AT/G

SOURCE CODE: UR/0386/66/003/003/0105/0110

AUTHOR: Tsytoich, V. P.; Shvartsburg, A. B.

ORG: Physics Institute im. P. N. Lebedev, Academy of Sciences SSSR (Institut fiziki Akademii nauk SSSR)

TITLE: Nonlinear polarization of radiation passing through a plasma

SOURCE: Zhurnal eksperimental'noy i teoreticheskoy fiziki. Pis'ma v redaktsiyu. Prilozheniye, v. 3, no. 3, 1966, 105-110

TOPIC TAGS: nonlinear plasma, plasma interaction, radio wave propagation, cosmic radiation, cosmic radio source

ABSTRACT: The authors show that nonlinear interaction effects can noticeably alter the polarization of radiation passing through a plasma, if the radiation has sufficient intensity or if its path in the plasma is sufficiently long. The results can be used in investigations of the polarization properties of cosmic radiation, propagation of radio waves, etc. This is done by assuming that the nonlinear effects are weak, expanding the current produced by the wave in the plasma in powers of the wave amplitude, and solving the wave propagation equation by the method of Bogolyubov and Van der Pol, as demonstrated elsewhere (Izv. VUZov, Radiofizika v. 8, 3, 1965). The results are used to analyze the interaction between different polariza-

Card 1/2

78
77
B

2

L 20540-66

ACC NR: AF6008733

tion components of a single monochromatic wave, and the relative rotation of the polarization ellipse and the electric vector. They apply also to the interaction of two waves having different frequencies, where it can be shown that the sum of the energies of the two components of each of the polarizations is conserved. Equations for the mean value of the polarization components are obtained for random interacting waves. It is shown that the interaction of any one wave with any other wave can lead only to a change in the ratio of the intensities of the different polarization components, without changing the total energy of the wave. This characteristic property of the nonlinear interaction in question sharply distinguishes it from other known nonlinear interactions (decay processes and induced scattering) that lead to a change in the spectral composition of the radiation. Another consequence of the calculation is the conservation of entropy (which follows from the conservation of the number of quanta), and consequently reversibility of the nonlinear interactions for random waves. A rough estimate is presented to illustrate the role of the interaction under consideration for the most unfavorable case, when the ellipticity is quite small. For the Crab nebula, for example, with energy densities of 5 ev/cm^3 at a wavelength $\sim 100 \text{ m}$, the ellipticity is found to be $\sim 10^{-3}$. An account of this effect becomes even more important for other radio sources with larger emission density, and also in the case of radio wave propagation in the ionosphere, etc. Orig. art. has: 9 formulas.

SUB CODE: 20/
Card 2/2

SUBM DATE: 25 Nov 65/

ORIG REF: 007/

ACC NR: AP6033428

SOURCE CODE: UR/0057/66/036/010/1896/1900

AUTHOR: Tsytovich, V.N.; Shvartsburg, A.B.

ORG: none

TITLE: On the theory of the excitation and propagation of electromagnetic waves in a weakly turbulent plasma

SOURCE: Zhurnal tekhnicheskoy fiziki, v.36, no. 10, 1966, 1896-1900

TOPIC TAGS: turbulent plasma, plasma diagnostics, plasma stability, double refraction, hydrodynamic theory, perturbation method

ABSTRACT: The authors employ the hydrodynamic equations for the plasma electrons to discuss high frequency perturbations of a weakly turbulent cold plasma. An expression containing terms up to the third degree in the electric field strength is obtained for the current in the plasma. It is assumed that the random electric field due to the turbulence is large compared with the perturbation field, and only terms linear in the latter are retained. A formula is given for the dielectric tensor of a plasma containing both longitudinal and transverse turbulence. The imaginary parts of the dielectric tensor lead to the known decay instabilities. The expression obtained for the increment for quasilongitudinal waves in the presence of transverse turbulence agrees with that obtained in the random phase approximation by V.A. Liperovskiy and V.N. Tsytovich (Preprint FIAN, A-120, 1965) but is valid beyond the limits of appli-

UDC: 533.915.7

Card 1/2

ACC NR: AP6033428

cability of that approximation. New types of instabilities are found, which cannot be described in the random phase approximation. Conditions for the appearance of these instabilities in a plasma containing anisotropic longitudinal or transverse turbulence are found and expressions for their increments are derived. The double refraction of high frequency waves in a plasma containing anisotropic longitudinal turbulence is discussed. The double refraction in a turbulent plasma may prove useful in plasma diagnostics. Orig. art. has: 24 formulas.

SUB CODE: 20

SUBM DATE: 25Feb66

ORIG. REF: 008

OTH REF: 001

Card 2/2

ACC NR: AP6036026 SOURCE CODE: UR/0057/66/036/011/1915/1942

AUTHOR: Tsytovich, V.N.; Shvartsburg, A.B.

ORG: Physics Institute im. P.N. Lebedev, Moscow (Fizicheskiy institut im. P.N. Lebedeva)

TITLE: Nonlinear interaction of waves in a plasma in a strong external magnetic field

SOURCE: Zhurnal tekhnicheskoy fiziki, v. 36, no. 11, 1966, 1915-1942

TOPIC TAGS: nonlinear plasma, turbulent plasma, magnetoactive plasma, plasma

ABSTRACT: The scope of this 27 page treatise on nonlinear interactions of waves in magnetized plasmas is indicated by the following section and subsection headings:
1) Nonlinear interaction; 2) Nonlinear scattering; 3) Induced scattering of high frequency waves on ions, a) Scattering through virtual plasma waves of plasma waves and extraordinary waves into plasma waves and extraordinary waves at the zeroth harmonic; 4) Scattering through plasma waves at the first harmonics; 5) Induced nonlinear scattering of waves on ions through virtual quasitransverse waves; 6) Induced scattering of low frequency plasma waves on ions; 7) Induced scattering of high frequency waves on electrons; 8) Decay processes, a) Decay of plasma waves into low frequency waves, b) Decay of plasma waves into transverse waves and vice versa, d) Decay of transverse waves into transverse waves. The calculations are based on a modification for the case of weakly damped waves in a magnetized plasma under conditions of weak

Card 1/2

ACC NR: APG03G020

space dispersion of the general method developed in a series of papers by A. Gaylitis and V.N. Tsytovich (ZhETF, 46, 1726, 1964; 47, 1468, 1964) and by the present authors (ZhETF, 49, 795, 1965). Three types of waves are discussed: plasma waves, ordinary waves, and extraordinary waves. Under certain conditions the cross section for scattering on ions can exceed that for scattering on electrons. The interaction of waves propagating nearly perpendicularly to the magnetic field can somewhat exceed that of waves propagating parallel to the field. Nonlinear scattering involving virtual waves of different types is discussed and it is shown that induced scattering at the first harmonics of the ion Larmor frequency can exceed that at the zeroth harmonic. The possibility of nonlinear amplification of plasma oscillations at frequencies near the electron cyclotron resonance is discussed. Scattering on ions through virtual quasitransverse waves can exceed that through quasilongitudinal waves; the conditions that this be the case are found, and the induced nonlinear scattering on ions of low frequency plasma waves is discussed. The scattering of waves on the plasma electrons is also discussed. Probabilities are given for a number of decay processes, and equations are presented in an appendix with which probabilities of other decay processes can be calculated. Orig. art. has: 133 formulas, and 5 figures.

SUB CODE: 20 SUBM DATE: 17May65 ORIG. REF: 029 OTH REF: 001

Card 2/2

SHVARTSBERG, G.A. [Shvartsburg, H.A.]; SIVAK, V.I. [Syvak, V.I.]

Improvement of the production of men's trousers. Leh. prom. no.3:
18-19 J1-S '65. (MIRA 18:9)

8(4)
AUTHOR:

Shvartsenau, N. F.

SOV/32-25-2-55/78

TITLE:

Resistance Heating Elements for the Zone Melting Process
(Nagrevateli soprotivleniya dlya zonnogo plavleniya)

PERIODICAL:

Zavodskaya Laboratoriya, 1959, Vol 25, Nr 2, p 232 (USSR)

ABSTRACT:

For the purification of metals and semi-conductors according to the method of zone-recrystallization a thin, powerful heating element is often required consisting of a spiral of heat-resistant alloy in an appropriate case. This case can be manufactured within the plant. A mixture of 30% of heat-resistant alumina and 70% of electro-corundum with a particle size of 80 to approximately 400 mesh is used. The case is manufactured from this mixture and water; it is recommended to bake the crude case at 600° prior to mechanical finishing. After the finishing process the case is baked once more at 1250-1350°, shrinkage amounting to 1.5% at most. Cases produced in this way do not react with the material of the heating element (chrome-nickel, alloy No 2), not even in prolonged operation at temperatures up to 1200°.

Card 1/2

Resistance Heating Elements for the
Zone Melting Process

SOV/32-25-2-55/78

A dismantled heating element of the above-mentioned type is
shown in a figure (Fig). There is 1 figure.

ASSOCIATION: Institut poluprovodnikov Akademii nauk SSSR
(Institute of Semi-Conductors, Academy of Sciences, USSR)

Card 2/2

SHVARTSENAU, N.F.

Purification of tellurium by the zone-melting method. Fiz. tver.
tela 2 no.5:870-873 My '60. (MIRA 13:10)

1. Institut poluprovodnikov AN SSSR, Leningrad.
(Tellurium)

Успенский, Ю.Н., проф; Тимофеева, Т.А.; Шварцман, И.В.

Activity of salivary glands in dogs after a single mass X-irradiation of the abdomen [with summary in English]. Med.rad. 2 no.6:37-41
N-D '57. (MIRA 11:2)

1. Iz kafedry normal'noy fiziologii (zav. - prof. Yu.N.Uspenskiy)
Astrakhanskogo meditsinskogo instituta

(ROENTGEN RAYS, eff.

abdom. irradiation on salivary gland funct. in dogs)

(ABDOMEN, eff. of radiations on

x-irradiation, on salivary gland funct. in dogs)

(SALIVARY GLANDS, physiol.

eff. of x-irradiation of abdom. in dogs)

89669

S/135/61/000/003/006/014
A006/A001

1.2360

AUTHOR: Shvartsen, A. Ya.

TITLE: Building Up With Taper Electrodes

PERIODICAL: Svarechnoye proizvodstvo, 1961, No. 3, pp. 17-19

TEXT: At the Donetsk Polytechnic Institute a new, highly efficient method of building up with taper electrodes was developed. (Author's Certificate No. 124568 with priority from February 21, 1959). The method can be also used for the electro-slag casting of a variety of parts. Figure 1 shows a scheme of the building-up process using a basic shaped electrode, representing a hollow rotary taper whose wall thickness δ is selected depending on the thickness of the built-up layer S : $\delta = S \sin \frac{\alpha}{2}$ where α is the angle at the taper vertex. It is suggested to select δ within 5 to 20 mm. The basic shaped electrode can be employed for the building up of annular or circumferential welds. For the first case a truncated taper is used, for the latter a full taper. The taper electrode is manufactured by casting, press-forming or folding of a sheet. Its shape may be different (Fig. 2). The taper electrode can be very well combined with tubular electrodes of a corresponding section (Fig. 3). The equipment required is simple;

Card 1/6

89669

Building Up With Taper Electrodes

S/135/61/000/003/006/014
A006/A001

X

the A-569, and A-550 machines designed by the Institute of Electric Welding iment Ye. O. Paton or analogous apparatus may be employed. A special machine for building up with taper electrodes is shown in Figure 4. It was designed by the Donetsk Polytechnic Institute, and is equipped with devices for correcting the position of the electrode and of the work piece. Building up can be performed at high current intensities, permitting the building up of 1,200 x 1,200 mm surfaces. The movable carriage is driven by a d-c motor which is fed from an electro-mechanical amplifier. Power supply to the building up device can be brought about by transformers TWC-1000-3 (TSHS-1000-3) or TWC-3000-3 (TSHS-3000-3). The described machine is fed from a single-phase 500 kvamp transformer. Prior to welding, the horizontal position of the work piece must be strictly observed. The electrode is then shortened by a solid electroconductive flux AH-25 (AN-25). AH-8 (AN-8) flux is filled into the taper and placed externally around the electrode tip. The electrode is in a downward position. The process is conducted under electroslag conditions, which can however be altered to arc welding conditions. The main parameters characterizing the process are: the electrode thickness; the angle of conicity; the electrode feed rate; the current intensity; the depth of the slag pool and the voltage on the slag pool. A combined graph (Fig. 6) shows the electrode feed S_p , current intensity (I), voltage (U),

Card 2/6

Building Up With Taper Electrodes

S/135/61/000/003/006/014
A006/A001

power (W) and penetration depth (h_n) when welding an experimental 20 mm thick St.3 steel plate with a 65G steel taper electrode of 7 mm wall thickness. The built up shape is a 200 mm diameter circle. The graph shows that the electrode feed must be variable to assure a more or less constant penetration depth. This is a deficiency of the process. The new method assures high efficiency and produces high coefficients of building-up, attaining up to 50 - 60 g/amp · hr. The quality of the built-up metal is satisfactory. The method can be used for building up various alloyed layers of cast iron, non-ferrous metals and their alloys. During building up with taper electrodes a natural motoring effect is observed promoting the mixing of the built-up metal. The taper electrode makes it possible to build up large areas exceeding its cross section by many times. Simple equipment can be used since only the feed of the electrode is required being its single motion. The author thanks I. I. Frumin, Doctor of Technical Sciences (Institute of Electric Welding imeni Ye. O. Paton) for his assistance as a consultant.

Figure 1:

Schematic drawing of the building-up process with a taper electrode. 1 - taper electrode; 2 - slag pool; 3 - flux; 4 - work piece; 5 - support.

Card 3/6

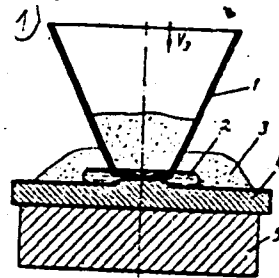

89669

S/135/61/000/003/006/014
A006/A001

Building Up With Taper Electrodes

Figure 2:

Taper electrodes for building up complex-shaped surfaces (a) and rectangular shaped surfaces (b).

Figure 3:

Combined electrodes

Figure 2:

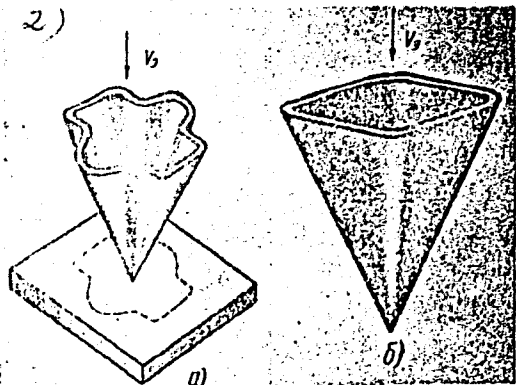

Card 4/6

Figure 3:

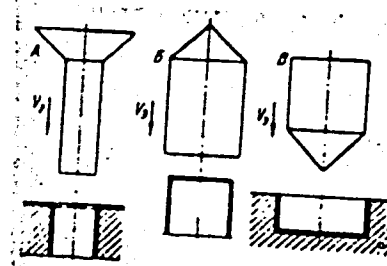

89669

S/135/61/000/003/006/014

A006/A001

Building Up With Taper Electrodes

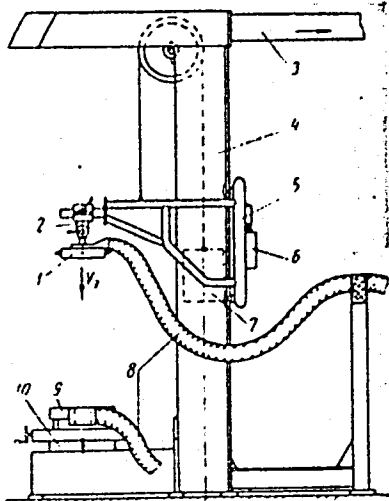

Figure 4:

Machine for building-up with taper electrodes

1 - power connection of electrode; 2 - mechanism of angular correction; 3 - ventilator; 4 - support; 5 - carriage; 6 - reductor with motor; 7 - counterweight; 8 - power supplying cables; 9 - power connection table; 10 - mechanism of linear correction

Card 5/6

89669

S/135/61/000/003/006/014

A006/A001

Building Up With Taper Electrodes

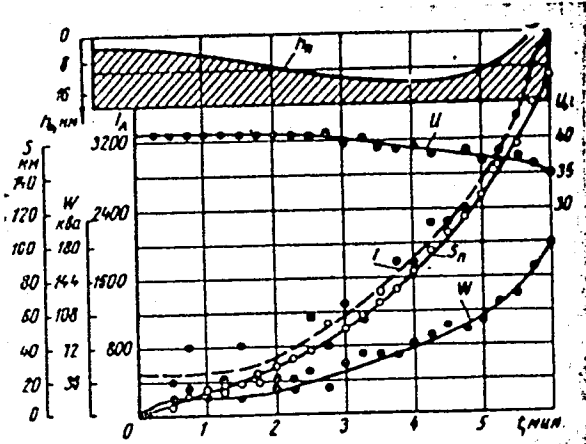

Figure 6:
Combined building-up graph

ASSOCIATION: Donetskij politekhnicheskij institut (Donetskij Polytechnic Institute)

Card 6/6

SHVARTSER, A.Ya.

New method of manufacturing certain types of bimetal tools. Avtom.
svar. 14 no.9:82-84 S '61. (MIRA 14:8)

1. Donetskij politekhnicheskij institut.
(Laminated metals) (Electroforming)

SHVARTSER, A.Ya.; SMOLYANITSKIY, Ya.A.

Equipment for the study of internal stresses in castings being chilled for controlled shrinkage. Izv. vys. ucheb. zav.; chern. met. 5 no.3:196-201 '62. (MIRA 15:5)

1. Donetskij politekhnicheskij institut.
(Founding) (Thermal stresses)

SHVARTSER, A. Ya.; GOLUB, I. Ya.; LUGOVAYA, G. V.

Powder metal lamellar electrodes for electric slag hard facing.
Avtom. svar. 15 no.11:71-76 N '62. (MIRA 15:10)

1. Donetskii politekhnicheskii institut.

(Hard facing) (Metal powder products)

SHVARTSER, A.Ya., inzh.; SHAPOVALOV, S.I., kand.tekhn.nauk; LUGOVAYA, G.V.,
inzh.; GLAZUNOV, F.A., inzh.; TKACHENKO, V.A., inzh.; MOZNAIM,
G.I., inzh.

Electric slag hard facing of beaters in impact-action crushing
machines. Svar. proizv. no.3:22-25 Mr '63. (MIRA 16:3)

1. Donetskii politekhnicheskii institut (for Lugovaya).
2. Yasinovatskiy mashinostroitel'nyy zavod (for Moznaim).
(Hard facing) (Crushing machines)

SHVARTS-ER, A.Ya., inst.

Device for recording the deformations of a specimen. Svar.
proizv. no. 3:12-13 S '64. (MIRA 17-12)

L. Donetskij politekhnicheskij institut.

L 32458-65 EWT(m)/EWP(v)/T/EWP(t)/EWP(k)/EWP(b) Pf-4 JD/HM

ACCESSION NR: AP4049515

S/0125/64/000/011/0022/0027

AUTHOR: Shvartser, A. Ya. (Candidate of technical sciences); Morozov, Yu. D. (engineer)

TITLE: Electroslag welding process with a free forming of the filler metal

SOURCE: Avtomaticeskaya svarka, no. 11, 1964, 22-27

TOPIC TAGS: horizontal weld, electrode slip, tapered electrode, circular heat source

ABSTRACT: Horizontal electroslag welding has been considered impossible but may be carried out by various methods. Whatever the method employed, the electrode slip should also occur either in transverse or in longitudinal direction. A tapered electrode makes the surfacing of differently shaped areas possible using a vertical electrode travel only. In approximation the heat source may be assumed to be as linear, circular and with a continuously increasing diameter. Inside such circular heat source a characteristic cooling process takes place. There are no thermal flows in radial direction. The crystallization of the hot metal occurs only from the bottom upward and the process sets in only after energy is

Card 1/2

20
18
B

L 32458-65

ACCESSION NR: AP4049515

2

disconnected. Thus, the filler metal remains liquid until welding is completed. Furthermore, a free spreading of the filler metal along the horizontal surface of the part takes place. The hot metal wets the surface being built up. The authors succeeded in eliminating the defects which characterize imperfect fusion by investigating the laws that govern the spreading of the hot metal in the electric slag welding on a horizontal surface. The free forming of the filler layer and the observation of the rules of feeding electrode metal to the pool secure high-quality welds. Care should be taken to provide for transverse wire electrode vibrations to occur along a curve that corresponds to the outline of the freely spreading edge of the layer. When cylindrical electrode is used its edge should follow the shape of the edge of the built-up layer so that the zone in which the drop of the electrode metal occurs, coincides with the edge of that layer. The rate of electrode feeding should always conform to the rate of surfacing. The advantage of the method is that it assures a fine surfaced layer, while the productivity of the process is high. Orig. art. has: 7 figures and 4 equations.

ASSOCIATION: Donetskiy politekhnicheskij institut (Donets Polytechnic Institute)

SUBMITTED: 17Mar64

ENCL: 00

SUB CODE: MM

NR REF SOV: 005

OTHER: 000

Card 2/2

SHAPOVALOV, S.I., kand. tekhn. nauk; FOLCHAREVSKIY, D.B., inzh.; SHVARTSER,
A.Ya., kand. tekhn. nauk

Preventing the separation of the facing layer from the base
metal in electric slag hard facing of high-manganese on low-
carbon steels. Svar. proizvod. no.6:3-5 Ja '65. (MFA 18:8)

1. Donetskii politekhnicheskii institut.

ACC NR: AP6035711 (N) SOURCE CODE: UR/0413/66/000/019/0058/0058

INVENTOR: Zolotarevskiy, D. B.; Shvarts'er, A. Ya.

ORG: none

TITLE: Interlayer for joining low-carbon steel to high-manganese steel. Class 21, No. 186584

SOURCE: Izobreteniya, promyshlennyye obraztsy, tovarnyye znaki, no. 19, 1966, 58

TOPIC TAGS: metal joining, metal welding, high manganese steel welding, ~~disimilar~~ steel welding, metal bonding, manganese steel, low carbon steel

ABSTRACT: This Author Certificate introduces an interlayer, containing carbon, manganese, silicon and phosphorus, for facilitating the joining of low-carbon steel to high-manganese steel. To increase the joint strength of the bond and to prevent a cleavage in deposited metal, the composition of the interlayer is set as follows: 0.75—0.85% molybdenum, 0.45—0.6% tungsten, 0.5% max manganese, 0.08% max carbon, 0.1% max silicon and 0.03% max phosphorus.

SUB CODE: 13/1/SUBM DATE: 09Jul65/

Card 1/1

UDC: 621.791.042

SHVARTSER, Boris Vol'fovich; DZEVUL'SKIY, V.A., kand. tekhn. nauk, dots.; red.; LAVRENT'YEV, M.V., kand. tekhn. nauk, dots., red.; MIRONETS, Ye.M., red.

[Collection of problems on the fundamentals of heat engineering and hydraulics] Sbornik zadach po osnovam teplotekhniki i gidravliki. Kiev, Izd-vo Kievskogo univ., 1965. 81 p. (MIRA 18:4)

L 60361-65 EWA(h)/EWP(k)/EWT(d)/EWT(l)/EWP(h)/ETC(m)/EEG(m)/EWA(d)/EWP(l)/EWP(v)
PF-l/PI-l/PO-l/PG-l/PEB WW
ACCESSION NR: AP5019057

UR/0286/65/000/012/0085/0085
681.121

AUTHORS: Podgoyetskiy, M. L.; Shvartsaer, V. I.; Sheynkerman, E. Z.; Shvartsaer, L. I.; Turina, M. A.; Fateyeva, N. V.

TITLE: Pneumatic flow meter, Class 42, No. 172074

123

SOURCE: Byulleten' izobreteniy i tovarnykh znakov, no. 12, 1965, 85

TOPIC TAGS: flow meter,¹⁴ pneumatic device

ABSTRACT: This Author Certificate presents a pneumatic flow meter containing a measuring unit and a pneumatic transducer. To increase the accuracy of measurement, the sensitive unit of the measuring unit is in the form of a membrane. The membrane is provided with a constricting device, e.g., a throttle, which is kinematically coupled by a system of levers to a compensation unit (see Fig. 1 on the Enclosure). To eliminate natural vibrations and to obtain zero compensation, an integrating regulator is included in the feedback channel. Orig. art. has: 1 diagram.

ASSOCIATION: Konstruktorskoye byuro "Tsvetmetavtomatika" pri gosudarstvennom komitete tyazhelogo energeticheskogo transportnogo mashinostroyeniya pri gosplane, SSSR (Construction Bureau "Automatic Equipment for Nonferrous Metals" for the State Committee of Heavy Power Transport Machine Construction for Gosplan, SSSR)

Card 1/3

I 60361-65

0

ACCESSION NR: AP5019057

SUBMITTED: 20May63

NO REF SOV: 000

ENCL: 01

OTHER: 000

SUB CODE: IE

Card 2/3

L 60361-65

ACCESSION NR: AP5019057

ENCLOSURE: 01

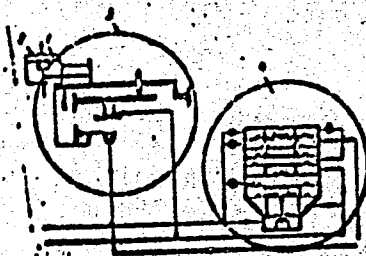

Fig. 1.
1- membrane; 2- constricting device; 3- compensation unit;
4- integrating regulator

Card

SC
3/3

Leads Nelson, Heron
10/1/77

3128. The reconstruction of the gas producer in the silicon brick works at Karia Marhan.—M. A. SHVARTS (Ognepoy, 18, 419, 1948). Dimensional diagrams show the gas producer and analyses are given of the gas produced. (5 figs., 1 table.)

Dec 52

SHVARTSER, M. A.

USSR/Engineering - Refractories, Kilns

"On the Layout of Automatic Temperature Regulation in a Tunnel Kiln for Burning Chrome-Magnesite Products," M. A. Shvartser, V. I. Ivanovskiy, Engrs

Ogneupory, No 12, pp 534-540

Discusses automatic temp control system installed on exptl basis for one of tunnel kilns at Karl Marx Plant in 1951. Though facilitating operation of kiln and decreasing fuel consumption, system, according to authors, has number of defects which are analyzed, suggestions are given for eliminating them in future designs.

267T66

S/131/60/000/06/02/012
B015/B007AUTHORS: Antonov, G. I., Minkovich, B. D., Shvartser, M. A.,
Shakhov, G. S., Semenov, I. N., Khil'ko, M. M.,
Molchanova, M. I.TITLE: Production and Practical Testing of Burned and Unburned
Small-size Forsterite Bricks ✓

PERIODICAL: Ogneupory, 1960, No. 6, pp. 244-251

TEXT: A. S. Frenkel', Ukrainskiy nauchno-issledovatel'skiy institut
ogneuporov (Ukrainian Scientific Research Institute of Fireproof Materials)
recommended measures for the purpose of increasing the production of re-
fractory regenerator forsterite bricks as well as for the simultaneous
reduction of their actual costs. This may be brought about by using unburn-
ed small-size bricks. For the purpose of checking these measures, the
Panteleymonovskiy ogneuporny zavod (Panteleymonovka Works of Fireproof Ma-
terials) together with the Ukrainian Scientific Research Institute of Fire-
proof Materials in 1957 produced industrial batches of burned and unburned
small-size forsterite bricks. S. B. Vinokur, N. S. Mitrokhina, and B. A. ✓

Card 1/3

Production and Practical Testing of Burned
and Unburned Small-size Forsterite Bricks

S/131/60/000/06/02/012
B015/B007

Faynerman (Footnote p. 245) took part in this work. The chemical composition of the ground powders may be seen from Table 1, the characteristics of the pastes and blanks from Table 2, and the properties of the burned and unburned products from Table 3. The burned small-size forsterite bricks corresponded to 4МТV 5127-55 (ChMTU 5127-55) and were not inferior to bricks of normal size. Fig. 1 shows the checkerwork of a regenerator made from small-size bricks. Experiments with these bricks were carried out at the zavod im. Kirova (Works imeni Kirov). The characteristics and mineralogical composition of the burned small-size forsterite bricks after their use are given in Tables 4 and 5. Table 6 shows the results of a furnace campaign, and Fig. 2 the temperature course of the regenerator. Figs. 3 and 4 show unburned forsterite bricks after being used, and Table 6 and Fig. 5 show the operational conditions of furnaces. Tables 7 and 8 give the characteristics and the mineralogical composition of unburned small-size forsterite bricks after use. Petrographical investigations were carried out by L. I. Karyakin (Ref. 2). By way of a summary, the authors declare that burned small-size bricks are in no way inferior to standard-size bricks. By the use of 50-60% of unburned bricks in furnace construction, the production of refractory forsterite bricks for generators may

Card 2/3

Production and Practical Testing of Burned
and Unburned Small-size Forsterite Bricks

S/131/60/000/06/02/012
B015/B007

be increased and their actual costs may be reduced by roughly 25%.
There are 5 figures, and 8 tables.

ASSOCIATION: Ukrainskiy nauchno-issledovatel'skiy institut ogneuporov
(Ukrainian Scientific Research Institute of Fireproof
Materials) Antonov, G. I., Minkovich, B. D.;
Panteleymonovskiy ogneupornyy zavod im. K. Marksa
(Panteleymonovka Works of Fireproof Materials imeni K. Marx)
Shvartser, M. A., Shakhov, G. S., Semenov, I. N.;
Makeyevskiy metallurgicheskiy zavod im. Kirova (Makeyevka
Metallurgical Plant imeni Kirov) Khil'ko, M. M., Molchanova,
M. I.

Card 3/3

ARKAD'YEV, A.G.; MAR'YANOVSKIY, Ya.M.; PODGOYETSKIY, M.L.; SHVARTSER,
V.I.; SHNEYEROV, M.S.

Air-jet reaction feedback in pneumatic converters with power
compensation. Priborostreenie no.2:5-7 F '61. (MIRA 14:2)
(Pneumatic control)

L 60361-65 EWA(h)/EWP(k)/EWT(d)/EWT(l)/EWP(h)/ETC(m)/EEC(m)/EWA(d)/EWP(l)/EWP(v)
Pf-l/Pl-l/Po-l/Pq-l/Ps-l/Peb WW
ACCESSION NR: AP5019057

UR/0286/65/000/012/0085/0085
681.121

AUTHORS: Podgoyetskiy, M. L.; Shvartser, V. I.; Sheynkerman, E. Z.; Shvartser, L. I.; Turina, M. A.; Fateyeva, N. V.

TITLE: Pneumatic flow meter. Class 42, No. 172074

SOURCE: Byulleten' izobreteniy i tovarnykh znakov, no. 12, 1965, 85

TOPIC TAGS: flow meter,¹⁴ pneumatic device

ABSTRACT: This Author Certificate presents a pneumatic flow meter containing a measuring unit and a pneumatic transducer. To increase the accuracy of measurement, the sensitive unit of the measuring unit is in the form of a membrane. The membrane is provided with a constricting device, e.g., a throttle, which is kinematically coupled by a system of levers to a compensation unit (see Fig. 1 on the Enclosure). To eliminate natural vibrations and to obtain zero compensation, an integrating regulator is included in the feedback channel. Orig. art. has: 1 diagram.

ASSOCIATION: Konstruktorskoye byuro "Tsvetmetavtomatika" pri gosudarstvennom komitete tyazhelogo energeticheskogo transportnogo mashinostroyeniya pri gosplane, SSSR (Construction Bureau "Automatic Equipment for Nonferrous Metals" for the State Committee of Heavy Power Transport Machine Construction for Gosplan, SSSR)
Card 1/3

I 60361-65

ACCESSION NR: AP5019057

SUBMITTED: 20May63

ENCL: 01

SUB CODE: IE

NO REF SOV: 000

OTHER: 000

Card 2/3

L 60361-65

ACCESSION NR: AP5019057

ENCLOSURE: 01

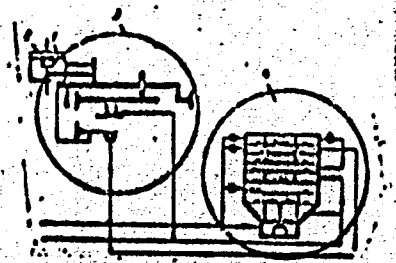

Fig. 1.

1- membrane; 2- constricting device; 3- compensation unit;
4- integrating regulator

Card

SC
3/3

SHVARTSEV, S.L.

Underground waters in the Yenisey Valley of the Siberian Plat-
form. Mat. Kom. po izuch. podzem. vod. Sib. i Dal' Vost. no.2:
90-100 '62. (MIRA 17:8)

UDODOV, P.A.; RASSKAZOV, N.M.; SHVARTSEV, S.L.

Plan of the regionalization of Siberia for purposes of hydrogeological prospecting for ore deposits. Geol. i geofiz. no.11:95-97 '62.
(MIRA 16:3)

1. Tomskiy politekhnicheskiy institut i Sibirskiy nauchno-issledovatel'skiy institut geologii, geofiziki i mineral'nogo syr'ya.
(Siberia--Geochemical prospecting) (Siberia--Ore deposits)

SHVARTSEV, S.L.

Some results of hydrochemical studies under permafrost conditions. Geol. rud. mestorozh. 5 no.2:100-110 ~~Mr~~-Ap '63.
(MIRA 16:6)

1. Sibirskiy nauchno-issledovatel'skiy institut geologii, geofiziki i mineral'nogo syr'ya, Novosibirsk.
(Siberian Platform—Frozen ground)
(Water, Underground)

KONTOROVICH, A.E.; SADIKOV, M.A.; SHVARTSEV, S.L.

Distribution of some chemical elements in surface and subsoil waters of the northwestern part of the Siberian Platform.
Dokl.AN SSSR 149 no.1:179-180 Mr '63. (MIRA 16:2)

1. Sibirskiy nauchno-issledovatel'skiy institut geologii, geofiziki i mineral'nogo syr'ya. Predstavleno akademikom N.M.Strakhovym.

(Siberian Platform—Chemicals)
(Siberian Platform—Water—Analysis)

UDODOV, P.A.; ROGOV, G.M.; RASSKAZOV, N.M.; SHVARTSEV, S.L.; LUKIN, A.A.

Concerning E.K. Beliakova's article "Principles and methods of
compiling prognostic hydrochemical maps of ore deposits."
Sov. geol. 6 no.10:154-157 0 '63. (MIRA 17:1)

1. Tomskiy politekhnicheskii institut i Sibirskiy nauchno-issledo-
vatel'skiy institut geologii, geofiziki i mineral'nogo syr'ya.

SHVARTS, I. I.

Hydrogeochemical prospecting method in the northern swamped
regions. Geol. i geofiz. No. 7:3-10 '65. (MIRA 18:9)

1. Nauchno-issledovatel'skogo
instituta geologii, geofiziki i mineral'nogo syr'ya, Tomsk.

OLEYNIKOV, B.V.; SHVARTSEV, S.L.; MANDRIKOVA, N.T.; OLEYNIKOVA, N.N.

Nickel hexahydrate, a new mineral. Zap.Vses.min.ob-va 94
no.5 534-547 '65. (MIRA 18:11)

1. Sibirskiy nauchno-issledovatel'skiy institut geologii,
geofiziki i mineral'nogo syr'ya, Novosibirsk.

S/118/60/000/011/004/014
A161/A133

AUTHORS: Tikhanovskaya, G.Ya., and Shvartsgorn, M.A., Engineers
TITLE: Automatic removal of defective metal in cutting machines
PERIODICAL: Mekhanizatsiya i avtomatizatsiya proizvodstva, no. 11, 1960,
11-15

TEXT: Detailed information is given on the design and operation of a new reject-eliminating sorting system installed at drum shears in the sheet rolling shop of the Magnitogorskiy metallurgicheskiy kombinat, or MMK (Magnitogorsk Metallurgical Combine). The system has been developed by the Tsentral'naya zavodskaya laboratoriya avtomatizatsii proizvodstva (Central Plant Laboratory for Automation of Production) of the MMK. At the time being, 25.6% of the labor in the MMK rolling shops are occupied with sorting marking, straightening, cutting and packaging of metal. The system (Fig.1) includes a photoelectric НПП -455 (NPP-455) defectoscope revealing cuts, pierced holes, rolled-in crumbs, etc., and a radioactive ИТУ -495 (ITU-495) micrometer detecting thickness variations. Signals caused by a hole or off-standard thickness are amplified and fed to the communicator unit pro-

Card 1/6

Automatic removal of defective metal ...

S/118/60/000/011/004/014
A161/A133

ducing a command signal to the automatic control system of the first conveyer section after the shears. The conveyer section goes down, and the rejected sheet goes into the reject pocket. The radioactive micrometer uses a strontium isotope with 20 years half-life and performs continuous non-contact measurement in 0.03-0.7 mm sheets. As it does not signal deviations from gage beyond the tolerance limits, it has been fitted with an electronic attachment for setting thickness tolerances. The photoelectric NPP-455 defectoscope is separately illustrated in a block diagram (Fig.2). The electronic "thickness setter" (Fig.3) has two analogous channels. Its measuring system is a double bridge including the free rheochord of the indicating micrometer instrument ($R_{\text{прод}}$), two wire-wound alternating resistors (R_{max} and R_{min}) and additional resistors R_1, R_2, R_3 and R_4 ; the maximum and minimum tolerance are set with sliders. The automatic reject eliminating system exists in two modifications: the simple first one, including electromagnetic relays with constant time delay for lowering and lifting the first conveyer section, and used on two shears in the shop, and a more complex one on a third shears. The simpler system dependably detects and catches defective

Card 2/6

Automatic removal of defective metal ...

S/118/60/000/011/004/014
A161/A133

sheets but does not reliably single them out, and several good sheets (4-5) go together with the spoiled ones into the reject pocket. Besides, the lowering or sinking of the conveyer section can start at any moment regardless of the position of the sheets on the conveyer, and good sheets may be jammed and spoiled. The more complex system is free of these faults. It includes a block of electronic relays (ЭЭР), an automatic panel, a program switch for the sheet length, and a photo-head $\Gamma 1$ (placed directly behind the flying shears). The article includes a detailed description of the functions of every element in the system. The automatic sorting has replaced 70 men, raised the average work productivity in the shop by 4.5%. There are 7 figures.

Card 3/6

S/118/60/000/011/004/014
A161/A133

Automatic removal of defective metal ...

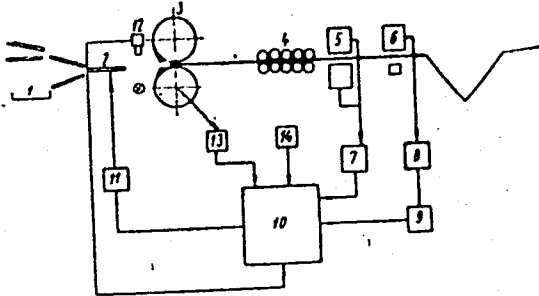

Fig. 1 - 1-reject pocket; 2-first conveyer section; 3-drum shears; 4 - straightening machine; 5-photoelectric NPP-455 defectoscope; 6-radioactive ITU-495 micrometer; 7-defectoscope amplifier; 8-micrometer amplifier; 9 - electronic thickness setting device; 10-communicator unit; 11-automatic control of the first conveyer section; 12-pickup (synchronizing relay) of sheets position; 13-tachometer generator; 14-pickup of sheets length.

Card 4/6

Automatic removal of defective metal ...

S/118/60/000/011/004/014
A161/A133



Рис. 2. Схема дефектоскопа НПП-455:

- 1 — линейный источник света;
- 2 — фотоприемник светового излучения;
- 3 — контролируемая полоса;
- 4 — блок усиления и формирования импульсов подсвечивания.

Сигнал на разбражку

Fig. 2 - The NPP-455 defectoscope. 1-linear light source; 2-photo-receiver; 3-the inspected sheet; 4-amplifying and light pulse forming unit.

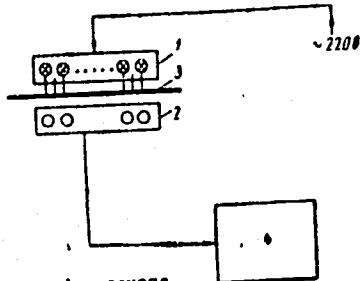
Card 5/6

Automatic removal of defective metal ...

S/118/60/000/011/004/014
A161/A133 ✓

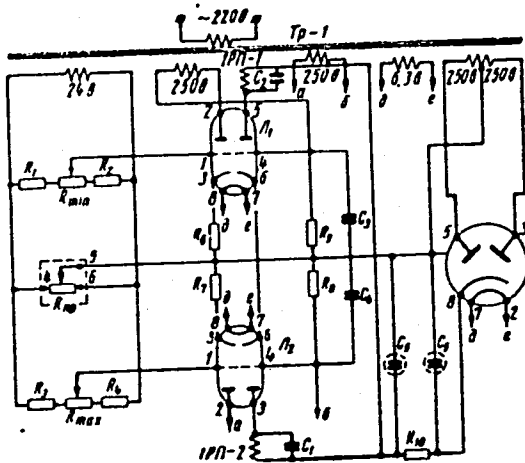

Fig. 3 - Electronic thickness tolerance regulator.

Card 6/6

S/118/60/000/012/0001
A161/A033

AUTHORS: Kozhevnikov, V.V., and Shvartsgorn, M.A., Engineers

TITLE: Automatic Seam Detection in Steel Strip

PERIODICAL: Mekhanizatsiya i avtomatizatsiya proizvodstva, 1960, No. 12, pp. 7-8

TEXT: Two continuous sheet cold-rolling mills in the rolling shop No. 3 of the Magnitogorskiy metallurgicheskiy kombinat (Magnitogorsk Metallurgical Combine) are rolling sheet from 2.2 mm strip hot-rolled from 3-ton slabs; 3-ton strips are being joined by butt-welding during pickling (or cleaning) into 15-ton coils. The mill must be slowed down to pass a seam for otherwise the strip may get torn apart and the rolls scarred. At present the mill operators have to watch, and they tend to decelerate too early and sometimes miss a seam despite this. The Automation Laboratory of the Combine has designed an instrument with a light source and two photo-heads that detects the seam at the right moment and decelerates the mill with a time delay. The seams are marked by paint. The instrument is placed in front

rd 1/6

S/118/60/000/012/002/009
A161/A033

Automatic Seam Detection in Steel Strip

state. The capacitor-charging time determines the relay operation time, and the charging time depends on the tachometer generator voltage that is proportional to the work rolls velocity. The PE contact closes after the passing of a seam, and negative voltage goes to the tube grid, and the trigger returns into stable state. There are 3 figures.

✓

Card 3/6

S/118/60/000/012/002/009
A161/A033

Automatic Seam Detection in Steel Strip

Fig. 2

- 1 - Comparison unit;
- 2 - amplifier photo-relay;
- 3 - electronic time relay;
- 4 - photo-heads.

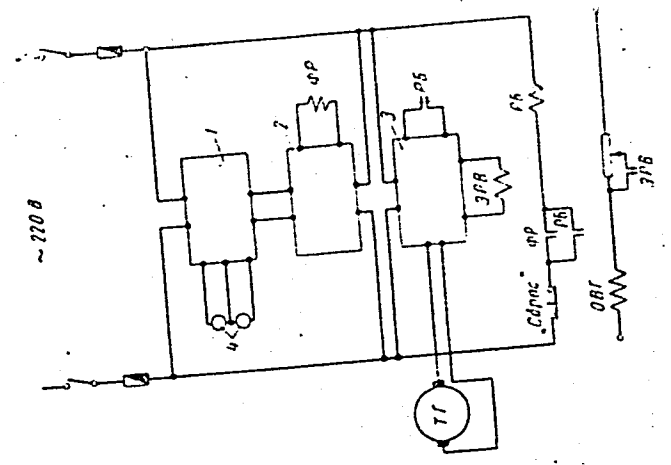

Card 5/6

Automatic Seam Detection in Steel Strip

S/118/60/000/012/002/009
A161/A033

Fig. 3 : Electronic time relay circuit.

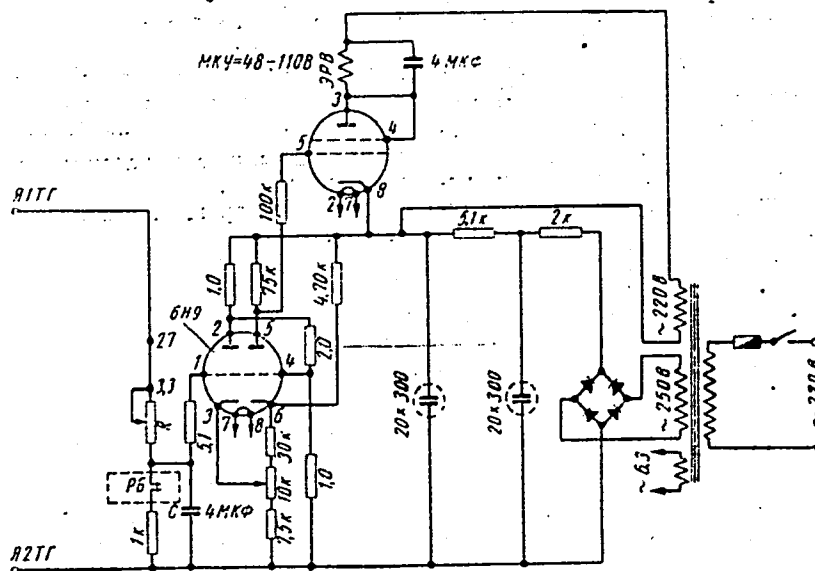

Card 6/6

TIKOTSKIY, A.Ye., inzh.; SHVARTSGORN, M.A., inzh.

Command-transfer length meter for the control of flying shears.
Mekh. i avtom.proizv. 15 no.12:31-33 D '61. (MIRA 14:12)
(Shear (Mechanics))

SHVARTSKOPF, M. K.

Vorobin, N. N. and Shvartskopf, M. K. "Zinc-coating of
copper wires and copper cable in a sodium zincate solution
Investiya Khim. tekhn. politekhn. in-ta, Vol VIII, 1968 (on
cover: 1969), p. 157-58

SO: U-5241, 17 December 1963, (Leto is 'Zhurnal Inzh. State, no. 26, 1963)

SHVARTSKROYN B.M.

FISHER, P.N.; KEYL', I.A.; VOROB'YEVA, G.I.; SHVARTSKROYN, B.M.; ALYAMOVSKAYA,
T.S.; ZYBIN, S.Ye.; DRUZHININA, A.T.; SHILOV, Yu.P.

Growing yeast on hydrolysates from coniferous wood. Gidroliz.
i lesokhim. prom. 16 no.5:7-12 '63. (MIRA 17:2)

1. Moskovskoye otdeleniye Gosudarstvennogo nauchno-issledovatel'skogo instituta gidroliznoy i sul'fitno-spirtovoy promyshlennosti (for Fisher, Keyl', Vorob'yeva, Shvartskroyn, Alyamovskaya).
2. Ivdel'skiy gidroliznyy zavod (for Zybin, Druzhinina, Shilov).

GROMOVOY, E., kand. tekhn. nauk, ispolnyayushchiy obyazannosti dotsenta;
SHVARTSMAN, A., kand. fiz.-matem.nauk, dotsent

Planning the storage of cargo with a view to maximum profits. Mor.
flot 25 no.7:13-15 J1 '65. (MIRA 18:7)

1. Odesskiy institut inzhenerov morskogo flota.

SZWARCHMAN, A.A. [Shvartsman, A.A.]

Development of electric traction as underground transportation
in U.S.S.R. mines. Pt. 2. Wiadom gorn 11 no. 1/2:3-7 Ja-F '60.

AUTHOR: Shvartsman, A.A., Engineer SOV-127-58-3-14/24

TITLE: New Electric Locomotives for Underground Mining (Novyye elektrozvozy dlya podzemnykh gornykh rabot)

PERIODICAL: Gornyy zhurnal, 1958, Nr 3, pp 63-69 (USSR)

ABSTRACT: As a result of a collaboration of Aleksandrovskiy i Toretskiy mashinostroitel'nyye zavody (The Aleksandrovskiy and Toretskiy Mashine Building Plants) with Moskovskiy zavod "Dinamo" (The Moscow Plant "Dynamo") and Khar'kovskiy elektroyagovyy zavod KhETZ (The Kharkov Electric Locomotive Plant KhETZ) new models of electric locomotives for underground mining works were manufactured. A serial production of contact wire locomotive 7KR-1, 10 KR-1 and 14 KR-1 started in 1957. These types are the improved models of the earlier 7KR, 10KR, 14KR and 14 KKM. By 1958, production of series KR-2 will be taken up. It has the same traction characteristics but has a spring frame suspension and a pneumatic system. The locomotives of the KR-1 series have a traction coefficient of 0.23. The 7KR-1 and 10KR-1 locomotives are driven by two EDR-25 motors, total power 50 kw/h. The Aleksandrovskiy Plant also manufactures the battery operated 12 t locomotive 12 ARP-1, also equipped with two EDR-25 motors. The same plant pre-

Card 1/2

New Electric Locomotives for Underground Mining

SOV-127-58-3-14/24

pers for production especially powerful contact wire electric locomotives 20KR-1 and coupled battery operated 24 t locomotives 24ARP-1. A description of all of these types is given. The author complains of considerable delay in the production by the KHETE of the motors EDR-25 which delayed the production of KR-1 locomotives by two years. The "Dynamo" also delayed the production of the 14 KR-1 locomotives. As a result of the belated production of ordered motors, the first locomotives produced of the 12ARP-1 type were equipped with the EDR-15 motors instead of EDR-25. As a consequence, the traction power of these locomotives was reduced. The production of powerful 20 t locomotives was also considerably delayed. The author finds that the intervention of competent authorities is necessary to improve coordination between machine building and electrical industries. There are 4 figures, 3 tables and 2 diagrams.

ASSOCIATION: Permskiy gornyy institut (The Perm Mining Institute)

1. Locomotives---Design
2. Locomotives---Production
3. Electric motors---Performance
4. Mining equipment

Card 2/2

AUTHOR: Shvartsman, A.A., Engineer SOV-118-58-9-18/19

TITLE: Bibliography - Mining Transportation Abroad (Bibliografiya - Rudnichnyy transport za rubezhom)

PERIODICAL: Mekhanizatsiya trudoyemkikh i tyazhelykh rabot, 1958, Nr 9, pp 45-46 (USSR)

ABSTRACT: A joint team, headed by A.O. Spivakovskiy, **Corresponding Member** of the USSR Academy of Sciences, has composed a book on mining transportation abroad. The following authors are participants: N.D. Samoylyuk, O.V. Mukhin, G.I. Solod, I.F. Goncharevich, A.Ye. Smoldyrev, V.G. Shorin, B.G. Gorbachev, L.G. Medvedev, and A.V. Yevnevich. The book is recommended for use.

1. Transportation 2. Mines--Transportation

Card 1/1