

THE DRIFT OF SMALL-SCALE IRREGULARITIES IN THE IONOSPHERE
(according to measurements at Irkutsk)

by

V. D. Kokourov and E. S. Kazimirovskii

1. INTRODUCTION

An experimental device to investigate horizontal movements in the ionosphere was built in accordance with the IGY program at the ionospheric laboratory of the Irkutsk Magnetic-Ionospheric Station of the East Siberian branch of the Academy of Sciences USSR. From April 1958, regular observations of the drift of the small scale irregularities in the ionosphere were initiated by the method of spaced reception with a small base. The observations were carried out according to the program of the IGY and of the additional instructions for the Soviet Union stations [1,2].

This article gives the results of the observations for the period from 1 April 1958 through 30 October 1959.

2. APPARATUS

A manually-operated ionosonde with transmitting, receiving and recording equipment [4] is used to study the drift of the small-scale irregularities in the ionosphere. The frequency range is 1.5-16.0 mc, the power, of the order of 20 kv in an impulse with a 100 micro-sec duration, a frequency repetition of 50 cycles. A sectionalized rhombic vertical antenna with a 700 ohm load resistance was used for the emission. A VS-342 receiver adapted for impulse reception was used to receive reflected signals. The transmission band was of the order of 200 kHz and the amplification factor was $5 \cdot 10^6$. The receiving antennas were asymmetrical dipoles, which are strictly oriented

parallel to each other along the 110° azimuth, located at the vertices of an equilateral triangle with the legs, 120 m lying in a NS and EW direction. The receiving antennas, using a high-frequency RK-1 coaxial cable installed under the ground, are connected with the antenna switch, which alternately connects them to the same receiver. The amplitude of the signal received from the oscillograph screen with a three-track scan is photographed on 35 mm film with an advance rate of 14.6 cm/min. Figure 1 gives a block-diagram of the set up.

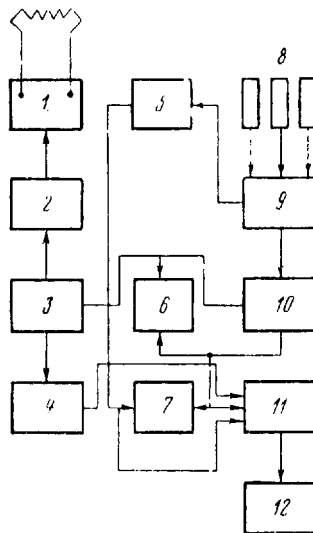

Fig. 1. A block-diagram of the set up for investigating the drift of the small scale irregularities in the ionosphere.

- 1- the transmitter, 2- modulator, 3- timer, 4- height marks, 5- receiver, 6- sweep generator, 7- monitoring oscillograph, 8- receiver antennas, 9- antenna switch, 10- sweep forming unit, 11 and 12- recording unit.

Approved For Release 2001/03/26 : CIA-RDP96-00787R000500130079-9

THE DRIFT OF SMALL-SCALE IRREGULARITIES IN THE IONOSPHERE (CONT'D)

3. OBSERVATIONAL RESULTS

The horizontal movements in the E and F2 regions of the ionosphere were studied. The method of measurements is based on a study and comparison of the nature of the behavior of the unit signals reflected from the ionosphere and taken at three scattered points. The observations were made on frequencies of 2.1 ± 0.1 mc hourly on Regular World Days, Special World Intervals and Regular World Intervals and on the additional 3-4 days recommended for the Soviet Union stations. The duration of the session was 5 minutes in the interval from 00 to 08 minutes every hour.

The magnitude of the velocity and direction of the drift of the small scale irregularities were determined from the mean time shifts of the usual parts of the recordings of the fadings [1,2]. Processing by this method yields approximately 30-40% of all recordings. A series of observational sessions were eliminated from the processing due to strong radio-interference, considerable absorption or because of the presence of large diffusion in the ionosphere. Recordings of fadings were obtained with a high degree of similarity, slight similarity and they were random. For the most part the fadings were of a periodic or quasi-periodic nature with a 0.1-5.0 second period. The angle determining the direction of movement is read clockwise. It should be noted that the method we use, generally speaking, does not give a well-defined determination of the height at which the actual drift occurs. However, there is basis to assume that in the case of measuring drifts from the echoes from the E layer during the day and from the F2 layer at night (with the absence of random E at this time) the measurement data can pertain to the corresponding layer.

Figure 2 gives histograms of the magnitudes of the velocities and directions of drift of the small scale irregularities in the F2 layer. It is evident from these histograms that the drift velocity lies within the limits 20-200 m/sec, whereupon the most probable value of the velocity is 60-80 m/sec. The principal direction is (270-300°).

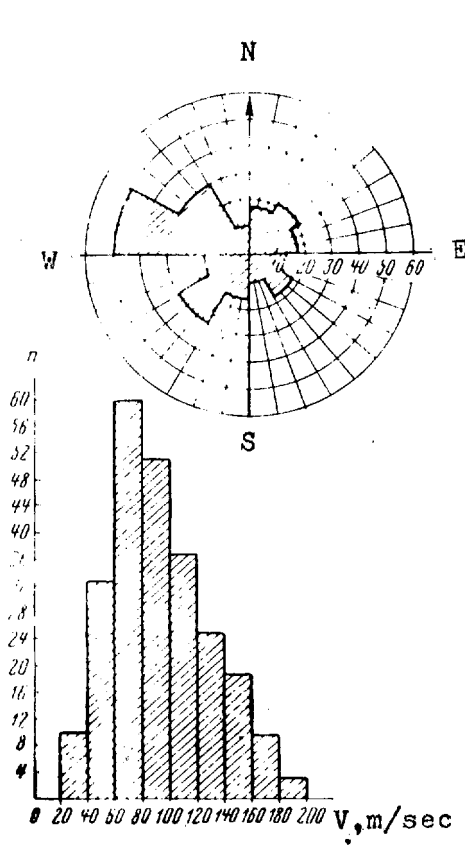

Fig. 2. Histograms of the magnitude of the velocity and direction of drift in the F2 layer for the period from April 1958 through October 1959.
n-the number of cases

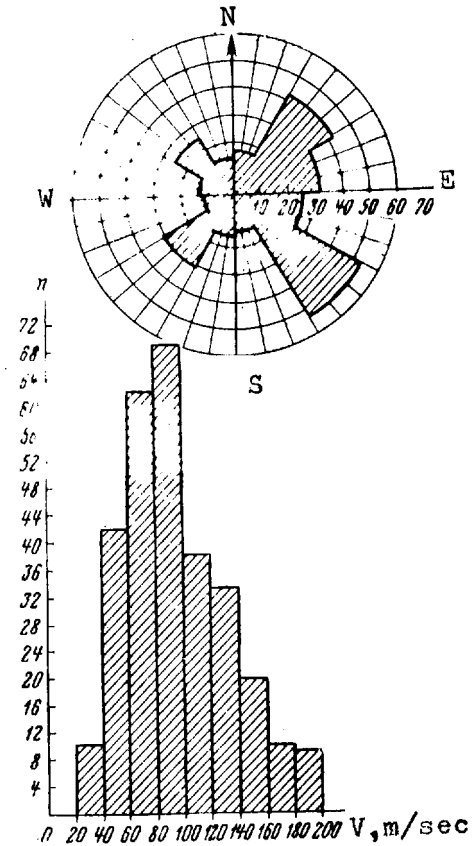

Fig. 3. Histograms of the magnitude of the velocity and direction of drift in the E layer for the period from April 1958 through October 1959.
n-the number of cases

Fig. 3 gives corresponding histograms for the E layer. As for the F2 layer, the drift velocity magnitude in the E region lies within the same interval 20-200 m/sec. However, the most probable values of the velocity are 80-100 m/sec. In this case, the drift direction is primarily eastward (30-60 and 120-150°).

To establish the seasonal relationship of the drift of the small scale irregularities, histograms were compiled of the magnitudes of the velocity and direction of the movement for each month, which were then entered on the seasonal histograms. Figure 4 gives the seasonal histograms for the F2 layer while figure five is for the E layer. Table 1

Approved For Release 2001/03/26 : CIA-RDP96-00787R000500130079-9
 THE DRIFT OF SMALL-SCALE IRREGULARITIES IN THE IONOSPHERE (CONT'D)

gives the seasonal variation of the most probable values of the velocity and direction of the drift. It is evident from figure 4 and table 1 that for the F2 layer, the drift velocity during autumn and winter reaches most probable values of the order of 100 m/sec which is somewhat higher than during summer and spring.

Season	Most probable velocity m/sec		Most probable direction degrees	
	F2 layer	E layer	F2 layer	E layer
Spring	60-80	60-80	NW (270-300) NE (30-60)	SE (120-150)
Summer	60-80	80-100	SE (120-150)	SE (120-150)
Autumn	60-100	80-100	NW (270-300) NW (270-300) SW (210-240)	NW (270-300)
Winter	60-100	100-140	NW (270-300) SW (210-240)	SW (210-240)

The drift direction in all seasons was, for the most part, NW (270-300°) but it was SW (210-240°) during spring and autumn.

For the E layer, the drift velocity during winter is higher than during summer and reaches a most probable value close to 140 m/sec. During spring and summer the drift direction is eastward, while during autumn and winter it is westward.

We were able to compare our data with the results of investigations of drifts of the small scale irregularities made at other Soviet Union stations [3]. Table 2 gives a comparison of the results of the observations for the F2 layer. Table 2 shows the more frequently encountered values of the magnitude and direction of the drift velocity for different seasons and for the entire observational period. The comparison shows that the velocity value by seasons is in good agreement for all the examined stations. During the spring there is an increased scatter of directions for all the stations, but the westerly direction (with slight deviations to the north and south) is general. A westerly

Approved For Release 2001/03/26 : CIA-RDP96-00787R000500130079-9

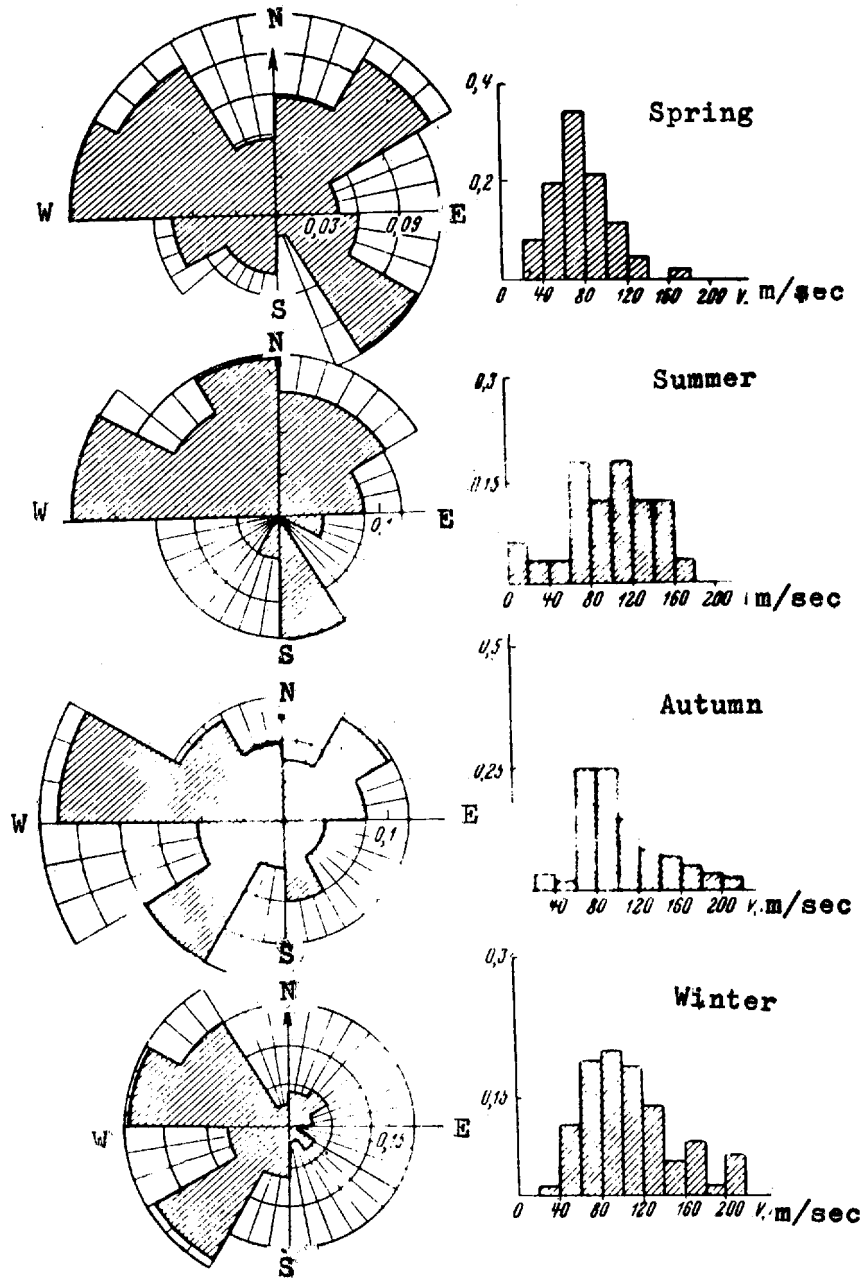

Fig. 4. Histograms of the magnitude of the velocity and direction of drift in the F2 layer for different times of the year. The relative number of cases $n_i / \sum n_i$ are plotted on the y-axis and along the radii.

T-RC-21

CIA No. 9678780

PAGES 7 & 8 OF 11 Pages

THE DRIFT OF SMALL-SCALE IRREGULARITIES IN THE IONOSPHERE (CONT'D)

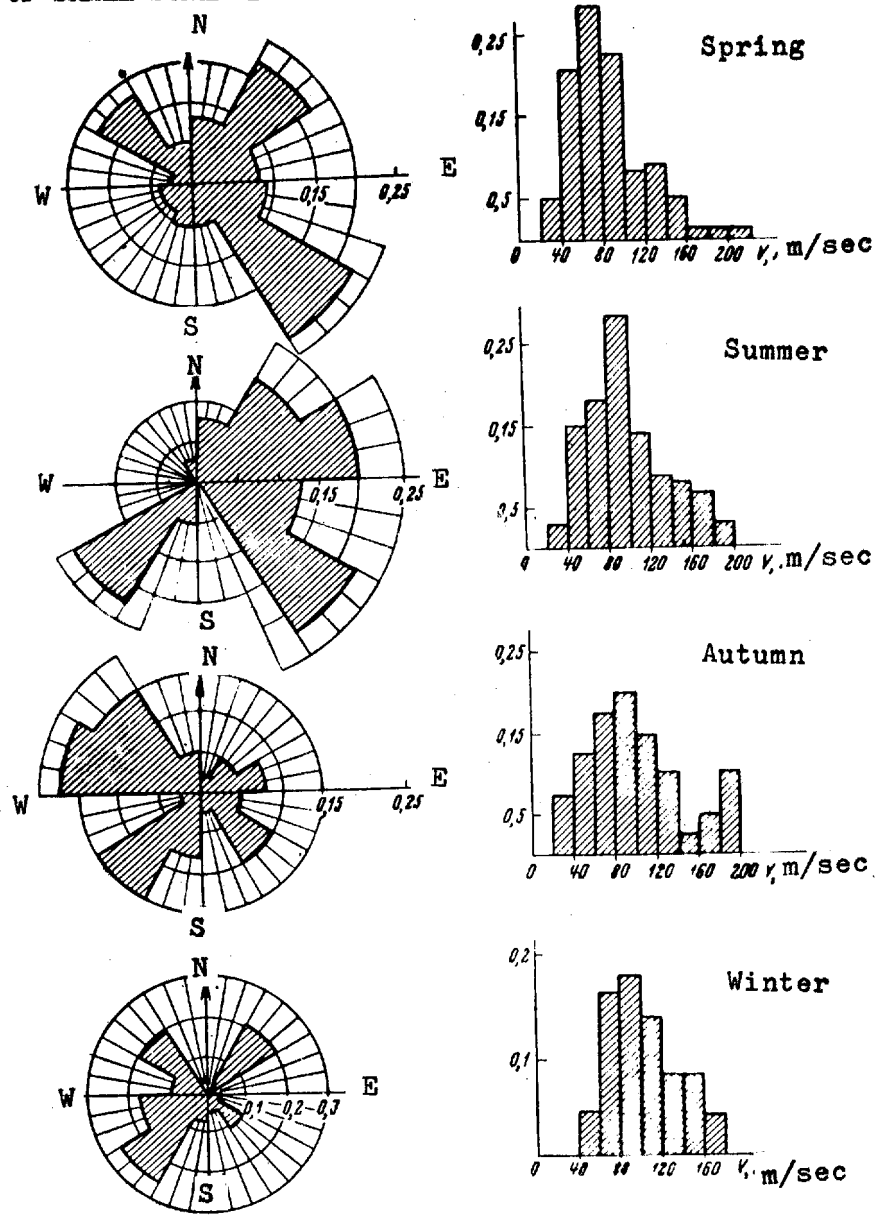

Fig. 5. Histograms of the magnitude of the velocity and direction of drifts in the E layer for different times of the year. The relative number of cases $n_i / \sum n_i$ are plotted on the y-axes and along the radii.

direction prevails during summer. During autumn, a westerly direction (210-240 and 270-300°) prevails for Irkutsk, then, on the other hand, an easterly drift direction is noted for Moscow and Tomsk along with the westerly direction. During winter, the direction is also westerly for all stations.

A comparison of the data for the E layer for Irkutsk, Kharkov and Tomsk with the data given in table 3 shows that the magnitude of the most probable velocity for all three stations lies within the interval 40-100 m/sec, while the general direction is NW. At the same time, the drift direction, compared with number of appearances with the NE direction is SW in Kharkov and Tomsk. A SW direction is seldom observed in Irkutsk. Here the additional direction is SE. In our opinion, such a divergence is explained by the number of observations in the E layer at Irkutsk as compared with the data examined^[3] of other stations, which makes it possible to distinguish the most probable directions of the movement in the E layer with great accuracy.

4. CONCLUSIONS

The observations of the drifts of the small scale irregularities in the ionosphere over Irkutsk have indicated that regular drift with a velocity of 60-80 m/sec in a principal westerly direction takes place in the F2 layer. The drift velocity has a sharply defined seasonal variation. The observations verified the presence of the drift of the small scale irregularities in the E layer with a velocity of 80-100 m/sec in a principal EW direction. The drift velocity for the E layer also has a sharply defined seasonal variation.

The comparison of the obtained data with the data of other investigations verifies the presence of a common circulation system in the ionosphere. At the same time, the drift of the small scale irregularities is also characterized by local peculiarities (additional directions, daily variation, etc).

THE DRIFT OF SMALL-SCALE IRREGULARITIES IN THE IONOSPHERE (CONT'D)

TABLE 2

Season	Irkutsk April 58-Oct. 59		Moscow Jan 56-Dec 58		Ashkhabad Jan-Jun 58		Tomsk Sept 57-May 58	
	V, m/sec	φ degrees	V, m/sec	φ degrees	V, m/sec	φ degrees	V, m/sec	φ degrees
Spring	60-80	NE (30-60) SE (120-150) NW 270-300	40-60	SE (100) NW (280)	65	SE (120-130) SW (210-240)	40-60	SW NW
Summer	60-80	NW 270-300	60-80	NW (280)	70	SW 210-240	--	--
Autumn	60-100	NW 270-300 SW (210-240)	60-80	SE (100) NW (280)	--	--	70-100	SW NW NE NW
Winter	60-100	NW 270-300 SW (210-240)	60-100	SE (100) NW (280)	65	SW (220-230)	80-100	SW NW SW
Entire period	60-80	NW 270-300	80	W 280	58	SW	40-60	SW

- 126 -

TABLE 3

<u>Observational Station</u>	<u>V, m/sec</u>	<u>Direction</u>
Irkutsk	60-100	NE and SE
Kharkov	40-60	NE, SW (during the day) and SW (night)
Tomsk	60-80	NE and SW

T-RC-21

CIA No 9678780

PAGE 11 OF 11 PAGES

THE DRIFT OF SMALL-SCALE IRREGULARITIES IN THE IONOSPHERE (CONT'D)

- 127 -

LITERATURE

1. Beynon, W. J. G. and G. W. Brown, (Ed.) The measurement of ionospheric drift, Manual, Vol. III, No. 5, 1956, London Pergamon Press, 1957.
2. Grishkevich, L. V., Iu. V. Kushnerevskii and N. A. Mitiakov. "Izmereniia dreifa v ionosfere (dopolneniia i rekomendatsii)" (Measurements of drift in the ionosphere (Supplements and recommendations) Nauchnyi Institut Zemnogo Magnetizma i Rasprostraneniia Radiovoln Akademii Nauk SSSR, (manuscript) 1957.
3. Dreify i neodnorodnosti v ionosfere (Drifts and irregularities in the ionosphere), Izdatel'stvo Akademii Nauk SSSR, Seriya MGG, No. 1, 1959.
4. Kokourov, V. D. "Apparatura dlia izmereniia vetrov v ionosfere" (Apparatus for the measurement of winds in the ionosphere), Tomsk, Doklad na Vsesoiuznom mezhvuzovskom soveshanii po radiofizicheskim metodam issledovaniia ionosfery, 1956.

FIRM NO. <i>2216</i>			CLASSIFICATION UNCLASSIFIED			PROCESSING DATE <i>DEC 1962</i>		
Approved For Release 2001/03/26 : CIA-RDP96-00787R000500130079-9 FBG								
CODE	COUNTRY		PS	AF CHART	ACTIVITY CODES			
<i>491</i>	<i>USSR</i>		<i>1131</i>		<i>438</i>			
LOCATION <i>Orkutsk</i>			S/T	NAME OF INSTALLATION <i>Magnetic Ionosphere Sta.</i>				PL. NO.
DATE/INFO			DATE/SOURCE			PF		
DA	MO	YR	DA	MO	YR			
-	-	-	-	-	<i>62</i>			
CONTROL NO. <i>9678780</i>			SOURCE <i>T-RC-21 # 36</i>			EVAL		

DOC ATTACHED

OVER

Approved For Release 2001/03/26 : CIA-RDP96-00787R000500130079-9