

~~SECRET~~

NOT RELEASABLE TO FOREIGN NATIONALS

ORCON

INSCOM

GRILL FLAME

PROGRAM

SESSION REPORT

**GRILL FLAME**

CLASSIFIED BY: MSG, DAMI-ISH  
051630Z JUL 78

REVIEW ON *June 2000*

*Copy 1 of 3 copies*

~~SECRET~~

~~SECRET~~

SUMMARY ANALYSIS

REMOTE VIEWING (RV) SESSION CD-23

1. (S) This report documents a remote viewing session conducted in compliance with a request for information on a target of interest to USI.
2. (S) The remote viewer's impressions of the target are provided as raw intelligence data, and as such, have not been subjected to any intermediate analysis, evaluation or collation. Interpretation and use of the information provided is the responsibility of the requestor.
3. (S) The protocol used for this session is detailed in the document, GRILL FLAME Protocol, AMSAA Applied Remote Viewing Protocol (S), undated.
4. (S) Following is a transcript of the viewer's impressions during the remote viewing session. At TAB A are drawings made by the remote viewer reference his impressions of the target site. At TAB B is target cuing information provided the remote viewer.

~~SECRET~~

~~SECRET~~

TRANSCRIPT

REMOTE VIEWING (RV) SESSION CD-23

TIME

#66: This will be a remote viewing session for 1400 hours, 27 May 1980.

PAUSE

Relax and concentrate now. Relax and focus your attention on target 8017. Relax and concentrate. Focus on 8017, and, describe the target to me.

PAUSE

+08 #24.5: Banks of.....see banks and banks of equipment like with fixed chairs in front...steel chairs, table...and big electronic boards..all electronic boards, and unit stacked ...gray, gray metal...little place. It's like real tight. Very cramped.

#66: Tell me what makes you say cramped. Tell me about that.

#24.5: It's like..uh...kind of (mumbling)...uh...not much elbow room...feeling like I'm in a.....like I'm in a little control room...something. The board's almost slope back over this chair, and I almost had a feeling that I was almost like you could see bare rock, like bare rock visible at the end of this little room...rear rock wall... bare rock wall like.

#66: Sit in one of the chairs for a moment and tell me what goes on where you sit.

PAUSE

#24.5: I ...uh...I feel...looking at it...equipment and displayed panels ...lights...see lights, looking switches....communicating, talking, aboarding, status of things, equipment checked out, all okay, type of monitoring of this equipment which pertains to something bigger elsewhere. I feel like headsets, but not listening so much as reporting.

#66; And, look at the other seats. Look to your left at the other seats. Is there anything different about any of the other seats than your particular seat?

PAUSE

~~SECRET~~

~~SECRET~~

+13 24.5: Look funny. They.....not like mine. They're like a barber chair. Feeling like a barber chair. This feeling of seat adjustment, padding, almost a head rest, lean back...they slide back into almost a prone, vertical, I mean horizontal...they adjust, but they are separately adjusted. They are connected but they are separate. I feel they are connected. It's like almost a bench... like a bench but it has separately adjustable segments, and this is all faced...uh...on like...I get this gray industrial gray, short board...almost a lap board at the base of the equipment, and like the feet, my feet could go way back and in under the board, if I chose so.... being my ...slide my chair, slumping in under it I would scoop down in under it, and I could look up the board... I could look farther up the board, and the board is segmented over me. The board leans over me so that I could look up at it.....

PAUSE

I seem to be three.....oh! this..... place is .....very reminiscent of a steel and green and gray. The room almost appears round at one point, behind the chairs, like the wall curved around in the far side, and that's.....I swear I'm on the ground. Like I can look through the wall at the far end, and I have the feeling that I see bare rock, but the room is finished but I get this bare rock wall feeling, like on the other part of this....on the other side of the finishing part, and the room is....round, like a it's convoluted. It's got some sort of little, little jets here and jets there...floor plan appears very irregular.

#66: Okay. Now, I want to stay in these places where these seats are. If you stand up behind one of the seats, and put your hands over your head can you touch the top?

#24.5: I can just.....barely...not reach it.

#66: How about sideways...extending your arms out sideways?

+17 #24.5: If I...extending to the...thinking I'm behind the middle seat, extending to the right, I cannot reach the protrusion that comes out to the right of the right seat. That's maybe another 3 feet to the left. If I am extending my hand I cannot reach the edge there. It also feels farther beyond me. But, there is no protrusion on that side. The...there are pipes, but the bank of equipment ends. Back around the equipment then there are other things but they're not looking at things...they are working at things there...feeling of like valves, and pipes, and ummm, different than the equipment bank though.

~~SECRET~~

~~SECRET~~

#66: Okay. Now, facing in the direction of the seats, facing the direction the way the seats face, I want you to move to the other side of the seats, and then face back at the chair so you can see the back of the chair where you would sit down, and move slowly backwards through the wall of this area where you've been and describe it from the outside.

PAUSE

+20 #24.5: Oh.....Let me relax a minute and try that again.

PAUSE

Have a.....capsule type shape...the first time I did it I...uh...it was rather spontaneous...what I...felt that I passed through the skin of a craft of some kind and was going to be left behind, and it frightened me. I had the rapid vanishing of what it was I had been in.... against blackness, as though I had been in a exited capsule ...it had just kept excellerating from me, but it sort of surprised me and I lost what I was doing. It was as though this thing was disappearing into the blackness. I went back inside in an attempt to try again. Still end up with a essentially capsulated...working area. A cylindrical room, fully metallic almost with a.....I don't know. I keep having a strong association, somehow, with a missile or a rocket as though I was...it's something vertical on my right that I keep wanting to see, and I don't see it.

#66: All right. Now, just relax and concentrate for a moment. I feel this time you are ready for some additional information. Relax and concentrate now. I have suspected for some time from your descriptions that you were inside an aircraft of some type. Our targeting today for 8017 involves aircraft. It is now your job to describe this aircraft to me.

PAUSE

+26 #24.5: Okay. I'm going to have to wait here a little bit. Try and figure all that out.

PAUSE

#66: Stick with the imagery that you have, that appears valid.

#24.5: Yes. I will. I'm just trying to go deeper, again.

#66: That's fine. We have plenty of time. I will wait.

~~SECRET~~

~~SECRET~~

+30

24.5: I...uh.....I...uh...get a pretty good image of a...the one that's got little bumps on the end of each wing, and the wings are swept back. Like a Bear or a Bison. The one that's got a in the wing engines, bumps in there, the fuselage, two side by on each side in a swept tail of the ...the knob way up on the top, but, above half way near the top of the tail. I'm getting a round, round nose..... bubble type nose.....bumpy, stubby, stubby nose. Not a, not a big jet or.....not really streamlined. The wings are almost abnormally long for the diameter of the fuselage. Seems to be a, a bump in the back of the tail. The wings droop. Definite feeling like a drooping eagle. The wings drooping down.

#66: Okay. Is this plane in a flight or on the ground?

#24.5: Well, I'm seeing it at various positions. Various modes.

PAUSE

#66: This the same aircraft you feel you were with before?

#24.5: Yes. It...I... Yes.

#66: Do you recognize this aircraft?

+35

#24.5: It's...uh...it's one of the, one of the Russian kind. Like I said a Bear or Bison. Whichever one it is that has the, the two engines on each wing, close in, built in the wing, was my feeling. The air scoop intakes are actually the beating edge of the wing, is what I feel like. Though, when I fell out of the thing before I had ..it was disappearing into the darkness it had a peculiar contour to it which had angulars and dangling things. Now I understand why it had those. Because of the angle which I exited. I was seeing wings and tail all at the same time. So this fits. It fits. I think it fits. I think it's the same one.

#66: All right. I want you to locate now where this aircraft is on the ground or aircraft similar to it, on the ground.

PAUSE

As it moves to the ground in your mind, tell me if there's anything that you notice different about it as it sits on the ground, as it comes to the ground.

PAUSE

~~SECRET~~

~~SECRET~~

- +39 #24.5: I have a.....when you asked me to locate the aircraft I had a feeling of it being in a place near Manchuria, but somewhere north of that...like staged, staging base, or staging location, north of Manchuria, but along the inside the Siberian border. Uh...flat, plainey, dust... uh, not dust, a flat plains area...wide open expanses. With some small rollingness to it, but in the horizon huge mountains way on the horizon that could be seen then to the south. Some sort of a staging idea, or field. Staging field. And, as I worked along the...looking at the plain area with the mountains the word ALMA ATA came into my mind, and I...ALMA ATA...don't know what else.....
- PAUSE
- #66: Is this plane alone or is it with the other planes?
- #24.5 Oh, there are others. I see...just looking to my right, I had a feeling of some sort of fighter located there. Something smaller than the one ...some sort of protective glass, wall area with the fighter and the feeling these, there are more of these around, and there are other planes here. There are many, many more planes here. It's an act of functional base.
- #66: Okay. Move your perceptions now, past the staging concept. Where are these going?
- #24.5: Ahhh.....I keep getting this map of the Pacific and a dotted line along the Soviet, Chinese border and Mongolia and it sort of comes down around the border. I see sort of two, two lines like...these aircraft fly (mumbling) uh, comment, reconnaissance type of a situation. I see one line goes up, swings north, Pacific come jack up north to the Aleutians, and I see another line like a possible route that wings down around Korea on the right side of Korea, like listening there, but I get them flying alone. I don't see any massive fleet movement, or anything like that. It's like out of this place they go east and they also go west. They go west along the Chinese border, towards where India would be, I guess. Towards India in back of Japan and everything. I was even flying along the...with maybe one or two fighters for escort along the Chinese border sort of as a precaution, but I see the ones flying east without fighter escort because it's not that necessary. But, I get the feeling alot of water flying over the water...I'd listen to the fleets.....reconnaissance...I don't get any real offensive action.
- +44
- #66: I have no further questions about this target. If there is anything you would like to add, please do so now?

~~SECRET~~

~~SECRET~~

#24.5: No.

#66: All right. Fine. Let's prepare to draw then.

I'm going to go ahead and turn this tape over now, because it is just about ready to run out.

PAUSE

#24.5: Okay. Where to start. Ha.....

#66: I think the first thing you said was something about being in an area that was cramped... It had some chairs or some equipment of some kind.

#24.5: Yeah. That's what I was thinking about starting. Well, before that though, I had, for whatever it's worth, I had some sort of a feeling of a, like proceeding along a segment of tunnel or some sort of thing. I don't know what it was. It was like I was moving along a, some sort of a small, narrow tunnel thing, and then I would pass, like I would pass things, you know. They'd go by me, that were on the walls of this tunnel. It was like segmentations, like things protruding at a certain point. You know. Like, I don't know, maybe bulk heads or compartments or something like that, you know. Anyway, I had that type of a feeling.

Then, then I had this feeling of like bench seats, but separately, that were facing equipment, okay, and...uh.. this feeling was...I'll draw a side view on sketch 1, was as though there was...I described it like a barber chair, ha, okay...barber chair. And, facing this equipment, like this, sketch 1. That feeling. Now, in those, you know, curviness...around on the sides, and tight.. uh..feeling of...I'll do an overhead here, but this is tight feeling. Like maybe only 5 feet, type of a feeling. Very plain, gray, and...gray and greens and sterile. A lot of metal feeling, metal. Almost like it was a metal room, I guess, okay. Sloped, metal room, okay. That's in sketch 1.

An overview of that in sketch 1, is this sort of a feeling. That there are.....feeling was that there were 3....of these..... This is an overview of the seats. And, like each one of these 3 seats would, you know...it's cushioned, padded, type seats,. Short table, like a writing space or desk. Okay. It's somewhat segmented. And there's equipment and dots and dashes and pretty lights and all this stuff all on this equipment board facing these 3 seats. And, the

<sup>6</sup>  
~~SECRET~~



~~SECRET~~

seats were such, that they could be sort of dropped at random. Like the guy in the middle could put his seat back, but the guy on the side might still sit up straight. You know. It was like different, different arrangements like that. Some sort of a thing that protrudes up here. And, here there is just ...on the left side of the equipment rack, there's this pipes and stuff, and, like I said valves, and things like that, to the left. Valves. V-a-l-v-e-s pipes. More mechanical than electronic. It's a mechanical area, whereas this board is an electronic monitoring area, okay. Where they're checking systems and doing this, that, and the other thing.

All right. and the, here is a little bit on the top of the board is my meager attempt at portraying this... canting out of the board over the top of the seats. Then, there's peculiar things, like this that go on, and I felt that this is a passageway there, and this is some sort of, I have no idea, I drew on a couple of them here on the left side, just something that makes the, the roundness get, has squares in it, like risers, or support beams, or something like.

All right. Then, where was I?

#66: Okay. This time I asked you to face ..uh..go around the other side of the seats, and face back of the seats, then move out through the wall backwards, so that you could see from the outside this area that you were in.

#24.5: Hmmm. Well, before that though, I had this feeling that I could, was looking through this. I had this feeling that there was something there, and then there wasn't something there. It was as though I was looking through it. There, but not there. Could look through. These are, okay. Okay, now when I put myself in the center of the back here, like this, is when I saw that the board not only went up, but that it slanted up over the seats. So that people could lean back, and they'd slide..... like a barber chair, when you adjust the barber chair for a shave, you know. Shaving or a hot pad, or something like that. And, they could look up like this, and then they can slide it back up front. This is individual activity.

The view that I got, and if I can remember this, the view that I got when I stepped out of this thing was a definite rush, as though this thing had left me behind and it was flying into the darkness, okay, and moving into black void. Like I had just gotten off an express train, and

~~SECRET~~

~~SECRET~~

it sort of startled me. And, the view I got was a canted left side view which was real funny. It didn't look like a...you know...a...it was weird, is what it looked like.

#66: Draw it just the way you saw it.

#24.5: Okay. Going that way in sketch 3. Droopiness is on each side, but something rising up in the back, on the back right, as though that's like a, a, some bigger part or in the foreground so it looks bigger, but then the droopiness on the right and the left, and then the, you know, I didn't know what the hell it was when I stepped out of it. It looked like I was stepping out of a satellite or something, okay, and it was....you know. I had the definite feeling like I was stepping into space, and the black dots are actually white dots, you know, against the darkness. pshaw...took off. It was just leaving me behind in a rush, okay. Phew...then ...uh...this is a, let me draw this, this is a left rear perspective.....disappearing. All right. Then, what happened?

#66: Then I provided you with the information that we were, in fact, working an aircraft type target, and I wanted you to focus on that aircraft and describe it to me.

#24.5: Okay. The...uh...I'm not any good at aircraft..... The definite feeling that I had was of a ..... a Bison or a Bear. The one that's got the two engines in close to the fuselage with some sort of a funny thing on it, okay. Uh...and I had a nose thing on it too. It looked as though the nose was opened. And, this was plexiglass there. Uh...that's what it was. It was that type of an aircraft. Okay. And...uh...the wings are swept back....I'll draw an overhead view, the wings are swept back, but they're not delta..... That looks like it's slumped forward, that's wrong. I should have drawn it differently. I'll draw another one here, Damn it! .....

That's what I wanted to do. It's that type. Like that. That.....oh, wait a minute...in the forward leading edges.....had the...engines were built right into it... forward leading edges moved back, but the rear trailing edges also moved forward. So it's almost triangular in shape, okay. That's 5. That's what I'm trying to describe. Like that. Okay. With 2 engines in close to the fuselage on each wing. All right. Uh, what next?

~~SECRET~~

~~SECRET~~

Six. I imagined this thing in flight and on the ground. I imagined it landing, is what I was doing. I watched it land, type of a situation. And, I don't know what it was. I had some sort of a feeling that, that bird, the one I was watching, dropped something, like it was testing something and dropped something. I had just a flickering feeling, I didn't even talk about it on the tape. I had a flickering feeling that it dropped something that looked like a long cylinder, and that was it. Okay. I have no idea how to even go about describing it. Let me use this as a tracer. So, for six.....

Okay. Four, five. I had the feeling of something long... dropping down out of the...long and cigar shaped..... and that was the only thing I had. And, I don't know what gave me that. I didn't even see the back end of it. You know. I didn't see...it's just some sort of silver, metallic thing falling down out of it. Maybe flying by itself; maybe not flying by itself; maybe just falling down. Okay. All right. Long cigar dropping from beneath. All right. That was that. But, then I got this definite feeling that it landed in some place that was flat prairie and there were mountains on the horizon and that it was somewhere north of Mongolia. Mongolia was what I keyed on. This blotch in the mountains was this country called Mongolia. But, somewhere north of this across the border in Russia was where this thing landed. Okay. And,..... sort of a feeling of a map, okay...someplace like in here.

Now, then I got a flavor of recon.....after I was on the ground and looking at....there were other aircraft around... I got this feeling, well, okay, what is thing here. It's sort of like some advanced base or something like that. But, what are they doing here? I couldn't figure out what they were doing. The word Alma Ata also occurred at this time.

#66: And, what does that mean to you?

#24.5: I didn't know at the time. Alma Ata, and then afterwards thinking about Alma Ata, I think Alma Ata has something to do with missile tests. I think it's some sort of missile test range, but I'm not sure. But, then I had, I'll draw like another map, is important here, Mongolia, Mongolia, okay, and had this feeling of this border which comes down around like this, and I had the feeling of what I was looking at was Korea. Like this type of a thing. But, anyway, it was this type of an idea. And, that these.....I had the feeling of traveling back and forth. Like airplanes would go this way up to what

~~SECRET~~

~~SECRET~~

would be, what would be that, that would be west, planes, planes flying west, have fighter escort..... Then I had this feeling, the dotted line with arrows, was, two things occurred here, I'll darken this thing in here .....this is UR, PRC, was that two things occurred... like they would go out this way.....or they would go out this way, and fly up towards the Aleutians along the coast of the Soviet Union. Okay. Planes flying west have fighter escort; planes, and I'll call them reconnaissance, because that was what I said.....have no, no feeling of fighter escort, have no fighter escort. Okay, planes fly over ocean.....along Korea over ocean. In here planes fly along coast to Aleutians. And, they're like recon flights and that's it.

#66: Okay.

#23.5: What's that? That's eight. So, that's all I can think of saying. I just don't have any feel at all for...8, 7, 6, okay.

#66: Okay. Fine.

~~SECRET~~

**TAB**

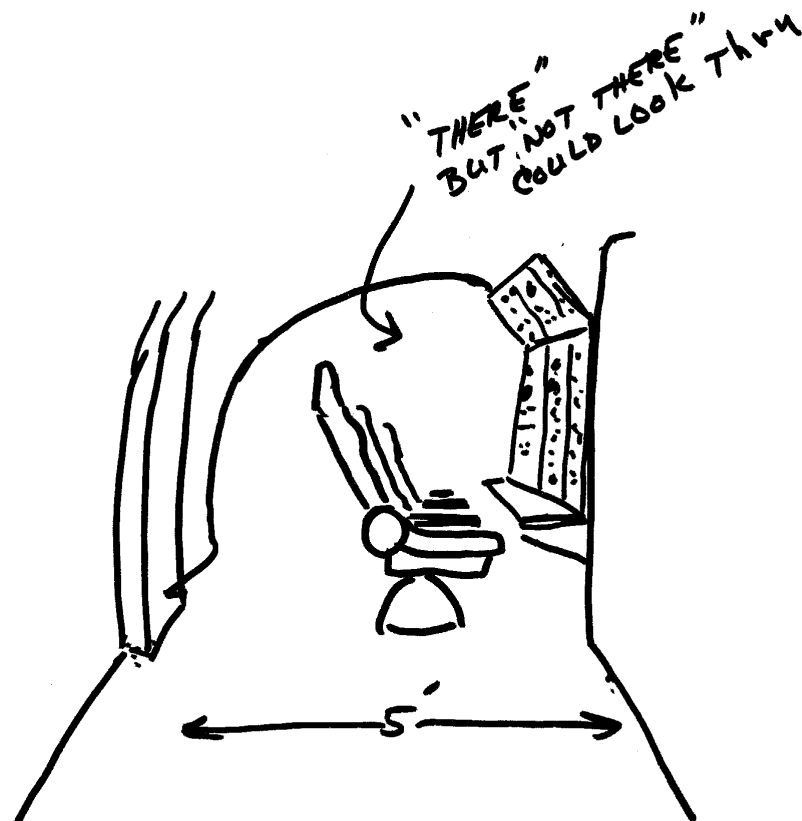

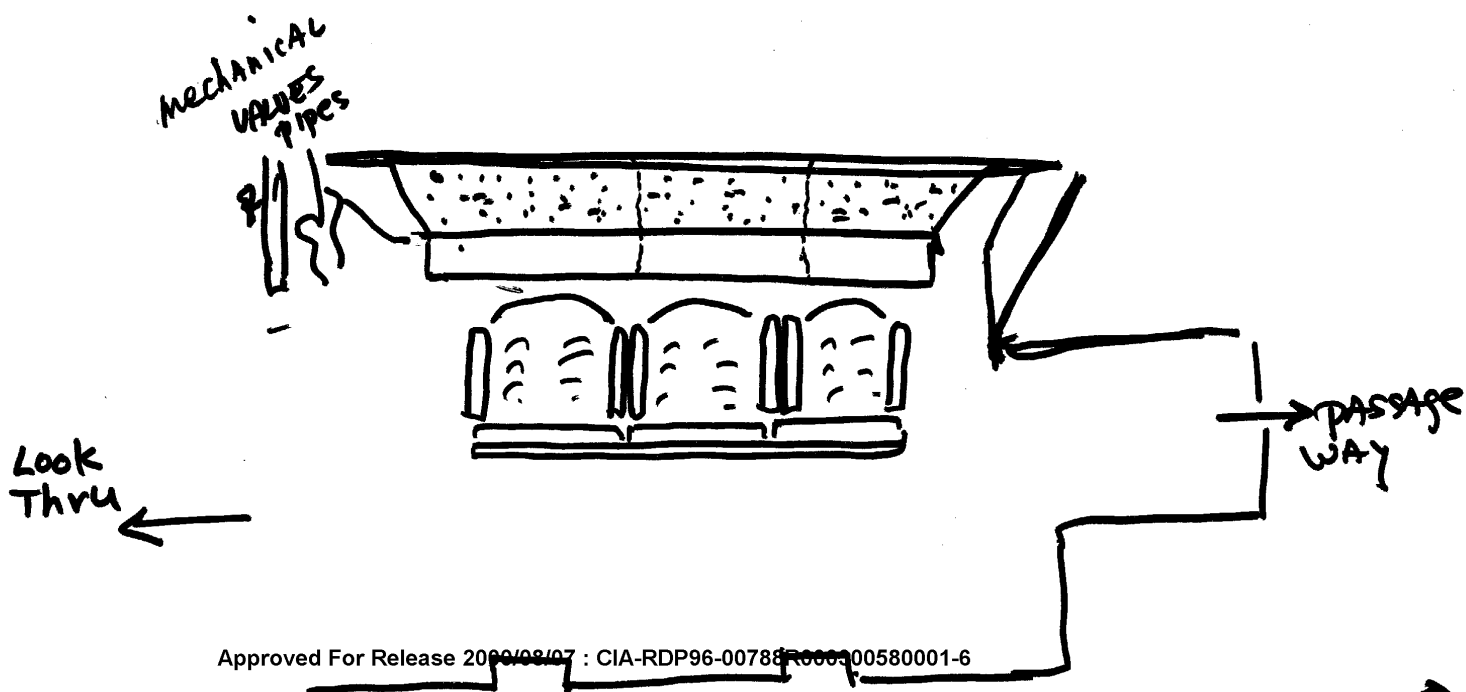

Approved For Release 2000/08/07 : CIA-RDP96-00788R000300580001-6



L. REAR  
perspective  
disappearing  
to L. AWAY

Approved For Release 2000/08/07 : CIA-RDP96-00788R000300580001-6



Approved For Release 2000/08/07 : CIA-RDP96-00788R000300580001-6

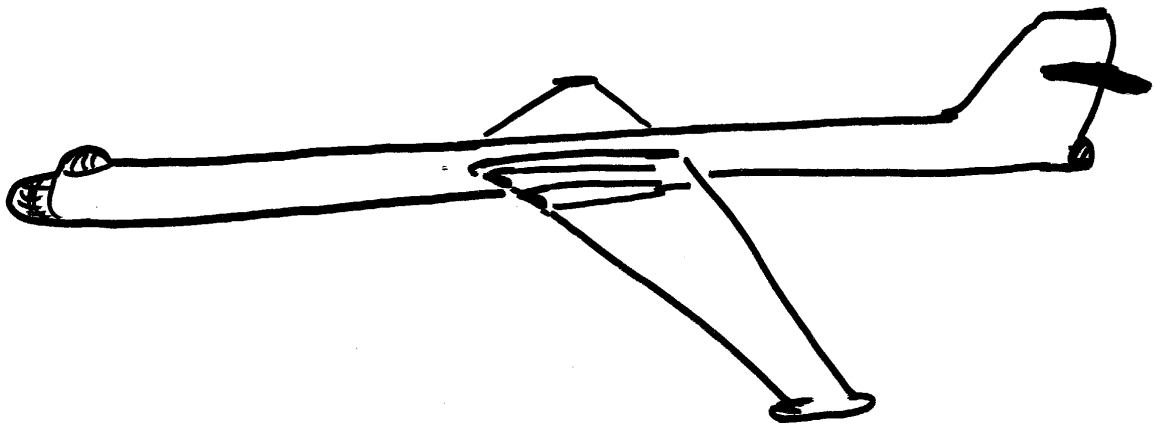

Approved For Release 2000/08/07 : CIA-RDP96-00788R000300580001-6



Approved For Release 2000/08/07 : CIA-RDP96-00788R000300580001-6

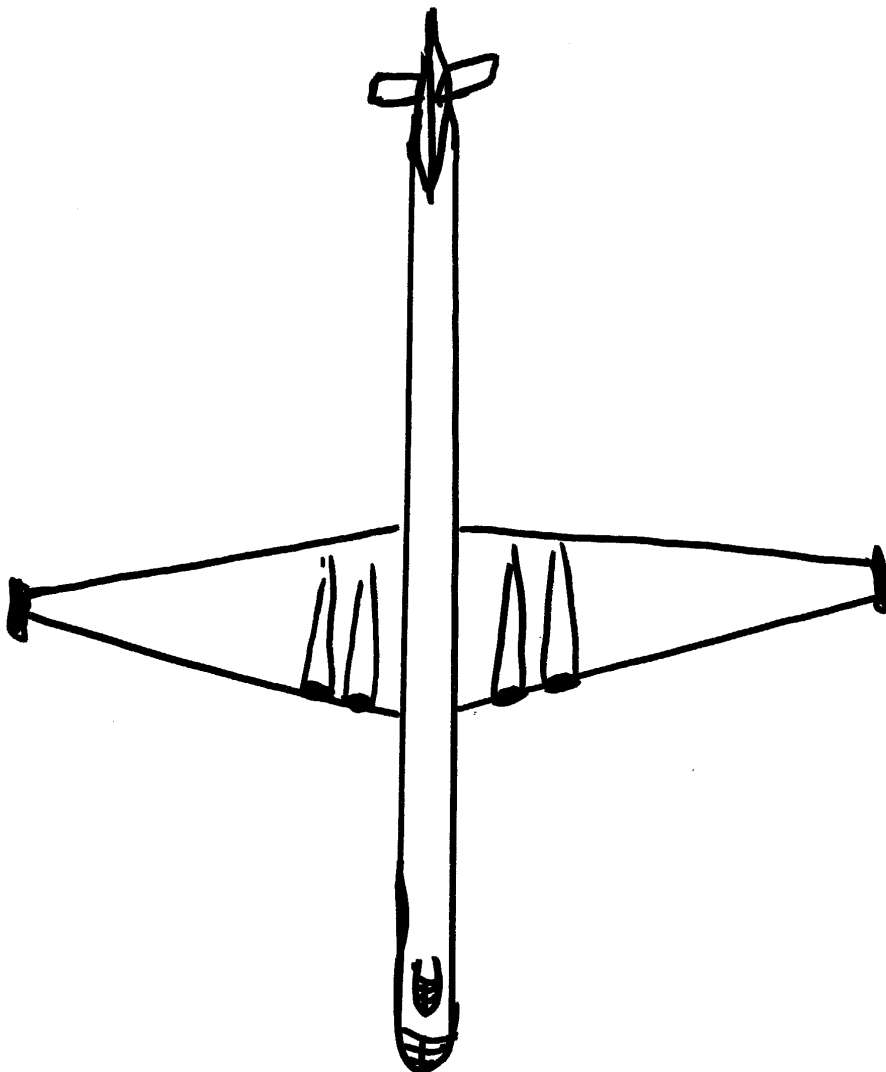

Approved For Release 2000/08/07 : CIA-RDP96-00788R000300580001-6

Approved For Release 2000/08/07 : CIA-RDP96-00788R000300580001-6

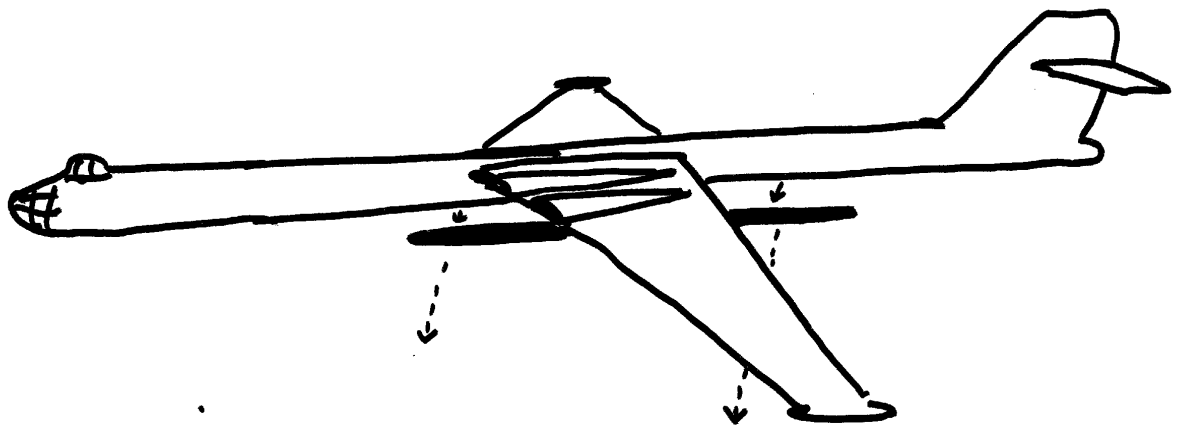

long cigar  
droppings from  
beneath

Approved For Release 2000/08/07 : CIA-RDP96-00788R000300580001-6

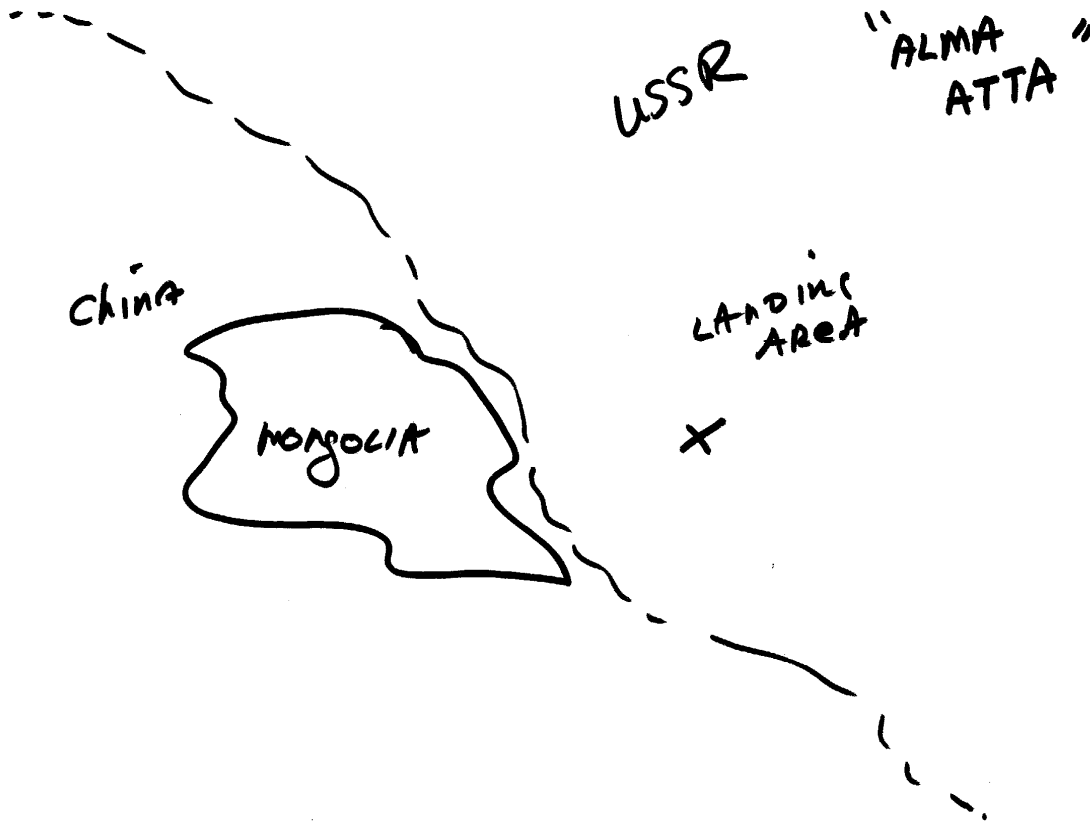

SG1A

Approved For Release 2000/08/07 : CIA-RDP96-00788R000300580001-6

Approved For Release 2000/08/07 : CIA-RDP96-00788R000300580001-6

**TAB**

~~SECRET~~

TARGET CUIING INFORMATION

REMOTE VIEWING (RV) SESSION CD-23

1. (S) Prior to the session the remote viewer was told only to focus on the target designated by 8017.

SG1A

2. (S) The interviewer knew the mission involved [REDACTED]  
[REDACTED]

SG1A

~~SECRET~~